

INSTALLATION

OPERATION

MAINTENANCE

MELLTRONICS DRIVES
FOCUS 2
SINGLE PHASE CONTROL
FOR DC MOTORS
1/4 TO 5 HP

Made in the USA by:



MAIL: PO BOX 2368
INDIAN TRAIL, NC 28079-2368
SHIPPING: 3479 GRIBBLE ROAD
MATTHEWS, NC 28104-8114

PHONE: 704-821-6651
www.melltronics.com

SAFETY WARNINGS

Improper installation or operation of this drive control may cause serious injury to personnel or equipment. Before you begin installation or operation of this equipment you should thoroughly read this instruction manual and any supplementary operating instructions provided. The drive must be installed and grounded in accordance with local and national electrical codes. To reduce potential of electric shock, disconnect all power sources before initiating any maintenance or repairs. Keep fingers and foreign objects away from ventilation and other openings. Keep air passages clear. Potentially lethal voltages exist within the control unit and connections. Use extreme caution during installation and start-up.

BRANCH CIRCUIT PROTECTION

Branch circuit protection is to be provided by end user.

OVERLOAD PROTECTION

Overload protection must be provided per national electric code article 430, Section C.

INITIAL CHECKS

Before installing the drive control, check the unit for physical damage sustained during shipment. Remove all shipping restraints and padding. Shortage or damage should be reported promptly to CARRIER and your distributor.

INSTALLATION LOCATION OF CONTROL

Controls are suitable for most factory areas where industrial equipment is installed. The control and operator's control station should be installed in a well-ventilated area. Locations subject to steam vapors or excessive moisture, oil vapors, flammable or combustible vapors, chemical fumes, corrosive gases or liquids, excessive dirt, dust or lint should be avoided unless an appropriate enclosure has been supplied or a clean air supply is provided to the enclosure. The location should be dry and the ambient temperature should not exceed 104°F. If the mounting location is subject to vibration, the enclosure should be shock-mounted.

If the enclosure has a ventilating fan, avoid, wherever possible, an environment having a high foreign-matter content otherwise the filters will have to be changed more frequently or micron-filters installed. Should a control enclosure require cleaning on the inside, a low pressure vacuum cleaner is recommended, not an air hose, because of the possible oil vapor in the compressed air and its high pressure.

USING THIS INSTRUCTION BOOKLET

Whenever equipment modifications are not involved, the information contained in this instruction booklet describes drive system setup and operating procedures of most drive applications. This manual should be provide to end user as it also provides the information required by the customer to install and maintain the equipment.

FOCUS DRIVE – RECEIVING AND STORAGE

Please record information below before installing the unit and use these numbers when communicating with the factory.

CUSTOMER

JOB NO.

HORSEPOWER RATING

VOLTAGE

MODIFICATIONS

TABLE OF CONTENTS

SECTION 1 SAFETY 6

 1.1 GENERAL SAFETY PRECAUTIONS 6

 1.2 INSTALLATION SAFETY 6

 1.3 Start-up Safety 7

SECTION 2 GENERAL INFORMATION 8

 2.1 INTRODUCTION 8

 2.2 GENERAL DESCRIPTION 8

 2.3 TYPICAL PACKAGING 8

 2.4 EQUIPMENT IDENTIFICATION 9

SECTION 3 CONTROL SPECIFICATIONS AND FEATURES 10

 3.1 EQUIPMENT RATINGS 10

 3.2 SERVICE CONDITIONS 10

 3.3 PERFORMANCE SPECIFICATIONS 10

 3.4 OPERATOR FUNCTIONS 10

 3.5 POTENTIOMETER ADJUSTMENTS 11

 3.6 CUSTOMER PROGRAMMABLE SELECTIONS (JUMPERS) 11

 3.7 STANDARD FEATURES 11

 3.8 PRE-ENGINEERED MODIFICATION KITS 11

SECTION 4 INSTALLATION 14

 4.1 SAFETY WARNINGS 14

 4.2 INITIAL CHECKS 14

 4.3 CONTROL JUMPER PROGRAMMING 14

 4.4 DETERMINING THE CONTROL LOCATION 19

 4.5 INSTALLING PANEL MOUNT AND LESS OPERATORS CONTROLS 19

 4.6 INSTALLING ENCLOSED CONTROLS 19

 4.7 POWER WIRING 19

 4.8 PANEL MOUNT AND LESS OPERATORS CONTROL LOGIC AND SIGNAL WIRING 21

 4.9 ENCLOSED CONTROL LOGIC AND SIGNAL WIRING 22

 4.10 INSTALLING MODIFICATIONS 22

SECTION 5 OPERATION AND START-UP PROCEDURE 23

 5.1 INTRODUCTION 23

 5.2 START-UP PROCEDURE 23

SECTION 6 FUNCTIONAL DESCRIPTION 26

 6.1 POWER BRIDGE AND FIELD SUPPLY 26

 6.2 RUN/JOG AND START/STOP LOGIC 27

 6.3 ACCEL/DECEL CIRCUIT 27

 6.4 REGULATING CIRCUITRY 27

 6.5 FEEDBACK SCALING 27

 6.6 CURRENT LIMIT CIRCUIT 28

 6.7 FIRING CIRCUITS 28

 6.8 POWER SUPPLIES 28

 6.9 INDICATORS 28

SECTION 7 MAINTENANCE AND TROUBLESHOOTING 30

 7.1 IMPORTANT SAFEGUARDS 30

 7.2 ROUTINE MAINTENANCE 30

 7.3 TROUBLESHOOTING OVERVIEW 30

 7.4 BASIC TROUBLESHOOTING 31

SECTION 8 ORDERING SPARE PARTS 34

SECTION 9 SUPPLEMENTARY TECHNICAL INFORMATION 38

TABLE OF CONTENTS

SECTION 10 BASIC APPLICATION 55

10.1 BASIC MECHANICS 55

10.2 TORQUE VS. HORSEPOWER 55

10.3 MATCHING THE DRIVE TO THE MACHINE 55

10.4 DC DRIVE CHARACTERISTICS 56

10.5 OTHER MECHANICAL CONSIDERATIONS 57

10.6 MOTOR APPLICATION FORMULAS 58

10.7 ELECTRICAL FORMULAS 60

10.8 OTHER USEFUL FORMULAS 60

SECTION 11 WARRANTY 63

LIST OF TABLES

Table 1: Control Rating Table 10

Table 2: Jumper Programming for Speed Regulated Operation 17

Table 3: Jumper Programming for Torque Regulated Operation 18

Table 4: Voltage Check Chart 33

Table 5: Control Standard Connection Scheme Terminal Blocks TB1 and TB2 38

Table 6: Customer Jumper Programming Chart (filled out by customer) 38

Table 7: Density Factors 59

Table 8: Inertia of Steel Shafting (per inch of length) 59

LIST OF FIGURES

Figure 1: Oscilloscope Connections 7

Figure 2: Typical Panel Mount Control Product Nameplate..... 9

Figure 3: Panel Mount Control 9

Figure 4: Control Modification Kits 13

Figure 5: Main PC Board Jumper Locations 15

Figure 6: Connection of Motor Leads to Enclosed, Less Operators, 21

Figure 7: Power Bridge Assembly 26

Figure 8: Power Bridge Assembly 27

Figure 9: Control Circuit Block Diagram..... 29

Figure 10: Outline and Mounting Dimensions for Panel Mount, 39

Figure 11: Outline and Mounting Dimensions for Panel Mount, 40

Figure 12: Connection Diagram for Low HP Panel Mount & Less Operators Controls,2450-1100-I,Rev.A..... 41

Figure 13: Connection Diagram for High HP Panel Mount & Less Operators Controls,2450-1101-I,Rev.A..... 42

Figure 14: Connection Diagram for Low HP Enclosed Controls, 2450-1000-I, Rev. A 43

Figure 15: Connection Diagram for High HP Enclosed Controls, 2450-1001-I, Rev. A 44

Figure 16: Panel Mount and Less Operators Low HP Controls with "M" Contactor, 2450-1102-I, Rev.A..... 45

Figure 17: Panel Mount & Less Operators High HP Controls with "M" Contactor,2450-1103-I,Rev.A 46

Figure 18: Panel Mount & Less Operators Low HP Controls with Reversing Kit,2450-1104-I,Rev.A 47

Figure 19: Panel Mount & Less Operators High HP Controls with Reversing Kit,2450-1105-I,Rev.A 48

Figure 20: Enclosed Low HP Control with "M" Contactor, 2450-1002-I, Rev. A..... 49

Figure 21: Enclosed High HP Control with Reversing Kit, 2450-1003-I, Rev. A..... 50

Figure 22: Enclosed Low HP Control with Reversing Kit, 2450-1004,I, Rev. A..... 51

Figure 23: Enclosed High HP Control with Reversing Kit, 2450-1005-I, Rev. A..... 52

Figure 24: Schematic Diagram Main PC Board, 2450-1000, Rev.C..... 53

Figure 25: Shunt Resistor Board for High HP Enclosed & Less Operators Controls,2450-1010,NoRev. 54

Figure 26: Example of 10 lb-ft Applied Torque 55

Figure 27: Constant Torque 56

Figure 28: Constant Horsepower 56

Figure 29: Variable Torque 56

Figure 30: Motor Armature Voltage Control and Field Control 56

Figure 31: Constant Torque Speed Range 57

SECTION 1 SAFETY

This section outlines procedures necessary to insure safe operation of any AC or DC drive. For further information, contact the Service Department at the location shown on the inside back cover of this manual.

1.1 GENERAL SAFETY PRECAUTIONS

WARNING

THIS CONTROL AND ASSOCIATED MOTOR CONTAINS HAZARDOUS VOLTAGES AND ROTATING MECHANICAL PARTS. EQUIPMENT DAMAGE OR PERSONAL INJURY CAN RESULT IF THE FOLLOWING GUIDELINES ARE NOT OBSERVED.

1. Only qualified personnel familiar with this equipment and the information supplied with it should be permitted to install, operate, troubleshoot or repair the apparatus. A qualified person must be previously trained in the following procedures:

a.) Energizing, de-energizing, clearing, grounding and tagging circuits and equipment in accordance with established safety practices.

b.) Caring and using protective equipment such as rubber gloves, hardhat, safety glasses or face shields, flash clothing, etc., in accordance with established safety practices.

c.) Rendering first aid.

2. Installation of the equipment must be done in accordance with the National Electrical Code and any other state or local codes. Proper grounding, conductor sizing and short circuit protection must be installed for safe operation.

3. During normal operation, keep all covers in place and cabinet doors shut.

4. When performing visual inspections and maintenance, be sure the incoming AC power is turned off and locked out. The drive and motor will have hazardous voltages present until the AC power is turned off. The drive contactor does not remove hazardous voltages when it is opened.

5. When it is necessary to make measurements with the power turned on, do not touch any electrical connection points. Remove all jewelry from wrists and fingers. Make sure test equipment is in good, safe operating condition.

6. While servicing with the power on, stand on some type of insulation, being sure you are not grounded.

7. Follow the instruction given in this manual carefully and observe all warning and caution notices.

1.2 INSTALLATION SAFETY

When moving this control and associated motor into the installation position, do any required lifting only with adequate equipment and trained personnel. Eyebolts or lifting hooks, when supplied, are intended for lifting the product only and must not be used to lift additional weight. *Improper lifting can cause equipment damage or personal injury.*

WARNING

HAZARDOUS VOLTAGES MAY BE PRESENT ON EXTERNAL SURFACES OF UNGROUNDED CONTROLS. THIS CAN RESULT IN PERSONAL INJURY OR EQUIPMENT.

If the drive cabinet or open chassis unit is mounted such that it is not grounded, a ground wire must be connected to the panel or enclosure frame for personnel safety. Also any motor frame, transformer enclosure and operator station must be connected to earth ground. Consult the National Electrical Code and other local codes for specific equipment grounding requirements. Protective guards must be installed around all exposed rotating parts.

CAUTION

DRILLING OR PUNCHING CAN CREATE LOOSED METAL CHIPS. THIS CAN RESULT IN SHORTS OR GROUNDS THAT CAN DAMAGE THE EQUIPMENT.

If it is necessary to drill or punch holes in the equipment enclosures of conduit entry, be sure that the metal chips do not enter the circuits.

Circuits shown on the drawings that require shielded cable is sensitive to pick-up from other electrical circuits. Examples include wiring from the tachometer and from the speed setting device. Erratic or improper operation of the equipment is likely if the following precautions are not observed:

Where shielded cable is required, use 2- or 3-conductor twisted and shielded cable with the shield either connected as shown in the drawings, or "floating", if so specified. If the shield is to be connected, do so only at the specified terminal in the drive unit. Do not connect at a remote location.

Shielded cables outside the drive enclosure should be run in separate steel conduit, and should not be mixed in with other circuits that are not wired with shielded cable.

Inside the drive equipment, whenever possible, avoid running the shielded cable close to other circuits. Avoid long parallel runs to other non-shielded circuits, and cross other cable bundles at right angles. Do not connect any external circuits to the drive or its associated equipment other than those shown on the diagrams supplied. Connection of external devices to the tachometer or speed setting device can significantly affect drive performance.

CAUTION

MEGGERING CIRCUITS CONNECTED TO THE DRIVE CAN CAUSE DAMAGE TO ELECTRONIC COMPONENTS. DO NOT MEGGER OR HI-POT THIS EQUIPMENT. USE A BATTERY OPERATED VOLT-OHM-METER (VOM) TO CHECK FOR SHORTS, OPENS OR MIS-WIRING.

CONNECTION OF UNSUPPRESSED INDUCTIVE DEVICES TO THE DRIVE POWER FEED OR CONTROL CIRCUITS CAN CAUSE MIS-OPERATION AND POSSIBLE COMPONENT DAMAGE TO THE EQUIPMENT.

DO NOT CONNECT POWER FACTOR CORRECTION CAPACITORS WITH THIS EQUIPMENT, AS THIS MAY CAUSE HIGH VOLTAGES THAT CAN DAMAGE DRIVE

1.3 START-UP SAFETY

Detailed startup procedures are described in the Operation and Startup section of this manual. Before and during startup, it is imperative that all of the following safety procedures be observed.

WARNING

AC POWER MUST BE DISCONNECTED FROM THE DRIVE CABINET TO ELIMINATE THE HAZARD OF SHOCK BEFORE IT IS SAFE TO TOUCH ANY OF THE INTERNAL PARTS OF THE DRIVE. CIRCUITS MAY BE AT LINE POTENTIAL WHETHER THE ENCLOSED DRIVE IS OPEN OR CLOSED. USE EXTREME CAUTION.

WARNING

HAZARDOUS VOLTAGES ARE PRESENT ON THE MOTOR UNTIL ALL POWER TO THE CONTROL IS DISCONNECTED. TURN OFF AND LOCKOUT ALL POWER TO THE CONTROL BEFORE TOUCHING ANY INTERNAL CIRCUITS ON THE MOTOR.

1. The use of unauthorized parts in the repair of this equipment or tampering by unqualified personnel will result in dangerous conditions, which can cause equipment damage or personal injury. Follow all safety precautions contained in this manual and all safety-warning labels on the product.
 2. Loose rotating parts can cause personal injury or equipment damage. Before starting the motor, remove all unused shaft keys and other loose parts on the motor or the rotating mechanical load. Be sure all covers and protective devices are in place. Refer to the instruction manual supplied with the motor for further information and precautions.
 3. When using an oscilloscope to make measurements in the power circuits, use the connections shown in Figure 1 and the procedures described in step 4. Failure to follow this procedure could result in the case of the oscilloscope being at line potential. Only qualified personnel should be allowed to use the oscilloscope and other test equipment.
 4. Referring to Figure 1 set the oscilloscope to add channels A & B, and invert channel B. Before making measurements, connect both probes together and set the "zero" line.
- This connection allows the oscilloscope case to be connected to ground for safe operation.

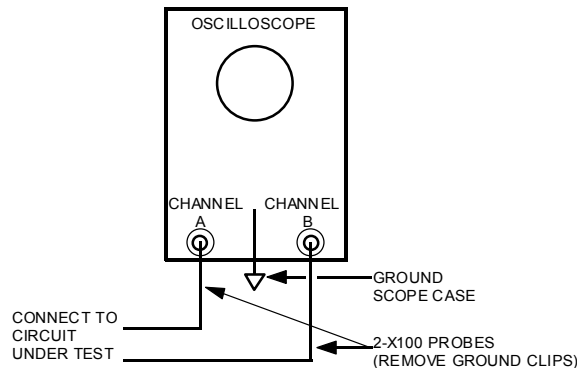

Figure 1: Oscilloscope Connections

SECTION 2 GENERAL INFORMATION

2.1 INTRODUCTION

This instruction manual contains installation information, operating instructions and troubleshooting procedures for this adjustable voltage DC drive. It also includes a complete description of the control with detailed product specifications and a complete description of all customer selectable functions and customer installable option kits.

For most drive applications, the information contained in this instruction manual will completely describe all drive system set-up and operating procedures. It should also provide all the information required by the customer to install and maintain the control. In a few applications, additional drive system set-up and operating information may be required. This information will generally be furnished in the form of system schematic and system interconnection diagrams. An overall Systems Installation Manual may also be furnished.

This instruction manual should be read in its entirety before beginning installation and before performing any start-up or maintenance on the drive system.

NOTE: The information in this manual applies to the enclosed, less operators and panel mount controls except where specifically stated otherwise.

2.2 GENERAL DESCRIPTION

The control is a high performance DC drive. It contains all the required circuitry to control the speed of, or to control the current supplied to, small horsepower shut wound or permanent magnet DC motors. It includes many standard features that are available only as options on other single-phase DC drives. This allows the control to be used in custom engineered applications as well as standard speed regulated applications.

Varying the DC voltage applied to the motor armature controls the DC motor speed, or varying the current applied to the motor armature controls the motor torque.

Single phase AC input power is converted to variable voltage DC output power by the control. In speed-regulated applications, the DC output voltage varies as a function of an input reference voltage. Typically, the input reference voltage is provided by an operator adjustable potentiometer.

Changing the potentiometer setting (reference) results in a motor speed change. In torque-regulated applications, the DC output current varies as a function of an input reference voltage. Changing the torque reference changes the current supplied to the motor and results in a change in motor torque output.

The control is designed to handle most single-phase drive applications without the need for costly, time-consuming engineering.

Simple jumper programming allows for maximum versatility in the drive. Functions such as input voltage selection (1/4 to 2HP only), armature/tachometer feedback, voltage feedback level, motor current range, and speed/torque regulation are achieved by customer selection of the jumper positions. Each control also has standard adjustments for minimum/maximum speed, IR compensation, acceleration/deceleration time and current limit.

An enclosed, less operators, and panel mount control design is available. Two models are provided for each design—a low horsepower (1/4-2HP) model and a high horsepower (3-5HP) model.

2.3 TYPICAL PACKAGING

NOTE: THE ENCLOSED CONTROL ALONG WITH THE LESS OPERATORS CONTROL ARE NO LONGER MANUFACTURED. THE INFORMATION REGARDING THESE CONTROLS IS FOR RECONDITIONED DRIVES ONLY.

The enclosed controls are furnished in a standard enclosure rated to meet or exceed NEMA type 1, 4, 12 and 13 requirements. The enclosure package consists of two halves of a hinged shell, which are opened by releasing a spring-loaded screw on the right side of the cover. The inside of the cover contains the switches and heat sink. The inside of the base contains the main PC board. The function of which are described in detail in Sections 4 and 5. The inside of the base on the 3-5HP enclosed and less operators' models also contains the shunt resistor PC board.

The enclosed controls are equipped with pre-installed on/off, run/jog, and start/stop switches and a 1-turn speed potentiometer.

The less operators' controls are furnished in the same enclosure design as the enclosed controls except for ventilation holes provided in each end of the cover. End cover plate can be installed as an option to cover these ventilation holes and convert this control to a NEMA 4/12 enclosure without operators. A remote operator station must then be used for operator controls. A loose speed pot is furnished with the control.)

The panel mount controls are suitable for sub panel mounting inside a customer supplied control enclosure.

The operators for the panel mount control are customer supplied except for the speed potentiometer, which is supplied loosely with the control.

2.4 EQUIPMENT IDENTIFICATION

It is important to identify the control completely and accurately whenever ordering spare parts or requesting assistance in service.

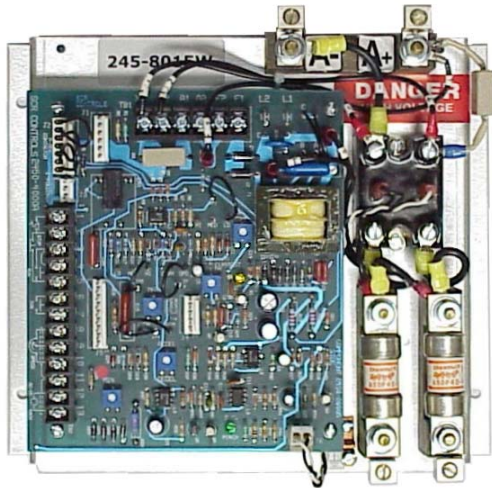

Figure 3: Panel Mount Control

The enclosed controls include a product nameplate located on the bottom edge of the cover.

The less operators' controls include a product nameplate located on the front cover.

The panel mount controls include a product nameplate located on the right edge of the chassis as shown in

The product nameplate should appear similar to the sample nameplate shown in Figure 2.

For any of these controls, record the part number (P/N), revision level (REV), and DATE for future reference in the front of this manual.

If the control is part of an engineered drive system, the system cabinet will also include a product nameplate. Record the part number, and serial number (S/N) of the engineered system and include this information with the information on the individual controls whenever contacting the factory.

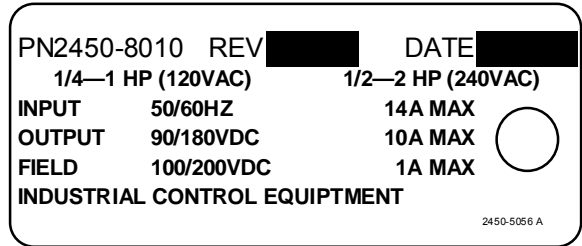

Figure 2: Typical Panel Mount Control Product Nameplate

SECTION 3 CONTROL SPECIFICATIONS AND FEATURES

3.1 EQUIPMENT RATINGS

The 1/4--2HP enclosed, less operators and panel mount controls can be programmed for 120 VAC input (1/2—1HP) or 240VAC input (1/2 – 2HP). The 3—5HP enclosed, less operators and panel mount controls can be programmed only for a 240VAC input. Table 1 summarizes the horsepower outputs available in each programming mode.

Table 1: Control Rating Table

AC Input**		HP	DC Armature Output		DC Field Output	
Volts	Amps		Volts	Amps*	Volts	Amps*
120	3.6	1/4	90	2.6	100	1
VAC,	5.2	1/3	90	3.7	100	1
1Ø	7.7	1/2	90	5.5	100	1
50/60	10.5	3/4	90	7.5	100	1
HZ	14	1	90	10	100	1
240	3.6	1/2	180	2.6	200	1
VAC,	5.2	3/4	180	3.7	200	1
1Ø,	7.7	1	180	5.5	200	1
50/60	10.5	1-1/2	180	7.5	200	1
HZ	14	2	180	10	200	1
	21	3	180	15	200	1
	35	5	180	25	200	1

* These are typical motor current ratings. See motor nameplate for exact current ratings.

** The input voltage and current (amp) values are approximate. Actual values may vary depending on input voltage, input line impedance, and actual motor efficiency.

3.2 SERVICE CONDITIONS

ENCLOSURE: Chassis (panel mount)
Open enclosure (less operators) with NEMA 4/12 Option*
NEMA 4/12 (enclosed)

HORSEPOWER RATINGS:

Input power:
120VAC, 1 phase, 50/60Hz: 1/4--1HP
240VAC, 1 phase, 50/60Hz: 1/2--2HP (Re-connectable dual voltage)
240VAC, 1 phase, 50/60Hz: 3-5HP(single voltage)

LINE VOLTAGE VARIATION: ±10%

*Designed to meet NEMA 4 and 12 requirements but not submitted for listing.

LINE FREQUENCY VARIATION: 48-62Hz
FIELD SUPPLY: 1 Amp
MAXIMUM ALTITUDE (Without derating): 3,300 ft above sea level
AMBIENT TEMPERATURE:
Panel Mount and Less Operators: 0°C to 55°C (32°F to 131°F)
Enclosed Control: 0°C to 40°C (32°F to 104°F)

SPACE REQUIREMENT FOR PANEL MOUNT CONTROL IN TOTALLY ENCLOSED NON-VENTILATED ENCLOSURE: 20"x20"x8" or 24"x20" x6"
AC LINE FUSES: 1/4-2HP: 15A, 250V
3-5HP: 40A, 500V

3.3 PERFORMANCE SPECIFICATIONS

SERVICE FACTOR: 1.0 maximum rating
SPEED REGULATION:
For a 95% Load Change using Armature Voltage Feedback with IR Compensation:
±1% of maximum speed
For All Other Variables (Voltage Regulated):
Changes up to 15% of top speed can result from temperature, voltage, frequency variations plus drift.
With AC Tachometer** Feedback:
±1/2 % of base speed due to load variations. ± 1% of base speed due to variations in ambient conditions or line voltage.
With DC Tachometer** Feedback:
±1/2 % of base speed due to variations in load, line voltage or ambient conditions.
OVERLOAD CAPACITY (As a percent of maximum rating): 150% for one minute

EFFICIENCY:
Control Only (Minimum) 98%
Motor and Control (Typical) 86%
CURRENT LIMIT: 0-150%
ACCELERATION/DECELERATION TIME: 2 to 30 seconds (linear)
** Actual percentages may vary depending on the type of tachometer used.

3.4 OPERATOR FUNCTIONS

SPEED ADJUSTMENT Standard
POWER ON/OFF
Enclosed: Standard
Less Operators: Optional
Panel Mount: Customer supplied
START/STOP, RUN/JOG:
Enclosed: Standard
Less Operators: Customer supplied
Panel Mount: Customer supplied
FORWARD/REVERSE, AUTO/MANUAL Optional

3.5 POTENTIOMETER ADJUSTMENTS

The standard control includes five (5) customer adjustable potentiometers, which are located on the main PC board. These potentiometers have been preset. However, for proper operation in some applications, minor readjustments may be necessary during drive installation and startup.

MAXIMUM SPEED: 70 to 120% of rated speed
 MINIMUM SPEED: 0 to 30% of maximum speed
 IR COMPENSATION: 0 to 20% of rated voltage (at rated current)
 CURRENT LIMIT: 0 to 150% of selected rating
 ACCELERATION/
 DECELERATION: 2 to 30 seconds (linear)

3.6 CUSTOMER PROGRAMMABLE SELECTIONS (JUMPERS)

MODE OF CONTROL: Speed or torque
 Regulation
 OPERATING VOLTAGE: 120 or 240VAC
 (1/4-2HP controls only)
 FEEDBACK METHOD: Armature or tachometer feedback
 VOLTAGE FEEDBACK LEVEL: High, Med., Low
 CURRENT FEEDBACK LEVEL: High, Med., Low

3.7 STANDARD FEATURES

- Control relay providing momentary Start/Stop operation. Control cannot restart without pushing Start button if AC power is momentarily disconnected and restored.
- Both AC lines fused for maximum semiconductor protection in case of short circuit.
- Designed for use with 50 or 60 Hz AC power.
- LED (light emitting diode) indicator lights to indicate if control is in current limit and to indicate SCR gate triggering.
- Continuous full rated torque available over a 30:1 speed range.
- Tachometer feedback circuitry is standard. Addition of AC or DC tachometer generator to the motor converts the drive from armature to tachometer feedback for improved speed regulation.
- Selectable current limit ranges to match control to the motor being used. Provides overload protection and smooth acceleration of high inertia loads.
- Varistor transient voltage protection providing trouble-free operation.
- Jog at run speed standard.
- Zener regulated control power supply provides compensation for line voltage fluctuation.
- UL listed and CSA approved.

3.8 PRE-ENGINEERED MODIFICATION KITS

The control can be purchased alone or with a selected group of pre-engineered modification kit. These kits allow the customer to create a custom engineered control to meet individual specific requirements. Each modification kit is individually packaged, identified, and includes all mounting hardware, wire, terminals, cable ties, labels and instructions. Following is a brief description of the modification kits currently available.

CAUTION

THESE MODIFICATIONS KITS ARE THE ONLY KITS DESIGNED FOR USE WITH THIS CONTROL. ANY MODIFICATIONS OTHER THAN THOSE SPECIFIED VOIDS ALL WARRANTIES, STATED OR IMPLIED.

3.8.1 "M" CONTACTOR KIT

This kit is a magnetic contactor mounted on a printed circuit board. (See Figure 4) It provides a positive disconnect of the motor armature when the control is stopped, preventing motor turnover in case the SCRs should false fire. In addition, an auxiliary form C contact rated for 1 amp at 120VAC is included for customer use when needed. Note that this kit may be required by local and/or national electrical codes. The option-mounting panel is needed with panel mount controls.

3.8.2 JOG AT JOG SPEED KIT

This kit provides a separate internal potentiometer for controlling the motor speed when operating in the jog mode, (See Figure 4). The kit automatically switches speed control from the normal run speed potentiometer to the jog speed potentiometer when the control switches to the jog mode. The jog speed is adjustable from 0 to 30% of the control maximum speed setting.

3.8.3 MAGNETIC REVERSING KIT

This kit provides full armature reversing using a forward and a reverse contactor mounted on a printed circuit board with an anti plugging circuit, (See Figure 4). A forward/reverse toggle switch is included to select the direction of motor rotation. The electrical code requirements for an "M" contactor are also satisfied since the forward and reverse contactors disconnect the motor armature from the control when the motor is stopped. An auxiliary form C contact rated for 1 amp at 120VAC is included on the printed circuit board for customer use when needed. The option-mounting panel is needed with panel mount controls.

3.8.4 CURRENT SIGNAL FOLLOWER

This kit permits the speed of the DC motor to be controlled by a milliampere signal from a commercially available transducer. The signal may be any one of the following:

1-5mA 4-20mA 10-50mA

Transducers, which produce these current ranges, are available for sensing temperature, weight, flow rate, pressure, pH and many other variables and must be supplied by the customer. The applied current signal must be ungrounded and isolated from the control AC power sources, or an isolation transformer must be used. This kit also provides an auto/manual switch so that control can be switched from the external signal to manual speed adjustment using the speed potentiometer.

3.8.5 VOLTAGE SIGNAL FOLLOWER

This kit allows the motor speed to be controlled by a voltage signal from an AC or DC tachometer generator or a process voltage signal (See). The kit consists of a printed circuit board and an auto/manual toggle switch for switching from automatic control by the voltage signal to manual control by the speed potentiometer. The printed circuit board is designed to accept voltage signal inputs with a range of 0 to 200 volts AC or DC with a calibration potentiometer provided to adjust the unit for the signal that is available. The voltage signal input must be ungrounded and isolated from the AC power source and from any other controls which use the signal. If the signal is not isolated, an isolation transformer must be used.

3.8.6 TORQUE TAPER/REMOTE CURRENT LIMIT KIT

This kit consists of a printed circuit board with two related functions:

1. Remote Current Limit Adjustment—permits adjustment of the control current limit setting with an external 5000 ohm, 2-watt potentiometer (not provided in kit).
2. Torque Taper Adjustment—provides an internal means of adjusting the speed vs. torque limit relationship of the drive so that the motor torque limit relationship of the drive so that the motor torque limit will gradually drop off as motor speed increases.

This kit is shown in Figure 4.

3.8.7 DYNAMIC BRAKING KIT

This is for use with either the “M” Contactor Kit or the Magnetic Reversing Kit. Dynamic braking causes the motor to decelerate rapidly to a stop with braking torque of approximately 150% of the motor full load torque rating at full speed. This is accomplished by a resistor(s) connected across the armature to absorb the energy of the coasting motor (now acting as a generator). Dynamic braking is not a “holding” (fail-safe) brake and cannot be used as such. The dynamic braking resistors have been sized to provide the proper amount of braking torque when used with company supplied DC motors with no appreciable inertia connected to the motor shaft. The resistors are designed to withstand stopping frequencies less than or equal to the following:

Fractional HP 1 stop per 70 seconds

Integral HP 3 quick stops within 7 minutes before the next stop.

For inertial loads, more frequent stopping than specified above, or motors that are not company supplied, consult your company distributor for analysis and proper dynamic braking resistor selection.

The option-mounting panel is needed with panel mount controls.

3.8.8 AC POWER DISCONNECT SWITCH

This double pole AC disconnect switch is the same AC power disconnect switch provided as a standard feature on the enclosed control operator panel. It may be added to the less operators control when a local AC power disconnect switch is desired.

3.8.9 END COVER PLATES

The standard less operators control is provided with ventilation holes in each end. The end cover plates may be used to cover these ventilation holes and convert the less operators control to an enclosed control without operators. A gasket is provided so that the enclosure is rated NEMA 4/12. A remote operator station must then be used for operator controls.

3.8.10 SPARE PARTS KIT

For most customers this kit provides all the spare parts ever required. The kit contains three complete sets of fuses (6 fuses) and an SCR power cube.

3.8.11 REMOTE STATION

This NEMA 1 rated kit can operate the SCR drive from a remote location. It includes start and stop momentary push buttons and a speed potentiometer with provision for adding a jog selector switch.

3.8.12 TEN TURN POTENTIOMETER KIT

This kit may be used to replace the standard single-turn potentiometer in the control to provide a much finer adjustment of the speed (or torque when the unit is used as a torque control). The potentiometer may also be used in conjunction with the Torque Taper/Remote Current Limit Kit to provide an external current limit adjustment for the control. Included are the ten-turn potentiometer and a digital turns-indicating knob suitable for mounting in the operator panel on the control enclosure or in a remote operator station. When using this Ten-Turn Potentiometer in an enclosed control, the enclosure rating is NEMA 1.

3.8.13 SPEED METER KITS

The Speed Meter Kits provide a visual indication of DC motor speed. They may be used to indicate DC Motor Speed by monitoring the output voltage of a motor mounted AC or DC tachometer generator. They may also be used to indicate DC motor speed by monitoring DC motor armature voltage, which is directly proportional to motor speed. The Speed Meter Kits may be used with either a 90VDC or 180VDC armature voltage, which is directly proportional to motor speed. The Speed Meter Kits may be used with either a 90VDC or 180VDC

armature voltage input. They may also be used with any of the AC or DC tachometers listed in the price book. A printed circuit board is included and mounted on the back of the meter to allow calibration of the Speed Meter for use with a wide range of inputs. When used in conjunction with a motor mounted tachometer, the Speed Meter Kit will provide an indication of motor speed with $\pm 2\%$ accuracy. When used with an armature voltage input, the Speed Meter Kit provides motor speed indication with an accuracy of $\pm 5\%$.

The Speed Meter Kits are supplied in a NEMA 1 enclosure suitable for wall mounting. They may be easily removed from their enclosures for panel mounting.

3.8.14 OPTION MOUNTING PANEL

This option provides mounting space for the reversing, armature contactor and dynamic braking options when used with the panel mount control. It comes pre-drilled ready for immediate assembly.

3.8.15 DEAD FRONT

This kit is intended primarily for field installation on an existing panel mount control. For most new applications, it would be advisable to use the less operators' control.



Remote Current Limit/Torque Taper



Jog at Jog Speed



Voltage Signal Follower

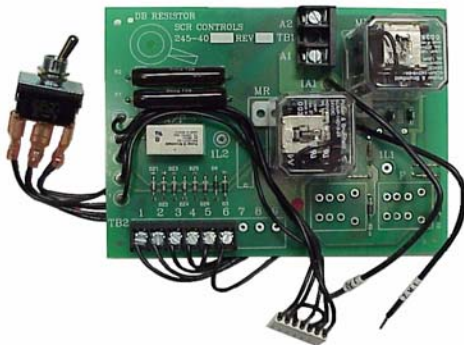

Reversing



"M" Contactor

Figure 4: Control Modification Kits

SECTION 4 INSTALLATION

4.1 SAFETY WARNINGS

Improper installation or operation of this control may cause injury to personnel or damage to equipment. Read the operating instructions. The control and its associated motors and operator control devices must be installed and grounded in accordance with all local codes and the National Electrical Code (NEC). To reduce the potential for electric shock, disconnect all power sources before initiating any maintenance or repairs. Keep fingers and foreign objects away from ventilation and other openings. Keep air passages clear. Potentially lethal voltages exist within the control unit and connections. Use extreme caution during installation and start-up.

4.2 INITIAL CHECKS

Before installing the control, check the unit for physical damage sustained during shipment. If damaged, file claim with shipper and return for repair following procedures outlined on the back cover. Remove all shipping restraints and padding. Check nameplate data for conformance with the AC power source and motor.

4.3 CONTROL JUMPER PROGRAMMING

Prior to installing the control, the jumpers must be programmed for all of the following:

1. Using the correct AC line voltage.
2. Using either the speed or torque regulated mode of operation.
3. Choosing either armature voltage or tachometer feedback.
4. Choosing the correct voltage feedback level.
5. Matching the control to the motor being used.

These programming jumpers, labeled JA, JB, and JP1 through JP4 on the main PC board (which is common to all six control models) are jumper wires that are connected to terminal pins as described as follows. All of these jumpers are illustrated in Figure 5.

These jumpers perform the following functions:

JA & JB – Transformer Programming Jumper – programs unit for correct AC input voltage.

JP1 – Current Feedback Level Jumper – Sets current limit and IR Compensation adjustment ranges to properly match the control to the motor being used.

JP2 - Voltage Feedback Level Jumper – Sets voltage feedback level for 90 VDC or 180 VDC armature output with armature feedback, or programs the unit to accept tachometer feedback voltages of different levels.

JP3 – Mode of Operation Jumper – Programs control as a speed or torque regulated control.

JP4- Voltage Feedback Selection Jumper – Selects either armature feedback or tachometer feedback as the voltage feedback source.

Refer to the following paragraphs and Table 1, and Table 2, for determining the correct jumper connections. After the jumper programming is completed, the jumper positions can be recorded for future reference on the Customer jumper Programming Chart Table 5.

WARNING

EQUIPMENT DAMAGE AND/OR PERSONAL INJURY MAY RESULT IF ANY JUMPER PROGRAMMING IS ATTEMPTED WHILE THE CONTROL IS OPERATIONAL. ALWAYS LOCK OUT POWER AT THE REMOTE DISCONNECT BEFORE CHANGING ANY JUMPER POSITIONS.

4.3.1 OPERATING VOLTAGE SELECTION

The first step is programming the control is determining what AC input voltage is required. This is determined by the motor to be used. If the motor is rated ¼ to 1HP and has a 90VDC armature with either a 100VDC or permanent magnet field, then 120VAC input power is required. If the motor rating is ½ to 5HP and has a 180VDC armature with either a 200VDC or permanent magnet field, then a 240VAC input source is required. Motors other than these cannot be used with these controls. Refer to the motor nameplate for this information.

A. If the control is operating on 120VAC input and 0-90VDC output:

Connect jumper **A** to the **E** position and jumper **B** to the **D** position.

B. If the control is operating on 240VAC input and 0-180VDC output:

Connect jumper **A** to the **C** position and jumper **B** to the **C** position.

WARNING
NEVER ATTEMPT TO CONVERT ¼ - 2HP CONTROLS TO ANY OPERATING VOLTAGE OTHER THAN 120VAC INPUT/0—90VDC OUTPUT OR 240 VAC INPUT/0-180VDC OUTPUT. NEVER ATTEMPT TO CONVERT 3—5HP CONTROLS TO ANY OPERATING VOLTAGE OTHER THAN 240VAC INPUT/0-180VDC OUTPUT. ANY SUCH ATTEMPTED CONVERSION CAN CAUSE EQUIPMENT DAMAGE AND POSSIBLE PERSONAL INJURY.

4.3.2 MODE OF CONTROL SELECTION

Next it must be determined if the unit is going to be used as a speed or torque control. When used as a speed control, the operation control potentiometer

sets the motor RPM, and the motor produces only the torque necessary to drive the load at this RPM.

This is the type control used on most applications. If, however, the unit is connected as a torque control (used mainly on surface winders), the operator control potentiometer sets the motor torque, and the motor will run at an RPM determined by the torque – speed characteristics of the driven load.

A. If the unit is to control speed: - Place **JP3** in the **SPD** position

B. If the unit is to control torque (speed): - Place **JP3** in the **CURR** position.

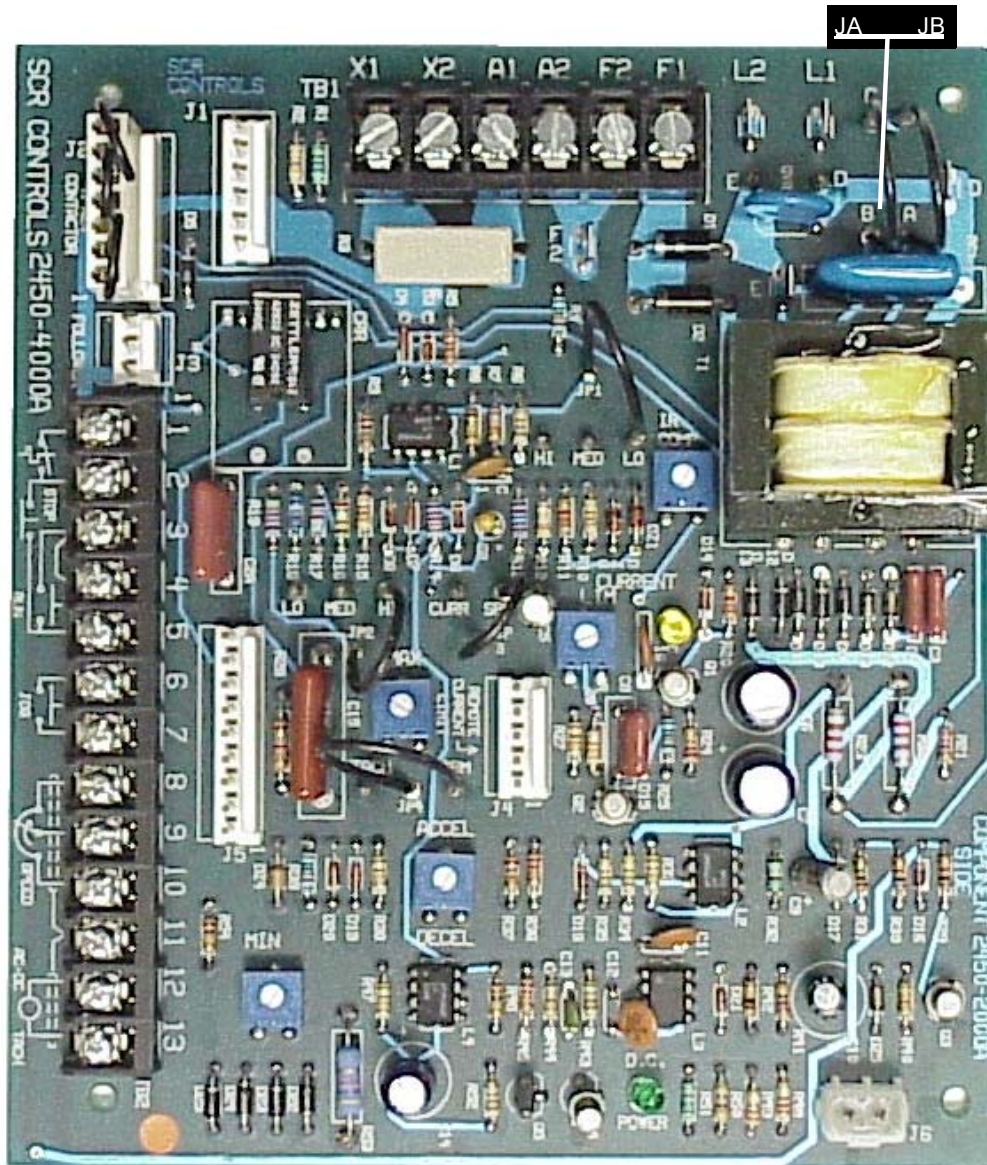

Figure 5: Main PC Board Jumper Locations

CAUTION

WHEN USING THE UNIT AS A TORQUE CONTROL, OBSERVE THE FOLLOWING PRECAUTIONS: (1) IF LOAD TORQUE IS REMOVED OR REDUCED TO A LEVEL BELOW THE TORQUE SETTING, MOTOR RPM COULD INCREASE TO DANGEROUS LEVELS. FOR THIS REASON, PROTECTION AGAINST OVERSPEEDING IS RECOMMENDED. (2) IF LOAD TORQUE EXCEEDS CONTROL TORQUE SETTING, MOTOR WILL STALL. LEAVING MOTOR IN STALLED CONDITION FOR EXTENDED PERIODS CAN CAUSE MOTOR OVERHEATING AND WINDING INSULATION DAMAGE.

4.3.3 ARMATURE OR TACHOMETER FEEDBACK SELECTION

When the control is to be used as a speed control, armature or tachometer voltage feedback is required. Armature feedback is standard, but if an application requires closer regulation of the motor RPM, then tachometer feedback may be added to the drive. This requires that an AC or DC tachometer generator be coupled to the motor shaft and the voltage produced by this generator is then used to provide voltage feedback to the control.

- If the unit is to have armature voltage feedback (when in the speed control mode):
 1. Place JP4 in the ARM position.
- If the unit is to have tachometer voltage feedback (when in the speed control mode):
 1. Place JPR in the TACH position.
 2. Mount an AC or DC tachometer generator on the drive motor.
 3. Connect generator leads to terminals 12 and 13 of terminal strip TB2 on the main control PC board. Polarity is not important. Make this connection using two conductor No.18AWG insulated, shielded cable.
 4. Connect shielding material to terminal 11 of terminal strip TB2 on the main control PC board. Carefully tape off the shield at tachometer generator with electrical tape so that it is well insulated.

CAUTION

MAKE NO OTHER CONNECTIONS TO THE SHIELDING.

- If the unit is used as a torque (current) control, voltage feedback is not required, and the voltage feedback circuit must be disabled. This is done by setting jumper **JP4** to the **TACH** position with no tachometer generator connected to the control. This causes the outer speed loop to be made inactive, and the output is controlled by the inner current loop, using what was the

“speed pot” as an adjustable current reference pot.

4.3.4 VOLTAGE FEEDBACK LEVEL SELECTION

The voltage feedback circuit in the control must be capable of accepting different levels of voltage feedback since the voltage feedback may come from a 90VDC armature, a 180VDC armature or a tachometer generator. This circuit is switched to accept different voltage levels by jumper JP2. If armature voltage feedback is used:

- If armature voltage feedback is used:
 - Set JP2 to the **LO** position for use with a 90VDC armature.
 - Set JP2 to the **HI** position for use with a 180VDC armature.

See the motor nameplate for armature voltage rating

- If using a tachometer generator for the voltage feedback, the setting of jumper JP2 depends on the voltage output from the tachometer generator with the motor rotating at its base speed:

TACHOMETER GENERATOR VOLTAGE AT BASE SPEED	JP2
54 to 126 Volts	LO
100 to 172 Volts	MED
162 to 234 Volts	HI

Setting this jumper incorrectly results in the wrong voltage feedback level to the control, thus causing the motor top speed to be too high or too low.

- If the unit is used as a torque (current) control, the voltage feedback circuit is disabled and JP2 is simply set to the **LO** position.

4.3.5 CURRENT FEEDBACK LEVEL SELECTION

The control is designed to control motors rated from ¼ to 5HP that have a wide range of current ratings. Because of this, the current feedback must be scaled so that the proper level of IR compensation and correct current limit setting are attainable with each motor. The control can be matched for low, medium or high current feedback levels by setting jumper JP1 as follows:

- A. Refer to the motor nameplate for the horsepower rating and the DC armature voltage and current (amperes).
- B. Use this data to determine the proper position of JP1 (LO, MED or HI) from Table 2 or Table 3.

Table 2: Jumper Programming for Speed Regulated Operation

AC INPUT ²			DC ARMATURE OUTPUT		DC FIELD OUT		TRANSFORMER PROGRAMMING JUMPERS	TORQUE CONTROL JUMPER PROGRAMMING			
VOLTS	AMPS	HP	VOLTS	AMPS ¹	VOLTS	AMPS ¹		JP1 ³	JP2 ⁴	JP3	JP4 ⁴
120	3.6	¼	90	2.6	100	1	A-E; B-D	LO	LO	SPD	ARM
VAC,	5.2	⅓	90	3.7	100	1	A-E; B-D	LO	LO	SPD	ARM
1Ø	7.7	½	90	5.5	100	1	A-E; B-D	LO	LO	SPD	ARM
50/60	10.5	¾	90	7.5	100	1	A-E; B-D	MED	LO	SPD	ARM
Hz	14	1	90	10	100	1	A-E; B-D	HI	LO	SPD	ARM
240	3.6	½	180	2.6	200	1	A-C; B-C	LO	LO	SPD	ARM
VAC,	5.2	¾	180	3.7	200	1	A-C; B-C	LO	LO	SPD	ARM
1Ø	7.7	1	180	5.5	200	1	A-C; B-C	LO	LO	SPD	ARM
50/60	10.5	1.5	180	7.5	200	1	A-C; B-C	MED	LO	SPD	ARM
Hz	14	2	180	10	200	1	A-C; B-C	HI	LO	SPD	ARM
	21	3	180	15	200	1	A-C; B C	LO	LO	SPD	ARM
	35	5	180	25	200	1	A-C; B-C	HI	LO	SPD	ARM

1. These are typical motor current ratings. See motor nameplate for exact current ratings.
2. The input voltage and current (amps) values are approximate. Actual values may vary depending on input voltage, input line impedance and actual motor efficiency.
3. JP1 sets the following current limit levels that are adjustable from 0 to 100% in the torque mode.

	¼-2 HP	3-5HP
LO	6.0 Amps	15 Amps
MED	8.2 Amps	18.6 Amps
HI	10.8 Amps	25 Amps

4. If using a tachometer generator for voltage feedback:
 - A. Place JP4 in the TACH position.
 - B. Select proper position for JP2 by determining maximum tach generator voltage at maximum speed. Select appropriate range allowing sufficient range above and below for calibration by adjustment of the maximum speed pot.

LO	54V to 126V
MED	100V to 172V
HI	162V to 234V

For example: Using a 50V/100RPM tach:

Base	Base/1000	X Tach V	Max Tach Volt	Use
1750	1.75	50	87.5V	LO
2500	2.5	50	125V	MED
3000	3.0	50	150V	MED

Table 3: Jumper Programming for Torque Regulated Operation

AC INPUT ²			DC ARMATURE OUTPUT		DC FIELD OUT		TRANSFORMER PROGRAMMING JUMPERS	TORQUE CONTROL JUMPER PROGRAMMING			
VOLTS	AMPS	HP	VOLTS	AMPS ¹	VOLTS	AMPS ¹		JP1 ³	JP2 ⁴	JP3	JP4 ⁴
120 VAC, 1Ø 50/60 Hz	3.6	¼	90	2.6	100	1	A-E; B-D	LO	LO	CURR	TACH
	5.2	⅓	90	3.7	100	1	A-E; B-D	LO	LO	CURR	TACH
	7.7	½	90	5.5	100	1	A-E; B-D	LO	LO	CURR	TACH
	10.5	¾	90	7.5	100	1	A-E; B-D	MED	LO	CURR	TACH
	14	1	90	10	100	1	A-E; B-D	HI	LO	CURR	TACH
240 VAC, 1Ø 50/60 Hz	3.6	½	180	2.6	200	1	A-C; B-C	LO	LO	CURR	TACH
	5.2	¾	180	3.7	200	1	A-C; B-C	LO	LO	CURR	TACH
	7.7	1	180	5.5	200	1	A-C; B-C	LO	LO	CURR	TACH
	10.5	1.5	180	7.5	200	1	A-C; B-C	MED	LO	CURR	TACH
	14	2	180	10	200	1	A-C; B-C	HI	LO	CURR	TACH
	21	3	180	15	200	1	A-C; B C	LO	LO	CURR	TACH
	35	5	180	25	200	1	A-C; B-C	HI	LO	CURR	TACH

1. These are typical motor current ratings. See motor nameplate for exact current ratings.

2. The input voltage and current (amps) values are approximate. Actual values may vary depending on input voltage, input line impedance and actual motor efficiency.

3. JP1 sets the following current limit levels that are adjustable from 0 to 100% in the torque mode.

LO	6.0 Amps
MED	8.0 Amps
HI	10.7 Amps

Do not use a tachometer generator when in the torque regulation mode. By putting the control in the TACH feedback setting without a tachometer input and with JP3 in the current mode, the outer speed loop is made inactive. The output is controlled by the inner current loop, using what was the “speed pot” as an adjustable current reference pot.

4.4 DETERMINING THE CONTROL LOCATION

The control is suitable for most well-ventilated factory areas where industrial equipment is installed. Locations subject to steam vapors, excessive moisture, oil vapors, flammable or combustible vapors, chemical fumes, corrosive gases or liquids, excessive dirt, dust or lint should be avoided unless an appropriate enclosure has been supplied or a clean air supply is provided to the enclosure. The location should be dry and the ambient temperature should not exceed 55°C for panel mount and less operators' controls, or 40°C for enclosed controls. If the mounting location is subject to vibration, the unit should be shock mounted.

If the enclosure is force ventilated, avoid, wherever possible, and environment having a high foreign matter content as this requires frequent filter changes or the installation of micron-filters. Should the control enclosure require cleaning on the inside, a low pressure vacuum cleaner is recommended. Do not use an air hose because of the possibility of oil vapor in the compressed air and the high air pressure.

4.5 INSTALLING PANEL MOUNT AND LESS OPERATORS CONTROLS

The panel mount control is suitable for mounting in a user's enclosure where internal temperature will not exceed 55°C. When mounting the less operators' control, insure that the ventilation hole in each end of the box provided is clear.

The following procedure is recommended. Mount the control vertically against the mounting surface. Dimensions are shown in Figure 10 and Figure 11.

CAUTION
NEVER OPERATE THE CHASSIS CONTROL FOR AN EXTENDED TIME ON ITS BACK. DOING THIS MAY CAUSE THE HEAT FROM THE HEAT SINK TO PENETRATE THE CONTROL LOGIC WIRING.

4.6 INSTALLING ENCLOSED CONTROLS

Enclosed controls are suitable for wall mounting in an ambient atmosphere between 0°C and 40°C. Mount the control to provide access to the front panel. See Figure 10 and Figure 11 for dimensions.

CAUTION
THE NON-METALLIC ENCLOSURE ON ENCLOSED AN LESS OPERATORS' CONTROLS DOES NOT PROVIDE GROUNDING BETWEEN CONDUIT CONNECTIONS. USE GROUNDING TYPE BUSHINGS AND JUMPER WIRES. IN MAKING CONDUIT CONNECTIONS, THE HUB MUST BE ASSEMBLED TO THE CONDUIT BEFORE IT IS CONNECTED TO THE ENCLOSURE.

4.7 POWER WIRING

Throughout the following discussion, reference to Figure 6 and to the connection and schematic diagrams shown in Figure 12 through Figure 15 and Figure 24 and Figure 25 .

4.7.1 INCOMING POWER REQUIREMENTS

A remote fused AC line disconnect or circuit breaker is required by the National Electrical Code. This AC line disconnect or circuit breaker must be installed in the incoming AC power line ahead of the control.

The control will operate from typical AC power lines. The line should be monitored with an oscilloscope to insure that transients do not exceed limitations as listed below:

1. Repetitive line spikes of less than 10 microseconds must not exceed the following magnitude.
 - 120 Volt Programming: 200V Peak
 - 240 Volt Programming: 400V Peak
2. Non-repetitive transients must not exceed 25 watt seconds of energy. Transients of excessive magnitude or time duration can damage dv/dt networks or surge suppressors.
3. Line notches must not exceed 300 microseconds in duration. An abnormal line condition can reflect itself as an intermittent power unit fault. High amplitude spikes or excessive notch conditions in the applied power could result in a power unit failure.

The control is designed to accept signal phase AC line voltage. See Table 1 for drive input and output ratings. When using single phase power, connect the incoming lines to terminals L1 and L2. On enclosed and less operators' controls, L1 and L2 are located in the bottom base half of the enclosure in the upper right-hand corner. On panel mount controls, L1 and L2 are in the lower right-hand corner of the chassis. Either incoming line can be connected to either of the L1 and L2 terminals.

WARNING
CONNECTING THE INPUT AC POWER LEADS TO ANY TERMINALS OTHER THAN L1 AND L2 WILL CAUSE AN IMMEDIATE FAILURE OF THE CONTROL.

CAUTION
THE VOLTAGE OF THE INCOMING LINE TO THE CONTROL MUST BE 240VAC (±10%), 50/60HZ (±2HZ), OR 120VAC (±10%), 50/60HZ (±2HZ), DEPENDING ON THE JUMPER PROGRAMMING DESCRIBED IN PARAGRAPH 4.3. IF THE INCOMING LINE VOLTAGE AND OR OUT OF THIS TOLERANCE, THE CONTROL WILL FAIL TO OPERATE.

4.7.2 OUTPUT POWER RANGES

Table 2 and Table 3 list the AC line voltages, line currents (amps), and DC field output currents (amps) for various motor horsepower ratings. The AC line amps (RMS) should be used to size the wire for both the armature output and the AC line input connections. The field current is less than one (1) ampere for each of the motors listed. The wire for field connections can be sized accordingly.

4.7.3 OUTPUT TERMINAL INSTALLATION CHECKS

It is imperative that the control be connected to earth ground for the safety of the operating personnel. This ground is provided by an enclosure or chassis-installed screw. On enclosed and less operators' controls, this ground screw is mounted to the bottom base half of the enclosure above the upper right-hand corner of the main PC board. Panel mount controls have the screw mounted on the chassis near the lower right-hand corner of the main PC board.

CAUTION
NO POINTS IN THE CONTROL CIRCUITRY, INCLUDING COMMON, SHOULD BE CONNECTED TO EARTH GROUND UNLESS SPECIFICALLY SHOWN ON THE SUPPLIED WIRING DIAGRAMS. NO GROUNDING CONNECTIONS SHOULD BE MADE ON THE TERMINAL BLOCK. IMPROPER CONNECTIONS TO GROUND, INCLUDING SPEED POTENTIOMETER CONNECTIONS, WILL RESULT IN CONTROL FAILURE.

After connecting the motor to the control and grounding, the following readings across terminals A1 and A2 (or A- and A+ for 30 HP panel mount controls), F1, F2 and GND should be verified. The reading connections for terminals A1 and A2 or A- and A+ must be made where the actual DC motor connection is made as described in "Output Power Connections". Terminals F1 and F2 are located on TB1 on the main PC board. The GND terminal is located as described earlier in this paragraph. Perform these checks before connecting the AC power input.

In making the readings listed in the following table, use volt-ohm-millimeter.

WARNING
DO NOT USE A VACUUM TUBE VOLTMETER OR OTHER SIMILAR TYPE OF METER THAT REQUIRES AC POWER FOR OPERATION.

Using red as the positive lead, make the following checks:

Checks		Range of Acceptable Readings
Red +	Black --	
A2 (or A+)	A1 (or A-)	1-4 ohms
F2	F1	100-400 ohms*
F1, F2, A1, A2	GND	Infinite
*Provided motor has wound field		

If any of the above checks are not within the indicated range, verify all connections and recheck.

As a recommended safety practice, use and isolated transformer to reduce the possibilities of ground paths.

4.7.4 OUTPUT POWER CONNECTION

The DC motor connects to terminals A1 and A2 of TB1 for all ¼ - 2 HP controls. The motor connects to terminals A1 and A2 of the shunt resistor PC board (P/N 2450-4010) for 3-5 HP enclosed and less operators' controls. This board is located in the bottom base half of the enclosure near the upper left-hand corner of the main PC board. With 3—5HP panel mount controls, the DC motor connects to the A- and A+ lugs located in the upper right hand corner of the chassis. These connections are shown in Figure 6.

CAUTION
NEVER ATTEMPT TO WIRE THE DC MOTOR DIRECTLY TO TERMINALS A1 AND A2 OF TB1 ON ANY 3—5HP CONTROL. DOING THIS CAN CAUSE THE CONTROL TO GO INTO A "CURRENT LIMIT" CONDITION.

Terminals F1 and F2 on TB1 are for the customer-supplied shunt field connections as shown in Figure 12 through Figure 15. The shunt field will be at 100VDC field voltage when the control is operated at 240VAC. The motor shunt field supply is rated at 1amp.

NOTE: TERMINALS F1 AND F2 ARE NOT USED WITH PERMANENT MAGNET MOTORS.

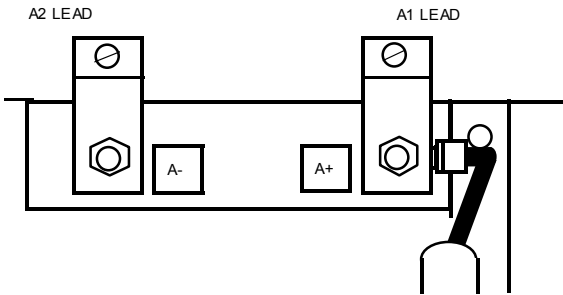
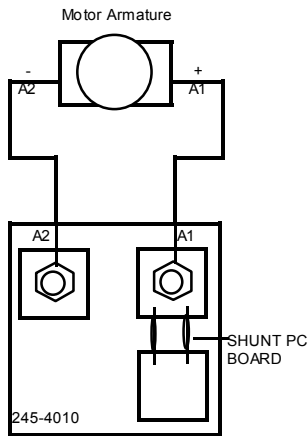
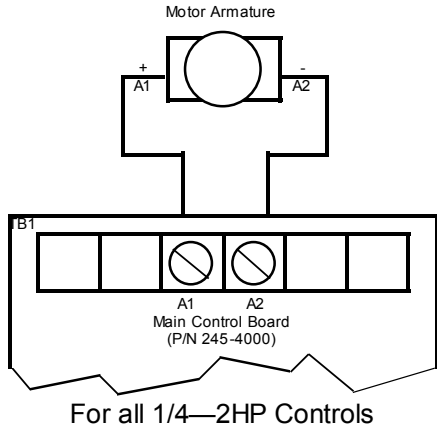

For 3—5HP Panel Mount Controls

Figure 6: Connection of Motor Leads to Enclosed, Less Operators, and Panel Mount Control

If the motor has a built-in thermal overload protection device, connect the thermal overload leads to TB2-1 and -2 on the main PC board.

CAUTION

IF MOTOR THERMAL OVERLOAD PROTECTION IS NOT DESIRED, TERMINALS 1 AND 2 OF TB2 MUST BE JUMPED TOGETHER, OR THE CONTROL WILL NOT OPERATE.

If, with the motor connected, the wrong rotational direction is observed, the rotational problem can be corrected in any of three (3) possible ways.

1. Exchanging the A1 and A2 output leads to the motor.
2. Exchanging the shunt field F1 and F2 leads on shunt wound motors only.
3. Changing the position of the Forward/Reverse switch, if this option kit is being used.

NOTE: EXCHANGING THE INCOMING POWER LEADS TO TERMINALS L1 AND L2 WILL NOT AFFECT THE DIRECTION OF MOTOR ROTATION.

4.8 PANEL MOUNT AND LESS OPERATORS CONTROL LOGIC AND SIGNAL WIRING

The Local On/Off, Run/Jog, and Start/Stop controls required for these drives are customer supplied. An uni-directional speed potentiometer is supplied loosely with the drive. Forward/Reverse operation can be accomplished through the use of the optional Magnetic Reverse Kit.

The On/Off switch is installed by the customer in the incoming L1-L2 line to the control. On less operators' controls, this switch can be installed on the enclosure cover.

The control circuitry allows the customer to wire the Run/Jog and Start/Stop logic with the supplied uni-directional potentiometer with or without a Forward/Reverse switch. The Run/Jog, Start/Stop, and potentiometer controls are wired into terminal block TB2, located along the left edge of the main PC board as shown in Figure 5. The basic Run/Jog, Start/Stop and potentiometer connections are shown in Figure 12 and Figure 13,. If Forward/Reverse recommended that shielded wire be used for reference, and other signal switch wiring is desired, refer to Figure 18 and Figure 19.

NOTE: IT IS RECOMMENDED THAT SHIELDED WIRE BE USED FOR REFERENCE, AND OTHER SIGNAL WIRE CONNECTIONS. BELDEN #83394 (2 CONDUCTOR) AND BELDEN #83395 (3 CONDUCTOR) SHIELDED WIRE (OR EQUIVALENT) IS RECOMMENDED. THE SHIELDS SHOULD BE TAPED OFF AT THE REMOTE END. AT THE DRIVE CONTROL, THE SHIELDS SHOULD BE CONNECTED TO CIRCUIT COMMON, TB-2 TERMINAL 11. ADDITIONAL CONSIDERATION IS RECOMMENDED TO ROUTE THIS WIRING AWAY FROM HIGH CURRENT LINES (I.E., AC LINES AND ARMATURE WIRING).

4.9 ENCLOSED CONTROL LOGIC AND SIGNAL WIRING

The local On/Off, Run/Jog, Start/Stop and speed potentiometer controls associated with enclosed drives are pre-installed on the enclosure cover. A Forward/Reverse switch, installable on the enclosure cover, is available as an option kit. The On/Off switch is wired into the 1FU and 2FU fuses located in the top cover half of the enclosure.

The Start/Stop and Run/Jog logic is pre-wired as shown in Figure 8. Terminal block TB2, shown in this figure, is located as shown in Figure 5. If a Forward/Reverse switch is desired, wire it as shown in Figure 22 and Figure 23.

4.10 INSTALLING MODIFICATIONS

When modifications are shipped loose as kits for field installation, each kit is individually packaged, identified, and includes all mounting hardware, wire, terminals, cable ties, labels and instructions. Figure 16 through Figure 23 can be used as a guide in connecting these kits to the control. Refer to paragraph 3.8 for a listing of the modification kits.

SECTION 5 OPERATION AND START-UP PROCEDURE

5.1 INTRODUCTION

This section describes the start-up procedure for the control and the adjustment of potentiometers that may be necessary for the application.

Read this section thoroughly to develop an understanding of the operation and logic incorporated into the control.

5.2 START-UP PROCEDURE

To insure maximum efficiency with a minimum amount of delay in production, factory start-up assistance by a factory engineer is available. Contact the factory to make arrangements.

CAUTION

THE FOLLOWING START-UP INSTRUCTIONS ARE INTENDED ONLY AS A GUIDE AND SHOULD BE CLEARLY UNDERSTOOD BY THE RESPONSIBLE INSTALLATION PERSONNEL BEFORE PROCEEDING.

5.2.1 PRE-START EQUIPMENT CHECKS

Before starting the control, all of the following pre-start conditions must be met.

1. Insure that the ¼ - 2HP controls have been properly programmed for 120VAC or 240VAC operation as described in paragraph 4.3.1.
2. Check that all the jumpers have been set correctly as in paragraph 4.3.
3. Complete all the wiring procedures as described in paragraphs 4.7, 4.8, and 4.9.

After all of the above pre-start conditions have been satisfied, proceed to the start-up procedure described as follows. This start-up procedure is equally applicable for the panel mount, less operators and enclosed controls.

5.2.2 OPERATION AND ADJUSTMENT

1. Turn the speed potentiometer extreme counterclockwise. Insure that the remote disconnect is admitting AC power to the control.
2. Set the On/Off switch (if used) to the ON position. This will apply power to the control but it will not start the motor. The DC POWER LED indicator light on the main control board will be off.
3. For initial start-up, set the Run/Jog switch (if used) to the RUN position. If the process requires a jog operation, disconnect the motor shaft from the load.
4. Set the Start/Stop switch to the START position to start the motor. The green DC POWER LED indicator light will illuminate.

NOTE: ON THE ENCLOSURE MOUNT CONTROLS, THE PROVIDED START/STOP SWITCH WILL SPRING BACK TO A MIDDLE POSITION AFTER IT HAS BEEN PLACED IN THE START POSITION AND RELEASED. THIS SWITCH *MUST* BE MOMENTARILY HELD IN THE START POSITION TO START THE MOTOR.

Adjust the speed potentiometer slowly clockwise until rotation begins. If the motor rotates in the wrong direction, simply place the Start/Stop switch in the OFF position, lock out power at the remote disconnect and exchange the A1 and A2 output leads to the motor. On shunt wound motors, exchange the shunt field F1 and F2 leads.

CAUTION

IF BACKWARD ROTATION OF THE MOTOR COULD DAMAGE THE DRIVEN MACHINE, THEN DIRECTION OF MOTOR ROTATION SHOULD BE DETERMINED BEFORE CONNECTING THE MOTOR SHAFT TO THE LOAD.

If the drive trips off, the motor will coast to a stop or fail to start. A drive trip off is usually caused by incorrect wiring. It also can be caused by either (1) a faulty motor or (2) a malfunctioning drive. Proceed to Basic Troubleshooting (paragraph 7.4).

5. With the motor rotating, adjust the operator speed potentiometer up and down. Changing the potentiometer setting (reference) results in a motor RPM change when operating in the RUN or JOG mode. Check that the motor follows this speed reference.

When the unit is used as a torque control, the potentiometer sets the motor torque level, and the motor accelerates or decelerates until the load torque equals the torque setting.

6. At this point place the Run/Jog switch in the JOG position if jog operation is desired. Connect the motor shaft to the load. In this position, the motor operates only when the Start/Stop switch is held in the START position.

7. The control can be stopped in one of two (2) ways as follows.

- a. A coast stop is initiated by either placing the Start/Stop switch in the STOP position or by removing the AC power at the local On/Off switch or at the remote disconnect. Once AC power is removed and then restored, the Start/Stop switch must be momentarily set to the START position to restart the motor.

b. A faster coast stop can be accomplished by installing the Dynamic Braking Kit. The “M” Contactor Kit or Magnetic Reversing Kit is required in this application. Refer to Figure 16 and Figure 23 and the instruction sheets provided with the individual kits for installation information.

8. Five (5) customer adjustable potentiometers are located on the main PC board as shown in Figure 11. These potentiometers have been preset. However, for proper operation in some applications, minor readjustments may be necessary.

Before making final adjustments, allow the motor to warm up for at least 15 minutes. With the control driving a motor, so not exceed ten (10) degrees of potentiometer rotation per second. Clockwise adjustment will cause an increase in the adjustment parameter.

WARNING

DO NOT ALLOW THE ADJUSTING SCREW DRIVER TO TOUCH ANYTHING OTHER THAN THE POTENTIOMETER WHILE THE CONTROL IS OPERATIVE. USE ONLY AN INSULATED SCREWDRIVER TO MINIMIZE THE HAZARDS OF ELECTRIC SHOCK.

Steps A and B describe, respectively, the potentiometer adjustment procedure for operation in the speed or torque (current) mode of control.

A. ADJUSTMENT PROCEDURE FOR OPERATION IN THE SPEED MODE:

NOTE: IF THE VOLTAGE OR CURRENT SIGNAL FOLLOWER KIT IS BEING USED, PERFORM THESE ADJUSTMENTS WITH THE AUTO/MANUAL SWITCH IN THE MANUAL POSITION.

1. IR compensation Adjustment

- a. IR Compensation is provided to overcome the motor’s natural tendency to slow down as the load increases. If the motor slows down excessively as it is loaded, the potentiometer marked “IR COMP” should be adjusted clockwise.
- b. If the IR compensation is adjusted too far clockwise, the motor will begin to oscillate in speed or “hunt”. If this pulsing of speed occurs, adjust the IR Compensation counterclockwise until the motor speed stabilizes.
- c. If the control has AC or DC tachometer feedback, adjust the IR COMP potentiometer fully counterclockwise.

2. Maximum Speed Adjustment

- a. Run the motor with the load applied.

- b. Turn the speed potentiometer on the operator control panel fully clockwise.
- c. Adjust the potentiometer on the main PC Board marked “MAX” to set the maximum motor speed. This may be adjusted from approximately 70-120% of motor base speed. **DO NOT EXCEED THE MOTOR NAMEPLATE MAXIMUM SPEED RATING.**
- d. Using a hand held tachometer or by visually observing machine operation, adjust “MAX” to the desired maximum setting.

3. Minimum Speed Adjustment

- a. With motor still running and full load applied, turn the speed potentiometer on the operator control panel fully counterclockwise.
- b. Adjust the potentiometer on main PC board marked “MIN” to desired lowest motor speed setting. This adjustment may be set at 0—30% of the maximum speed setting.

4. Acceleration/Deceleration Time Adjustment

- a. The “ACCEL/DECEL” adjustment on the main PC board may be used to vary the motor acceleration and deceleration times linearly from 2 – 30 seconds. Turn the adjustment clockwise to increase the time.
- b. Note that the controlled deceleration time occurs when the speed potentiometer is turned down, but not when the start/stop switch is placed in the STOP position.

5. Current Limit Adjustment

- a. Current Limit is factory set at 100% of the range selected by jumper JP1 (Low/Medium/High).
- b. The “CURRENT LIM” potentiometer should be set to limit the motor armature current to 150% or less of the motor nameplate rating. This setting should represent the lowest level consistent with satisfactory operation.
- c. If the motor stalls or slows down under load, check the motor armature current using a DC ammeter.

Stalling at less than the motor nameplate armature current rating indicates that the current limit is set too low. Slowly rotate the potentiometer clockwise until the motor returns to the set speed, but do not exceed the motor rated armature current.

Stalling with more than the nameplate armature current flowing indicates that the motor is overloaded.

CAUTION

THE CURRENT LIMIT MAY BE SET AS HIGH AS 150% OF THE MOTOR ARMATURE CURRENT RATING FOR A MAXIMUM OF ONE (1) MINUTE. THE CURRENT SHOULD EXCEED THE MOTOR RATING ONLY DURING STARTING OR BRIEF OVERLOADS. REPEATED OR EXTENDED OVERLOADS WILL DAMAGE THE CONTROL AND/OR MOTOR.

- d. The yellow CURRENT LIMIT LED indicator light on the main PC Board will illuminate when the armature current reaches 95-100% of the current limit setting.

B. ADJUSTMENT PROCEDURE FOR OPERATION IN THE TORQUE (CURRENT) MODE

1. Turn the potentiometers on the main PC Board marked "IR Comp" and "MAX" fully counterclockwise. These pots serve no purpose in this mode.
2. Start motor and turn the main torque potentiometer on operator control panel fully counterclockwise.
3. Adjust the potentiometer on the main PC board marked "MIN" to a minimum torque level if desired.

4. The "CURRENT LIM" adjustment on the main PC board should be set at full clockwise position. It could be used to set the maximum torque (current) lever (with the main torque potentiometer on the operator control panel turned fully clockwise). This will over-ride the main torque (current) reference potentiometer.

5. The "ACCEL/DECEL" potentiometer adjusts how quickly the motor torque level changes as the main torque potentiometer is varied.

9. After Steps A or B above are completed, the potentiometer in the operator control panel may be used to adjust either:

- A. Motor speed from the minimum to maximum speed setting if control is in the speed regulation mode, or
- B. Motor torque level from the minimum torque setting to the maximum torque level for the current range selected if the control has been set up as a torque control.

10. If the control has been equipped with the optional Magnetic Reversing Kit, a "forward/reverse" selector switch is supplied which changes the direction of motor rotation.

NOTE: MOTOR MUST BE RESTARTED AFTER THE POSITION OF THE "FORWARD/REVERSE" SWITCH IS CHANGED.

Flip this switch to verify that the motor follows direction change commands.

SECTION 6 FUNCTIONAL DESCRIPTION

This section describes, in detail, the following circuits included in the control:

1. Power Bridge and Field Supply
2. Run/Jog and Start/Stop Logic
3. Accel/Decel Circuit
4. Regulating Circuitry
5. Feedback Scaling Circuits
6. Current Limit Circuit
7. Firing Circuits
8. Power Supplies
9. Indicators

Throughout this section, reference to the schematic diagrams in Figure 24 and Figure 25 is recommended.

6.1 POWER BRIDGE AND FIELD SUPPLY

Throughout this paragraph, refer to Figure 7.

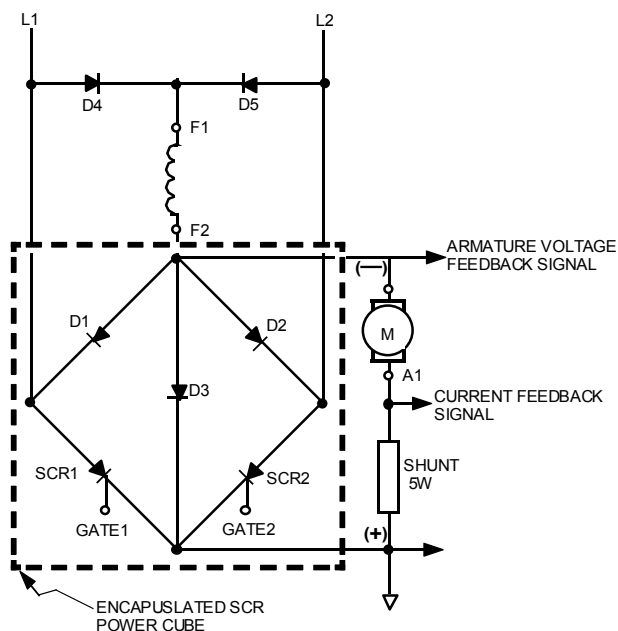

Figure 7: Power Bridge Assembly

The power bridge supplied in the control consists of an encapsulated SCR power cube containing two (2) SCRs and three (3) diodes. The basic operation consists of the following sequence.

When L1 is more positive with respect to L2, SCR1 is gated "on" at a particular phase angle commanded by the drive regulator circuitry. Current then flows from L1, through SCR1, the shunt resistor, the drive motor, diode D2, and back to L2. When L2 is more positive with respect to L1, SCR2 is gated "on". Current flows from L2, through SCR2, the shunt resistor, diode D1, and back to L1. This results in a positive current flow through the motor.

Diode D3 is called a "free wheeling" diode that insures continuity of the load current when the previously "fired" SCR becomes reverse biased. This diode also helps the SCR return to its blocking state.

Three functional details are shown in Figure 7.

1. Armature Voltage Feedback Signal – This signal is used in determining when the correct drive operating speed (voltage) is reached as required by the operator speed potentiometer.
2. Current Feedback Signal – This signal provides current information to the drive inner current loop.
3. Control Circuit Common – This is tied to the positive terminal of the power bridge.

NOTE: COMPONENT DESIGNATIONS IN Figure 7, SUCH AS "D1" AND "D2", ARE FOR REFERENCE PURPOSES ONLY. THEY DO NOT CORRESPOND TO ACTUAL COMPONENT DESIGNATIONS ON THE CONTROL.

CAUTION
THE CONTROL CIRCUIT COMMON IS FLOATING AND MUST NEVER BE TIED TO EARTH GROUND. ATTEMPTING THIS WILL CAUSE EQUIPMENT DAMAGE OR FAILURE.

Figure 7 also shows the motor shunt field supply. Diodes D1, D2, D4 and D5 form a single phase full wave uncontrolled rectifier bridge. This bridge produces a 200VDC field voltage when operated at 240VAC and 100VDC field voltage when operated at 120VAC. The motor shunt field supply rating is 1 amp.

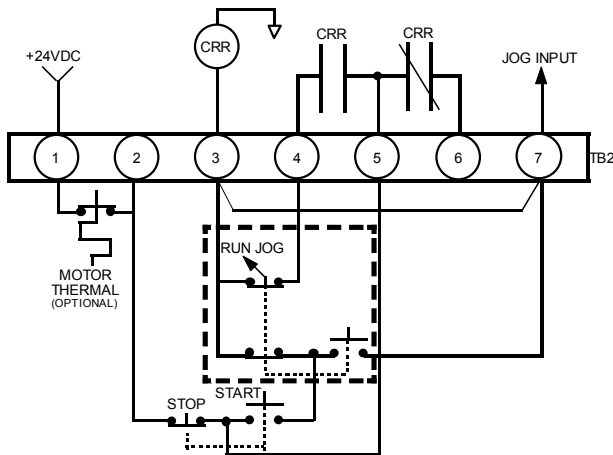

Figure 8: Power Bridge Assembly

6.2 RUN/JOG AND START/STOP LOGIC

When the Run/Jog and Start/Stop switches are pre-installed (such as in enclosed controls). Figure 8 shows the logic required to provide these functions.

The run sequence is as follows:

- A. Switch Start/Stop switch to START momentarily.
- B. CCR picks up and is sealed in through its normally open contacts.
- C. The accel/decel circuit, the regulator circuitry, and the speed pot reference supply are released.

When the stop PB is depressed, CRR is dropped out and all items mentioned in "C" above are clamped.

When "jog" (at run speed) is selected, the Start/Stop switch initiates the same sequence as detailed above (A,B & C) with the exception that CRR does not seal in and thus drops out when the Start/Stop switch is released.

6.3 ACCEL/DECCEL CIRCUIT

The accel/decel circuit accepts a 0 to +10 volt (1mA maximum) signal from either an isolated external voltage source or an internal +10 volt zener regulated supply, with operator's speed potentiometer connected as shown in Figure 15. This circuit is non-inverting, and has a single linear accel/decel time adjustment from 2 to 30 seconds. The output is then used as a reference to the control's velocity error amplifier. A clamp circuit is provided to clamp the output to zero whenever the drive is not in the run mode. Also note that the +10 volt speed potentiometer supply is only present in the run mode.

6.4 REGULATING CIRCUITRY

Throughout this paragraph, refer to Figure 9.

The multi-loop regulator circuitry consists of an inner current loop and an outer voltage (or speed) loop.

The current error amplifier is a proportional plus integral controller. The input to this amplifier is and error current. It is derived from the addition of a negative current reference (from the velocity error amplifier) and a positive feedback current (from the current scaling amplifier). This error current ramps the current error amplifier to a positive voltage. When feed to the firing circuits, this will enable the gated firing pulse generator at a phase angle that will provide the amount of current demanded by the velocity error amplifier. The remaining input to this amplifier is a positive signal that is only present in a stop condition. Its purpose is to clamp (or reset) the current amplifier whenever a stop command is given.

Then velocity error amplifier is also a proportional plus integral controller. It functions in the same manner as the current error amplifier, with this exception. Its error current is derived from the sum of a positive reference current (from the accel/decel circuit) and a negative feedback current (from either the armature or tach generator). The output of this amplifier is the negative current reference voltage. There are also two additional inputs to this amplifier. The first one is the IR compensation signal. This is a positive feedback signal and is derived from the current scaling amplifier. Its purpose is to compensate for the IR drop in the motor. This allows the motor to maintain a constant speed (within $\pm 1\%$ of base speed) from no load to full load. The second of these inputs is the jog input. This allows the drive to be stepped to jog speed (0-30% of maximum speed).

6.5 FEEDBACK SCALING

There are two scaling circuits, one for the voltage (or speed) feedback and one for the current feedback. The voltage scaling circuit is a passive network with three ranges: high, medium and low. This network also filters the voltage feedback.

The current feedback scaling network consists of an adjustable gain inverting amplifier. This circuit has three ranges.

The ranges mentioned above can be found in Table 2 and Table 3 of this manual.

6.6 CURRENT LIMIT CIRCUIT

Current limiting is achieved by limiting the current reference voltage. As shown in Figure 15, the output of the velocity error amplifier is divided by the current limit potentiometer whose wiper then feeds the current error amplifier. The divider ratio can be adjusted from 0 to 1 which will allow a 0 to 5.6 volt maximum current reference signal. A 5.6 volt value corresponds to 150% of control normal rating.

6.7 FIRING CIRCUITS

The firing circuits consist of three parts; 1) a timing ramp circuit, 2) a comparator circuit, and 3) a gated oscillator. The timing ramp is produced by allowing a capacitor to charge to 10 volts in 10mSec. This is reset to zero volts at every line zero crossing. This ramp voltage is then compared to the output voltage of the current error amplifier. When the ramp voltage exceeds the current error voltage, the comparator toggles to +15 volts DC and enables the gated oscillator. This oscillator will produce firing pulses 40 μ Sec wide and 800 μ Sec apart.

6.8 POWER SUPPLIES

For (4) power supplies are available. These supplies are ± 24 VDC and ± 15 VDC. The unit power supply transformer is jumper programmable on the main PC board for 240VAC or 120VAC and is rated at 6VA. These power supplies are not for customer use except for pre-engineered option kits.

6.9 INDICATORS

There are two indicators provided on the main control board. The first of these is the CURRENT LIMIT indicator. When this LED lights, it indicates that the drive has reached the current level as set by the current limit potentiometer. The second indicator provided is the DC POWER LED will be on any time gate pulses are present at the SCR gate terminals.

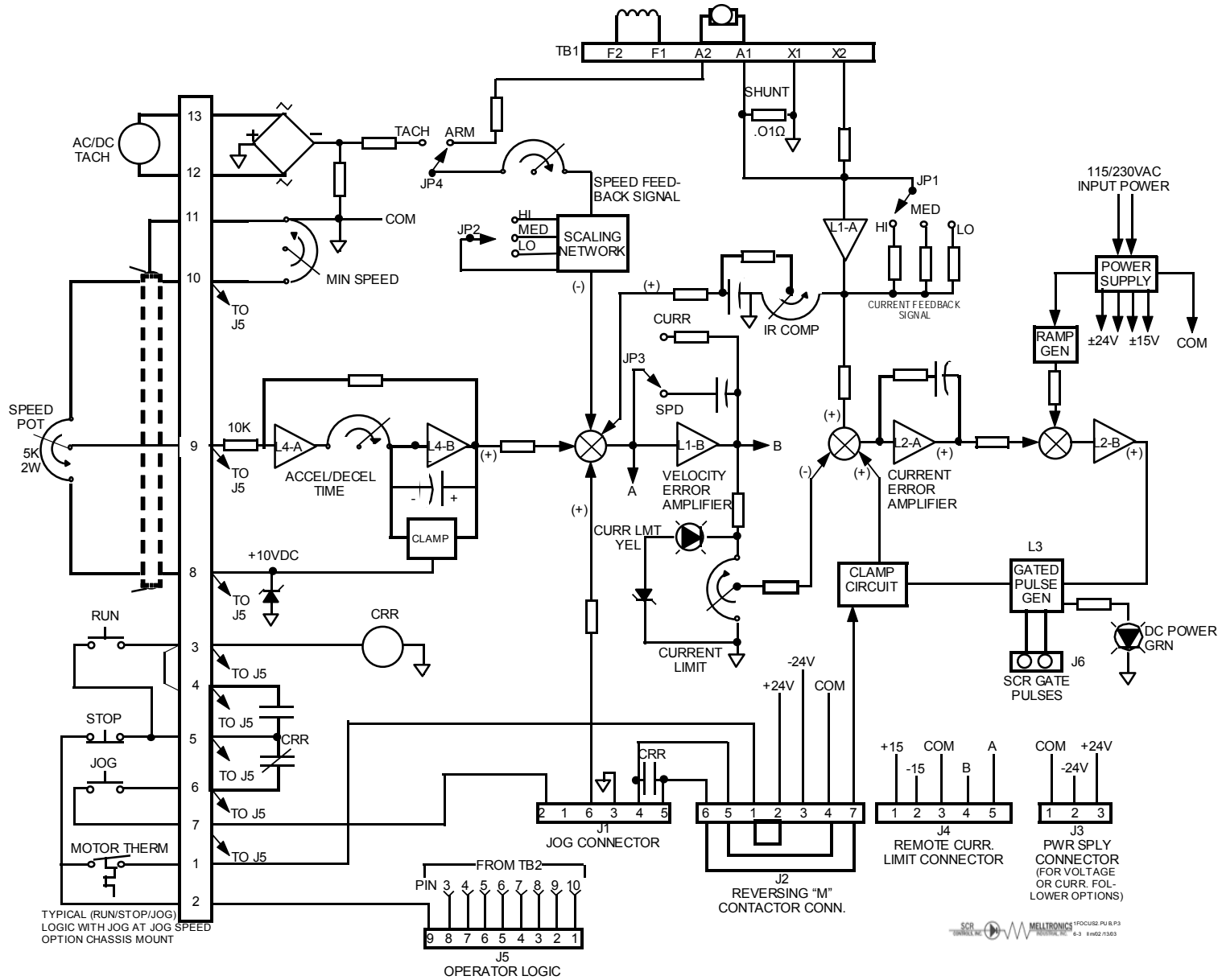

Figure 9: Control Circuit Block Diagram

SECTION 7 MAINTENANCE AND TROUBLESHOOTING

7.1 IMPORTANT SAFEGUARDS

Personnel familiar with it and its application should perform all work on the drive. Before performing any maintenance or troubleshooting, read the instructions and consult the system diagrams.

WARNING

MAKE SURE THAT ALL POWER SOURCES HAVE BEEN DISCONNECTED BEFORE MAKING CONNECTIONS OR TOUCHING INTERNAL PARTS. LETHAL VOLTAGES EXIST INSIDE THE CONTROL ANYTIME INPUT POWER IS APPLIED, EVEN IF THE DRIVE IS IN A STOP MODE. A TURNING MOTOR GENERATES VOLTAGE IN THE DRIVE EVEN IF THE AC LINE IS DISCONNECTED. EXERCISE CAUTION WHEN MAKING ADJUSTMENTS. WITH THE CONTROL DRIVING A MOTOR, DO NOT EXCEED TEN (10) DEGREES OF POTENTIOMETER ROTATION PER SECOND. NEVER INSTALL OR REMOVE ANY PC BOARD WITH POWER APPLIED TO THE CONTROL.

7.2 ROUTINE MAINTENANCE

Only minor adjustments should be necessary on initial start-up, depending on the application. In addition, some common sense maintenance needs to be followed.

- **KEEP IT CLEAN:** The control should be kept free of dust, dirt, oil, caustic atmosphere and excessive moisture.
- **KEEP IT COOL:** The control should be located away from machines having a high ambient temperature. On panel mount controls, air flow across heatsinks must not be restricted by other equipment within the enclosure.
- **KEEP CONNECTIONS TIGHT:** The equipment should be kept away from high vibration areas that could loosen connections or cause chafing of wires. All interconnections should be re-tightened at time of initial start-up and at least every six months.

WARNING

THE DC MOTOR MAY BE AT LINE VOLTAGE EVEN WHEN IT IS NOT IN OPERATION. THEREFORE, NEVER ATTEMPT TO INSPECT, TOUCH OR REMOVE ANY INTERNAL PART OF THE DC MOTOR (SUCH AS THE BRUSHES) WITHOUT FIRST MAKING SURE THAT ALL AC POWER TO THE CONTROL AS WELL AS THE DC POWER TO THE MOTOR HAS BEEN DISCONNECTED.

The motor should be inspected at regular intervals and the following checks must be made:

- A. See that both the inside and outside of the motor are not excessively dirty. This can cause added motor heating, and therefore can shorten motor life.
- B. If a motor blower is used, make sure that the air passages are clean and the impeller is free to rotate. If air filters are used, they should be cleaned at regular intervals or replaced if they are disposable. Any reduction in cooling air will increase motor heating.
- C. Inspect the commutator and brushes. Replace the brushes if needed. Make sure that the proper brush grade is used.
- D. The motor bearing should be greased per the manufacture's instructions as to type of grease and maintenance frequency. Over greasing can cause excessive bearing heating and failure. Consult the instructions supplied with the motor for more details.

7.3 TROUBLESHOOTING OVERVIEW

Fast and effective troubleshooting requires well-trained personnel supplied with the necessary test instruments as well as a sufficient stock of recommended spare parts. Capable electronic technicians who have received training in the control operation and who are familiar with the application are well qualified to service this equipment.

7.3.1 SUGGESTED TRAINING

- A. Study the system instruction manual and control drawings.
- B. Obtain practical experience during the system installation and in future servicing.
- C. Train in the use of test instruments.

7.3.2 MAINTENANCE RECORDS

It is strongly recommended that the user keeps records of downtime, symptoms, results of various checks, meter readings, etc. Such records will often help a service engineer locate the problem in the minimum time, should such services be required.

7.3.3 GENERAL TROUBLESHOOTING

The most frequent causes of drive failure are :

- A. Interconnect wires discontinuity, caused by a broken wire or loose connection.
- B. Circuit grounding within the interconnections or the power wiring.
- C. Mechanical failure at the motor.

DO NOT make adjustments or replace components before checking all wiring. Also monitor all LED indicator lights before proceeding with troubleshooting checks, and check for blown fuses.

It should be noted that modern solid-state electronic circuitry is highly reliable. **Often problems, which appear to be electrical, are actually mechanical. It is advised that the motor be checked in the event of any drive problems.** Refer to the motor owner's manual for maintenance and repair procedures.

7.3.4 NOTES FOR A TROUBLESHOOTING TECHNICIAN

A minimum knowledge of system operation is required, but it is necessary to be able to read the system schematics and connections diagrams.

An oscilloscope (Tektronix 214 or equivalent) may be needed to locate problem areas and to make adjustments. However, the majority of problems can be solved by using a multimeter and by parts substitution.

Multimeters having a sensitivity of 100 ohms per volt on DC or more are recommended, such as a Triplett Model 630, a Simpson Model 260, or equivalent.

WARNING

WHEN A TEST INSTRUMENT IS BEING USED, CARE MUST BE TAKEN TO INSURE THAT ITS CHASSIS IS NOT GROUNDED EITHER BY A GROUNDING PLUG CONNECTION OR BY ITS CASE BEING IN CONTACT WITH A GROUNDED SURFACE. EXTREME CARE MUST BE TAKEN WHEN USING THE OSCILLOSCOPE SINCE ITS CHASSIS WILL BE ELECTRICALLY HOT TO GROUND WHEN CONNECTED TO THE CONTROL SYSTEM.

7.4 BASIC TROUBLESHOOTING

This paragraph contains a basic list of symptoms of an improperly functioning control. Included in the list are possible causes and corrective measures for each symptom described.

WARNING

BEFORE PROCEEDING WITH ANY MAINTENANCE OR TROUBLESHOOTING ACTIVITY, ALL POWER SOURCES MUST BE DISCONNECTED AS DESCRIBED IN PARAGRAPH 7.1.

7.4.1 CONTROL APPEARS TO BE DEAD

Terminals TB-1 and -2 on the main PC board not jumpered together – install either a jumper or a motor thermal between these terminals.

No AC power – apply AC power.

Blown line fuses – replace line fuses.

Loose connections- turn off AC power and tighten connections.

Control incorrectly wired – recheck all wiring.

Defective Start/Stop switch, component on main PC board, or rectifier cube – replace bad components as required.

Speed potentiometer set to zero – slowly advance from zero to begin motor rotation.

7.4.2 LINE FUSES BLOW OR MAIN CIRCUIT BREAKER TRIPS WHEN APPLYING AC POWER

A. Control is wired to AC voltage exceeding control rating – require control to proper AC voltage or use step-down transformer.

B. Rectifier cube, field diodes on main PC board, motor winding or suppressor network shorted, or a short to ground is present – locate and remove short.

C. Improper wiring or jumper programming during installation – refer to SECTION 4 of this manual.

D. Defective main PC board component – replace as required.

E. Motor shaft jammed – determine cause and correct.

F. Excessive carbon dust from brushes in motor – determine cause and correct.

7.4.3 FUSES BLOW WHEN SPEED POTENTIOMETER IS ADVANCED FROM ZERO

A. Motor is overloaded – reduce load as required.

B. Motor is defective – consult motor instruction manual and repair or replace motor as required.

C. Current limit adjustment is set too high – readjust as described in Paragraph 5.2.2.

7.4.4 ACCEL/DECCEL RAMP IS MUCH LONGER THAN EXPECTED

A. Motor overloaded/overhauling – reduce load or apply optional braking kit.

7.4.5 MOTOR DOES NOT REACH FULL SPEED

Motor is overloaded – correct overload condition.
 Maximum Speed potentiometer (MAX) is set too low – adjust MAX potentiometer clockwise.
 Low AC line voltage (more than 10% below nominal) – check AC line voltage and correct.
 Current limit set too low – readjust as described in Paragraph 5.2.2.
 Incorrect jumper programming – follow programming procedure described in Paragraph 14.
 Defective rectifier cube – replace as required.
 Motor brushes worn – replace as specified in motor instruction manual.

7.4.6 MOTOR RUNS IN WRONG DIRECTION

The A1 and A2 output leads to the motor are incorrectly wired – exchange these leads.
 On shunt wound motors only the shunt field F1 and F2 leads are incorrectly wired – exchange these leads.
 The Forward/Reverse switch (if used) is in the wrong position – change this position.

7.4.7 MOTOR DOES NOT MAINTAIN SPEED UNDER LOAD

IR COMP potentiometer is set too low – adjust clockwise as described in Paragraph 5.2.2.
 Motor is overloaded – correct overload condition.
 Incorrect jumper programming – follow procedure described in Paragraph 4.3.
 Defective component on main PC board – replace as required.
 Current limit set too low – readjust as described in Paragraph 5.2.2.
 Motor brushes worn – replace as specified in motor instruction manual.

7.4.8 MOTOR IS UNSTABLE OR OSCILLATES

IR COMP potentiometer is set too high – adjust IR COMP potentiometer counterclockwise until the motor speed stabilizes without oscillating.
 Defective motor – consult motor instruction manual and repair or replace as required.
 Load is loosely coupled to motor or misaligned – check and correct load coupling
 Loose wire connections – tighten connections (to motor).
 Defective component on regulator PC board – replace as required.
 Motor overloaded/overhauling – decrease or increase load as required.
 Low AC line voltage (more than 10% below nominal) – check AC line voltage and correct.
 Incorrect jumper programming – follow procedure described in Paragraph 4.3.
 Current limit set too low – adjust as described in Paragraph 5.2.2..

7.4.9 MOTOR DOES NOT COME TO FULL STOP

Minimum Speed potentiometer (MIN) is set too high – readjust as described in Paragraph 5.2.2..
 Defective speed or torque potentiometer, component on regulator PC board, Start/Stop switch, or rectifier cube – replace as required.

7.4.10 YELLOW CURRENT LIMIT LED LIGHTS ON THE MAIN PC BOARD OF A 3-5 HP CONTROL

The A1 and A2 motor leads have been wired directly to TB1-A1 and A2 on the main PC board – remove these connections and re-wire as described in Paragraph 4.7.4.

7.4.11 NO SPEED CONTROL

Defective rectifier cube – replace as required.
 Defective component on main PC board – replace as required.
 Incorrectly wired or defective speed potentiometer – check the wiring procedure as described in SECTION 4 and SECTION 9 of this manual or replace as required.
 Incorrect jumper programming – check procedure described in Paragraph 4.3.
 If the control (after rechecking all the wiring for proper and secure connections) is still inoperative, make the following voltage checks. Double check to make sure that armature leads A1 and A2 are not grounded.

Table 4: Voltage Check Chart

STEP	FUNCTION	NORMAL READING	VOLTAGE READING	TERMINAL OR POINT	PROBABLE CAUSE
1 with on/off switch "on	Voltage to Rectifiers	120VAC ±10%	240VAC ±10%	AC1, AC2 On power cube	Defective switch or loose or broken wire to or from switch
2*	Speed Reference	0 to +10 VDC	0 to +10 VDC	9-11	Defective speed adjustment potentiometer or circuit board assembly
3	Field Supply	100 VDC	200 VDC	+F1 -F2	Defective field diodes defective encapsulated bridge rectifier assembly
4	Armature Voltage	0-90 VDC	0-180 VDC	+A1 -A2	Defective encapsulated bridge rectifier assembly or circuit board assembly

*Depends on the setting of the speed adjustment knob.

SECTION 8 ORDERING SPARE PARTS

Spare parts kit numbers 2400-9901, 2450-9901, and 2450-9902 provide, for most customers, all the spare parts ever required. These kits contain the following components:

COMPONENT	DESIGNATION	QUANTITY	PART NUMBER
Kit # 2450-9901 – for ¼- 2HP Panel Mount Controls:			
Power Cube, 230V		1	3720-004
Fuse, 15A	1FU, 2FU	6	3707-601500

Kit#2450-9902 – for all 3-5HP Controls:			
Power Cube, 230V		1	3720-010A
Fuse, 40A, 500V	1FU, 2FU	6	3707-504000

If a more sophisticated level of troubleshooting is required, see the following listed part numbers for reference.

ENCLOSED CONTROL (P/N 2450-8000W, 1/4-2HP) ASSEMBLY COMPONENTS

MOLDED UPPER/FRONT CHASSIS:			
Blue cover only		1	2450-5001
Label for cover		1	2450-5004
Cover gasket		1	2450-5019
Fuse, 15A, 250V	1FR, 2FU	2	37050-032
Power cube, 230V		1	3720-004
FACEPLATE ASSEMBLY:			
Switch, toggle	“ON/OFF”	1	3550-004
Switch, toggle	“RUN/JOG”	1	3550-003
Switch, toggle	“START/STOP”	1	3550-005
Potentiometer, 5K, 2W	“SPEED”	1	3533-0502
Speed pot push-on knob		1	3549-002
Switch boot		3	3555-001
Seal, pot shaft		1	3555-002
MOLDED LOWER/BACK CHASSIS:			
Blue molded chassis		1	2450-5000
PC BOARD ASSEMBLY:		1	2450-4000A

ENCLOSED CONTROL (P/N 2450-3001W, 3-5HP) ASSEMBLY COMPONENTS

MOLDED UPPER/FRONT CHASSIS:			
Blue cover only		1	2450-5001
Label for cover		1	2450-5007
Cover gasket		1	2450-5019
Fuse, 40A, 500V	1FU, 2FU	2	3701-504000
Power cube, 230V		1	3720-010A
FACEPLATE ASSEMBLY:			
Switch, toggle	"ON/OFF"	1	3550-006
Switch, toggle	"RUN/JOG"	1	3550-003
Switch, toggle	"START/STOP"	1	3550-005
Potentiometer, 5K, 2W	"SPEED"	1	3533-0502
Speed pot push-on knob		1	3549-002
Switch boot		2	3555-001
Seal, pot shaft		1	3555-002
MOLDED LOWER/BACK CHASSIS:			
Blue molded chassis		1	2450-5000
PC BOARD ASSEMBLY:			
Shunt Resistor Board		1	2450-4010
Resistor only, .005 ohm, 5W	R1, R2	2	0916-R005-005

LESS OPERATORS CONTROL (P/N 2450-8002W, ¼ - 2HP) ASSEMBLY COMPONENTS

MOLDED UPPER FRONT CHASSIS:			
Blue cover only		1	2450-5005
Label for cover		1	2450-5017
Cover gasket		1	2450-5019
Fuse, 15a, 250V	1FU, 2FU	2	3705-032
Power cube, 230V		1	3720-004
Potentiometer, 5K, 2W	"SPEED"	1	3533-0502
Speed pot push-on knob		1	3549-002
MOLDED LOWER/BACK CHASSIS:			
Blue molded chassis		1	2450-5000
PC BOARD ASSEMBLY:			
PC BOARD ASSEMBLY:		1	2450-4000A

LESS OPERATORS CONTROL (P/N 2450-8003W, 3-5HP) ASSEMBLY COMPONENTS

MOLDED UPPER/FRONT CHASSIS:

Blue cover only		1	2450-5005
Label for cover		1	2450-5018
Cover gasket		1	2450-5019
Fuse, 40a, 500v	1FU, 2FU	2	3701-504000
Power cube, 230V		1	3720-010a
Potentiometer, 5K, 2W	"SPEED"	1	3533-0502
Speed pot push-on knob		1	3549-002

MOLDED LOWER/BACK CHASSIS

Blue molded chassis		1	2450-5000
PC BOARD ASSEMBLY:		1	2450-4000A
Shunt Resistor PC Assembly		1	2450-4010
Resistor only, .005 ohm, 5W	R1, R2	2	0916-R005-005

PANEL MOUNT CONTROL (P/N 2450-8010W, ¼ - 2HP) ASSEMBLY COMPONENTS

Fuse 15A, 600V	1FU, 2FU	2	3707-601500
Power cube, 230V		1	3720-004
Potentiometer, 5K, 2W	"SPEED"	1	3533-0502
Speed pot push-on knob		1	3549-002
PC BOARD ASSEMBLY:			2450-4000A

PANEL MOUNT CONTROL (P/N 2450-8015W, 3 - 5HP) ASSEMBLY COMPONENTS

Fuse 40A, 500V	1FU, 2FU	2	3701-504000
Power cube, 230V		1	3720-010A
Potentiometer, 5K, 2W	"SPEED"	1	3533-0502
Speed pot push-on knob		1	3549-002
PC BOARD ASSEMBLY:			2450-4000A
Shunt Resistor PC Assembly		1	2450-6010
Resistor only, .005 ohm, 5W		2	0916-R005-005

This board is used on all control models. The part numbers on the components may differ from this parts list because ICD numbers in many cases has replaced vendor numbers.

MAIN PC BOARD (P/N 2450-4000A) COMPONENTS

CAPACITORS: Consult factory with the value and board designation.			
LED (green)	"DC POWER"	1	4030-310
LED (yellow)	"CURRENT LIM"	1	4030-410
DIODES, ZENER:			
I.C.'S			
	L1, 2, 4	3	4041-0358
POTENTIOMETERS:			
	"MIN", "CURRENT LIM", "IR COMP"	3	3545-053
	"MAX", "ACCEL/DECEL"	2	3545-254
RELAY:			
	CRR	1	3515-026
RESISTORS: Consult factory with value and board designation.			
TERMINAL BLOCKS:			
6-PIN	TB1	1	3792-1606
13-PIN	TB2	1	3792-1513
TRANSFORMER:	T1	1	3082-436
TRANSISTORS:			
	Q5	1	3970-001
	QVR1	1	4071-2515

SECTION 9 SUPPLEMENTARY TECHNICAL INFORMATION

Table 5: Control Standard Connection Scheme Terminal Blocks TB1 and TB2
Terminal blocks TB1 and TB2 are installed on the main PC board 2450-4000. This board is used on all six control models.

TB1	
F1, F2	Shunt field connections
A1, A2	DC Motor connections for ¼ - 2HP controls <i>only</i> . Do not wire directly to TB1-A1, and -A2 with 3-5HP controls.
X1, X2	For M-Contactor and Reversing Kit installations on 3-5 HP controls.
TB2	
1, 2	N.C. Motor thermal contact, (if required). If contact is not used , terminals 1 and 2 <i>must</i> be jumpered together.
2, 5	N.C. Stop contact
3, 4, 7	Run/Jog switch contacts on Enclosed controls. On Less Operators and Panel Mount models, terminals 3 and 4 become the Run/Jog contact, if used (or they are jumpered and become with terminal 5, the N.O.. Start contact if a Run/Jog switch is not used), and terminal 7 is not used.
6	Tied to N.C. contact of CRR relay
8	CW side of speed potentiometer
9	Wiper contact of speed potentiometer
10	CCW side of speed potentiometer (MIN Speed)
11	Shield connection for speed pot wiring
12, 13	AC/DC Tachometer connections

Table 6: Customer Jumper Programming Chart (filled out by customer)

JUMPER GROUP	POSITION AT START-UP
JA	
JB	
JP1	
JP2	
JP3	
JP4	

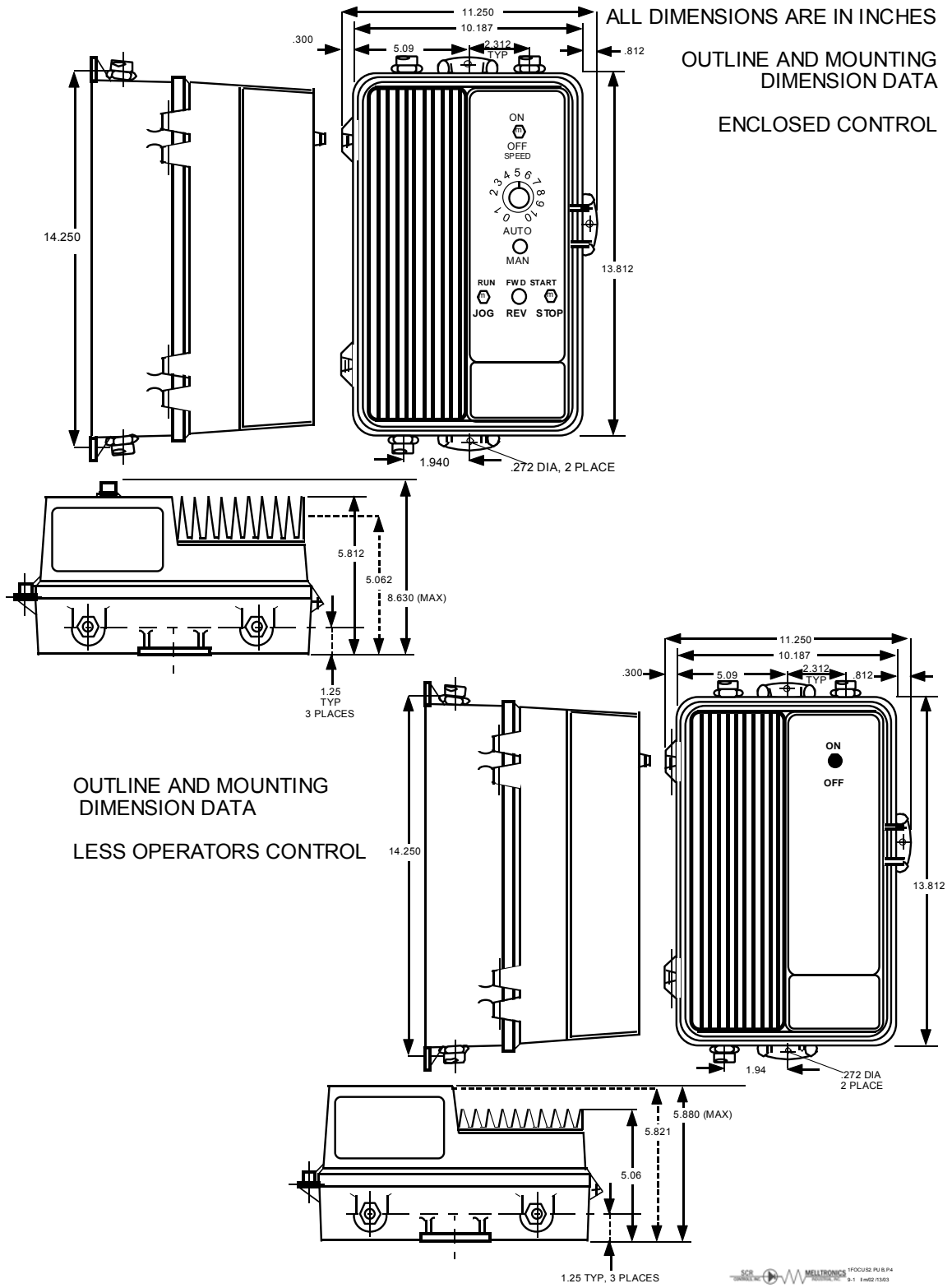
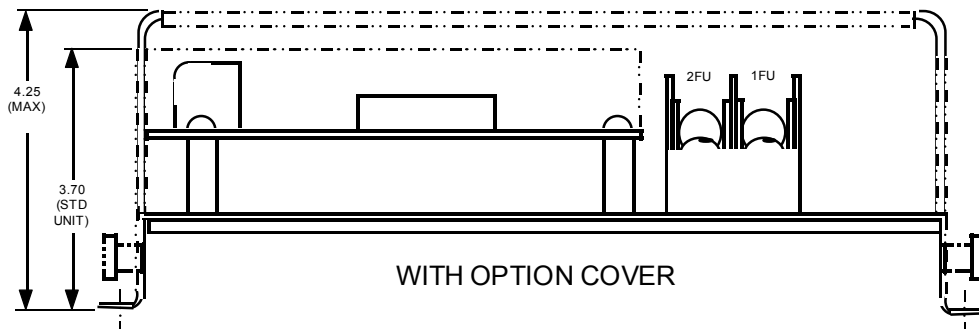
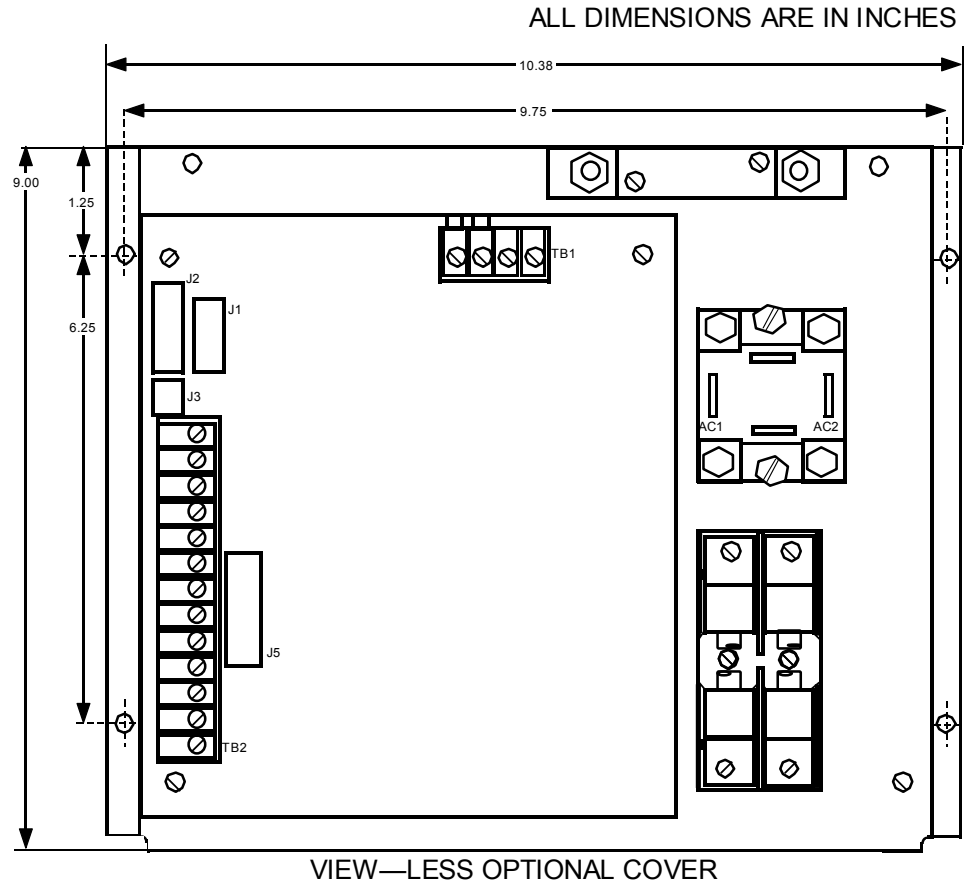

Figure 10: Outline and Mounting Dimensions for Panel Mount, Less Operators, and Enclosed Controls



OUTLINE AND MOUNTING
DIMENSIONS DATA

PANEL MOUNT CONTROL

Figure 11: Outline and Mounting Dimensions for Panel Mount, Less Operators, and Enclosed Controls

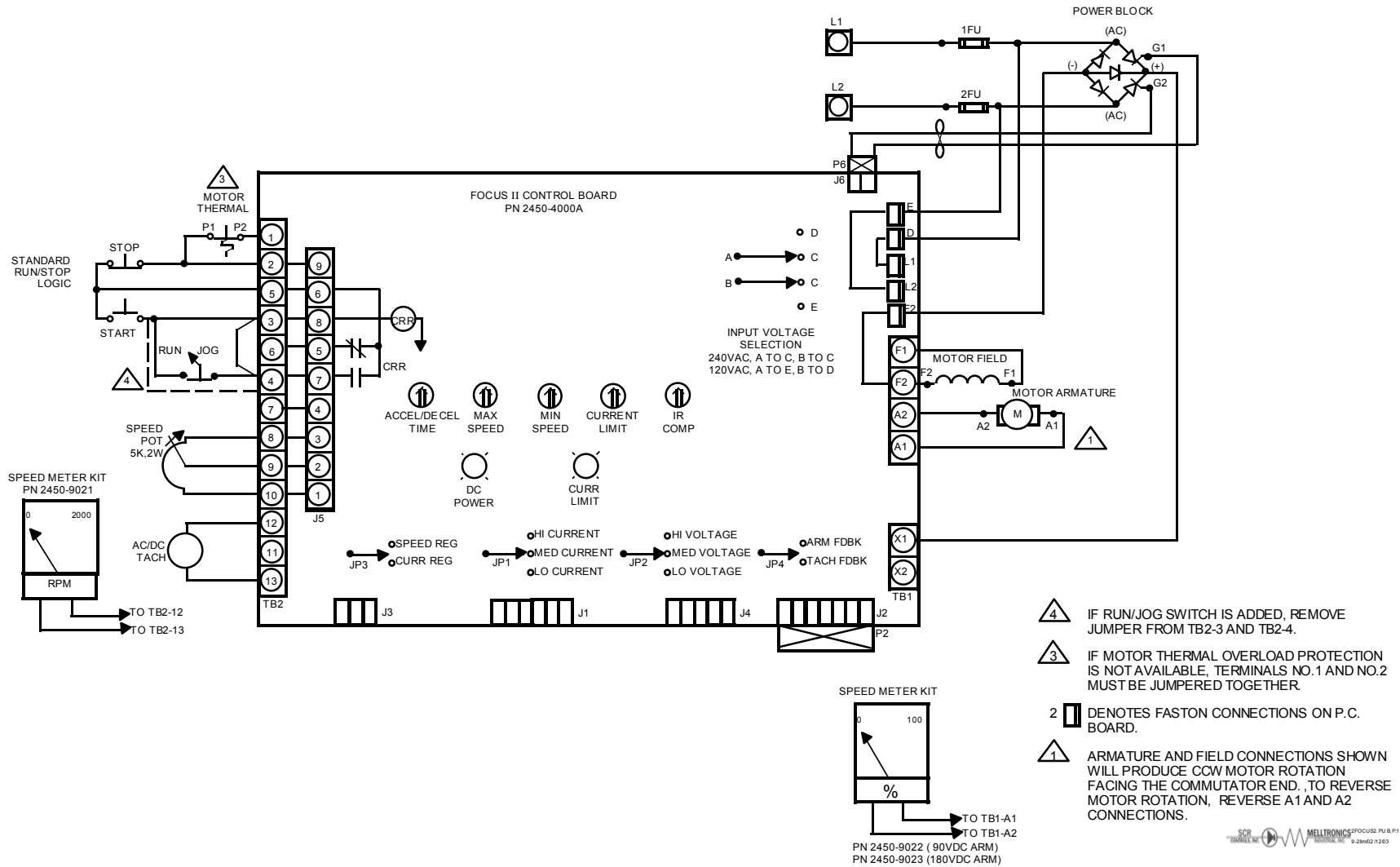

Figure 12: Connection Diagram for Low HP Panel Mount & Less Operators Controls, 2450-1100-I, Rev.A

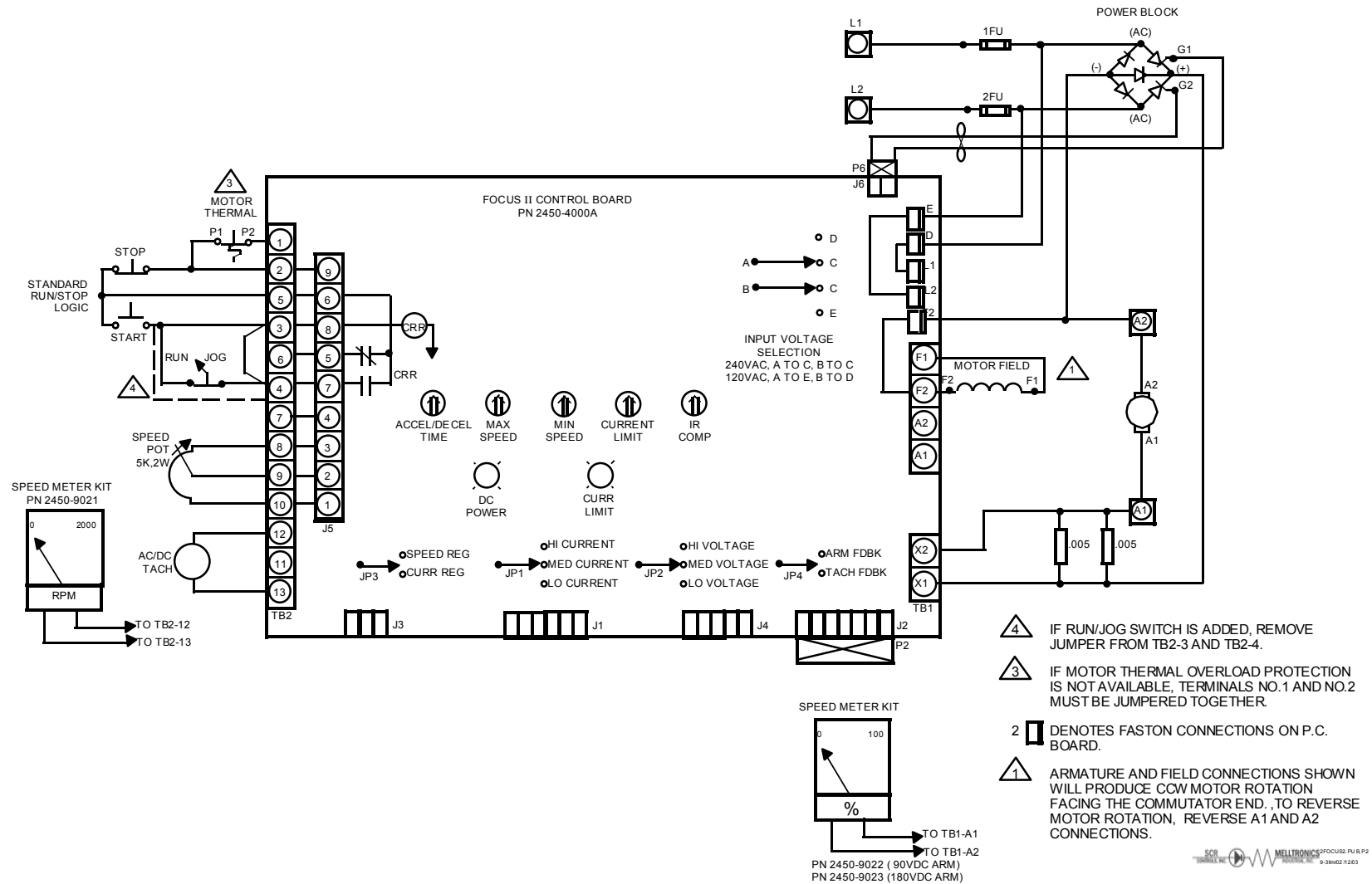

Figure 13: Connection Diagram for High HP Panel Mount & Less Operators Controls, 2450-1101-I, Rev. A

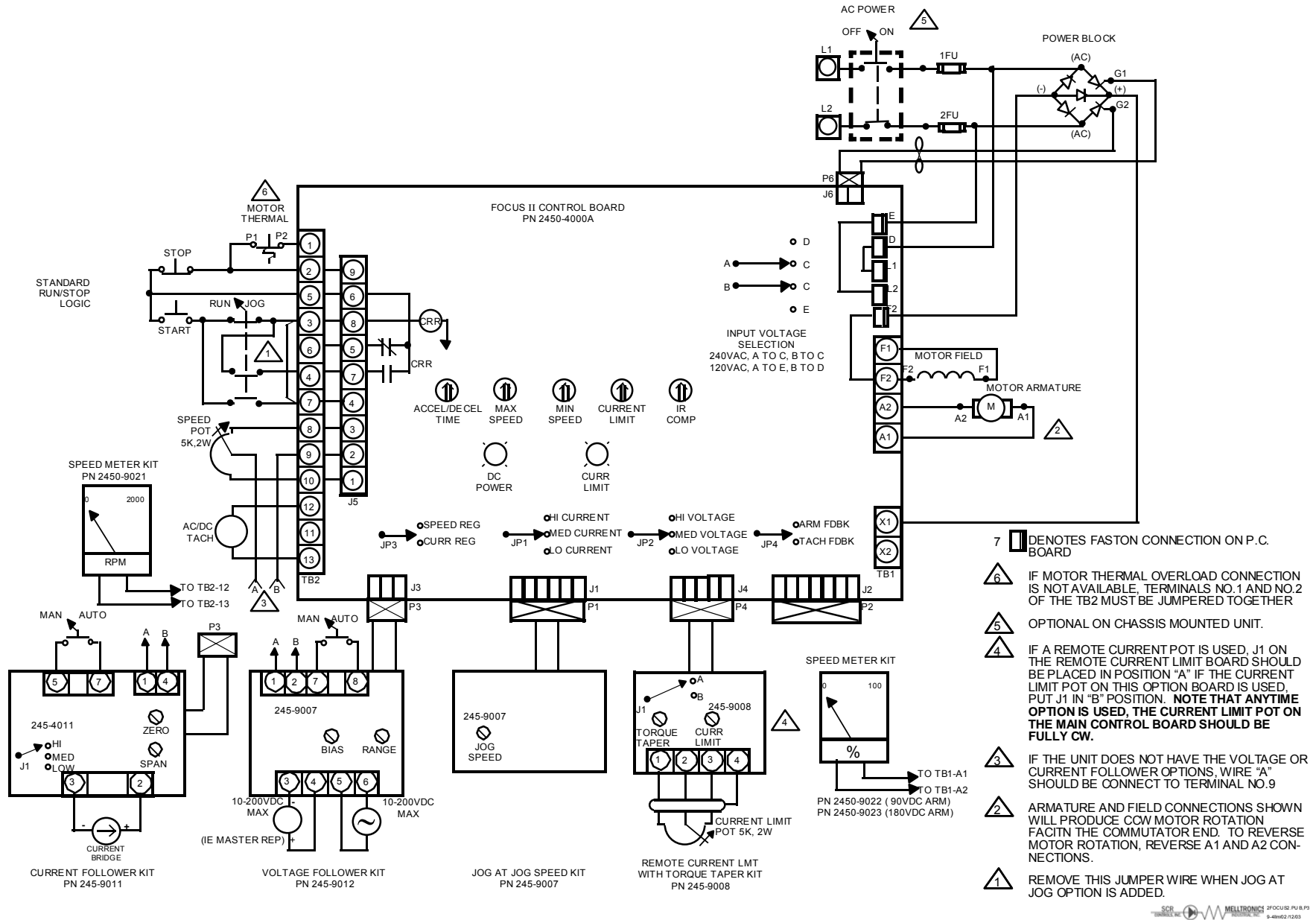

Figure 14: Connection Diagram for Low HP Enclosed Controls, 2450-1000-I, Rev. A

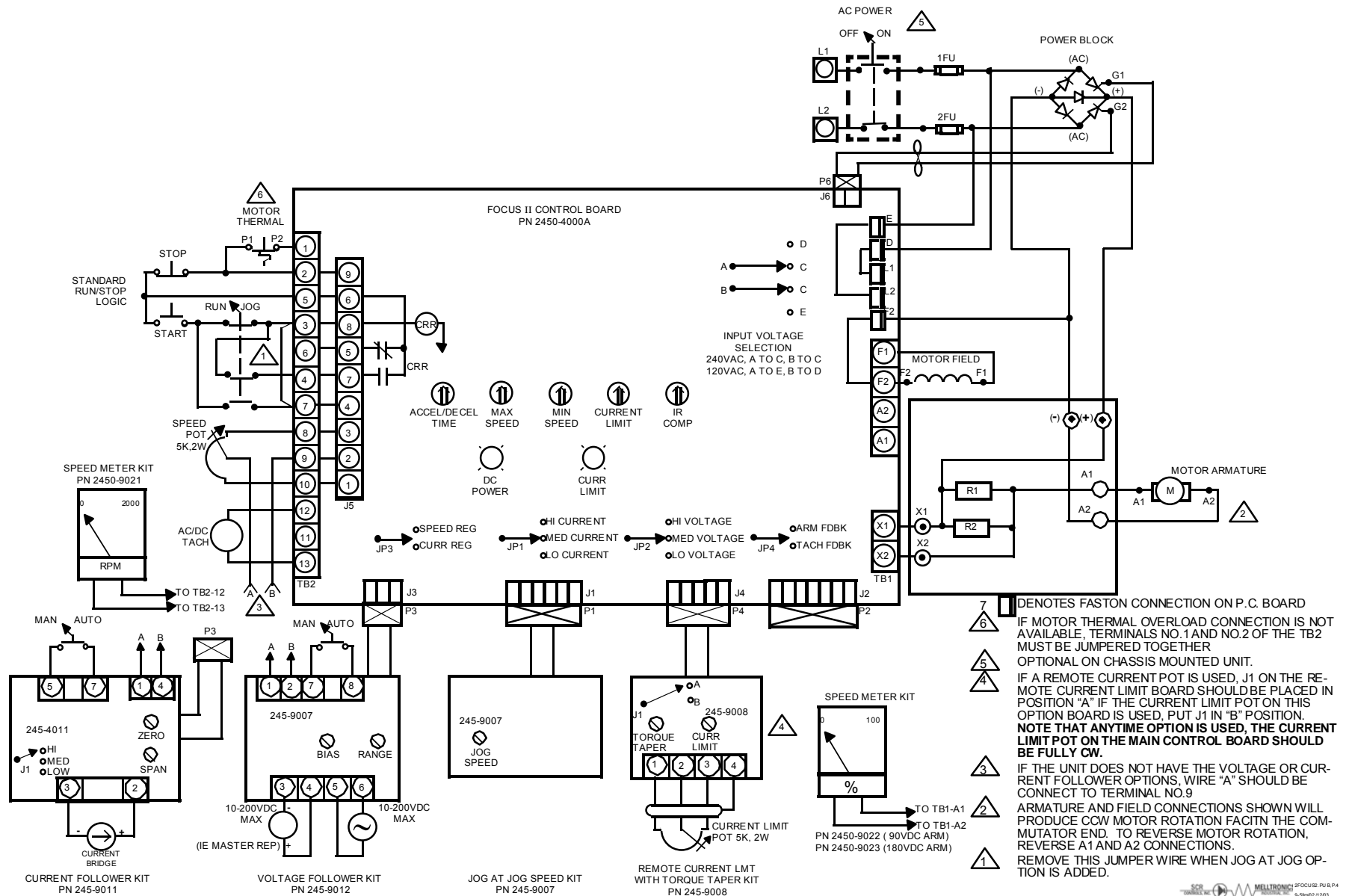

Figure 15: Connection Diagram for High HP Enclosed Controls, 2450-1001-I, Rev. A

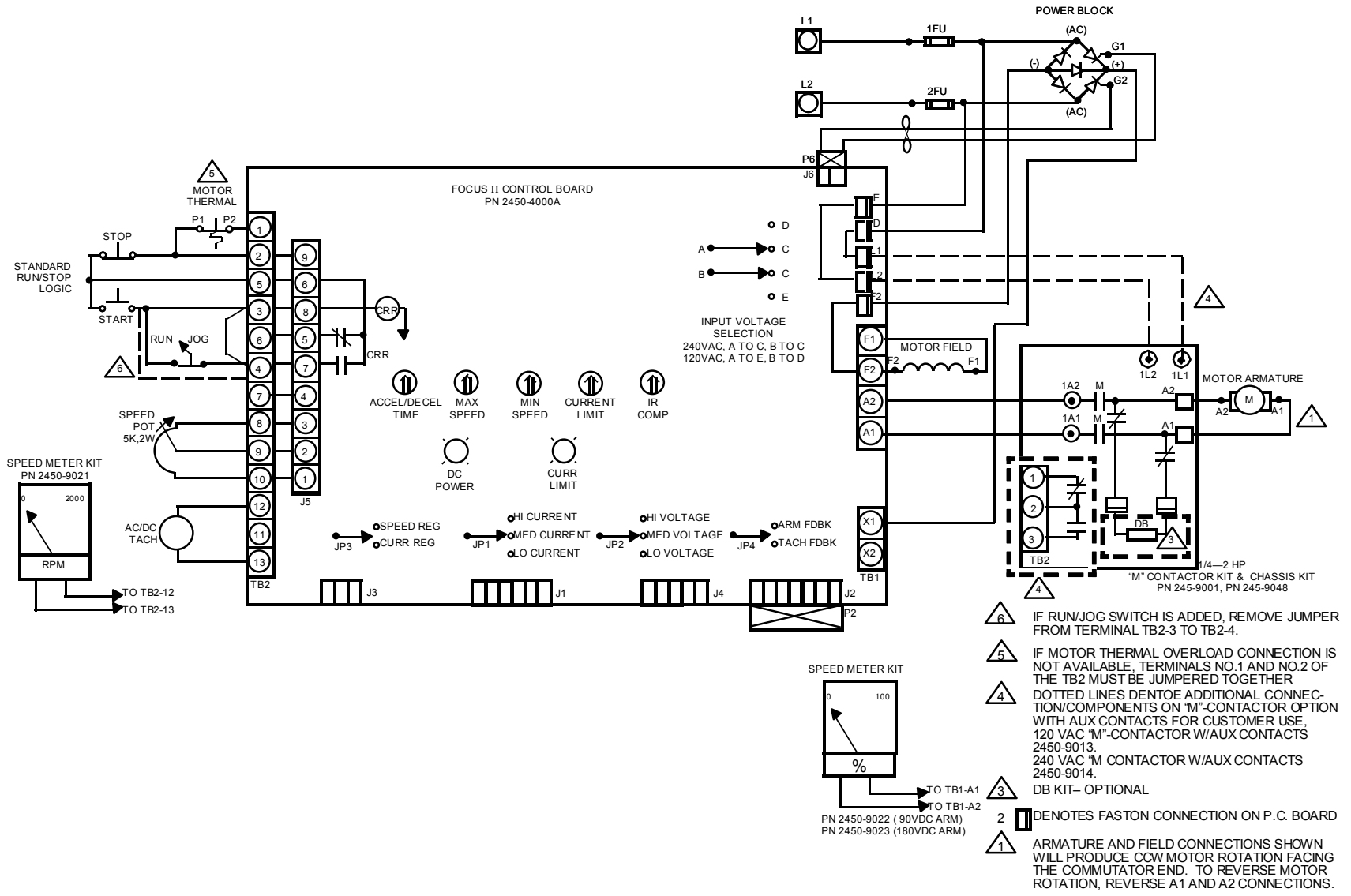

Figure 16: Panel Mount and Less Operators Low HP Controls with "M" Contactor, 2450-1102-I, Rev.A

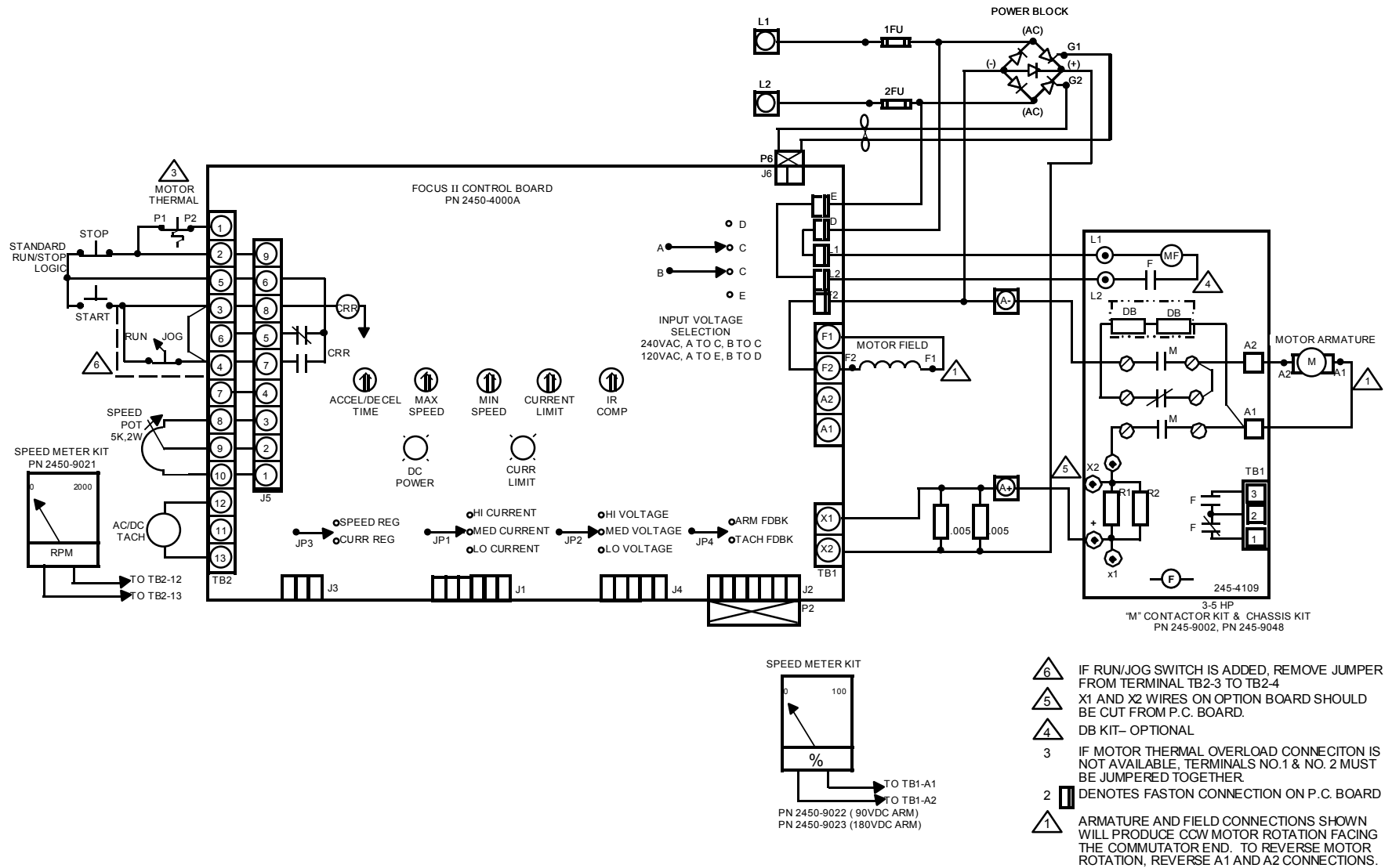

Figure 17: Panel Mount & Less Operators High HP Controls with "M" Contactor, 2450-1103-I, Rev.A

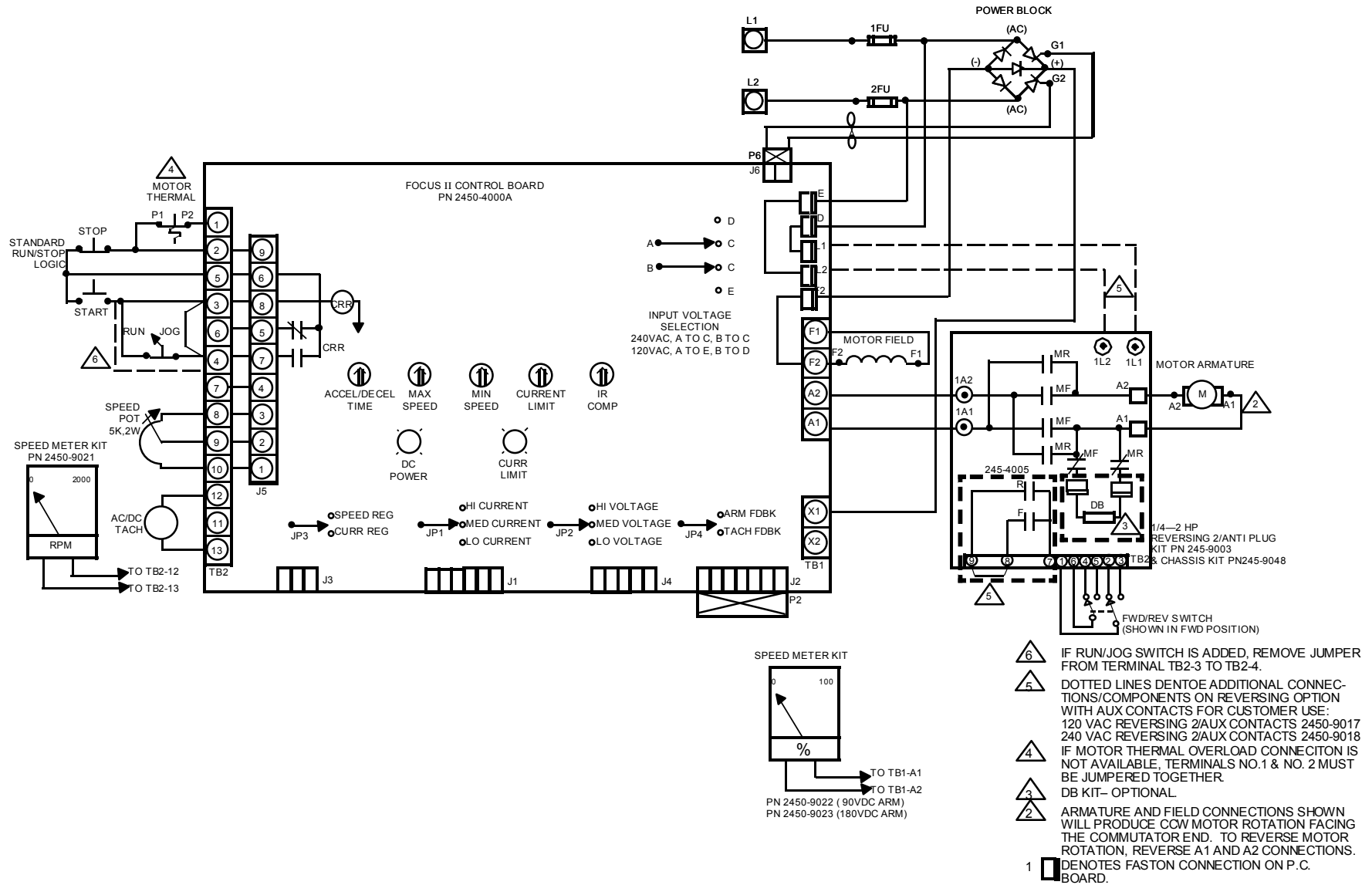

Figure 18: Panel Mount & Less Operators Low HP Controls with Reversing Kit, 2450-1104-I, Rev.A

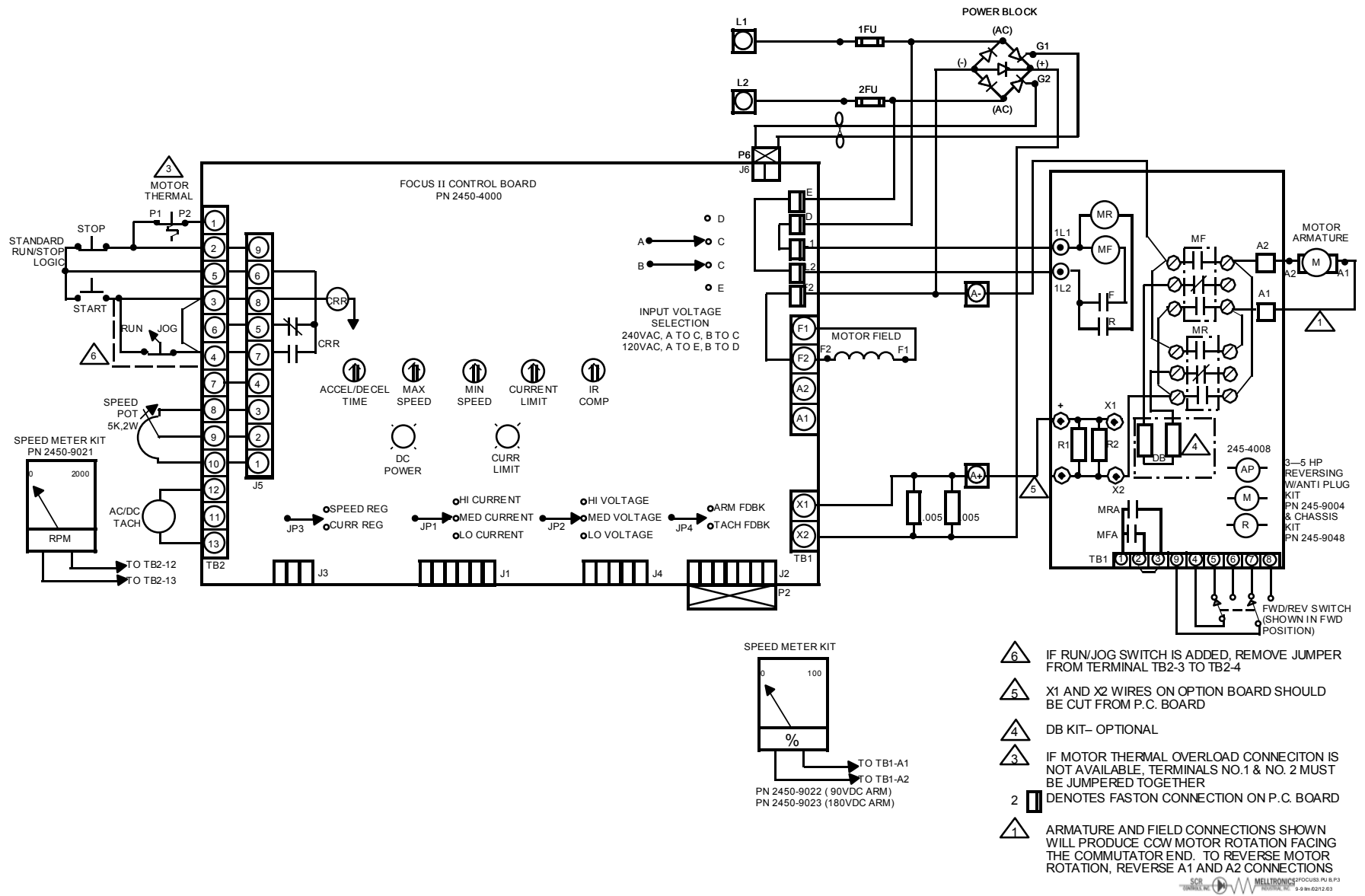

Figure 19: Panel Mount & Less Operators High HP Controls with Reversing Kit,2450-1105-I,Rev.A

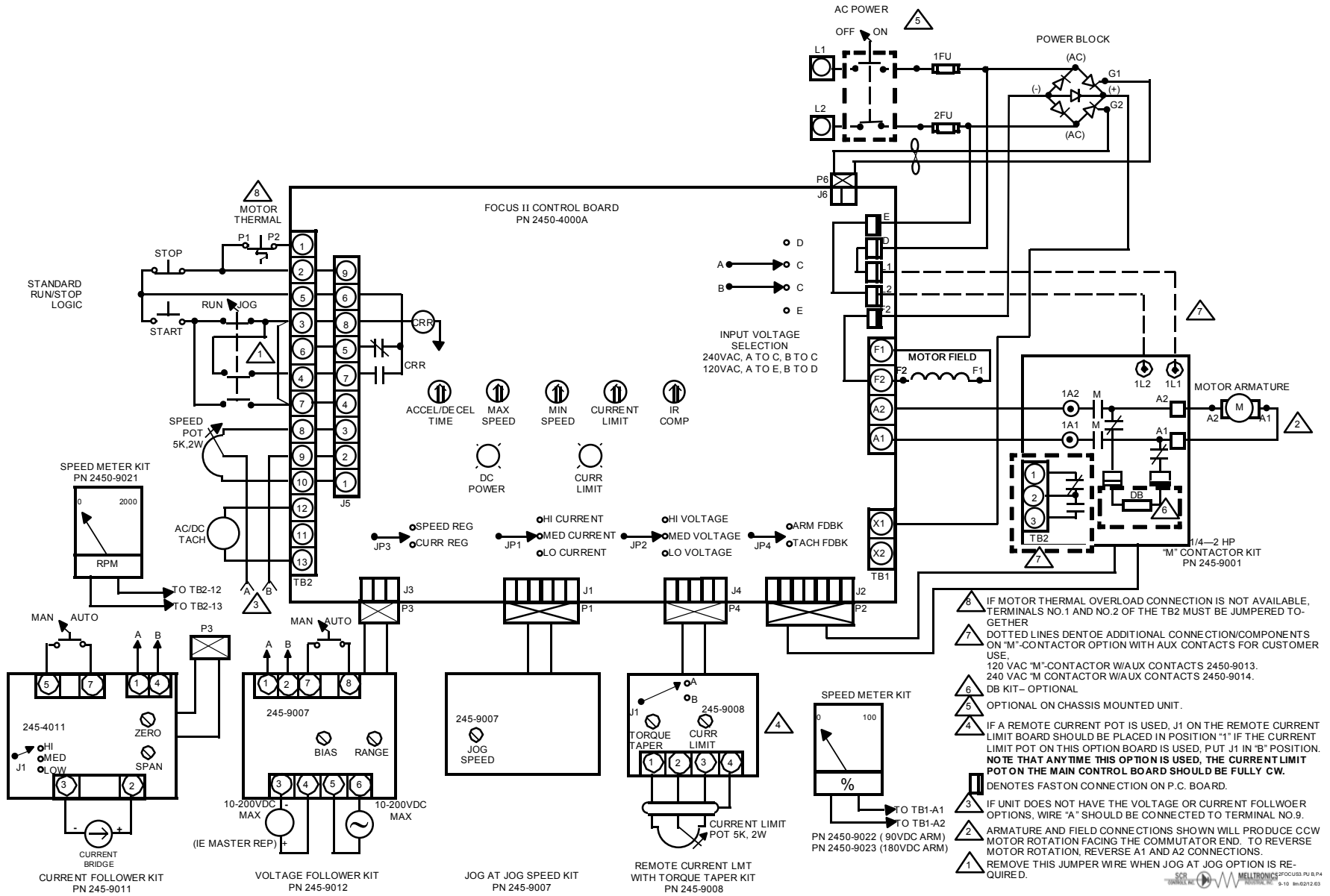

Figure 20: Enclosed Low HP Control with "M" Contactor, 2450-1002-I, Rev. A

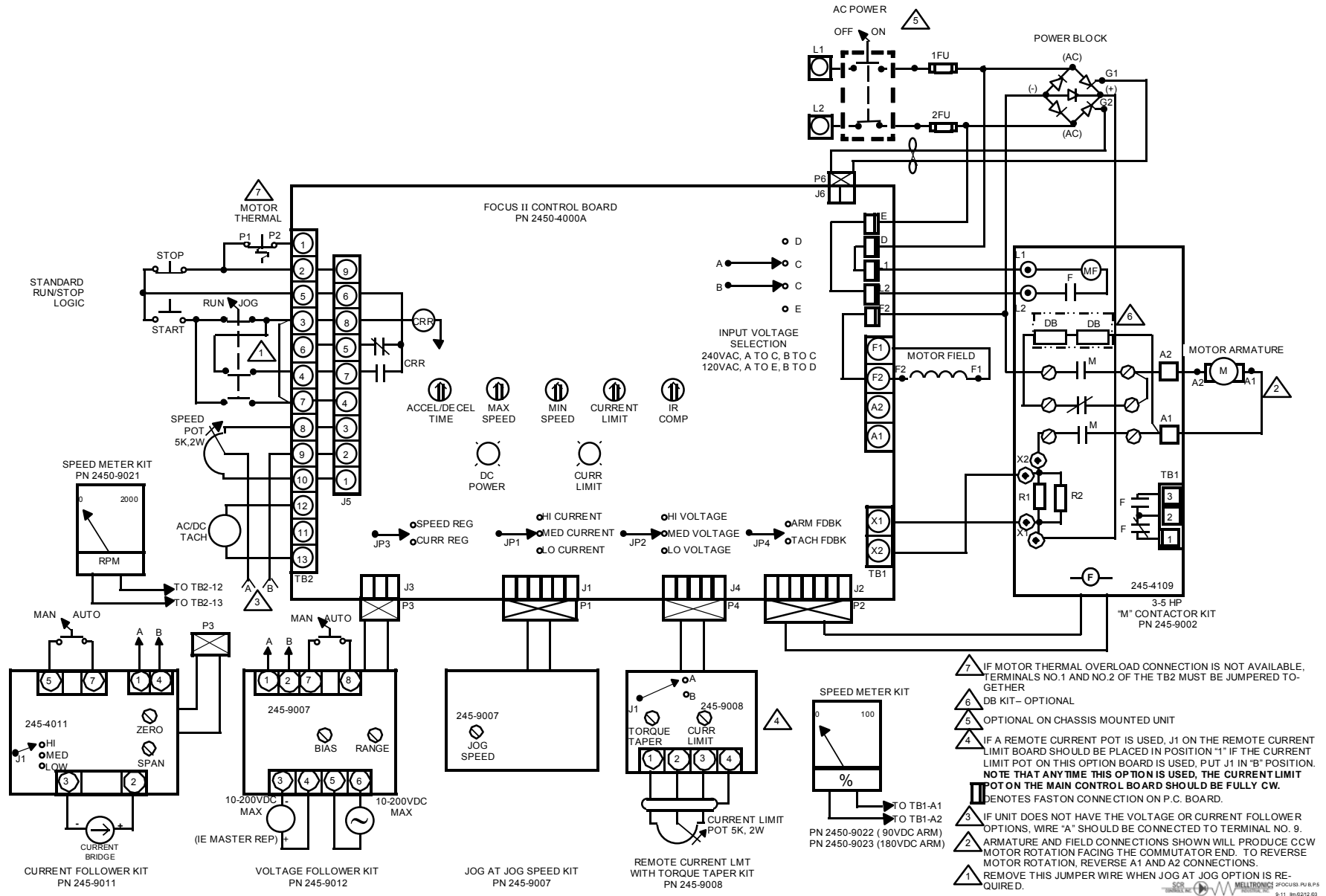

Figure 21: Enclosed High HP Control with "M" Contactor, 2450-1003-I, Rev. A

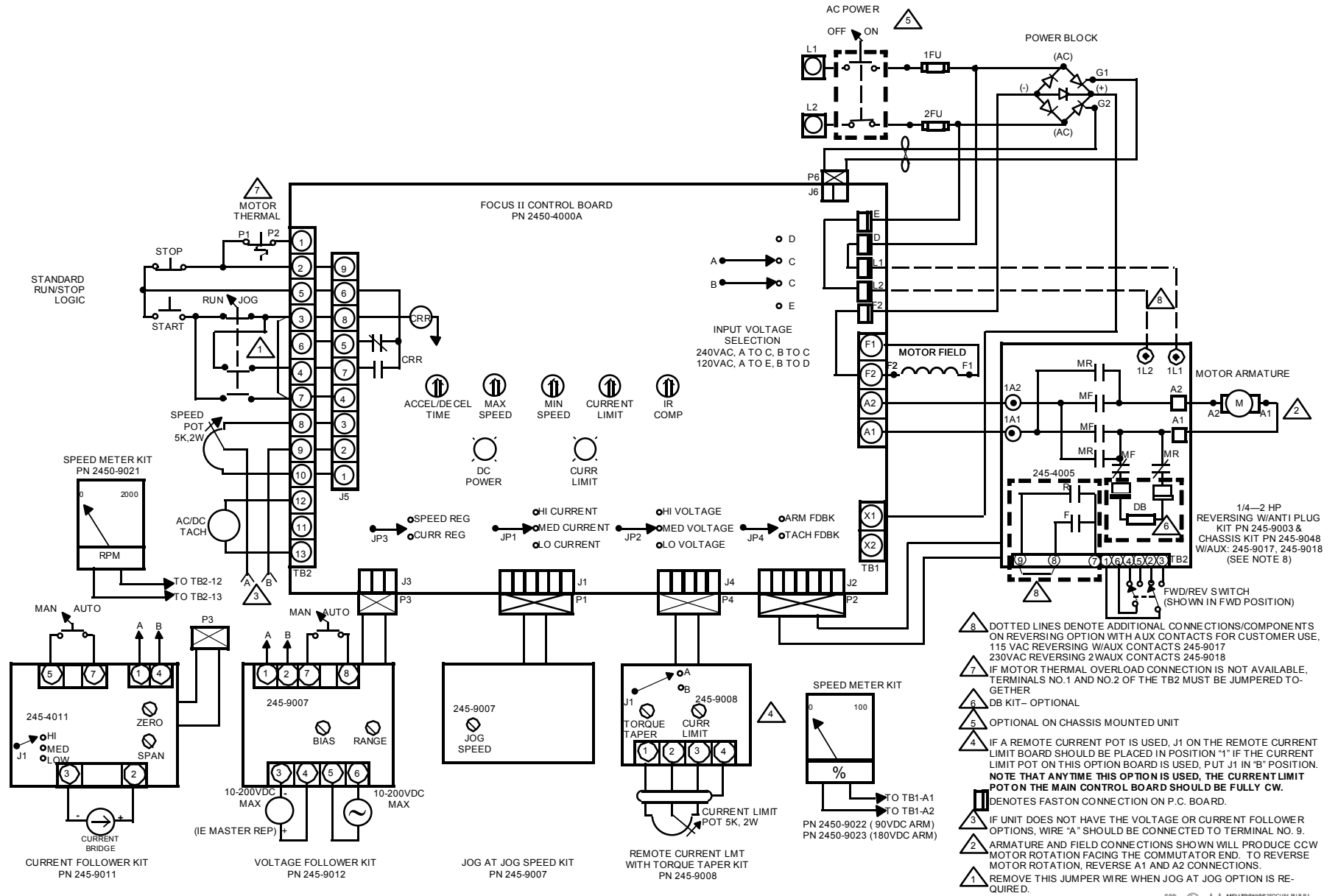

Figure 22: Enclosed Low HP Control with Reversing Kit, 2450-1004-I, Rev. A

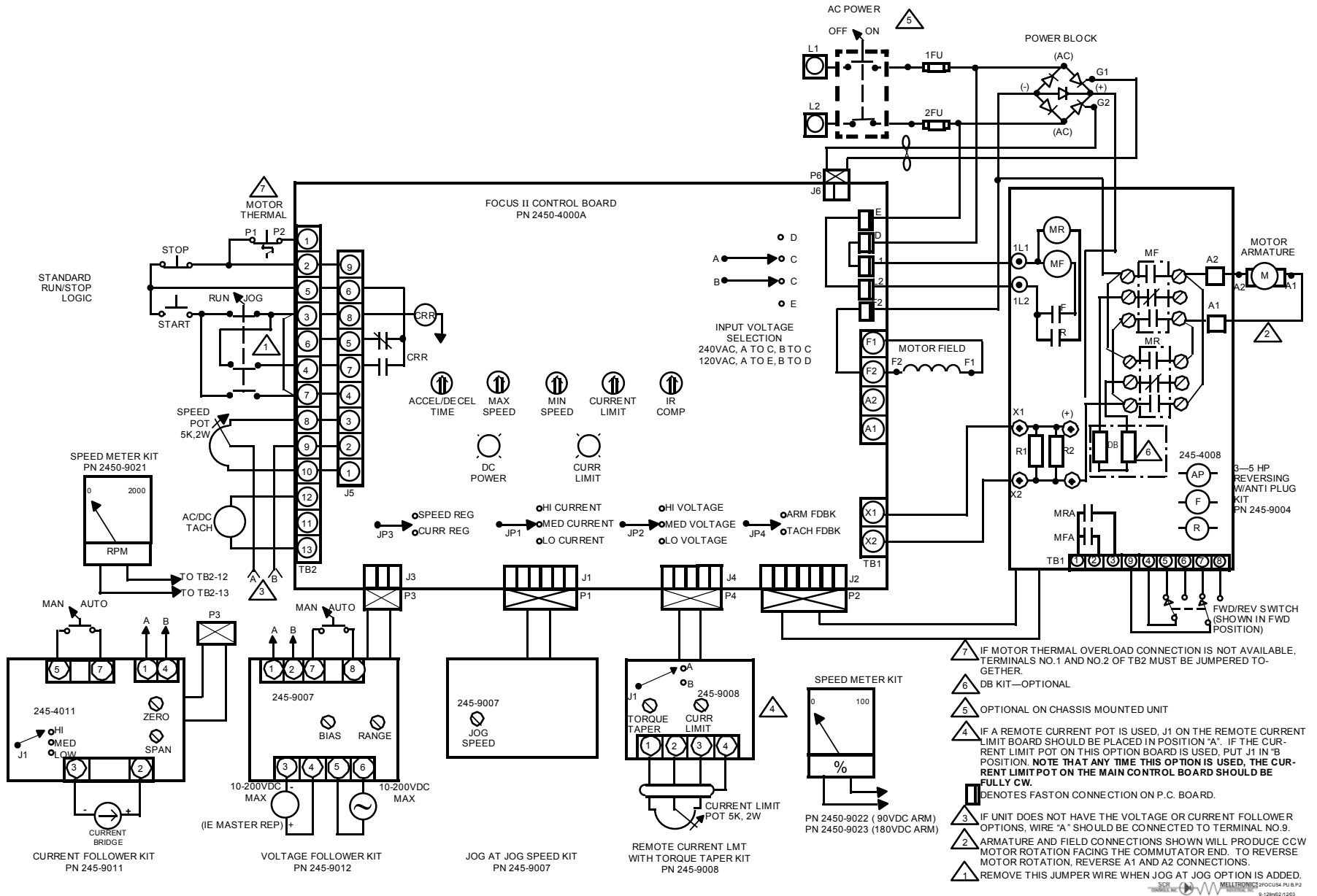
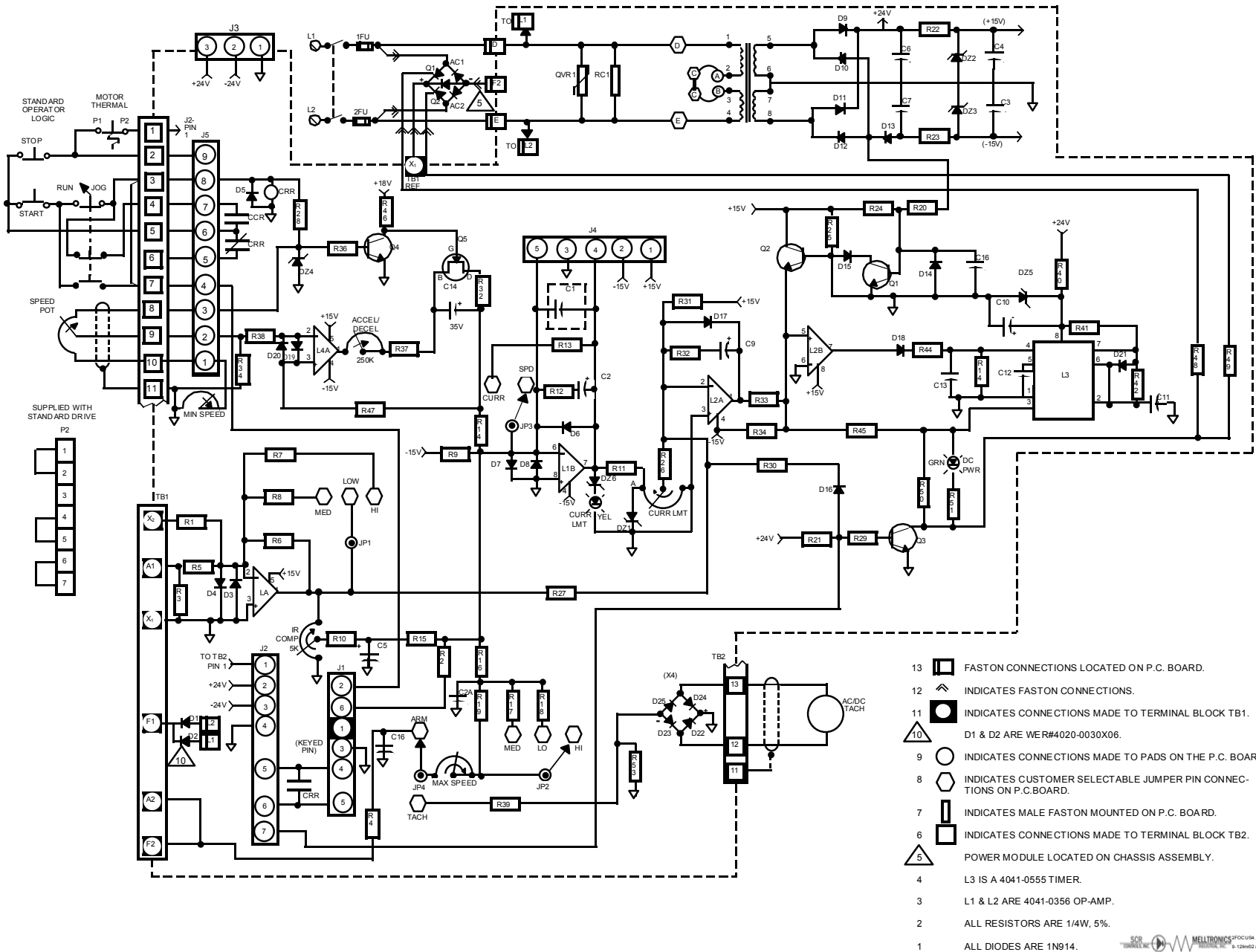
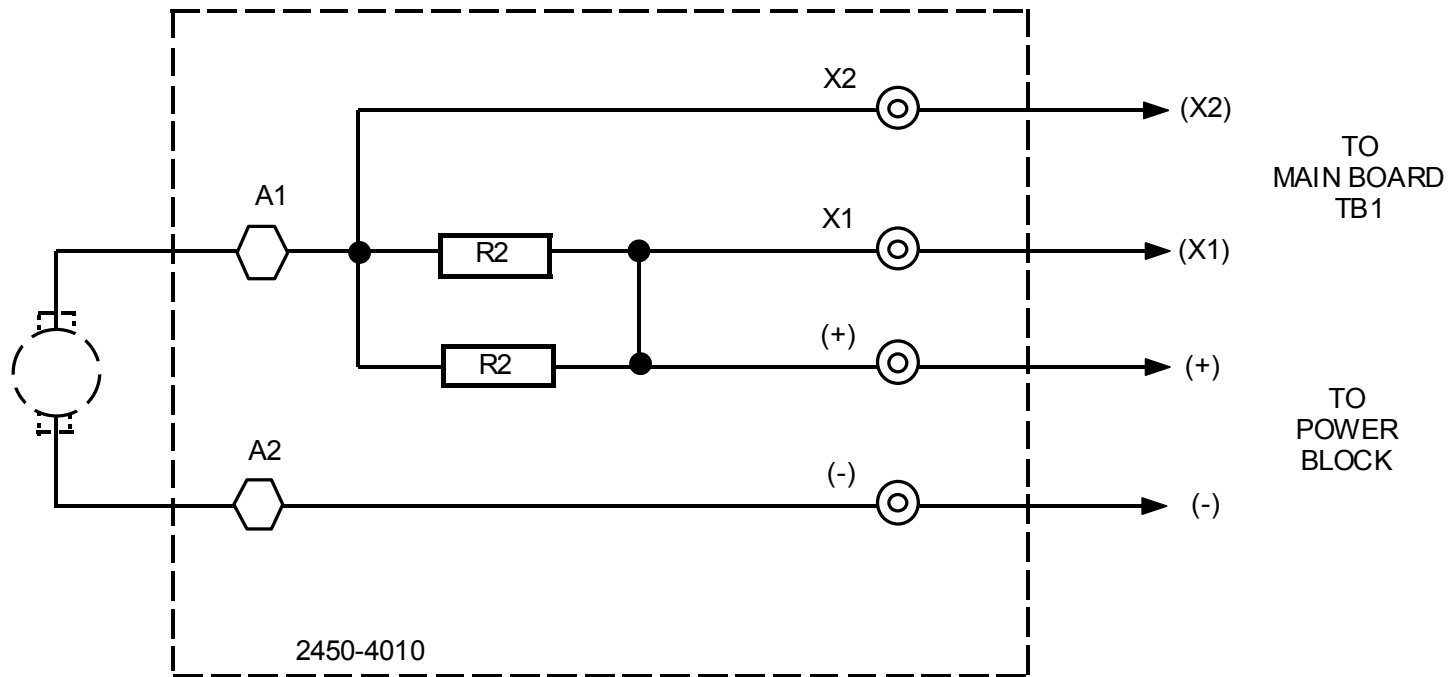

Figure 23: Enclosed High HP Control with Reversing Kit, 2450-1005-I, Rev. A



- 13 FASTON CONNECTIONS LOCATED ON P.C. BOARD.
- 12 INDICATES FASTON CONNECTIONS.
- 11 INDICATES CONNECTIONS MADE TO TERMINAL BLOCK TB1.
- 10 D1 & D2 ARE WER#4020-0030X06.
- 9 INDICATES CONNECTIONS MADE TO PADS ON THE P.C. BOARD.
- 8 INDICATES CUSTOMER SELECTABLE JUMPER PIN CONNECTIONS ON P.C. BOARD.
- 7 INDICATES MALE FASTON MOUNTED ON P.C. BOARD.
- 6 INDICATES CONNECTIONS MADE TO TERMINAL BLOCK TB2.
- 5 POWER MODULE LOCATED ON CHASSIS ASSEMBLY.
- 4 L3 IS A 4041-0555 TIMER.
- 3 L1 & L2 ARE 4041-0356 OP-AMP.
- 2 ALL RESISTORS ARE 1/4W, 5%.
- 1 ALL DIODES ARE 1N914.

Figure 24: Schematic Diagram Main PC Board, 2450-1000, Rev.C



⊙ INDICATES SOLDER PADS.

⬡ INDICATES BOLTED CONNECTIONS

SCR CONTROL, INC.  MELLTRONICS  FOCUS 2, PU B, P4
MELLTRONICS, INC. 9-12im02 r2/03

Figure 25: Shunt Resistor Board for High HP Enclosed & Less Operators Controls, 2450-1010, NoRev.

SECTION 10 BASIC APPLICATION

10.1 BASIC MECHANICS

Two (2) basic mechanical parameters, torque and horsepower, must be completely understood to properly apply DC drives.

10.1.1 TORQUE

Torque is a force applied that tends to produce rotation. Torque (force) without rotation is called static torque, since no motion is produced.

Torque is measured in pound-inch (lb-in) or pound-foot (lb-ft). It is the product of the force in pounds (lb) times (x) the distance in inches (in) or feet (ft) from the center of the point of apparent rotation. Figure 26 shows 120 lb-in (12in x 10lb) or 10 lb-ft of torque.

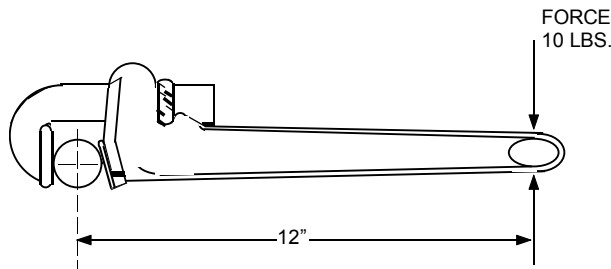

Figure 26: Example of 10 lb-ft Applied Torque

Because most power transmission is based upon rotating elements, torque is important as a measurement of the effort required to produce work.

10.1.2 HORSEPOWER

Horsepower is a measure of the rate at which work is being done. When a force is applied in a manner that produces motion, work can be measured. One (1) horsepower (HP) is defined as the force required to lift 33,000 lbs, one (1) foot, in one (1) minute.

10.2 TORQUE VS. HORSEPOWER

A simple formula exists that relates torque and horsepower to each other. This formula is:

$$\text{Horsepower} = \frac{\text{Torque (lb-ft)} \times \text{Speed (RPM)}}{5250}$$

10.3 MATCHING THE DRIVE TO THE MACHINE

The application of an adjustable speed drive to a machine is a mechanical, rather than an electrical problem. When applying the drive, the speed, torque, and horsepower characteristics developed at the motor shaft must be considered. These must meet or exceed the torque and horsepower requirements of the machine being driven.

The torque requirements of a machine fall into three major categories:

- Breakaway torque
- Accelerating torque
- Running Torque

10.3.1 BREAKAWAY TORQUE

Breakaway torque is the torque required to start a machine in motion. It is almost always greater than the torque required to maintain motion (running torque). In some applications, breakaway torque is a very important parameter that cannot be neglected.

10.3.2 ACCELERATING TORQUE

This is the torque required to bring the machine to operating speed within a given time. With most machines, the load is largely friction and a standard drive rating may have adequate torque for satisfactory acceleration. However, certain machines classified as "high inertia" with flywheels, bull gears or other large rotating masses may require drive selection based upon the power required to accelerate the load within a given time.

10.3.3 RUNNING TORQUE

This is the torque required to maintain machine motion after it accelerates to the desired operating speed. Running torque is usually a combination of the torque required to push, pull, compress, stretch or process the material plus the torque required to overcome frictional forces and windage. Running torque may vary as a complex function of operating speed. It is very important to understand the torque requirements of the application before attempting to apply a drive. In general, most applications will fall into one of the following categories:

- Constant torque
- Constant horsepower
- Variable torque

A limited number of machines may have operating characteristics that are a composite of the basic types.

Constant Torque – About 90% of all general industrial machines (other than pumps) are constant torque systems. The machine torque requirement is independent of its speed. If the machine speed is doubled, its horsepower requirement doubles. Constant torque is illustrated in Figure 27.

Constant Horsepower – For machines with constant horsepower loads, the power demand is independent of speed and torque varies inversely with speed. This type is most often found in the machine tool industry and with center driven winders. When drilling, shaping, milling, or turning metal, the loads all tend toward constant horsepower. At low speed there is high torque; at high speed, light torque. A drive must be selected for its highest torque condition that is at the lowest speed. Constant horsepower is illustrated in Figure 28.

Variable Torque – This type of load is commonly found on centrifugal pump drives and in most fan or blower applications. The torque and horsepower both vary with speed. Variable torque is illustrated in Figure 29

10.4 DC DRIVE CHARACTERISTICS

10.4.1 CONSTANT TORQUE APPLICATIONS

Armature voltage controlled DC drives are constant-torque drives. They are capable of providing rated torque at any speed between zero and the base (rated) speed of the motor. Horsepower varies in direct proportion to speed, and 100% rated horsepower is developed only at 100% rated motor speed with rated torque.

10.4.2 CONSTANT HORSEPOWER APPLICATIONS

A. Armature Controlled DC Drives – Certain applications require constant horsepower over a specified speed range. Since an armature voltage controlled DC drive has constant torque characteristics, the drive must be oversized to handle these applications. A drive required to deliver constant horsepower over a 2:1 speed range has to be rated at twice the required horsepower since it only develops 50% of its rated horsepower at half speed. The horsepower rating required for any constant torque drive operated in a constant horsepower application can be easily calculated as follows. Multiply the desired horsepower by the ratio of the speed range over which horsepower must remain constant. If 5HP is required over a 2:1 range, and armature only controlled drive rated for 10 horsepower (5 HP x 2) would be required.

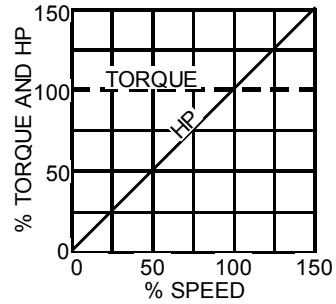

Figure 27: Constant Torque

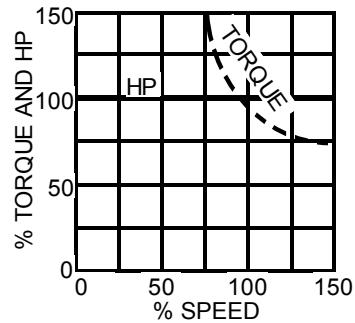

Figure 28: Constant Horsepower

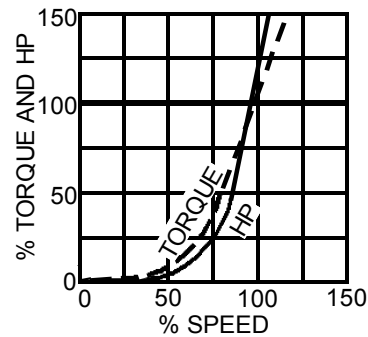

Figure 29: Variable Torque

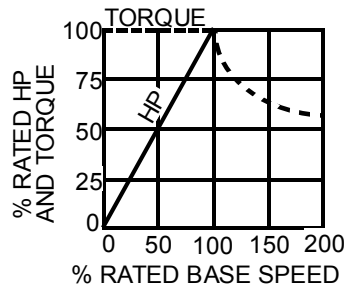

Figure 30: Motor Armature Voltage Control and Field Control

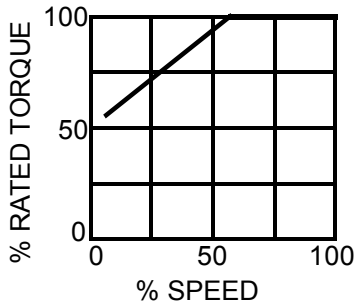

Figure 31: Constant Torque Speed Range

B. Field Controlled DC Drives - Another characteristic of a shunt-wound DC motor is that a reduction in field voltage to less than the design rating results in an increase in speed for a given armature voltage. It is important to note, however, that this results in a higher armature current for a given motor load. A simple method of accomplishing this is by inserting a resistor in series with the field voltage source. This may be useful for achieving an ideal motor speed for the application. An optional, more sophisticated method uses a variable voltage field regulator. This provides coordinated automatic armature and field voltage control for extended speed range in constant HP applications. The motor is armature voltage controlled for constant torque-variable HP operation to base speed. It is then transferred to field control for constant HP-variable torque operation to maximum speed. This is illustrated in Figure 30.

10.5 OTHER MECHANICAL CONSIDERATIONS

10.5.1 CONSTANT TORQUE SPEED RANGE

When a DC drive is operated continuously at low speed and rated torque, motor heating problems may be encountered. At reduced speeds, the motor internal cooling fan is less effective and overheating occurs if the motor remains fully loaded. A typical self ventilated DC motor continuous torque rating as a function of speed is shown in Figure 31. When continuous operation is required at rated torque and reduced speed, supplemental motor ventilation such as a motor mounted blower or separate ventilation duct must be supplied. An oversized motor (one that does not have to produce rated torque) or a totally enclosed nonventilated (TENV) motor may also be used in these conditions.

10.5.2 TORQUE LIMITATIONS

Most adjustable speed drives feature a torque limiter to protect the drive and the machine from torque overloads. The torque limiter (current limit) is normally adjustable to 150% of rated torque to allow extra momentary torque for breakaway, acceleration or cyclic overloads. Most drive systems are capable of sustaining the 150% torque for 1 minute or less.

10.5.3 DUTY CYCLE

Certain applications may require continuous reversals, long acceleration times at high torque due to inertia loads, frequent high rate acceleration or cyclic overloads. These may result in severe motor heating if not considered in the selection of the drive. Most drives with 150% overload capability operate successfully if there are compensating periods of operation where motor temperature can be normalized.

10.5.4 OVERHAULING LOADS

In some applications, process tension differences, downhill loads, or machine inertia may cause the driven machine to overhaul the drive motor. In these applications, the DC motor must provide holdback torque to brake the load. A regenerative drive is usually required in these applications.

10.6 MOTOR APPLICATION FORMULAS

10.6.1 CALCULATING HORSEPOWER

Once the machine torque requirement is determined, horsepower can be calculated using the formula:

$$\text{Horsepower} = \frac{\text{Torque (lb-ft)} \times \text{Base of Motor Speed (RPM)}}{5250}$$

Where HP equals Horsepower

T equals Torque (lb-ft)

N equals Base Speed of Motor (RPM).

If the calculated horsepower falls between standard available motor ratings, select the higher available horsepower rating. It is good practice to allow some margin when selecting the motor horsepower.

For many applications, it is possible to calculate the horsepower required without actually measuring the torque required. The following useful formulas will help:

A. For Conveyors

$$\text{HP (Vertical)} = \frac{\text{Weight (lb)} \times \text{Velocity (FPM)}}{33,000}$$

$$\text{HP (Horizontal)} = \frac{\text{Weight (lb)} \times \text{Velocity (FPM)} \times \text{Coef. Of friction}}{33,000}$$

B. For Web Transport Systems and Surface Winders

$$\text{Horsepower} = \frac{\text{Tension (lb)} \times \text{Velocity (FPM)}}{33,000}$$

NOTE THAT THE TENSION VALUE USED IN THIS CALCULATION IS THE ACTUAL WEB TENSION FOR SURFACE WINDER APPLICATIONS, BUT IT IS THE TENSION DIFFERENTIAL (DOWNSTREAM TENSION – UPSTREAM TENSION) FOR SECTIONAL DRIVES.

C. Center Winders (Armature Control Only)

$$\text{HP} = \frac{\text{Tension (lb)} \times \text{Line Speed (FPM)} \times \text{Buildup}}{33,000 \times \text{Taper}}$$

D. Center Winders (Field Control)

If Taper x Field Range \geq Buildup

$$\text{HP} = \frac{\text{Tension (lb)} \times \text{Line Speed (FPM)}}{33,000}$$

If Taper x Field Range \leq Buildup

$$\text{HP} = \frac{\text{Tension (lb)} \times \text{Line Speed (FPM)} \times \text{Buildup}}{33,000 \times \text{Taper} \times \text{Field Range}}$$

CAUTION

THE ABOVE FORMULAS FOR CALCULATING HORSEPOWER DO NOT INCLUDE ANY ALLOWANCE FOR MACHINE FUNCTION WINDAGE OR OTHER FACTORS. THESE FACTORS MUST BE CONSIDERED WHEN SELECTING A DRIVE FOR A MACHINE APPLICATION.

E. For Fans and Blowers

$$\text{HP} = \frac{\text{CFM} \times \text{Pressure (lb/ft}^2\text{)}}{33,000 \times \text{(Eff. Of Fan)}}$$

Effect of speed on HP:

HP = $K_1(\text{RPM})^3$ – Horsepower varies as the 3rd power of speed

T = $k_1(\text{RPM})^2$ – Torque varies as the 2nd power of speed.

Flow = $k_3(\text{RPM})$ – Flow varies directly as the speed.

$$\text{HP} = \frac{\text{CFM} \times \text{Pressure (lb/in}^2\text{)}}{229 \times \text{(Eff. Of Fan)}}$$

$$\text{HP} = \frac{\text{CFM} \times \text{Inches of Water Gauge}}{6356 \times \text{(Eff. Of Fan)}}$$

F. For Pumps

$$\text{HP} = \frac{\text{GPM} \times \text{Head (ft)} \times \text{(Specific Gravity)}}{3960 \times \text{(Eff. Of Fan)}}$$

Specific gravity of water = 1.0

1 cu. Ft. per sec = 448 GPM

1 PSI = A head of 2.309 ft. for water weighing 62.36 lbs./ft.³ and 62°F

Displacement pump efficiency:

Displacement pumps may vary between 50% and 80% efficiency, depending on size of pumps.

Centrifugal pump efficiency:

500 to 1000 gal. Per min = 70% to 75%

1000 to 1500 gal. Per min = 75% to 80%

Larger than 1500 gal. Per min. = 80% to 85%

10.6.2 INERTIA (WK²)

The factor WK is the Weight (lb) of an object multiplied by the square of the Radius of Gyration (K). The unit measurement of the radius of gyration is expressed in feet.

For solid or hollow cylinders, inertia may be calculated by using the equations given here.

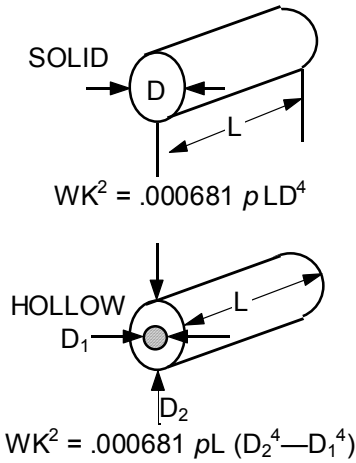

$WK^2 = \text{lb. ft.}^2$
 $D, D_1, D_2 \text{ \& } L = \text{in.}$
 $\rho = \text{lb./in.}^3$

ρ (aluminum) = .0924
 ρ (bronze) = .320
 ρ (cast iron) = .260
 ρ (steel) = .282
 ρ (paper) = .0289

Table 7: Density Factors
SHAFT MATERIAL FACTOR

Rubber	0.121
Nylon	0.181
Aluminum	0.348
Bronze	1.135
Cast Iron	0.922
Steel	1.00

The inertia of complex, concentric rotating parts may be calculated by breaking the part up into simple rotating cylinders, calculating their inertias and summing their values, as shown in the following diagram.

Table 8: Inertia of Steel Shafting (per inch of length)

Dia. (in)	WK2(=lb-ft ²)	Dia. (in)	WK2(=lb-ft ²)
3/4	.00006	10 1/2	2.35
1	.0002	10 3/4	2.58
1 1/4	.0005	11	2.83
1 1/2	.001	11 1/4	3.09
1 3/4	.002	11 1/2	3.38
2	.003	11 3/4	3.68
2 1/4	.005	12	4.00
2 1/2	.008	12 1/4	4.35
2 3/4	.011	12 1/2	4.72
3	.016	12 3/4	5.11
3 1/2	.029	13	5.58
3 3/4	.038	13 1/4	5.96
4	.049	13 1/2	6.42
4 1/4	.063	13 3/4	6.91
4 1/2	.079	14	7.42
5	.120	14 1/4	7.97
5 1/2	.177	14 1/2	8.54
6	.250	14 3/4	9.15
6 1/4	.296	15	9.75
6 1/2	.345	16	12.59
6 3/4	.402	17	16.04
7	.464	18	20.16
7 1/4	.535	19	25.03
7 1/2	.611	20	30.72
7 3/4	.699	21	37.35
8	.791	22	44.99
8 1/4	.895	23	53.74
8 1/2	1.00	24	63.71
8 3/4	1.13	25	75.02
9	1.27	26	87.76
9 1/4	1.41	27	102.06
9 1/2	1.55	28	118.04
9 3/4	1.75	29	135.83
10	1.93	30	155.55
10 1/4	2.13		

10.6.3 WK² OF ROTATING ELEMENTS

In practical mechanical systems, all the rotating parts do not operate at the same speed. The WK² of all moving parts operating at each speed must be reduced to an equivalent WK² at the motor shaft, so that they can all be added together and treated as a unit, as follows:

$$\text{Equivalent } WK^2 = WK^2 \left(\frac{N}{N_m} \right)^2$$

Where

WK² = inertia of the moving part

N = speed of the moving part (RPM)

N_m = speed of the driving motor (RPM)

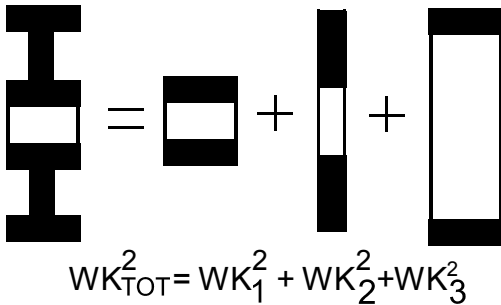

When using speed reducers, and the machine inertia is reflected back to the motor shaft, the equivalent inertia is equal to the machine inertia divided by the square of the drive reduction ratio.

10.6.4 WK² OF LINEAR MOTION

Not all driven systems involve rotating motion. The equivalent WK² of linearly moving parts can also be reduced to the motor shaft speed as follows:

$$\text{Equivalent } WK^2 = \frac{W (V)^2}{39.5 (N_m)^2}$$

Where

W = weight of load (lb)

V = linear velocity of rack and load or conveyor and load (FPM)

N_m = speed of the driving motor (RPM)

This equation can only be used where the linear speed bears a continuous fixed relationship to the motor speed, such as a conveyor.

10.7 ELECTRICAL FORMULAS

Ohms Law:

$$\text{Amperes} = \frac{\text{Volts}}{\text{Ohms}} \quad \text{Ohms} = \frac{\text{Volts}}{\text{Amperes}}$$

$$\text{Volts} = \text{Amperes} \times \text{Ohms}$$

Power in DC Circuits:

$$\text{Watts} = \text{Volts} \times \text{Amperes}$$

$$\text{Horsepower} = \frac{\text{Volts} \times \text{Amperes}}{746}$$

$$\text{Kilowatts} = \frac{\text{Volts} \times \text{Amperes}}{1000}$$

$$\text{Kilowatt-Hours} = \frac{\text{Volts} \times \text{Amperes} \times \text{Hours}}{1000}$$

Power in AC Circuits:

Kilovolt – Amperes (kVA)

$$\text{kVA (Single-Phase)} = \frac{\text{Volts} \times \text{Amperes}}{1000}$$

$$\text{kVA (Three-Phase)} = \frac{\text{Volts} \times \text{Amperes} \times 1.73}{1000}$$

$$\text{kW (Single-Phase)} = \frac{\text{Volts} \times \text{Amperes} \times \text{Power Factor}}{1000}$$

$$\text{kW(Three-Phase)} = \frac{\text{Volts} \times \text{Amperes} \times \text{Power Factor} \times 1.73}{1000}$$

$$\text{Power Factor} = \frac{\text{Kilowatts}}{\text{Kilovolts} \times \text{Amperes}}$$

10.8 OTHER USEFUL FORMULAS

- 1kW = 56.88 BTU/min.
- 1HP = 0.7457kW
- = 550 lb-ft per sec.
- = 33,000 lb-ft per min.
- = 2545 BTU per hour

TEMPERATURE CONVERSION

$$\text{Degrees C} = (\text{Degrees F} - 32) \times 5/9$$

$$\text{Degrees F} = (\text{Degrees C} \times 9/5) + 32$$

**APPENDIX A
GLOSSARY**

Constant HP Load-	A load requiring high torque at low speeds, low torque at high speeds, and thus constant horsepower at any speed.
Constant Torque Load-	A load requiring the same amount of torque at low speed as at high speed. Torque remains constant throughout the speed range, and the horsepower increases and decreases in direct proportion to the speed.
CRR-	Control run relay.
Horsepower-	A measure of the rate at which work is being done. One (1) horsepower (HP) is defined as the force required to lift 33,000 lbs, one foot in one minute.
IR Compensation-	An adjustment that overcomes the natural tendency for a motor to decelerate with increasing load.
LED-	Light emitting diode.
Non-Regenerative Drive-	One that rotates the DC motor in only one direction to supply rotational energy or torque into the load.
Overhauling Load-	A load such as a process tension difference, a downhill load or machine inertia that requires the motor to provide holdback torque to brake the load. A regenerative drive or energy absorber kit is usually required in these applications.
Regenerative Drive-	One that can both deliver and remove electrical energy to or from a motor. In this manner, rotational mechanical energy can be supplied to or be removed from a load.
SCR-	Silicon controlled rectifier.
TENV-	Totally Enclosed Non-Ventilated.
Torque-	A force applied that tends to produce rotation. Breakaway torque is the torque required to start a machine in motion. Accelerating torque is the torque required to bring the machine to operating speed within a given time. Running torque is the torque required to maintain machine motion after it accelerates to the desired operating speed.
Variable Torque Load-	A load requiring much lower torque at low speeds than at high speeds. Horsepower varies approximately as the cube of the speed, and the torque varies approximately as the square of the speed.

REVISION UPDATES

REV	DATE	DESCRIPTION	REVISIONS
NONE	08/20/03	1 ST RELEASE BY SCR/MELLTRONICS	NONE
A	05/16/05	2 ND RELEASE BY MELLTRONICS	MISCELANEOUS SPELLING CHANGES

SECTION 11 WARRANTY

SCR/MELLTRONICS warrants to the Buyer whom purchases for use and not for resale that the equipment described in this instruction manual is sold in accordance with published specifications or the specifications agreed to in writing at the time of sale. SCR/Melltronics further warrants that such goods are free of defects in material and workmanship.

The warranty shall apply for a period of twelve months (12) from date of purchase, not to exceed eighteen months (18) from the date of manufacture.

If the goods fail to perform to SCR/Melltronics specifications as outlined in the warranty, then Buyer should contact SCR/Melltronics to obtain a "Return Material Authorization" (RMA), prepare the goods for shipment and return the goods to SCR Melltronics for repair or replacement at SCR/Melltronics option. Buyer will bear all costs of transportation to and from SCR/Melltronics factory, risk of loss for goods not at SCR/Melltronics factory and any cost required to remove or prepare the goods for shipment to the repair facility, and to reinstall equipment subsequent to repair.

This warranty is effective only if written notification of any claim under this warranty is received by SCR/Melltronics at the address indicated below within thirty-days (30) from recognition of defect by Buyer.

The above indicates the full extent of SCR/Melltronics liability under this warranty. SCR/Melltronics specifically disclaims any liability for: (a) damage or failure due to improper use or installation; (b) damages in shipment; (c) damage or failure due to abnormal operation conditions of load, temperature, altitude or atmosphere whether intentional or unintentional; (d) non-authorized service, repair, modification, inspection, removal, transportation or installation; (e) misapplication or misuse, or; (f) consequential damages arising out of the use, operation or maintenance of the goods.

THERE ARE NO OTHER WARRANTIES, EXPRESSED OR IMPLIED, WHICH EXTEND BEYOND THAT DESCRIBED HEREIN. SCR MELLTRONICS SPECIFICALLY DISCLAIMS ANY IMPLIED WARRANTY OF MERCHANTABILITY OF GOODS OR OF THE FITNESS OF THE GOODS FOR ANY PURPOSE.

SCR/MELLTRONICS NEITHER ASSUMES NOR AUTHORIZES ANY REPRESENTATIVE OR ANY OTHER PERSON TO ASSUME FOR SCR/MELLTRONICS ANY OTHER LIABILITY IN CONNECTION WITH THE SALE OR ANY SHIPMENT OF SCR/MELLTRONICS GOODS. SCR/MELLTRONICS RESERVES THE RIGHT TO MAKE CHANGES AND IMPROVEMENTS IN MELLTRONICS GOODS WITHOUT INCURRING ANY OBLIGATION TO SIMILARLY AFTER GOODS PREVIOUSLY PURCHASED.



MAIL: PO BOX 2368
INDIAN TRAIL, NC 28079-2368
SHIPPING: 3479 GRIBBLE ROAD
MATTHEWS, NC 28104-8114

PHONE: 704-821-6651
www.melltronics.com