

# SIEMENS

Introduction

1

Product Information

2

## SIMATIC

### Distributed I/O System ET 200S

Product Information

## Safety Guidelines

This manual contains notices you have to observe in order to ensure your personal safety, as well as to prevent damage to property. The notices referring to your personal safety are highlighted in the manual by a safety alert symbol, notices referring only to property damage have no safety alert symbol. These notices shown below are graded according to the degree of danger.



---

### Danger

indicates that death or severe personal injury **will** result if proper precautions are not taken.

---



---

### Warning

indicates that death or severe personal injury **may** result if proper precautions are not taken.

---



---

### Caution

with a safety alert symbol, indicates that minor personal injury can result if proper precautions are not taken.

---

---

### Caution

without a safety alert symbol, indicates that property damage can result if proper precautions are not taken.

---

---

### Notice

indicates that an unintended result or situation can occur if the corresponding information is not taken into account.

---

If more than one degree of danger is present, the warning notice representing the highest degree of danger will be used. A notice warning of injury to persons with a safety alert symbol may also include a warning relating to property damage.

## Qualified Personnel

The device/system may only be set up and used in conjunction with this documentation. Commissioning and operation of a device/system may only be performed by **qualified personnel**. Within the context of the safety notes in this documentation qualified persons are defined as persons who are authorized to commission, ground and label devices, systems and circuits in accordance with established safety practices and standards.

## Prescribed Usage

Note the following:



---

### Warning

This device may only be used for the applications described in the catalog or the technical description and only in connection with devices or components from other manufacturers which have been approved or recommended by Siemens. Correct, reliable operation of the product requires proper transport, storage, positioning and assembly as well as careful operation and maintenance.

---

## Trademarks

All names identified by ® are registered trademarks of the Siemens AG. The remaining trademarks in this publication may be trademarks whose use by third parties for their own purposes could violate the rights of the owner.

## Disclaimer of Liability

We have reviewed the contents of this publication to ensure consistency with the hardware and software described. Since variance cannot be precluded entirely, we cannot guarantee full consistency. However, the information in this publication is reviewed regularly and any necessary corrections are included in subsequent editions.

# Table of contents

<b>1</b>	<b>Introduction</b> .....	<b>1-1</b>
1.1	Introduction .....	1-1
<b>2</b>	<b>Product Information</b> .....	<b>2-1</b>
2.1	Interrupt, Error and System Messages at 8DI / 8DO .....	2-1
2.2	Digital Electronic Module 8DI DC24V (6ES7131-4BF00-0AA0).....	2-2
2.3	Digital Electronic Module 8DO DC24V/0.5A (6ES7132-4BF00-0AA0).....	2-7
	<b>Index</b> .....	<b>Index-1</b>



# Introduction

## 1.1 Introduction

This product information describes supplements to the *ET 200S Distributed I/O System Operating Instructions* (A5E00515771-03), release 12/2005 and to the *ET 200S Distributed I/O System Manual* (A5E00514527-03), release 12/2005.

The chapter number mentioned in this product information refer to the chapters in the ET 200S Distributed I/O System Operating Instructions (A5E00515771-03), release 12/2005 and to the ET 200S Distributed I/O System Manual (A5E00514527-03), release 12/2005.

### Contents of this Product Information

The product spectrum of the ET 200S is supplemented by the 8-channel digital electronic modules 8DI DC24V and 8DO DC24V 0.5A.

Section	Contents of this Product Information	Manual
2.1	Interrupt, error and system messages at 8DI / 8DO	Supplements Chapter 8 of the operating instructions
2.2	Digital electronic module 8DI DC24V	Supplements Chapter 3 in the manual
2.3	Digital electronic module 8 DO DC 24V/0.5A	

### Prerequisites for Operating the Digital Electronic Modules with the Interface Modules

Operation of the digital electronic modules 8DI DC24V/ 8DO DC24V 0.5A is possible with the following interface modules from the specified order numbers (or firmware version). There are no limitations at the interface modules listed in the table.

Interface module	As of Order Number	As of Firmware Version
IM 151-1 STANDARD	6ES7151-1AA03-0AB0	---
IM 151-1 FO STANDARD	6ES7151-1AB02-0AB0	---
IM 151-1 HIGH FEATURE	6ES7151-1BA01-0AB0	V2.1.3
IM 151-3 PN	6ES7151-3AA20-0AB0	V4.0.1
IM 151-3 PN HIGH FEATURE	6ES7151-3BA20-0AB0	
IM 151-3 PN FO	6ES7151-3BB21-0AB0	



## Product Information

### 2.1 Interrupt, Error and System Messages at 8DI / 8DO

#### Digital electronic modules 8DI DC24V, 8DO DC24V 0.5A

LED display at 8DI DC24V, 8DO DC24V 0.5A:

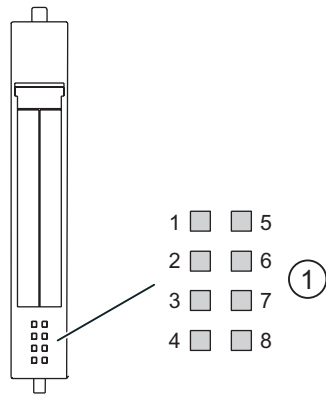

① Status display for input/output status (green)

#### Status and error displays by means of LEDs at 8DI DC24V, 8DO DC24V 0.5A

The table below shows the status and error displays at the digital electronic modules.

Event (LEDs)								Cause	Remedy
1	5	2	6	3	7	4	8		
On								Input/output on channel 0 active.	---
	On							Input/output on channel 1 active.	---
		On						Input/output at Channel 2 active.	---
			On					Input/output at Channel 3 active.	---
				On				Input/output at Channel 4 active.	---
					On			Input/output at Channel 5 active.	---
						On		Input/output at Channel 6 active.	---
							On	Input/output at Channel 7 active.	---

## 2.2 Digital Electronic Module 8DI DC24V (6ES7131-4BF00-0AA0)

### Properties

- Digital electronic module with eight inputs
- Nominal input voltage 24 VDC
- Suitable for connecting 2-wire sensors
- Isochronous mode supported

### General terminal assignment

---

#### Note

Terminals A4, A8, A3 and A7 are only available at specified terminal modules.

---

Pin assignment for 8DI DC24V (6ES7131-4BF00-0AA0)				
Terminal	Assignment	Terminal	Assignment	Notes
1	DI <sub>0</sub>	5	DI <sub>1</sub>	<ul style="list-style-type: none"><li>• DI<sub>n</sub>: Input signal, Channel n</li><li>• AUX1: Sensor power supply 24 VDC (for example from power module) or potential bus (can be used freely up to 230 VAC)</li></ul>
2	DI <sub>2</sub>	6	DI <sub>3</sub>	
3	DI <sub>4</sub>	7	DI <sub>5</sub>	
4	DI <sub>6</sub>	8	DI <sub>7</sub>	
A4	AUX1	A8	AUX1	
A3	AUX1	A7	AUX1	

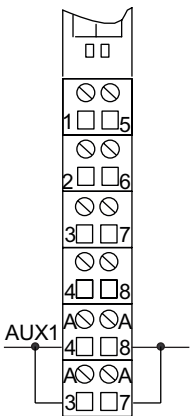
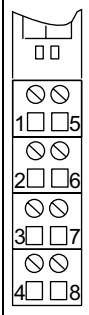
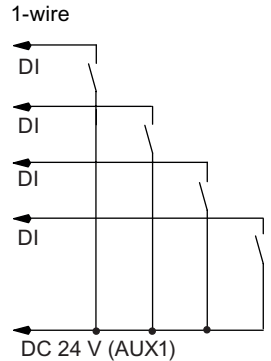

Usable terminal modules

Usable terminal modules for 8DI DC24V (6ES7131-4BF00-0AA0)		
TM-E15C26-A1 (6ES7193-4CA50-0AA0)	TM-E15C24-01 (6ES7193-4CB30-0AA0)	← Spring terminal
TM-E15S26-A1 (6ES7193-4CA40-0AA0)	TM-E15S24-01 (6ES7193-4CB20-0AA0)	← Screw-type terminal
TM-E15N26-A1 (6ES7193-4CA80-0AA0)	TM-E15N24-01 (6ES7193-4CB70-0AA0)	← Fast Connect
<div style="display: flex; justify-content: space-between;"> <div style="width: 30%;">  </div> <div style="width: 30%;">  </div> <div style="width: 30%;"> <p>Wiring examples</p> <p>1-wire</p>  </div> </div>		

2-wire connection

The following configuration example shows a 2-wire connection with the electronic modules 8DI DC24V. You require further terminals so that sufficient terminals are available for the 24 VDC sensor power supply when the TM-E15S26-A1 terminal modules are used. In the example this is implemented by the add-on terminal TE-U120S4x10. Per add-on terminal, terminal modules of the same height must exist across a minimum width of 120 mm. You can naturally also use other terminals for this configuration (for example, ET 200S potential distribution module 4POTDIS).

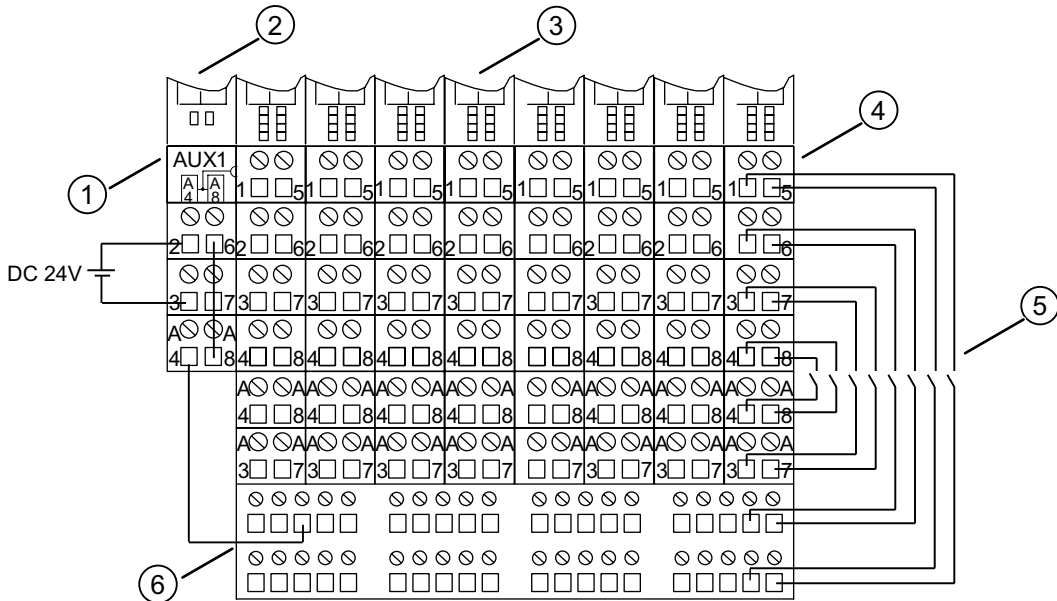

- ① Terminal module TM-P15S23-A0
- ② Power module PM-E 24 VDC
- ③ Electronic modules 8DI DC24V
- ④ Terminal modules TM-E15S26-A1
- ⑤ Sensor in 2-wire connection
- ⑥ Add-on terminal TE-U120S4x10

Block Diagram

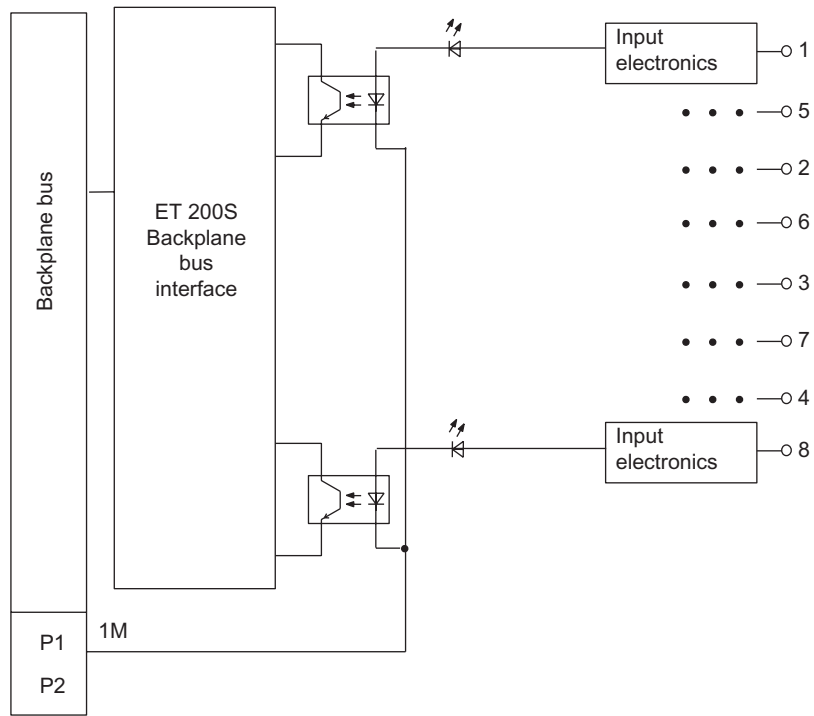

Figure 2-1 Block diagram of the 8DI DC24V

**Technical Specifications 8DI DC24V (6ES7131-4BF00-0AA0)**

<b>Dimensions and weight</b>	
Dimensions W × H × D (mm) (the total dimensions depend on the selected terminal module)	15 × 81 × 52
Weight	Approx. 35 g
<b>Module-specific data</b>	
Supports isochronous operation	Yes
Number of inputs	8
Length of cable	
• Unshielded	600 m, maximum
• Shielded	1000 m, maximum
Parameter length	3 bytes
<b>Voltages, currents, potentials</b>	
Rated supply voltage (from the power module)	24 VDC
• Reverse polarity protection	Yes
Electrical isolation	
• Between the channels	No
• Between the channels and backplane bus	Yes
Permissible potential difference	
• Between the different circuits	75 VDC / 60 VAC
Insulation test voltage	500 VDC
Current consumption	
• From supply voltage	Dependent on the sensor
Power dissipation of the module	Typically 1.2 W
<b>Status, interrupts, diagnostics</b>	
Status display	Green LED per channel
Diagnostics function	No
<b>Data for selecting a sensor</b>	
Input voltage	
• Rated value	24 VDC
• For signal "1"	15 V to 30 V
• For signal "0"	-30 V to 5 V
Input current	
• At signal "1"	Typ. 7 mA (for 24 V)
Input delay	
• At "0" to "1"	Typ. 3 ms (2.0 to 4.5 ms)
• At "1" to "0"	Typ. 3 ms (2.0 to 4.5 ms)
Input characteristic curve	According to IEC 61131, Type 1
Connection of 2-wire BEROs	Supported
• Permitted bias current	Max. 1.5 mA

## 2.3 Digital Electronic Module 8DO DC24V/0.5A (6ES7132-4BF00-0AA0)

### Properties

- Digital electronic module with eight outputs
- Output current 0.5 A per output, aggregate current 4 A
- Rated load voltage 24 VDC
- Short-circuit protection
- Suitable for solenoid valves, DC contactors, and indicator lights
- Isochronous mode supported

### General terminal assignment

---

#### Note

Terminals A4, A8, A3 and A7 are only available at specified terminal modules.

---

Pin assignment for 8DO DC24V/0.5A (6ES7132-4BF00-0AA0)				
Terminal	Assignment	Terminal	Assignment	Notes
1	DO <sub>0</sub>	5	DO <sub>1</sub>	<ul style="list-style-type: none"> <li>• DO<sub>n</sub>: Input signal, Channel n</li> <li>• AUX1: M chassis ground (from power module) or potential bus (freely usable up to 230 VAC)</li> </ul>
2	DO <sub>2</sub>	6	DO <sub>3</sub>	
3	DO <sub>4</sub>	7	DO <sub>5</sub>	
4	DO <sub>6</sub>	8	DO <sub>7</sub>	
A4	AUX1	A8	AUX1	
A3	AUX1	A7	AUX1	

Usable Terminal Modules

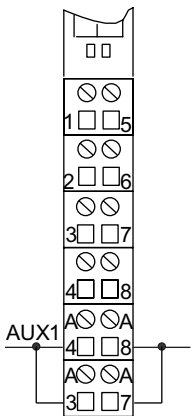
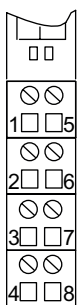
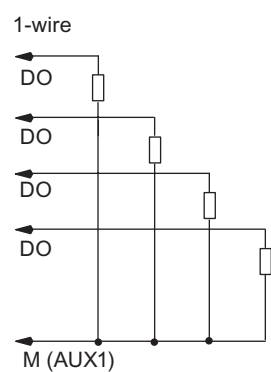
Usable terminal modules for 8DO DC24V/0.5A (6ES7132-4BF00-0AA0)		
TM-E15C26-A1 (6ES7193-4CA50-0AA0)	TM-E15C24-01 (6ES7193-4CB30-0AA0)	← Spring terminal
TM-E15S26-A1 (6ES7193-4CA40-0AA0)	TM-E15S24-01 (6ES7193-4CB20-0AA0)	← Screw-type terminal
TM-E15N26-A1 (6ES7193-4CA80-0AA0)	TM-E15N24-01 (6ES7193-4CB70-0AA0)	← Fast Connect
		<p>Wiring examples</p> <p>1-wire</p> 

## 2-wire connection

The following configuration example shows a 2-wire connection with the electronic modules 8DO DC24V. You require further terminals so that sufficient terminals are available for the chassis ground connection M when the TM-E15S26-A1 terminal modules are used. In the example this is implemented by the add-on terminal TE-U120S4x10 that can be mounted as from a width of 120 mm (8 EMs). You can naturally also use other terminals for this configuration (for example, ET 200S potential distribution module 4POTDIS).

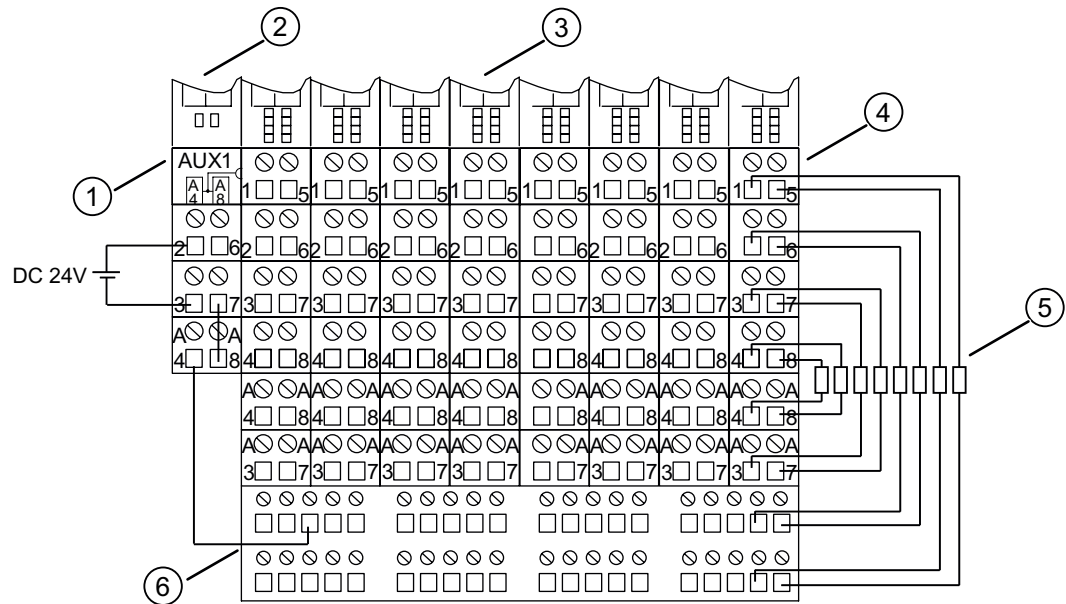

- ① Terminal module TM-P15S23-A0
- ② Power module PM-E 24 VDC
- ③ Electronic modules 8DI DC24V
- ④ Terminal modules TM-E15S26-A1
- ⑤ Actuators in 2-wire connection
- ⑥ Add-on terminal TE-U120S4x10

Block Diagram

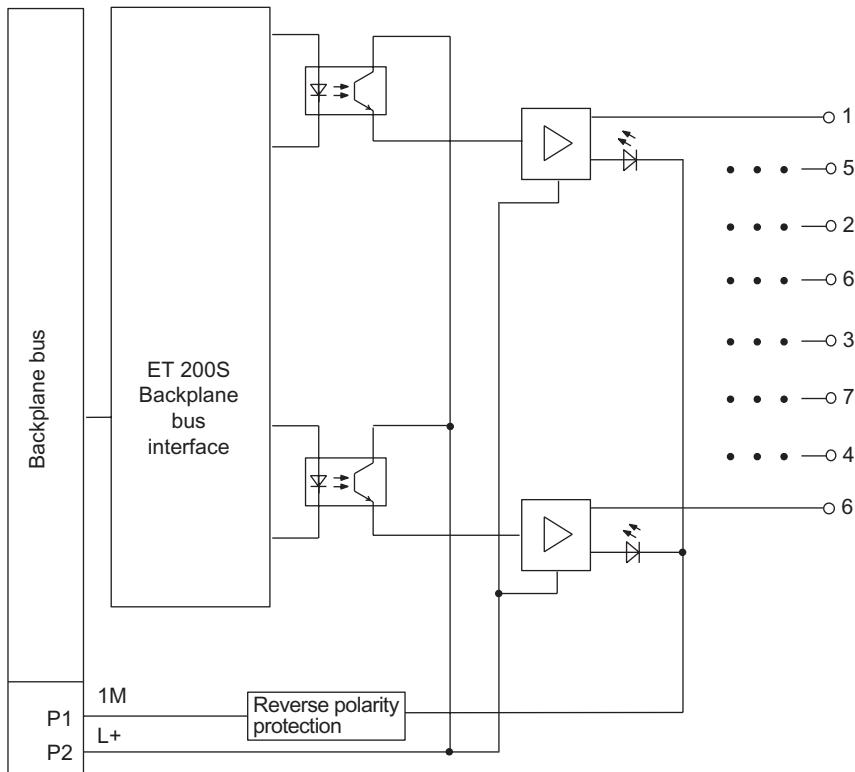

Figure 2-2 Block diagram of the 8 DO DC 24V/0.5A

Technical specifications 8DO DC24V/0.5A (6ES7132-4BF00-0AA0)

Dimensions and weight	
Dimensions W × H × D (mm) (the total dimensions depend on the selected terminal module)	15 × 81 × 52
Weight	Approx. 40 g
Module-specific data	
Supports isochronous operation	Yes
Number of outputs	8
Length of cable	
• Unshielded	600 m, maximum
• Shielded	1000 m, maximum
Parameter length	3 bytes



<b>Voltages, currents, potentials</b>	
Rated load voltage L+ (from the power module)	24 VDC
• Reverse polarity protection	Yes <sup>1</sup>
Total current of the outputs (per module)	4 A
Electrical isolation	
• Between the channels	No
• Between the channels and backplane bus	Yes
Permissible potential difference	
• Between the different circuits	75 VDC / 60 VAC
Insulation tested	500 VDC
Current consumption	
• From the rated load voltage L+ (no load)	Max. 5 mA per channel
Power dissipation of the module	Typically 1.5 W
<b>Status, interrupts, diagnostics</b>	
Status display	Green LED per channel
Diagnostics function	No
<b>Data for selecting an actuator</b>	
Output voltage	
• At signal "1"	Min. L+ (-1 V)
Output current	
• At signal "1"	
– Rated value	0.5 A
– Permitted range	7 mA to 0.6 A
• With signal "0" (leakage current)	0.3 mA max.
Output delay (for resistive load)	
• At "0" to "1"	max. 300 µs
• At "1" to "0"	max. 600 µs
Load resistor range	48 Ω to 3.4 kΩ
Lamp load	Max. 5 W
Connecting two outputs in parallel	
• For redundant triggering of a load	Yes (per module)
• To increase performance	No
Control of a digital input	Yes
Switch rate	
• For resistive load	100 Hz
• On inductive load	2 Hz
• For lamp load	10 Hz
Limitation (internal) of the voltage induced on circuit interruption	Typically L+ (-55 V to -60 V)
Reverse-voltage proof	Yes, if using the same load voltage as at the power module
Short-circuit protection of the output	Yes <sup>2</sup>
• Threshold on	Typically 1.5 A
<sup>1</sup> Polarity reversal can lead to the digital outputs being connected through.	
<sup>2</sup> Per channel	



# Index

## D

- Digital electronic module 8 DO DC 24V/0.5A
  - Block diagram, 2-10
  - Pin assignment, 2-7
  - Properties, 2-7
  - Technical specifications, 2-10
- Digital electronic module 8DI DC24V
  - Block diagram, 2-5

- Pin assignment, 2-2
- Properties, 2-2, 2-9
- Technical specifications, 2-6

## L

- LED display
  - 8DI DC24V, 2-1
  - 8DO DC24V 0.5A, 2-1

