

SINAMICS G120C compact inverters 0.55 kW to 18.5 kW (0.75 hp to 25 hp)

4







4/2	Introduction
4/2	Application
4/2	More information
4/3	SINAMICS G120C compact inverters
4/3	Overview
4/3	Benefits
4/3	Design
4/5	Integration
4/8	Configuration
4/9	Selection and ordering data
4/10	Technical specifications
4/17	Characteristic curves
4/18	Dimensional drawings
4/19	More information
4/20	Line-side components
4/20	Line reactors
4/21	Recommended line-side power components
4/22	DC link components
4/22	Braking resistors
4/23	Supplementary system components
4/23	Operator panels
4/24	Intelligent Operator Panel IOP
4/26	Basic Operator Panel BOP-2
4/27	Memory cards
4/27	PC inverter connection kit 2
4/28	Spare parts

SINAMICS G120C compact inverters

0.55 kW to 18.5 kW (0.75 hp to 25 hp)

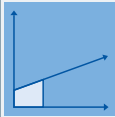
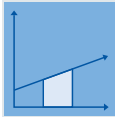
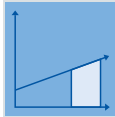
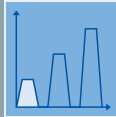
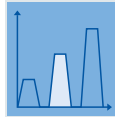
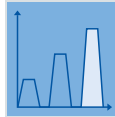
Introduction

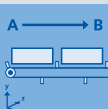
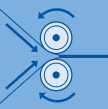
Application

Application	Continuous motion			Non-continuous motion		
	Basic	Medium	High	Basic	Medium	High
	Requirements for torque accuracy / speed accuracy / position accuracy / coordination of axes / functionality			Requirements for torque accuracy / speed accuracy / position accuracy / coordination of axes / functionality		
						
Pumping, ventilating, compressing	Centrifugal pumps Radial / axial fans Compressors	Centrifugal pumps Radial / axial fans Compressors	Eccentric screw pumps	Hydraulic pumps Metering pumps	Hydraulic pumps Metering pumps	Descaling pumps Hydraulic pumps
	G110, G120C (G130, G150, GM150, GL150)	G120P, G120C, G120 (G130, G150, GM150, GL150)	S120	S110	S110, S120	S120 (GM150)
Moving	Conveyor belts Roller conveyors Chain conveyors	Conveyor belts Roller conveyors Chain conveyors Lifting/lowering devices Elevators Escalators/moving walkways Indoor cranes Marine drives Cable railways	Elevators Container cranes Mining hoists Excavators for open-cast mining Test bays	Acceleration conveyors Storage and retrieval machines	Acceleration conveyors Storage and retrieval machines Cross cutters Reel changers	Storage and retrieval machines Robotics Pick & place Rotary indexing tables Cross cutters Roll feeds Engagers/disengagers
	G110, G110D, G120C (G130, G150, GM150)	G120D, G120C, G120, S120 (G130, G150, S150, GM150, GL150, SM150, DCM, SIMATIC ET200S, SIMATIC ET200pro)	S120 (S150, SM150, SL150, GM150, DCM)	S110	S110, S120 (DCM)	S120 (GM150)
Processing	Mills Mixers Kneaders Crushers Agitators Centrifuges	Mills Mixers Kneaders Crushers Agitators Centrifuges Extruders Rotary furnaces	Extruders Winders and unwinders Lead/follower drives Calenders Main press drives Printing machines	Tubular bagging machines Single-axis motion control such as • Position profile • Path profile	Tubular bagging machines Single-axis motion control such as • Position profile • Path profile	Servo presses Rolling mill drives Multi-axis motion control such as • Multi-axis positioning • Cams • Interpolations
	G120C (G130, G150, GM150)	G120C, G120 (G130, G150, S150, GM150, GL150, DCM)	S120 (S150, DCM)	S110	S110, S120	S120 (SM150, SL150, DCM)
Machining	Main drives for • Turning • Drilling • Milling	Main drives for • Drilling • Sawing	Main drives for • Turning • Drilling • Milling • Gear cutting • Grinding	Axle drives for • Turning • Drilling • Milling	Axle drives for • Drilling • Sawing	Axle drives for • Turning • Drilling • Milling • Lasering • Gear cutting • Grinding • Nibbling and punching
	S110	S110, S120	S120	S110	S110, S120	S120

(Devices in brackets are not included in Catalog D 31)

SINAMICS G120C compact inverters continuously control the speed of three-phase asynchronous (induction) motors and can be used in a wide range of industrial areas. They are generally

suitable for applications involving conveyor belts, mixers, extruders, pumps, fans, compressors and basic handling machines.

More information

You may also be interested in these inverters:

- More performance in the control cabinet in IP20 degree of protection ⇒ SINAMICS G120 ([chapter 6](#))
- Higher degree of protection for power ratings up to 7.5 kW ⇒ SINAMICS G110D ([chapter 7](#)), SINAMICS G120D ([chapter 8](#))
- With positioning function in the control cabinet in IP20 degree of protection ⇒ SINAMICS S110 ([chapter 9](#))

SINAMICS G120C compact inverters

0.55 kW to 18.5 kW (0.75 hp to 25 hp)

SINAMICS G120C compact inverters

Overview



SINAMICS G120C frame sizes FSA, FSB and FSC with mounted blanking cover

SINAMICS G120C compact inverters offer a well-balanced combination of features to address a wide range of applications. SINAMICS G120C inverters are compact, rugged devices that are easy to operate and can be optionally equipped with a basic or advanced operator panel.

SINAMICS G120C inverters are especially suitable when it comes to meeting the requirements of system integrators, OEMs and distributors regarding high productivity and tailored performance.

Benefits

- Compact design
- Side-by-side design
- High power density, low envelope dimensions
- Simple installation in the tightest space
- Low space requirement
- Use in small control cabinets, close to the machine
- Optimized parameter set
- Optimized commissioning
- Getting Started document
- BOP-2 or IOP operator panels can be used
- Integrated USB connection
- Simple and fast software parameter assignment
- Simple to use during commissioning and in operation
- Minimized training costs, existing SINAMICS know-how can be used
- High degree of service friendliness, simple maintenance
- Plug-in terminals
- Cloning function using BOP-2 or SD card
- Operating hours counter for "drive on" and "motor on"
- Fast mechanical installation
- Intuitive standard commissioning
- Integrated component of Totally Integrated Automation
- Energy-efficient, sensorless vector control
- Automatic flux reduction with V/f ECO
- Integrated energy saving computer
- Safety Integrated (STO)
- Integrated communication interfaces PROFIBUS DP, CAN, USS, Modbus RTU
- Coated modules
- Operation up to an ambient temperature of 60° C (140 °F)

Design

SINAMICS G120C is a compact inverter in IP20 degree of protection where the Control Unit (CU) and Power Module (PM) function units are combined in one device.

The compact mechanical design and the high power density allow these devices to be installed in machine control enclosures and control cabinets for maximum space utilization. SINAMICS G120C compact inverters can be lined up next to one another without requiring any derating.



SINAMICS G120C, frame size FSB, with BOP-2

SINAMICS G120C can be integrated into the widest range of applications, either using the integrated digital and analog inputs or via the integrated fieldbus interface (available in the USS/Modbus RTU, PROFIBUS DP, CANopen versions). Especially the product versions with integrated PROFIBUS-DP interface make full integration into the Siemens TIA family possible, therefore allowing the advantages of the seamless TIA product family to be fully utilized. SINAMICS G120C devices are preset in the factory so that they can be immediately connected to PROFIBUS DP and CANopen fieldbuses and used without parameterization.

SINAMICS G120C is also equipped with the safety function STO (Safe Torque Off) as standard, which is used to safely stop drives. As a consequence, machine manufacturers can simply comply with current machinery directives with minimum associated costs.

SINAMICS G120C can control asynchronous (induction) motors in the power range from 0.37 kW up to 18.5 kW (0.5 hp up to 25 hp). Reliable and efficient motor operation is achieved by using state-of-the-art IGBT technology combined with vector control. The extensive range of functions integrated in the SINAMICS G120C also offers a high degree of protection for the inverter and motor.

SINAMICS G120C compact inverters

0.55 kW to 18.5 kW (0.75 hp to 25 hp)

SINAMICS G120C compact inverters

Design

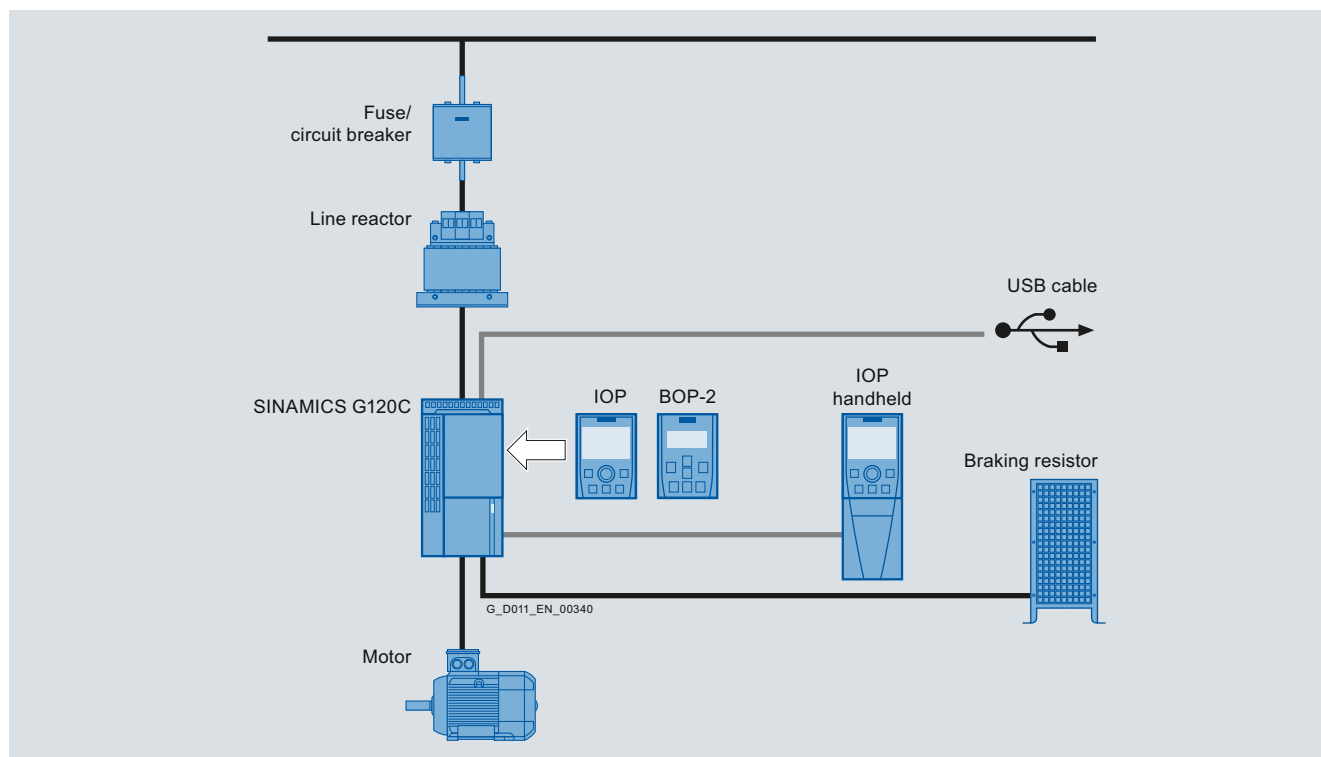

Line-side components

Line reactors

A line reactor is used to smooth voltage peaks (inverter protection) and to reduce commutating dips (line harmonic distortion).

Recommended line-side power components

Standard fuses can be used for the SINAMICS G120C. These must be dimensioned to comply with local regulations. In this chapter, you will find recommended components such as fuses and circuit breakers in compliance with IEC and UL regulations.

DC link components

Braking resistors

The excess energy of the DC link is dissipated using the braking resistor. The braking resistors are designed for use with the SINAMICS G120C. This has an integrated brake chopper (electronic switch).

Supplementary system components

Intelligent Operator Panel IOP

Graphics-based, user-friendly and powerful operator panel for commissioning and diagnostics as well as local operator control and monitoring of SINAMICS G120C.

Basic Operator Panel BOP-2

A 2-line display to provide support when commissioning and troubleshooting the drive. The drive can be locally controlled.

Memory cards

The parameter settings for an inverter can be stored on the SINAMICS micro memory card (MMC) or SIMATIC memory card (SD card). When service is required, e.g. after the inverter has been replaced and the data have been downloaded from the memory card the drive system is immediately ready for use again. The associated memory card holder is integrated in the inverter.

PC inverter connection kit 2

For controlling and commissioning an inverter directly from a PC, if the STARTER commissioning tool V4.2 and higher has been installed on the PC.

Spare parts

Shield plates

A set of shield plates can be ordered for the motor and signal lines corresponding to the frame size of the SINAMICS G120C inverter.

Spare Parts Kit

This kit comprises 5 sets of I/O terminals, 1 RS485 terminal, 2 Control Unit doors and 1 blanking cover.

Set of connectors

A set of connectors for the line feeder cable, braking resistor and motor cable can be ordered corresponding to the frame size of the SINAMICS G120C inverter.

Roof-mounted fan

A roof-mounted fan (at the top of the device) comprising a pre-assembled unit with holder and fan can be ordered corresponding to the frame size of the SINAMICS G120C.

Fan unit

A replacement fan (at the rear of the device; heat sink) comprising a pre-assembled unit with holder and fan can be ordered corresponding to the frame size of the SINAMICS G120C.

SINAMICS G120C compact inverters

0.55 kW to 18.5 kW (0.75 hp to 25 hp)

SINAMICS G120C compact inverters

Integration

4

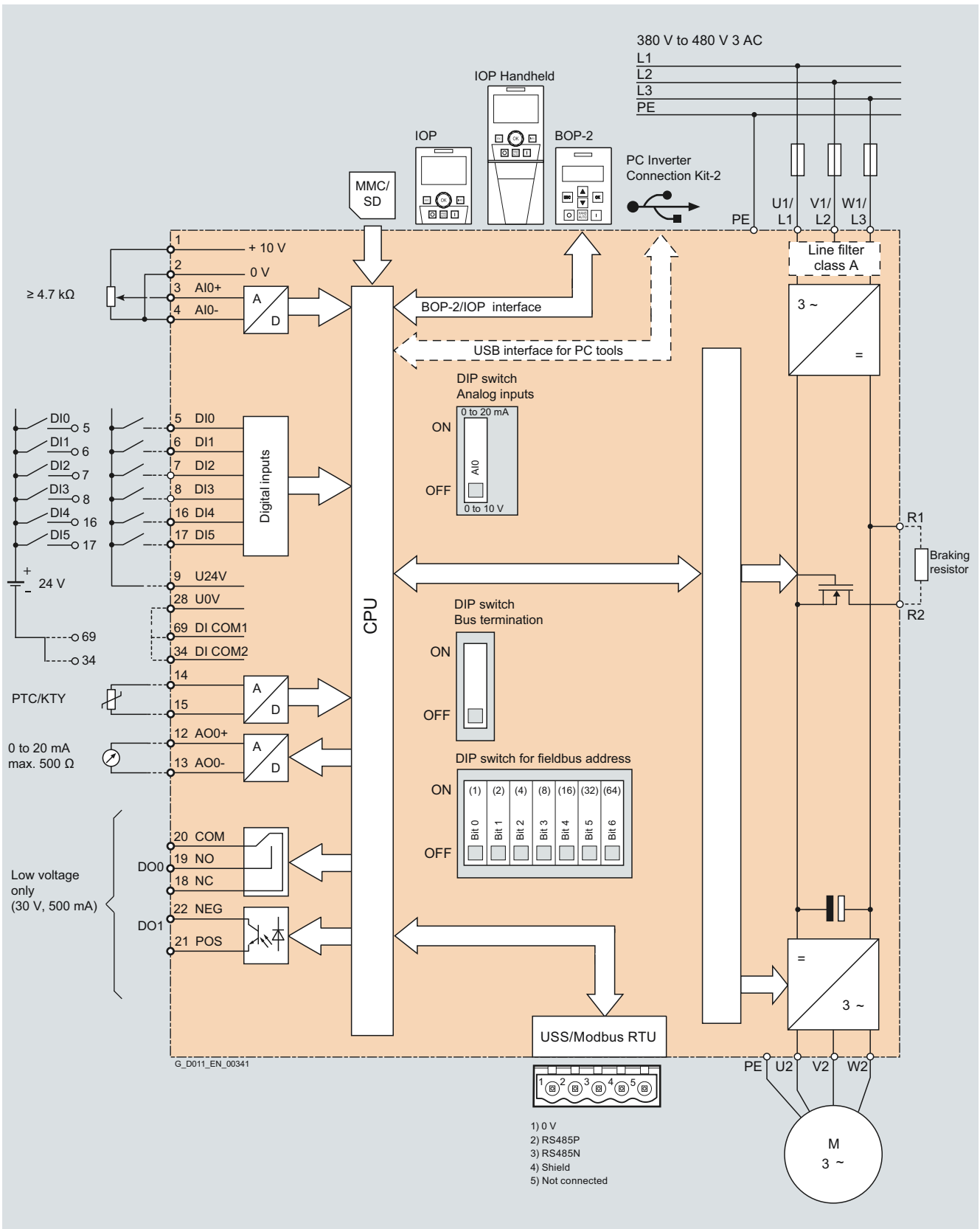

Connection example SINAMICS G120C, USS/Modbus RTU version

SINAMICS G120C compact inverters

0.55 kW to 18.5 kW (0.75 hp to 25 hp)

SINAMICS G120C compact inverters

Integration

4

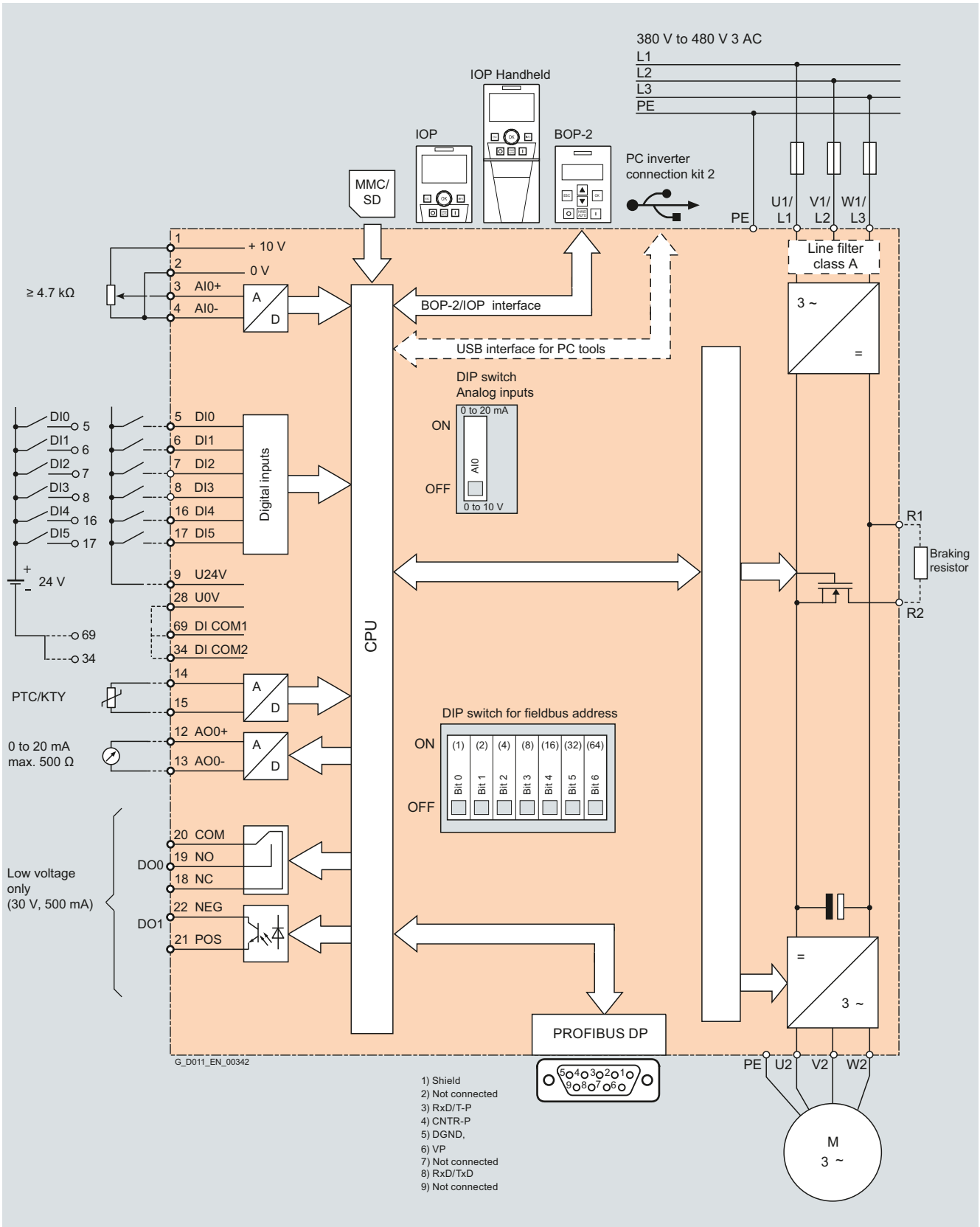

Connection example SINAMICS G120C, PROFIBUS DP version

SINAMICS G120C compact inverters

0.55 kW to 18.5 kW (0.75 hp to 25 hp)

SINAMICS G120C compact inverters

Integration

4

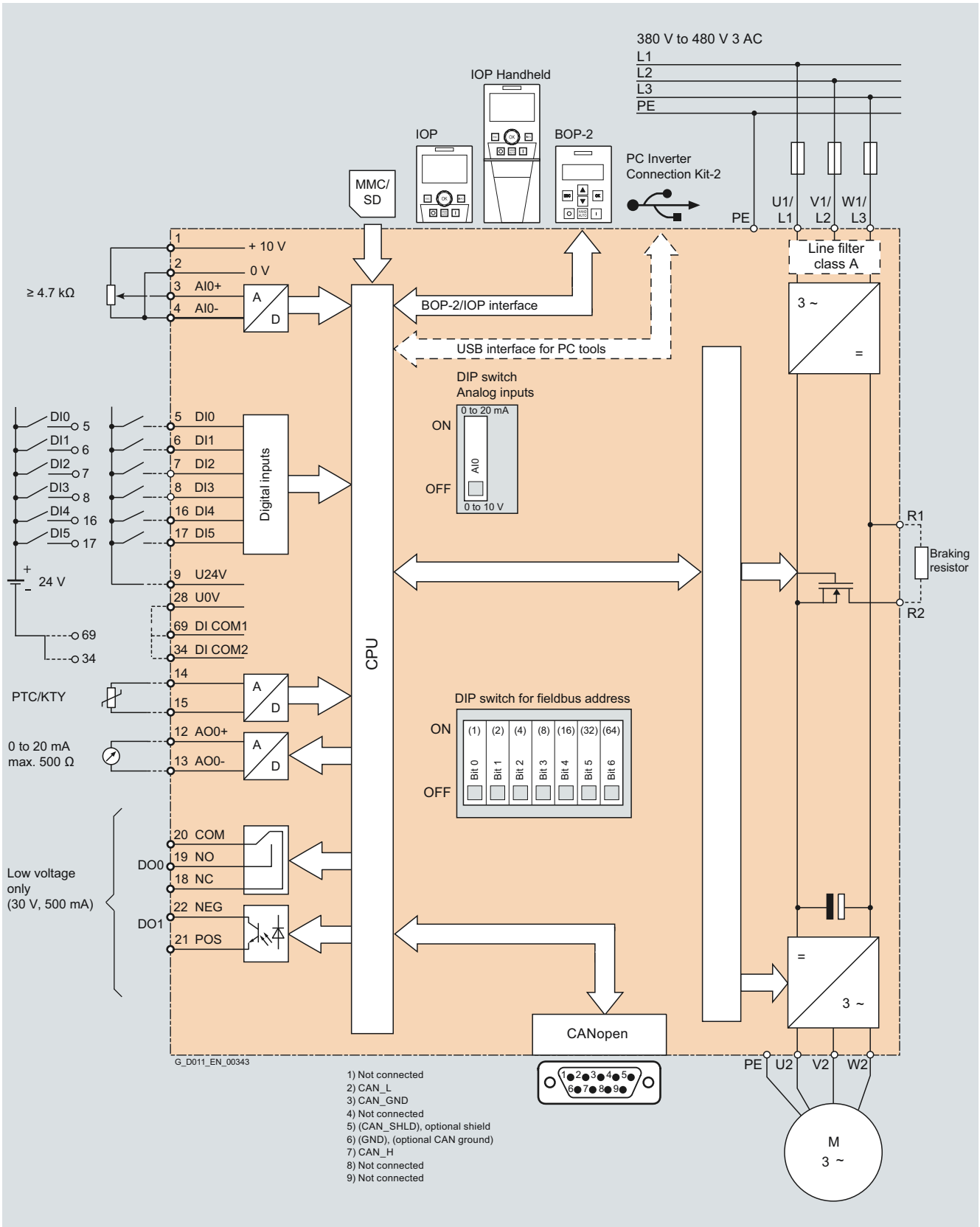

Connection example SINAMICS G120C, CANopen version

SINAMICS G120C compact inverters

0.55 kW to 18.5 kW (0.75 hp to 25 hp)

SINAMICS G120C compact inverters

Configuration

The following electronic configuring guides and engineering tools are available for SINAMICS G120C compact inverters:

Selection guide DT Configurator within the CA 01

The interactive catalog CA 01 – the offline mall of Siemens Industry Automation & Drive Technologies – contains over 100000 products with approximately 5 million possible drive system product variants. The DT Configurator has been developed to facilitate selection of the optimum motor and/or inverter from the wide spectrum of drives. The configurator is integrated as a "selection guide" in this catalog on the DVD-ROM with the selection and configuration tools.

Online DT Configurator

In addition, the DT Configurator can be used in the Internet without requiring any installation. The DT Configurator can be found in the Siemens Industry Mall at the following address: www.siemens.com/dt-configurator

SIZER for Siemens Drives engineering tool

The SIZER for Siemens Drives engineering tool makes it easy to engineer the SINAMICS and MICROMASTER 4 drive families. It provides support when selecting the hardware and firmware components necessary to implement a drive task. SIZER for Siemens Drives covers the full range of operations required to configure a complete drive system, from basic single drives to demanding multi-axis applications.

[Additional information on the SIZER for Siemens Drives engineering tool is provided in the chapter Engineering tools.](#)

STARTER commissioning tool

The STARTER commissioning tool allows menu-prompted commissioning, optimization and diagnostics. In addition to SINAMICS drives, STARTER is also suitable for MICROMASTER 4 units and the frequency converters for the distributed I/O SIMATIC ET 200S FC and SIMATIC ET 200pro FC. For SINAMICS G120D from STARTER version 4.1, SP1 and higher.

[Additional information on the STARTER commissioning tool is provided in the chapter Engineering tools.](#)

Drive ES engineering system

Drive ES is the engineering system used to integrate the communication, configuration and data management functions of Siemens drive technology into the SIMATIC automation world easily, efficiently and cost-effectively. The STEP 7 Manager user interface provides the ideal basis for this. A variety of software packages are available for SINAMICS – Drive ES Basic, Drive ES SIMATIC and Drive ES PCS 7.1.

[Additional information on the Drive ES engineering system is provided in the chapter Engineering tools.](#)

SINAMICS G120C compact inverters

0.55 kW to 18.5 kW (0.75 hp to 25 hp)

SINAMICS G120C compact inverters

Selection and ordering data

The order number is selected corresponding to

- the required motor power or the motor current required and the overload requirements of the application,
- the necessary EMC classification and
- the required integrated fieldbus interface

Rated power ¹⁾		Base load current I_L ²⁾	Base load current I_H ³⁾	Frame size	Version	SINAMICS G120C without filter	SINAMICS G120C with integrated filter class A
kW	hp	A	A			Order No.	Order No.
0.55	0.75	1.7	1.3	FSA	USS/Modbus RTU	6SL3210-1KE11-8UB0	6SL3210-1KE11-8AB0
					PROFIBUS DP	6SL3210-1KE11-8UP0	6SL3210-1KE11-8AP0
					CANopen	6SL3210-1KE11-8UC0	6SL3210-1KE11-8AC0
0.75	1.0	2.2	1.7	FSA	USS/Modbus RTU	6SL3210-1KE12-3UB0	6SL3210-1KE12-3AB0
					PROFIBUS DP	6SL3210-1KE12-3UP0	6SL3210-1KE12-3AP0
					CANopen	6SL3210-1KE12-3UC0	6SL3210-1KE12-3AC0
1.1	1.5	3.1	2.2	FSA	USS/Modbus RTU	6SL3210-1KE13-2UB0	6SL3210-1KE13-2AB0
					PROFIBUS DP	6SL3210-1KE13-2UP0	6SL3210-1KE13-2AP0
					CANopen	6SL3210-1KE13-2UC0	6SL3210-1KE13-2AC0
1.5	2.0	4.1	3.1	FSA	USS/Modbus RTU	6SL3210-1KE14-3UB0	6SL3210-1KE14-3AB0
					PROFIBUS DP	6SL3210-1KE14-3UP0	6SL3210-1KE14-3AP0
					CANopen	6SL3210-1KE14-3UC0	6SL3210-1KE14-3AC0
2.2	3.0	5.6	4.1	FSA	USS/Modbus RTU	6SL3210-1KE15-8UB0	6SL3210-1KE15-8AB0
					PROFIBUS DP	6SL3210-1KE15-8UP0	6SL3210-1KE15-8AP0
					CANopen	6SL3210-1KE15-8UC0	6SL3210-1KE15-8AC0
3.0	4.0	7.3	5.6	FSA	USS/Modbus RTU	6SL3210-1KE17-5UB0	6SL3210-1KE17-5AB0
					PROFIBUS DP	6SL3210-1KE17-5UP0	6SL3210-1KE17-5AP0
					CANopen	6SL3210-1KE17-5UC0	6SL3210-1KE17-5AC0
4.0	5.0	8.8	7.3	FSA	USS/Modbus RTU	6SL3210-1KE18-8UB0	6SL3210-1KE18-8AB0
					PROFIBUS DP	6SL3210-1KE18-8UP0	6SL3210-1KE18-8AP0
					CANopen	6SL3210-1KE18-8UC0	6SL3210-1KE18-8AC0
5.5	7.5	12.5	8.8	FSB	USS/Modbus RTU	6SL3210-1KE21-3UB0	6SL3210-1KE21-3AB0
					PROFIBUS DP	6SL3210-1KE21-3UP0	6SL3210-1KE21-3AP0
					CANopen	6SL3210-1KE21-3UC0	6SL3210-1KE21-3AC0
7.5	10	16.5	12.5	FSB	USS/Modbus RTU	6SL3210-1KE21-7UB0	6SL3210-1KE21-7AB0
					PROFIBUS DP	6SL3210-1KE21-7UP0	6SL3210-1KE21-7AP0
					CANopen	6SL3210-1KE21-7UC0	6SL3210-1KE21-7AC0
11	15	25	16.5	FSC	USS/Modbus RTU	6SL3210-1KE22-6UB0	6SL3210-1KE22-6AB0
					PROFIBUS DP	6SL3210-1KE22-6UP0	6SL3210-1KE22-6AP0
					CANopen	6SL3210-1KE22-6UC0	6SL3210-1KE22-6AC0
15	20	31	25	FSC	USS/Modbus RTU	6SL3210-1KE23-2UB0	6SL3210-1KE23-2AB0
					PROFIBUS DP	6SL3210-1KE23-2UP0	6SL3210-1KE23-2AP0
					CANopen	6SL3210-1KE23-2UC0	6SL3210-1KE23-2AC0
18.5	25	37	31	FSC	USS/Modbus RTU	6SL3210-1KE23-8UB0	6SL3210-1KE23-8AB0
					PROFIBUS DP	6SL3210-1KE23-8UP0	6SL3210-1KE23-8AP0
					CANopen	6SL3210-1KE23-8UC0	6SL3210-1KE23-8AC0

¹⁾ The rated power of the device based on the rated output current I_{LO} and a rated input voltage of 400 V 3 AC. The rated power is specified on the device rating plate.

²⁾ The base load current I_L is based on the duty cycle for low overload (LO). The current value is specified on the device rating plate.

³⁾ The base load current I_H is based on the duty cycle for high overload (HO). The current value is not specified on the device rating plate.

SINAMICS G120C compact inverters

0.55 kW to 18.5 kW (0.75 hp to 25 hp)

SINAMICS G120C compact inverters

Technical specifications

Unless explicitly specified otherwise, the following technical specifications are valid for all SINAMICS G120C compact inverters.

Mechanical specifications	
Vibratory load According to EN 60068-2-6	
<ul style="list-style-type: none"> Transport in the transport packaging Operation 	5 ... 9 Hz: Constant deflection 3.1 mm 9 ... 200 Hz: Constant acceleration = 9.81 m/s ² (1 × g) 2 ... 9 Hz: Constant deflection 7 mm 9 ... 200 Hz: Constant acceleration = 19.62 m/s ² (2 × g)
Shock load According to EN 60068-2-27	
<ul style="list-style-type: none"> Transport in the transport packaging Operation 	147.15 m/s ² (15 × g)/11 ms 3 shocks in each axis and direction 147.15 m/s ² (15 × g)/11 ms 3 shocks in each axis and direction
Degree of protection	IP20/ UL open type
Permissible mounting position	Horizontal panel mounting
Ambient conditions	
Protection class According to EN 61800-5-1	Class III (PELV1)
Touch protection According to EN 61800-5-1	Class I (with protective conductor system)
Humidity, max.	95 % at 40 °C (104 °F), condensation and icing not permissible
Ambient temperature	
<ul style="list-style-type: none"> Storage ¹⁾ acc. to EN 60068-2-1 Transport ¹⁾ acc. to EN 60068-2-1 Operation acc. to EN 60068-2-2 	-40 ... +70 °C (-40 ... +158 °F) -40 ... +70 °C (-40 ... +158 °F) 0 ... 40 °C (32 ... 104 °F) without derating >40 ... 60 °C (104 ... 140 °F) see derating characteristics
Environmental class in operation	
<ul style="list-style-type: none"> Harmful chemical substances Organic/biological pollutants Degree of pollution 	Class 3C2 to EN 60721-3-3 Class 3B1 to EN 60721-3-3 2 acc. to EN 61800
Standards	
Compliance with standards	CE, cULus, c-tick
Fail-safe certification	Function: Safe Torque Off (STO) SIL 2 according to IEC 61508, Parts 1 to 7 (1998 ... 2001) PL d according to EN ISO 13849 Part 1 (2008) Category 3 according to EN 60204 (2007) PFH _D : 5 × 10E-8 / T1: 10 years
CE marking, according to	EMC Directive 2004/108/EC Low-Voltage Directive 2006/95/EC
EMC behavior According to EN 61800-3	The EMC product standard EN 61800-3 does not apply directly to a frequency inverter but to a PDS (Power Drive System), which comprises the complete circuitry, motor and cables in addition to the inverter.
<ul style="list-style-type: none"> Frame sizes FSA to FSB with integrated line filter class A Frame size FSC with integrated line filter class A 	Category C2 with max. 25 m (82 ft) shielded motor cable Category C3 with max. 25 m (82 ft) shielded motor cable

¹⁾ In transport packaging.

SINAMICS G120C compact inverters

0.55 kW to 18.5 kW (0.75 hp to 25 hp)

SINAMICS G120C compact inverters

Technical specifications

Control Unit	USS/Modbus RTU version	PROFIBUS DP version	CANopen version
	6SL3210-0KE...-B0	6SL3210-0KE...-P0	6SL3210-0KE...-C0
I/O interfaces			
Signal cable cross-section	0.15 mm ² ... 1.5 mm ² (AWG28 ... AWG16)		
Digital inputs – Standard	6 isolated inputs Optically isolated; Free reference potential (own potential group) NPN/PNP logic can be selected using the wiring		
• Switching level: 0 → 1	11 V		
• Switching level: 1 → 0	5 V		
• Input current, max.	15 mA		
Fail-safe input	1 safety input When using the standard digital inputs (DI4+DI5) Safety function: Safe Torque OFF (STO)		
Digital outputs	1 relay changeover contact 30 V DC, 0.5 A (ohmic load) 1 transistor 30 V DC, 0.5 A (ohmic load)		
Analog inputs	1 analog input Differential input Switchable between voltage (-10 ... +10 V) and current (0/4 ... 20 mA) using a DIP switch 10-bit resolution Can be used as additional digital input Analog inputs are protected in a voltage range of ± 30 V and have a common-mode voltage in the ± 15 V range.		
• Switching threshold: 0 → 1	4 V		
• Switching threshold: 1 → 0	1.6 V		
Analog outputs	1 analog output Non-isolated output Switchable between voltage (0 ... 10 V) and current (0/4 ... 20 mA) using a parameter Voltage mode: 10 V, min. burden 10 kΩ Current mode: 20 mA, max. burden 500 Ω The analog outputs have short circuit protection		
PTC/KTY interface	1 motor temperature sensor input sensors that can be connected: PTC, KTY and Thermo-Click, Accuracy ±5 °C		
Integrated bus interface			
Type	RS485	PROFIBUS DP	CANopen
Protocols	USS Modbus RTU (switchable using a parameter)	PROFIdrive Profile V4.1	CANopen
Hardware	Plug-in terminal, insulated, USS: max. 187.5 kbaud Modbus RTU: 19.2 kbaud, Bus terminating resistors that can be switched in	9-pin SUB-D connector, insulated, Max. 12 Mbit/s Slave address can be set using DIP switches	9-pin SUB-D socket, insulated, Max. 1 Mbit/s
Tool interfaces			
Memory cards	Optional 1 SINAMICS micro memory card (MMC) or 1 SIMATIC memory card (SD card)		
Operator panels	Optional Basic Operator Panel BOP-2 or Intelligent Operator Panel IOP		
PC interface	USB		

SINAMICS G120C compact inverters

0.55 kW to 18.5 kW (0.75 hp to 25 hp)

SINAMICS G120C compact inverters

Technical specifications

Control Unit	USS/Modbus RTU version	PROFIBUS DP version	CANopen version
	6SL3210-0KE...-B0	6SL3210-0KE...-P0	6SL3210-0KE...-C0
Open-loop/closed-loop control techniques			
V/f linear/square/ parameterizable	✓		
V/f with flux current control (FCC)	✓		
V/f ECO linear/square	✓		
Vector control, sensorless	✓		
Vector control, with sensor	–		
Torque control, sensorless	–		
Torque control, with sensor	–		
Software functions			
Setpoint input	✓		
Fixed frequencies	16, parameterizable		
JOG	✓		
Digital motorized potentiometer (MOP)	✓		
Ramp smoothing	✓		
Extended ramp-function generator (with ramp smooth- ing Off3)	✓		
Positioning down ramp	–		
Slip compensation	✓		
Signal interconnection with BICO technology	✓		
Free function blocks (FFB) for logical and arithmetic operations	–		
Switchable drive data sets (DDS)	–		
Switchable command data sets (CDS)	✓ (2)		
Flying restart	✓		
Automatic restart after line supply failure or operating fault (AR)	✓		
Technology controller (internal PID)	✓		
Energy consumption counter	✓		
Energy saving computer	✓		
Thermal motor protection	✓ (I^2t , sensor: PTC/KTY/Thermo-Click)		
Thermal inverter protection	✓		
Motor identification	✓		
Motor holding brake	✓		
Auto-ramping (V_{dmax} controller)	✓		
Kinetic buffering (V_{dmin} controller)	✓		
Braking functions			
• DC braking	✓		
• Compound braking	✓		
• Dynamic braking with integrated brake chopper	✓		

SINAMICS G120C compact inverters

0.55 kW to 18.5 kW (0.75 hp to 25 hp)

SINAMICS G120C compact inverters

Technical specifications

General technical specifications of the power electronics

System operating voltage	380 ... 480 V 3 AC +10 % -20 %
Line supply requirements	No restriction
Line short circuit voltage u_K	
Input frequency	47 ... 63 Hz
Output frequency	
• Control type V/f	0 ... 650 Hz
• Control type Vector	0 ... 240 Hz
Pulse frequency	4 kHz for higher pulse frequencies up to 16 kHz, see derating data
Power factor λ	0.7 ... 0.85
Offset factor $\cos \varphi$	≥ 0.95
Output voltage, max.	0 ... 95 % of input voltage
Overload capability	
• Low overload (LO)	150 % base load current I_L for 3 s, followed by 110 % base load current I_L for 57 s followed by 100 % base load current I_L for 240 s in a 300 s cycle time
• High overload (HO)	200 % base load current I_H for 3 s, followed by 150 % base load current I_H for 57 s followed by 100 % base load current I_L for 240 s in a 300 s cycle time
Electromagnetic compatibility	With integrated line filter Category C2/C3 according to EN 61800-3
Cooling	Air cooling using an integrated fan
Installation altitude	Up to 1000 m (3281 ft) above sea level without derating, > 1000 m (3281 ft) see derating characteristics
Standard SCCR (Short Circuit Current Rating) ¹⁾	65 kA
Protection functions	<ul style="list-style-type: none"> • Undervoltage • Overvoltage • Overcontrol/overload • Ground fault • Short-circuit • Stall protection • Motor blocking protection • Motor overtemperature • Inverter overtemperature

¹⁾ Applies to industrial control cabinet installations to NEC article 409/UL 508A.

SINAMICS G120C compact inverters

0.55 kW to 18.5 kW (0.75 hp to 25 hp)

SINAMICS G120C compact inverters

Technical specifications

Line voltage 380 ... 480 V 3 AC		SINAMICS G120C power electronics			
		6SL3210-1KE11-8..0	6SL3210-1KE12-3..0	6SL3210-1KE13-2..0	6SL3210-1KE14-3..0
Output current at 400 V 3 AC					
• Rated current $I_{rated}^{1)}$	A	1.8	2.3	3.2	4.3
• Base load current $I_L^{2)}$	A	1.7	2.2	3.1	4.1
• Base load current $I_H^{3)}$	A	1.3	1.7	2.2	3.1
• I_{max}	A	2.6	3.4	4.4	6.2
Rated power					
• Based on I_L	kW (hp)	0.55 (0.75)	0.75 (1.0)	1.1 (1.5)	1.5 (2.0)
• Based on I_H	kW (hp)	0.37 (0.5)	0.55 (0.75)	0.75 (1.0)	1.1 (1.5)
Rated pulse frequency	kHz	4	4	4	4
Efficiency η		0.97	0.97	0.97	0.97
Power loss at rated current	kW	0.04	0.05	0.05	0.07
Cooling air requirement	m^3/s (ft^3/s)	0.005 (0.18)	0.005 (0.18)	0.005 (0.18)	0.005 (0.18)
Sound pressure level L_{pA} (1 m)	dB	<52	<52	<52	<52
Rated input current $I_L^{4)}$					
• Based on I_L	A	2.3	2.9	4.1	5.5
• Based on I_H	A	1.9	2.5	3.2	4.5
Length of cable to braking resistor, max.	m (ft)	15 (49)	15 (49)	15 (49)	15 (49)
Line supply connection U1/L1, V1/L2, W1/L3		Plug-in screw terminals	Plug-in screw terminals	Plug-in screw terminals	Plug-in screw terminals
• Conductor cross-section	mm^2	1 ... 2.5 (16 ... 14 AWG)	1 ... 2.5 (16 ... 14 AWG)	1 ... 2.5 (16 ... 14 AWG)	1 ... 2.5 (16 ... 14 AWG)
Motor connection U2, V2, W2		Plug-in screw terminals	Plug-in screw terminals	Plug-in screw terminals	Plug-in screw terminals
• Conductor cross-section	mm^2	1 ... 2.5 (16 ... 14 AWG)	1 ... 2.5 (16 ... 14 AWG)	1 ... 2.5 (16 ... 14 AWG)	1 ... 2.5 (16 ... 14 AWG)
Connection for braking resistor R1, R2		Plug-in screw terminals	Plug-in screw terminals	Plug-in screw terminals	Plug-in screw terminals
• Conductor cross-section	mm^2	1 ... 2.5 (16 ... 14 AWG)	1 ... 2.5 (16 ... 14 AWG)	1 ... 2.5 (16 ... 14 AWG)	1 ... 2.5 (16 ... 14 AWG)
PE connection		On housing with M4 screw	On housing with M4 screw	On housing with M4 screw	On housing with M4 screw
Motor cable length, max.⁵⁾					
• Shielded	m (ft)	50 (164)	50 (164)	50 (164)	50 (164)
• Unshielded	m (ft)	100 (328)	100 (328)	100 (328)	100 (328)
Dimensions					
• Width	mm (in)	73 (2.87)	73 (2.87)	73 (2.87)	73 (2.87)
• Height	mm (in)	196 (7.72)	196 (7.72)	196 (7.72)	196 (7.72)
• Depth					
- Without operator panel	mm (in)	203 (7.99)	203 (7.99)	203 (7.99)	203 (7.99)
- With operator panel	mm (in)	224 (8.82)	224 (8.82)	224 (8.82)	224 (8.82)
Frame size		FSA	FSA	FSA	FSA
Weight, approx.	kg (lb)	1.7 (3.75)	1.7 (3.75)	1.7 (3.75)	1.7 (3.75)

¹⁾ The rated output current I_{rated} can be used up to 100 %; however, without overload.

²⁾ The base load current I_L is based on the duty cycle for low overload (LO).

³⁾ The base load current I_H is based on the duty cycle for high overload (HO).

⁴⁾ The rated input currents are valid for an input voltage of 400 V 3 AC and a line impedance corresponding to $u_K = 1\%$ (without line reactor). The rated input current based on I_L is stamped on the inverter rating plate. In the particular application, the input current depends on the motor load and line impedance. The input current is reduced when using a line reactor.

⁵⁾ The maximum motor cable lengths are valid for an input voltage of 400 V 3 AC and operation with a 4 kHz pulse frequency. To maintain limit values according to EN 61800-3 Category C2, a maximum motor cable length of 25 m (82 ft) (shielded) is permissible.

SINAMICS G120C compact inverters

0.55 kW to 18.5 kW (0.75 hp to 25 hp)

SINAMICS G120C compact inverters

Technical specifications

Line voltage 380 ... 480 V 3 AC		SINAMICS G120C power electronics			
		6SL3210-1KE15-8..0	6SL3210-1KE17-5..0	6SL3210-1KE18-8..0	6SL3210-1KE21-3..0
Output current at 400 V 3 AC					
• Rated current $I_{rated}^{1)}$	A	5.8	7.5	9.0	13.0
• Base load current $I_L^{2)}$	A	5.6	7.3	8.8	12.5
• Base load current $I_H^{3)}$	A	4.1	5.6	7.3	8.8
• I_{max}	A	8.2	11.2	14.6	17.6
Rated power					
• Based on I_L	kW (hp)	2.2 (3.0)	3.0 (4.0)	4.0 (5.0)	5.5 (7.5)
• Based on I_H	kW (hp)	1.5 (2.0)	2.2 (3.0)	3.0 (4.0)	4.0 (5.0)
Rated pulse frequency	kHz	4	4	4	4
Efficiency η		0.97	0.97	0.97	0.97
Power loss at rated current	kW	0.09	0.14	0.15	0.18
Cooling air requirement	m^3/s (ft^3/s)	0.005 (0.18)	0.005 (0.18)	0.005 (0.18)	0.009 (0.32)
Sound pressure level L_{pA} (1 m)	dB	<52	<52	<52	<63
Rated input current $I_L^{4)}$					
• Based on I_L	A	7.4	9.5	11.4	16.5
• Based on I_H	A	6.0	8.2	10.6	12.8
Length of cable to braking resistor, max.	m (ft)	15 (49)	15 (49)	15 (49)	15 (49)
Line supply connection U1/L1, V1/L2, W1/L3		Plug-in screw terminals	Plug-in screw terminals	Plug-in screw terminals	Plug-in screw terminals
• Conductor cross-section	mm^2	1 ... 2.5 (16 ... 14 AWG)	1 ... 2.5 (16 ... 14 AWG)	1 ... 2.5 (16 ... 14 AWG)	4 ... 6 (12 ... 10 AWG)
Motor connection U2, V2, W2		Plug-in screw terminals	Plug-in screw terminals	Plug-in screw terminals	Plug-in screw terminals
• Conductor cross-section	mm^2	1 ... 2.5 (16 ... 14 AWG)	1 ... 2.5 (16 ... 14 AWG)	1 ... 2.5 (16 ... 14 AWG)	4 ... 6 (12 ... 10 AWG)
Connection for braking resistor R1, R2		Plug-in screw terminals	Plug-in screw terminals	Plug-in screw terminals	Plug-in screw terminals
• Conductor cross-section	mm^2	1 ... 2.5 (16 ... 14 AWG)	1 ... 2.5 (16 ... 14 AWG)	1 ... 2.5 (16 ... 14 AWG)	4 ... 6 (12 ... 10 AWG)
PE connection		On housing with M4 screw	On housing with M4 screw	On housing with M4 screw	On housing with M4 screw
Motor cable length, max.⁵⁾					
• Shielded	m (ft)	50 (164)	50 (164)	50 (164)	50 (164)
• Unshielded	m (ft)	100 (328)	100 (328)	100 (328)	100 (328)
Dimensions					
• Width	mm (in)	73 (2.87)	73 (2.87)	73 (2.87)	100 (3.94)
• Height	mm (in)	196 (7.72)	196 (7.72)	196 (7.72)	196 (7.72)
• Depth					
- Without operator panel	mm (in)	203 (7.99)	203 (7.99)	203 (7.99)	203 (7.99)
- With operator panel	mm (in)	224 (8.82)	224 (8.82)	224 (8.82)	224 (8.82)
Frame size		FSA	FSA	FSA	FSB
Weight, approx.	kg (lb)	1.7 (3.75)	1.7 (3.75)	1.7 (3.75)	2.3 (5)

¹⁾ The rated output current I_{rated} can be used up to 100 %; however, without overload.

²⁾ The base load current I_L is based on the duty cycle for low overload (LO).

³⁾ The base load current I_H is based on the duty cycle for high overload (HO).

⁴⁾ The rated input currents are valid for an input voltage of 400 V 3 AC and a line impedance corresponding to $u_K = 1\%$ (without line reactor). The rated input current based on I_L is stamped on the inverter rating plate. In the particular application, the input current depends on the motor load and line impedance. The input current is reduced when using a line reactor.

⁵⁾ The maximum motor cable lengths are valid for an input voltage of 400 V 3 AC and operation with a 4 kHz pulse frequency. To maintain limit values according to EN 61800-3 Category C2, a maximum motor cable length of 25 m (82 ft) (shielded) is permissible.

SINAMICS G120C compact inverters

0.55 kW to 18.5 kW (0.75 hp to 25 hp)

SINAMICS G120C compact inverters

Technical specifications

Line voltage 380 ... 480 V 3 AC		SINAMICS G120C power electronics			
		6SL3210-1KE21-7..0	6SL3210-1KE22-6..0	6SL3210-1KE23-2..0	6SL3210-1KE23-8..0
Output current at 400 V 3 AC					
• Rated current $I_{rated}^{1)}$	A	17.0	26.0	32.0	38.0
• Base load current $I_L^{2)}$	A	16.5	25.0	31.0	37.0
• Base load current $I_H^{3)}$	A	12.5	16.5	25.0	31.0
• I_{max}	A	25.0	33.0	50.0	62.0
Rated power					
• Based on I_L	kW (hp)	7.5 (10)	11.0 (15)	15.0 (20)	18.5 (25)
• Based on I_H	kW (hp)	5.5 (7.5)	7.5 (10)	11.0 (15)	15.0 (20)
Rated pulse frequency		kHz	4	4	4
Efficiency η			0.97	0.97	0.97
Power loss at rated current		kW	0.24	0.35	0.43
Cooling air requirement		m^3/s (ft^3/s)	0.009 (0.32)	0.018 (0.64)	0.018 (0.64)
Sound pressure level L_{pA} (1 m)		dB	<63	<66	<66
Rated input current $I_L^{4)}$					
• Based on I_L	A	21.5	33.0	40.6	48.2
• Based on I_H	A	18.2	24.1	36.4	45.2
Length of cable to braking resistor, max.		m (ft)	15 (49)	15 (49)	15 (49)
Line supply connection U1/L1, V1/L2, W1/L3			Plug-in screw terminals	Plug-in screw terminals	Plug-in screw terminals
• Conductor cross-section	mm^2	4 ... 6 (12 ... 10 AWG)	6 ... 16 (10 ... 5 AWG)	6 ... 16 (10 ... 5 AWG)	6 ... 16 (10 ... 5 AWG)
Motor connection U2, V2, W2			Plug-in screw terminals	Plug-in screw terminals	Plug-in screw terminals
• Conductor cross-section	mm^2	4 ... 6 (12 ... 10 AWG)	6 ... 16 (10 ... 5 AWG)	6 ... 16 (10 ... 5 AWG)	6 ... 16 (10 ... 5 AWG)
Connection for braking resistor R1, R2			Plug-in screw terminals	Plug-in screw terminals	Plug-in screw terminals
• Conductor cross-section	mm^2	4 ... 6 (12 ... 10 AWG)	6 ... 16 (10 ... 5 AWG)	6 ... 16 (10 ... 5 AWG)	6 ... 16 (10 ... 5 AWG)
PE connection			On housing with M4 screw	On housing with M4 screw	On housing with M4 screw
Motor cable length, max.⁵⁾					
• Shielded	m (ft)	50 (164)	50 (164)	50 (164)	50 (164)
• Unshielded	m (ft)	100 (328)	100 (328)	100 (328)	100 (328)
Dimensions					
• Width	mm (in)	100 (3.94)	140 (5.51)	140 (5.51)	140 (5.51)
• Height	mm (in)	196 (7.72)	295 (11.61)	295 (11.61)	295 (11.61)
• Depth					
- Without operator panel	mm (in)	203 (7.99)	203 (7.99)	203 (7.99)	203 (7.99)
- With operator panel	mm (in)	224 (8.82)	224 (8.82)	224 (8.82)	224 (8.82)
Frame size			FSB	FSC	FSC
Weight, approx.		kg (lb)	2.3 (5)	4.5 (10)	4.5 (10)

¹⁾ The rated output current I_{rated} can be used up to 100 %; however, without overload.

²⁾ The base load current I_L is based on the duty cycle for low overload (LO).

³⁾ The base load current I_H is based on the duty cycle for high overload (HO).

⁴⁾ The rated input currents are valid for an input voltage of 400 V 3 AC and a line impedance corresponding to $u_K = 1\%$ (without line reactor). The rated input current based on I_L is stamped on the inverter rating plate. In the particular application, the input current depends on the motor load and line impedance. The input current is reduced when using a line reactor.

⁵⁾ The maximum motor cable lengths are valid for an input voltage of 400 V 3 AC and operation with a 4 kHz pulse frequency. To maintain limit values according to EN 61800-3 Category C2, a maximum motor cable length of 25 m (82 ft) (shielded) is permissible.

SINAMICS G120C compact inverters

0.55 kW to 18.5 kW (0.75 hp to 25 hp)

SINAMICS G120C compact inverters

Characteristic curves

Derating data

Pulse frequency

Rated power based on low overload (LO)		Rated output current A for a pulse frequency of						
kW	hp	4 kHz	6 kHz	8 kHz	10 kHz	12 kHz	14 kHz	16 kHz
0.55 ¹⁾	0.75	1.7	1.4	1.2	1.0	0.9	0.8	0.7
0.75 ¹⁾	1.0	2.2	1.9	1.5	1.3	1.1	1.0	0.9
1.1 ¹⁾	1.5	3.1	2.6	2.2	1.9	1.6	1.4	1.2
1.5 ¹⁾	2.0	4.1	3.5	2.9	2.5	2.1	1.8	1.6
2.2 ¹⁾	3.0	5.6	4.8	3.9	3.4	2.8	2.5	2.2
3.0 ¹⁾	4.0	7.3	6.2	5.1	4.4	3.7	3.3	2.9
4.0 ¹⁾	5.0	8.8	7.5	6.2	5.3	4.4	4.0	3.5
5.5	7.5	12.5	10.6	8.8	7.5	6.3	5.6	5.0
7.5	10	16.5	14.0	11.6	9.9	8.3	7.4	6.6
11.0	15	25.0	21.3	17.5	15.0	12.5	11.3	10.0
15.0	20	31.0	26.4	21.7	18.6	15.5	14.0	12.4
18.5	25	37.0	31.5	25.9	22.2	18.5	16.7	14.8

Ambient temperature

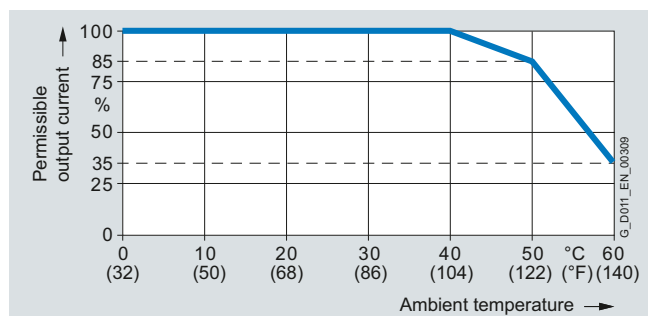

High overload (HO) and low overload (LO)

Line voltage

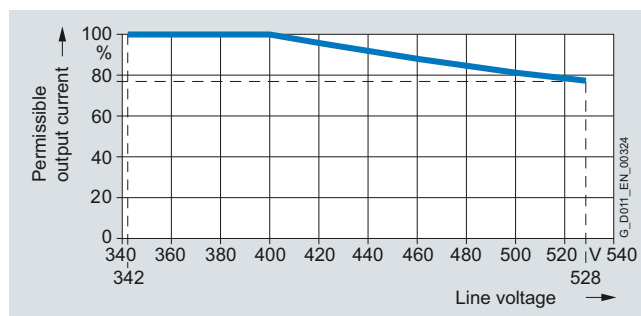

Permissible output current as a function of line voltage

Installation altitude

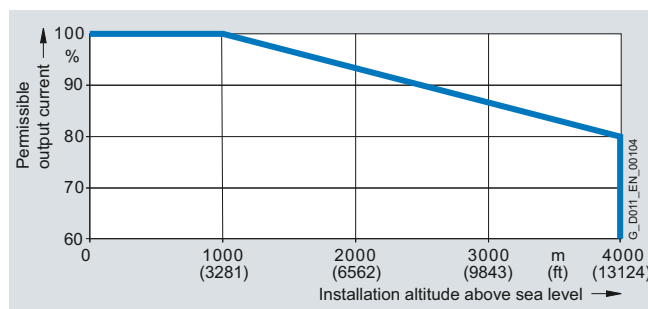

Permissible output current as a function of installation altitude

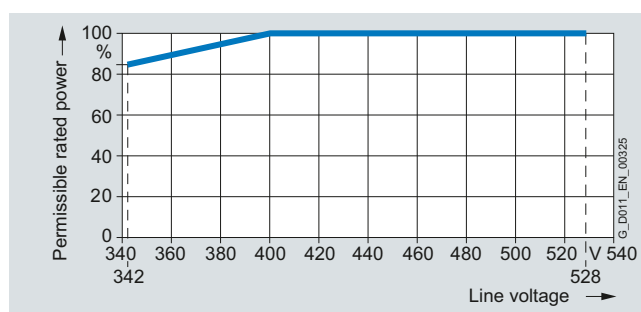

Permissible rated power as a function of line voltage

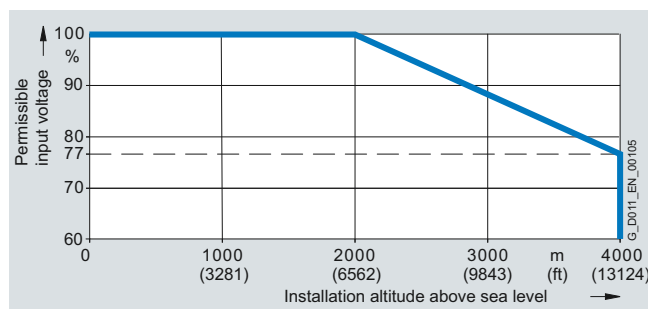

Permissible input voltage as a function of installation altitude

¹⁾ The permissible motor cable length depends on the cable type and the pulse frequency.

SINAMICS G120C compact inverters

0.55 kW to 18.5 kW (0.75 hp to 25 hp)

SINAMICS G120C compact inverters

Dimensional drawings

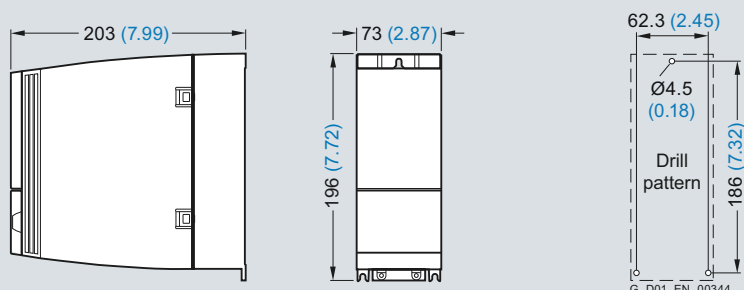

SINAMICS G120C, frame size FSA

Mounted with 3 M4 studs, 3 M4 nuts, 3 M4 washers.

Ventilation clearance required at the top: 80 mm (3.15 inches).

Ventilation clearance required at the bottom: 100 mm (3.94 inches).

Ventilation clearance required at the side: 0 mm (0 inches).

When the IOP is inserted, the mounting depth increases by 21 mm (0.83 inches).

When the BOP-2 is inserted, the mounting depth increases by 11 mm (0.43 inches).

All dimensions in mm (values in brackets are in inches).

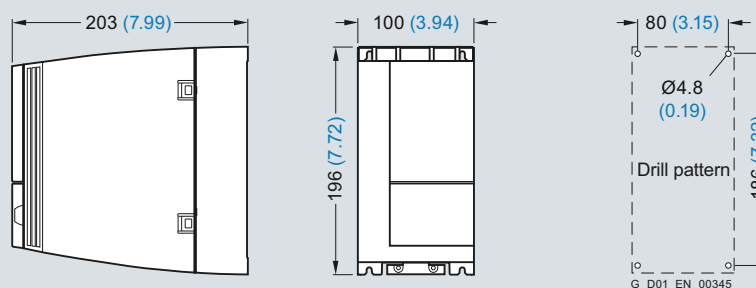

SINAMICS G120C, frame size FSB

Mounted with 4 M4 studs, 4 M4 nuts, 4 M4 washers.

Ventilation clearance required at the top: 80 mm (3.15 inches).

Ventilation clearance required at the bottom: 100 mm (3.94 inches).

Ventilation clearance required at the side: 0 mm (0 inches).

When the IOP is inserted, the mounting depth increases by 21 mm (0.83 inches).

When the BOP-2 is inserted, the mounting depth increases by 11 mm (0.43 inches).

All dimensions in mm (values in brackets are in inches).

SINAMICS G120C compact inverters

0.55 kW to 18.5 kW (0.75 hp to 25 hp)

SINAMICS G120C compact inverters

Dimensional drawings

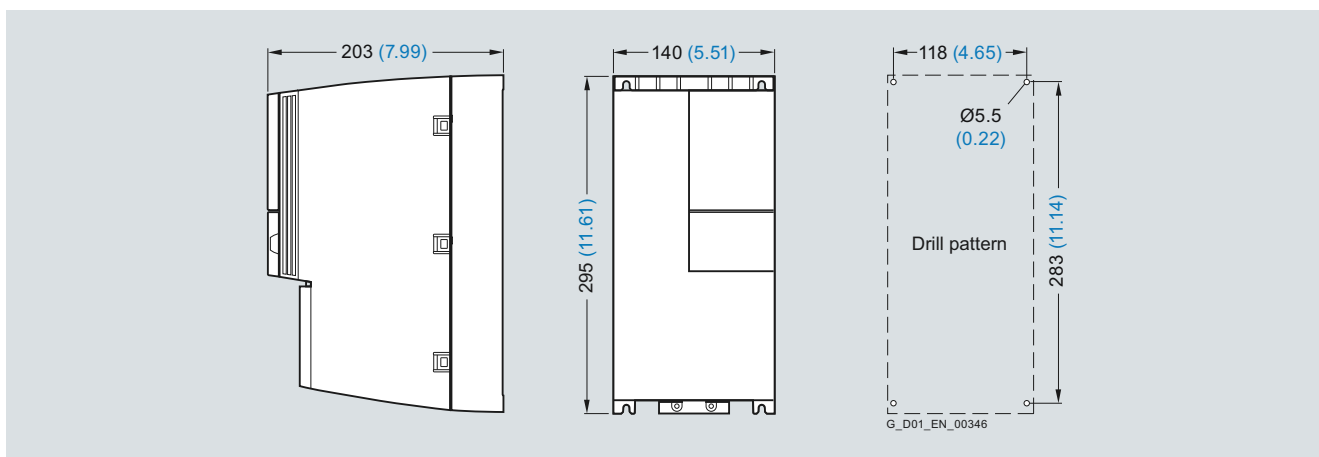

SINAMICS G120C, frame size FSC

Mounted with 4 M5 studs, 4 M5 nuts, 4 M5 washers.

Ventilation clearance required at the top: 80 mm (3.15 inches).

Ventilation clearance required at the bottom: 100 mm (3.94 inches).

Ventilation clearance required at the side: 0 mm (0 inches).

When the IOP is inserted, the mounting depth increases by 21 mm (0.83 inches).

When the BOP-2 is inserted, the mounting depth increases by 11 mm (0.43 inches).

All dimensions in mm (values in brackets are in inches).

More information

Detailed information on SINAMICS G120C, the latest technical documentation (catalogs, dimension drawings, certificates, manuals and operating instructions), are available on the Internet at:

www.siemens.com/sinamics-g120c

You can find information offline about SINAMICS G120C on the DVD-ROM CA 01 in the DT Configurator.

SINAMICS G120C compact inverters

0.55 kW to 18.5 kW (0.75 hp to 25 hp)

Line-side components Line reactors

Overview



Line reactor for SINAMICS G120C, frame size FSB

Line reactors are used to smooth voltage peaks or to bridge commutating dips. Line reactors also reduce the effects of harmonics on the inverter and the line supply.

If the ratio of the rated inverter power to the line supply short-circuit power is less than 1 %, then it is recommended to use a line reactor to reduce the current peaks.

Selection and ordering data

Rated power		Suitable for SINAMICS G120C		Line reactor
kW	hp	Type 6SL3210-...	Frame size	Order No.
Line voltage 380 ... 480 V 3 AC				
0.55	0.75	1KE11-8..0	FSA	6SL3203-0CE13-2AA0
0.75	1	1KE12-3..0		
1.1	1.5	1KE13-2..0		
1.5	2	1KE14-3..0	FSA	6SL3203-0CE21-0AA0
2.2	3	1KE15-8..0		
3	4	1KE17-5..0		
4	5	1KE18-8..0		6SL3203-0CE21-8AA0
5.5	7.5	1KE21-3..0	FSB	
7.5	10	1KE21-7..0		
11	15	1KE22-6..0	FSC	6SL3203-0CE23-8AA0
15	20	1KE23-2..0		
18.5	25	1KE23-8..0		

Technical specifications

Line voltage 380 ... 480 V 3 AC		Line reactor			
		6SL3203-0CE13-2AA0	6SL3203-0CE21-0AA0	6SL3203-0CE21-8AA0	6SL3203-0CE23-8AA0
Rated current	A	4	11.3	22.3	47
Power loss at 50/60 Hz	W	23/26	36/40	53/59	88/97
Line supply/load connection 1L1, 1L2, 1L3 2L1, 2L2, 2L3		Screw-type terminals	Screw-type terminals	Screw-type terminals	Screw-type terminals
• Conductor cross-section	mm ²	4	4	10	16
PE connection		M4 × 8; U washer; spring lock washer	M4 × 8; U washer; spring lock washer	M5 × 10; U washer; spring lock washer	M5 × 10; U washer; spring lock washer
Degree of protection		Control cabinet built-in unit IP20	Control cabinet built-in unit IP20	Control cabinet built-in unit IP20	Control cabinet built-in unit IP20
Dimensions					
• Width	mm (in)	125 (4.92)	125 (4.92)	125 (4.92)	190 (7.48)
• Height	mm (in)	120 (4.72)	140 (5.51)	145 (5.71)	220 (8.66)
• Depth	mm (in)	71 (2.80)	71 (2.80)	91 (3.58)	91 (3.58)
Weight, approx.	kg (lb)	1.1 (2.4)	2.1 (4.6)	2.95 (6.5)	7.8 (17.2)
Suitable for SINAMICS G120C	Type	6SL3210-1KE11-8..0 6SL3210-1KE12-3..0 6SL3210-1KE13-2..0	6SL3210-1KE14-3..0 6SL3210-1KE15-8..0 6SL3210-1KE17-5..0 6SL3210-1KE18-8..0	6SL3210-1KE21-3..0 6SL3210-1KE21-7..0	6SL3210-1KE22-6..0 6SL3210-1KE23-2..0 6SL3210-1KE23-8..0
• Frame size		FSA	FSA	FSB	FSC

SINAMICS G120C compact inverters

0.55 kW to 18.5 kW (0.75 hp to 25 hp)

Line-side components
Recommended line-side power components

Selection and ordering data

The following table lists recommendations for additional line-side components, such as fuses and circuit breakers.

Note for use in compliance with IEC standards:

3NA3 fuses are recommended for European countries. The values in the table take into account the overload capability of the inverter.

Note for use in compliance with UL regulations:

Fuses for use in North America must be UL-certified, such as the Class NON fuse series from Bussmann or approved circuit breakers from the SIRIUS 3RV and SENTRON 3VL series according to UL 489 (category control number CCN: DiV Q). The specified circuit breakers are UL-certified.

An overvoltage protection device is required for installation in conformance with UL corresponding to the UL certification of SINAMICS G120C. The overvoltage protection device must be marked with the Listed test symbol and category code VZCA. The detailed UL installation guidelines are included in the equipment manual.

[Additional information about the listed fuses and circuit breakers can be found in Catalogs LV 1 AO, LV 10.1 and IC 10.](#)

Rated power		Suitable for SINAMICS G120C Type 6SL3210-...	Corresponding to the IEC standard			Corresponding to the UL/cUL standard		
kW	hp		Standard fuse		Circuit breaker	Standard fuse		Circuit breaker
			Current in A	Order No.	Order No.	Current in A	Class	Order No.
Line voltage 380 ... 480 V 3 AC								
0.55	0.75	1KE11-8A.0	6	3NA3801	3RV1021-1DA10	10	J	3RV1021-1DA10
0.75	1	1KE12-3A.0	6	3NA3801	3RV1021-1EA10	10	J	3RV1021-1EA10
1.1	1.5	1KE13-2A.0	6	3NA3801	3RV1021-1FA10	10	J	3RV1021-1FA10
1.5	2	1KE14-3A.0	10	3NA3803	3RV1021-1HA10	10	J	3RV1021-1HA10
2.2	3	1KE15-8A.0	10	3NA3803	3RV1021-1JA10	10	J	3RV1021-1JA10
3.0	4	1KE17-5A.0	16	3NA3805	3RV1021-1KA10	15	J	3RV1021-1KA10
4.0	5	1KE18-8A.0	16	3NA3805	3RV1021-4AA10	15	J	3RV1021-4AA10
5.5	7.5	1KE21-3A.0	20	3NA3807	3RV1021-4BA10	20	J	3RV1021-4BA10
7.5	10	1KE21-7A.0	25	3NA3810	3RV1021-4DA10	25	J	3RV1021-4DA10
11	15	1KE22-6A.0	40	3NA3817	3RV1031-4FA10	40	J	3RV1031-4FA10
15	20	1KE23-2A.0	50	3NA3820	3RV1031-4GA10	50	J	3RV1031-4GA10
18.5	25	1KE23-8A.0	63	3NA3822	3RV1031-4HA10	60	J	3RV1031-4HA10

¹⁾ Rated power based on the rated output current I_{rated} .
The rated output current I_{rated} is based on the duty cycle for low overload (LO).

SINAMICS G120C compact inverters

0.55 kW to 18.5 kW (0.75 hp to 25 hp)

DC link components Braking resistors

Overview



Braking resistor for SINAMICS G120C, frame size FSB

The excess energy of the DC link is dissipated using the braking resistor. The braking resistors are designed for use with the SINAMICS G120C. SINAMICS G120C has an integrated brake chopper and cannot feed back regenerative energy to the line supply. For regenerative operation, e.g. the braking of a rotating mass with high moment of inertia, a braking resistor must be connected to convert the resulting energy into heat.

The braking resistors are designed for mounting horizontally or vertically onto a heat-resistant sheet steel panel. The resistors should be mounted such as to ensure that the air can flow in and out and heat cannot build up. The heat dissipated by the braking resistor must not diminish the inverter cooling.

Every braking resistor is equipped with a temperature switch. The temperature switch can be evaluated to prevent consequential damage if the braking resistor overheats.

Selection and ordering data

Rated power		Suitable for SINAMICS G120C		Braking resistor
kW	hp	Type 6SL3210-...	Frame size	Order No.
Line voltage 380 ... 480 V 3 AC				
0.55	0.75	1KE11-8..0	FSA	6SL3201-0BE14-3AA0
0.75	1	1KE12-3..0		
1.1	1.5	1KE13-2..0		
1.5	2	1KE14-3..0		
2.2	3	1KE15-8..0	FSA	6SL3201-0BE21-0AA0
3	4	1KE17-5..0		
4	5	1KE18-8..0		
5.5	7.5	1KE21-3..0	FSB	6SL3201-0BE21-8AA0
7.5	10	1KE21-7..0		
11	15	1KE22-6..0	FSC	6SL3201-0BE23-8AA0
15	20	1KE23-2..0		
18.5	25	1KE23-8..0		

Technical specifications

Line voltage 380 ... 480 V 3 AC		Braking resistor			
		6SL3201-0BE14-3AA0	6SL3201-0BE21-0AA0	6SL3201-0BE21-8AA0	6SL3201-0BE23-8AA0
Resistance	Ω	370	140	75	30
Rated power P_{DB}	kW	0.075	0.2	0.375	0.925
Peak power P_{max} (on-load factor 5 %)	kW	1.5	4	7.5	18.5
Power connection		Terminal block	Terminal block	Terminal block	Terminal block
• Conductor cross-section	mm ²	2.5	2.5	2.5	6
Thermostatic switch		NC contact	NC contact	NC contact	NC contact
• Contact load, max.		250 V AC/2.5 A	250 V AC/2.5 A	250 V AC/2.5 A	250 V AC/2.5 A
• Conductor cross-section	mm ²	2.5	2.5	2.5	2.5
PE connection					
• Via terminal block		Yes	Yes	Yes	Yes
• PE connection on housing		M4 screw	M4 screw	M4 screw	M4 screw
Degree of protection		IP20	IP20	IP20	IP20
Dimensions					
• Width	mm (in)	105 (4.13)	105 (4.13)	175 (6.89)	250 (9.84)
• Height	mm (in)	295 (11.61)	345 (13.58)	345 (13.58)	490 (19.29)
• Depth	mm (in)	100 (3.94)	100 (3.94)	100 (3.94)	140 (5.51)
Weight, approx.	kg (lb)	1.48 (3.26)	1.8 (3.97)	2.73 (6.02)	6.2 (13.7)
Suitable for SINAMICS G120C	Type	6SL3210-1KE11-8..0 6SL3210-1KE12-3..0 6SL3210-1KE13-2..0 6SL3210-1KE14-3..0	6SL3210-1KE15-8..0 6SL3210-1KE17-5..0 6SL3210-1KE18-8..0	6SL3210-1KE21-3..0 6SL3210-1KE21-7..0	6SL3210-1KE22-6..0 6SL3210-1KE23-2..0 6SL3210-1KE23-8..0
• Frame size		FSA	FSA	FSB	FSC

SINAMICS G120C compact inverters

0.55 kW to 18.5 kW (0.75 hp to 25 hp)

Supplementary system components

Operator panels

Overview

Operator panel	Intelligent Operator Panel IOP and IOP Handheld	Basic Operator Panel BOP-2
		
Description	Thanks to the large plain text display, menu-based operation and the application wizards, commissioning of the standard drives is easy. Integrated application wizards guide the user interactively through the commissioning process for important applications such as pumps, fans, compressors and conveyor systems.	Commissioning of standard drives is easy with the menu-prompted dialog on a 2-line display. Simultaneous display of the parameter and parameter value, as well as parameter filtering, means that basic commissioning of a drive can be performed easily and, in most cases, without a printed parameter list.
Possible applications	<ul style="list-style-type: none"> • Directly mounted on SINAMICS G120C • Can be mounted in the control cabinet door using a door mounting kit (achievable degree of protection is IP54/UL Type 12) • Available as handheld version • 5 languages available 	<ul style="list-style-type: none"> • Directly mounted on SINAMICS G120C • Can be mounted in the control cabinet door using a door mounting kit (achievable degree of protection is IP55/UL Type 12)
Quick commissioning without expert knowledge	<ul style="list-style-type: none"> • Standard commissioning using the clone function • User-defined parameter list with a reduced number of self-selected parameters • Simple commissioning of standard applications using application-specific wizards; it is not necessary to know the parameter structure • Simple local commissioning using the handheld version • Commissioning largely without documentation 	<ul style="list-style-type: none"> • Standard commissioning using the clone function
High degree of operator friendliness and intuitive operation	<ul style="list-style-type: none"> • Direct manual operation of the drive – you can simply toggle between the automatic and manual modes • Intuitive navigation using a rotary knob – just like in everyday applications • Graphic display to show status values such as pressure or flow in bar-type diagrams • Status display with freely selectable units to specify physical values 	<ul style="list-style-type: none"> • Direct manual operation of the drive – you can simply toggle between the automatic and manual modes – • 2-line display for showing up to 2 process values with text • Status display of predefined units
Minimization of maintenance times	<ul style="list-style-type: none"> • Diagnostics using plain text display, can be used locally on-site without documentation • Simple update of languages, wizards and firmware via USB 	<ul style="list-style-type: none"> • Diagnostics with menu prompting with 7-segment display

SINAMICS G120C compact inverters

0.55 kW to 18.5 kW (0.75 hp to 25 hp)

Supplementary system components Intelligent Operator Panel IOP

Overview

Intelligent Operator Panel IOP



Intelligent Operator Panel IOP

The Intelligent Operator Panel IOP is a very user-friendly and powerful operator panel for the SINAMICS G120, SINAMICS G120C, SINAMICS G120D, SINAMICS G120P standard drives and SIMATIC ET 200 frequency converters.

The IOP supports both entry-level personnel and drive experts. Thanks to the large plain text display, the menu-based operation and the application wizards, it is easy to commission standard drives. A drive can be essentially commissioned without having to use a printed parameter list – as the parameters are displayed in plain text, and explanatory help texts and the parameter filtering function are provided.

Application wizards interactively guide you when commissioning important applications such as conveyor technology, pumps, fans and compressors. There are quick commissioning wizards for general commissioning.

Up to 2 process values can be displayed graphically or numerically on the status screen/status display. Process values can also be displayed in technological units.

The IOP supports standard commissioning of identical drives. For this purpose, a parameter list can be copied from an inverter into the IOP and downloaded into other drive units of the same type as required.

The IOP includes the following language packages: English, French, German, Italian and Spanish.

The IOP can be installed in control cabinet doors using the optionally available door mounting kit.

Updating the IOP

The IOP can be updated and expanded using the integrated USB interface.

Data to support future drive systems can be transferred from the PC to the IOP via drag & drop. Further, the USB interface allows user languages and wizards that will become available in the future to be subsequently downloaded and the firmware to be updated for the IOP.

The IOP is supplied with power via the USB interface during an update.

IOP Handheld



IOP Handheld

A handheld version of the IOP can be ordered for mobile use. In addition to the IOP, this includes a housing with rechargeable batteries, charging unit and RS232 connecting cable. The charging unit is supplied with connector adapters for Europe, the US and UK. When the batteries are fully charged, the operating time is up to 8 hours.

To connect the IOP Handheld to SINAMICS G110D and SINAMICS G120D, the RS232 connecting cable with optical interface is required in addition.

Selection and ordering data

Description	Order No.
Intelligent Operator Panel IOP	6SL3255-0AA00-4JA0
IOP Handheld For use with SINAMICS G120, SINAMICS G120C, SINAMICS G110D, SINAMICS G120D, SIMATIC ET 200S FC or SIMATIC ET 200pro FC Included in the scope of delivery:	6SL3255-0AA00-4HA0
<ul style="list-style-type: none"> • IOP • Handheld housing • Rechargeable batteries (4 × AA) • Charging unit (international) • RS232 connecting cable (3 m/9.84 ft long, can only be used for SINAMICS G120 and SIMATIC ET 200S FC) • USB cable (1 m/3.28 ft long) 	
Accessories	
Door mounting kit For mounting an operator panel in control cabinet doors with sheet steel thicknesses of 1 ... 3 mm (0.04 ... 0.12 in) IP54 degree of protection for IOP IP55 degree of protection for BOP-2 Included in the scope of delivery:	6SL3256-0AP00-0JA0
<ul style="list-style-type: none"> • Seal • Mounting material • Connecting cable (5 m/16.4 ft long) 	

SINAMICS G120C compact inverters

0.55 kW to 18.5 kW (0.75 hp to 25 hp)

Supplementary system components
Intelligent Operator Panel IOP

Benefits

- Simple commissioning of standard applications using wizards, it is not necessary to know the parameter structure
- Diagnostics using plain text display; can be used locally on-site without documentation
- Direct manual operation of the drive; you can toggle between the automatic and manual modes
- Status display with freely selectable units; display of real physical values
- Intuitive navigation using a wheel – just like in everyday applications
- Graphic display with bar charts e.g. for status values such as pressure or flowrate
- Quickly and simply mounted in the door – mechanically and electrically
- Simple local commissioning on-site using the handheld version
- Commissioning without documentation using the integrated help function
- Standard commissioning using the clone function (parameter set data is saved for fast replacement)
- User-defined parameter list with a reduced number of self-selected parameters (to generate your own commissioning screens)
- 5 integrated languages
- Simple update of languages, wizards and firmware updates via USB

Integration

Using the optionally available door mounting kit, an operator panel can be simply mounted in a control cabinet door with just a few manual operations. For door mounting with an IOP, degree of protection IP54/UL Type 12 is achieved, and with BOP-2, degree of protection IP55.

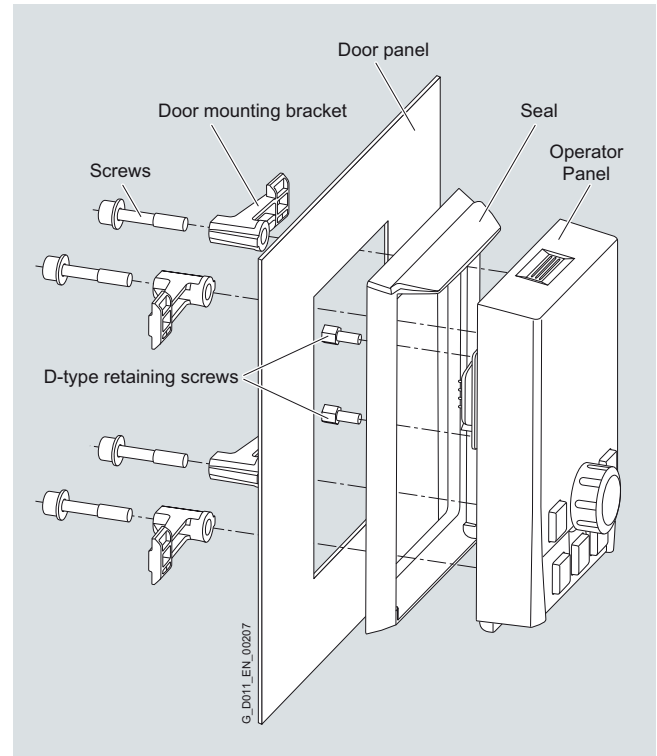

Door mounting kit with IOP

SINAMICS G120C compact inverters

0.55 kW to 18.5 kW (0.75 hp to 25 hp)

Supplementary system components Basic Operator Panel BOP-2

Overview



Basic Operator Panel BOP-2

The Basic Operator Panel BOP-2 can be used to commission drives, monitor drives in operation and input individual parameter settings.

Commissioning of standard drives is easy with the menu-prompted dialog on a 2-line display. Simultaneous display of the parameter and parameter value, as well as parameter filtering, means that basic commissioning of a drive can be performed easily and, in most cases, without a printed parameter list.

The drives are easily controlled manually using directly assigned navigation buttons. The BOP-2 has a dedicated switchover button to switch from automatic to manual mode.

Diagnostics can easily be performed on the connected inverter by following the menus.

Up to 2 process values can be numerically visualized simultaneously.

BOP-2 supports standard commissioning of identical drives. For this purpose, a parameter list can be copied from an inverter into the BOP-2 and when required, downloaded into other drive units of the same type.

Benefits

- Shorten commissioning times – Easy commissioning of standard drives using basic commissioning wizards (setup)
- Minimize standstill times – Fast detection and rectification of errors (Diagnostics)
- Greater transparency in the process – The status display of the BOP makes process variable monitoring easy (Monitoring)
- Direct mounting on the inverter ([also see IOP](#))
- User-friendly user interface:
 - Easy navigation using clear menu structure and clearly assigned control keys
 - Two-line display

Selection and ordering data

Description	Order No.
Basic Operator Panel BOP-2	6SL3255-0AA00-4CA1
Accessories	
Door mounting kit	6SL3256-0AP00-0JA0
For mounting an operator panel in control cabinet doors with sheet steel thicknesses of 1 ... 3 mm (0.04 ... 0.12 in) IP54 degree of protection for IOP IP55 degree of protection for BOP-2	
Included in the scope of delivery:	
<ul style="list-style-type: none"> • Seal • Mounting material • Connecting cable (5 m/16.4 ft long) 	

SINAMICS G120C compact inverters

0.55 kW to 18.5 kW (0.75 hp to 25 hp)

Supplementary system components Memory cards

Supplementary system components PC inverter connection kit 2

Overview



SINAMICS micro memory card (MMC)/SIMATIC memory card (SD card)

The parameter settings for an inverter can be stored on the SINAMICS micro memory card (MMC) or SIMATIC memory card (SD card). When service is required, e.g. after the inverter has been replaced and the data have been downloaded from the memory card the drive system is immediately ready for use again.

- Parameter settings can be written from the memory card to the inverter or saved from the inverter to the memory card.
- Up to 100 parameter sets can be stored.
- The memory card supports standard commissioning without the use of an operator panel such as the BOP-2 or the STARTER commissioning tool.

Note:

The memory card is not required for operation and does not have to remain inserted.

Selection and ordering data

Description	Order No.
SINAMICS micro memory card (MMC)	6SL3254-0AM00-0AA0
SIMATIC memory card (SD card) (for SINAMICS G120C and the SINAMICS G120 CU2 . 0 . -2 Control Units)	6ES7954-8LB01-0AA0

Overview

For controlling and commissioning an inverter directly from a PC, if the STARTER commissioning tool has been installed on the PC. With this, the inverter can be

- parameterized (commissioned, optimized),
- monitored (diagnostics)
- controlled (master control via the STARTER commissioning tool for test purposes).

A USB cable (3 m/9.84 ft) and the STARTER commissioning tool on DVD-ROM are included in the scope of delivery.

Selection and ordering data

Description	Order No.
PC inverter connection kit 2 for SINAMICS G120C and SINAMICS G120 Control Units CU2 . 0 . -2 Including USB cable (3 m/9.84 ft) and STARTER commissioning tool on DVD-ROM ¹⁾	6SL3255-0AA00-2CA0

¹⁾ The STARTER commissioning tool is also available on the Internet at <http://support.automation.siemens.com/WW/view/en/10804985/133100>

SINAMICS G120C compact inverters

0.55 kW to 18.5 kW (0.75 hp to 25 hp)

Spare parts

Overview

The following spare parts are available for SINAMICS G120C for service and maintenance work.

SINAMICS G120C shield plates

A set of shield plates can be ordered for the motor and signal cables corresponding to the frame size of the SINAMICS G120C compact inverter.

SINAMICS G120C Spare Parts Kit

This kit comprises 5 sets of I/O terminals, 1 RS485 terminal, 2 Control Unit doors and 1 blanking cover.

SINAMICS G120, SINAMICS G120C connectors

A set of connectors for the line feeder cable, braking resistor and motor cable can be ordered corresponding to the frame size of the SINAMICS G120C compact inverter.

SINAMICS G120C roof-mounted fan

A roof-mounted fan (at the top of the device) comprising a pre-assembled unit with holder and fan can be ordered corresponding to the frame size of the SINAMICS G120C compact inverter.



SINAMICS G120C, frame size FSB, with integrated roof-mounted fan

SINAMICS G120, SINAMICS G120C fan unit

A replacement fan (at the rear of the device; heat sink) comprising a pre-assembled unit with holder and fan can be ordered corresponding to the frame size of the SINAMICS G120C compact inverter.



SINAMICS G120C, frame size FSB, with fan unit (rear view of rotated inverter)

Selection and ordering data

Description	Order No.
SINAMICS G120C shield plate	
• Frame size FSA	6SL3266-1EA00-0KA0
• Frame size FSB	6SL3266-1EB00-0KA0
• Frame size FSC	6SL3266-1EC00-0KA0
SINAMICS G120C Spare Parts Kit	6SL3200-0SK40-0AA0
SINAMICS G120, SINAMICS G120C connectors	
• Frame size FSA	6SL3200-0ST05-0AA0
• Frame size FSB	6SL3200-0ST06-0AA0
• Frame size FSC	6SL3200-0ST07-0AA0
SINAMICS G120C roof-mounted fan	
• Frame size FSA	6SL3200-0SF40-0AA0
• Frame size FSB	6SL3200-0SF41-0AA0
• Frame size FSC	6SL3200-0SF42-0AA0
SINAMICS G120, SINAMICS G120C fan unit	
• Frame size FSA	6SL3200-0SF12-0AA0
• Frame size FSB	6SL3200-0SF13-0AA0
• Frame size FSC	6SL3200-0SF14-0AA0