

Schneider's local support

Schneider is committed to supporting its customers at every stage of a project. Our 180 sales engineers, the largest dedicated sales force in the UK electrical industry, operate from 4 customer support centres.

Our sales engineers are skilled at assessing individual requirements and combined with the expert support of our product specialists, will develop the most effective and economical answer taking relevant regulations and standards fully into account.

To access the expertise of the Schneider group, please contact your local customer support centre. Each centre includes facilities for demonstrations and training, and presentation rooms fully equipped with audio visual and video, providing excellent meeting facilities.

Regional product showrooms

Midlands	North East
University of Warwick Science Park, Sir William Lyons Road, Coventry, CV4 7EZ. Tel: 01203 847551 Fax: 01203 417517	123 Jack Lane, Hunslet, Leeds, LS10 1BS. Tel: 0113 290 3500 Fax: 0113 290 3710

Local customer support centres

Scotland	North West	South West	Greater London
Unit 11000, Academy Business Park, Gower Street, Glasgow, G51 1PR. Tel: 0141 419 3300 Fax: 0141 419 3323 Email address: scotland@schneider.co.uk	8 Brindley Road, City Park Business Village, Cornbrook, Manchester, M16 9HQ. Tel: 0161 877 0424 Fax: 0161 877 0410 Email address: northern@schneider.co.uk	190 Park Avenue, Aztec West, Almondsbury, Bristol, BS32 4TP. Tel: 01454 628000 Fax: 01454 628010 Email address: southwest@schneider.co.uk	33 Golden Square, London, W1R 3PA. Tel: 0171 440 2400 Fax: 0171 440 2424 Email address: southeast@schneider.co.uk

Schneider - expertise in electrical distribution, industrial control and automation

Schneider is the leading UK and world expert in the development and manufacture of products for the distribution and industrial applications of electricity. In the UK, Schneider operates from 18 industrial and commercial sites, providing employment for 2,500 people, and achieves an annual turnover in excess of £270 million.

With its brands, Merlin Gerin, Modicon, Square D and Telemecanique, Schneider offers a full range of products and services for Panel Builders, OEMs, Contractors, Specifiers and the electrical supply industry for commercial and industrial applications.



Merlin Gerin is one of the leading experts in electrical distribution technology. Its comprehensive array of extra-high, medium and low voltage products and systems is designed to manage and protect electrical installations, ensure safety and supply power reliability and continuity for commercial and industrial buildings.

Telemecanique is a UK market leader and world expert in industrial control and automation. It provides complete solutions, with its range of components, programmable logic controllers, variable speed drives and communications software. In addition, it offers power distribution through prefabricated busbar trunking.

Modicon is a leading manufacturer and worldwide marketer of high technology programmable controllers (PLCs) and motion control systems used in industrial automation. Its international catalogue of products and services include PLCs, numerical controllers, specialised programming and software, fieldbus communication networks and interface terminals.

Square D is a total quality organisation and its business is to put electricity to work productively and effectively, protecting people, buildings and equipment. Its low voltage electrical distribution equipment, systems and services are used world wide in commercial applications.



Internet address: <http://www.schneider.co.uk>

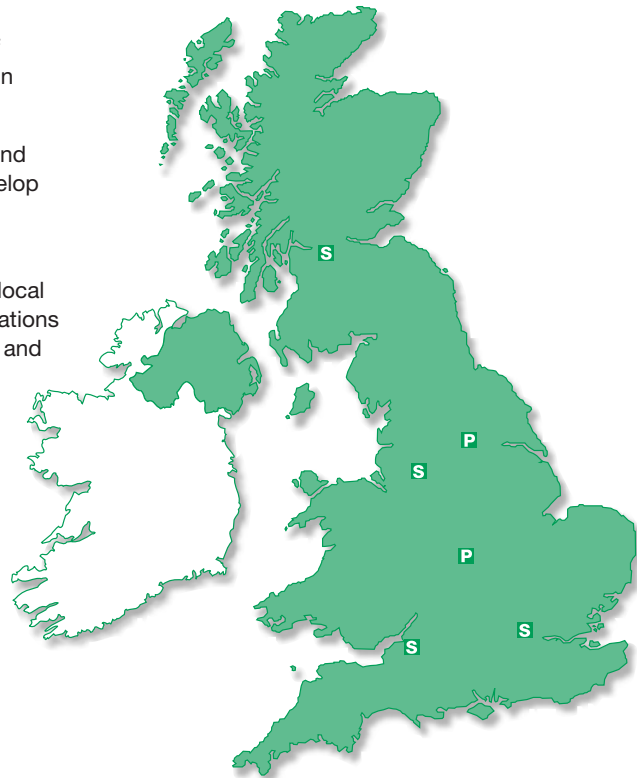

Telemecanique

Altivar 08 drive

March

99



Telemecanique

Drives...

Altivar 08 – drive

Altivar 08

Altivar 08

Telemecanique

Drives...

Easy to install



IP67

Using Telemecanique's expertise in drive solutions, the Altivar 08 has to be capable of easy and inexpensive physical installation whatever the application.

To address this, the new Altivar 08 drives are available in two formats.

Standard heatsink drive – IP20

The product is suited to be mounted inside another enclosure as with other control equipment and will form part of the overall control panel controlling machinery or process.

application
adaptability



IP20



It's simple...

Motor starter drive – IP67

The motor starter solution is a self-contained drive with lower isolation, stop-start, forward/reverse and speed control capability, built into a standard off the shelf product. As the product also has a high ingress protection level it is an ideal solution for the replacement of traditional motor starting solutions where the need for speed control or mechanical soft start is now a requirement.

With both options stocked, the applications available to the designer include:

- mechanical variable drives solutions
- electronic drives solutions
- electro-mechanical solutions.

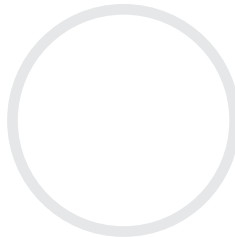

Altivar 08

Designed for your control

The Altivar 08 drive is a compact, functional drive that has been developed to control low power AC induction motors.

Complementing the existing Telemecanique drive range, the Altivar 08 incorporates the latest technology to meet the requirements of applications in the lower power segment.

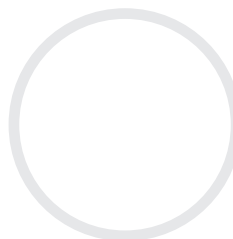

Available in two enclosure formats as standard, each with the same electrical specification and drive performance:

- standard heatsink – IP20
- motor starter drive – IP67.

Three power ratings ... single phase 200 .. 240v / 50..60Hz:

- 0.18kW
- 0.37kW
- 0.75kW.

*economy
of power...*



Contents

Presentation	Page 9
Characteristics	Pages 10 and 11
References	Pages 12 and 13
Dimensions and schemes	Page 14
Mounting	Page 15
Functions	Pages 16 to 19

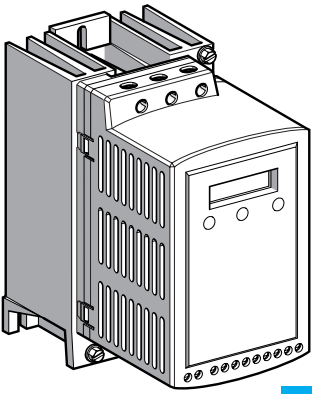

1

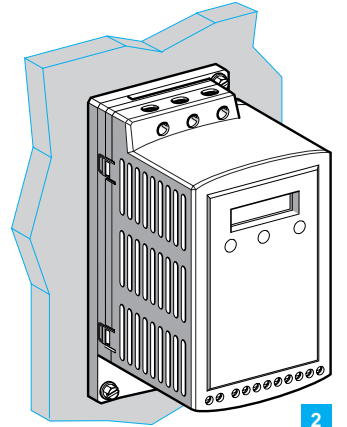

2

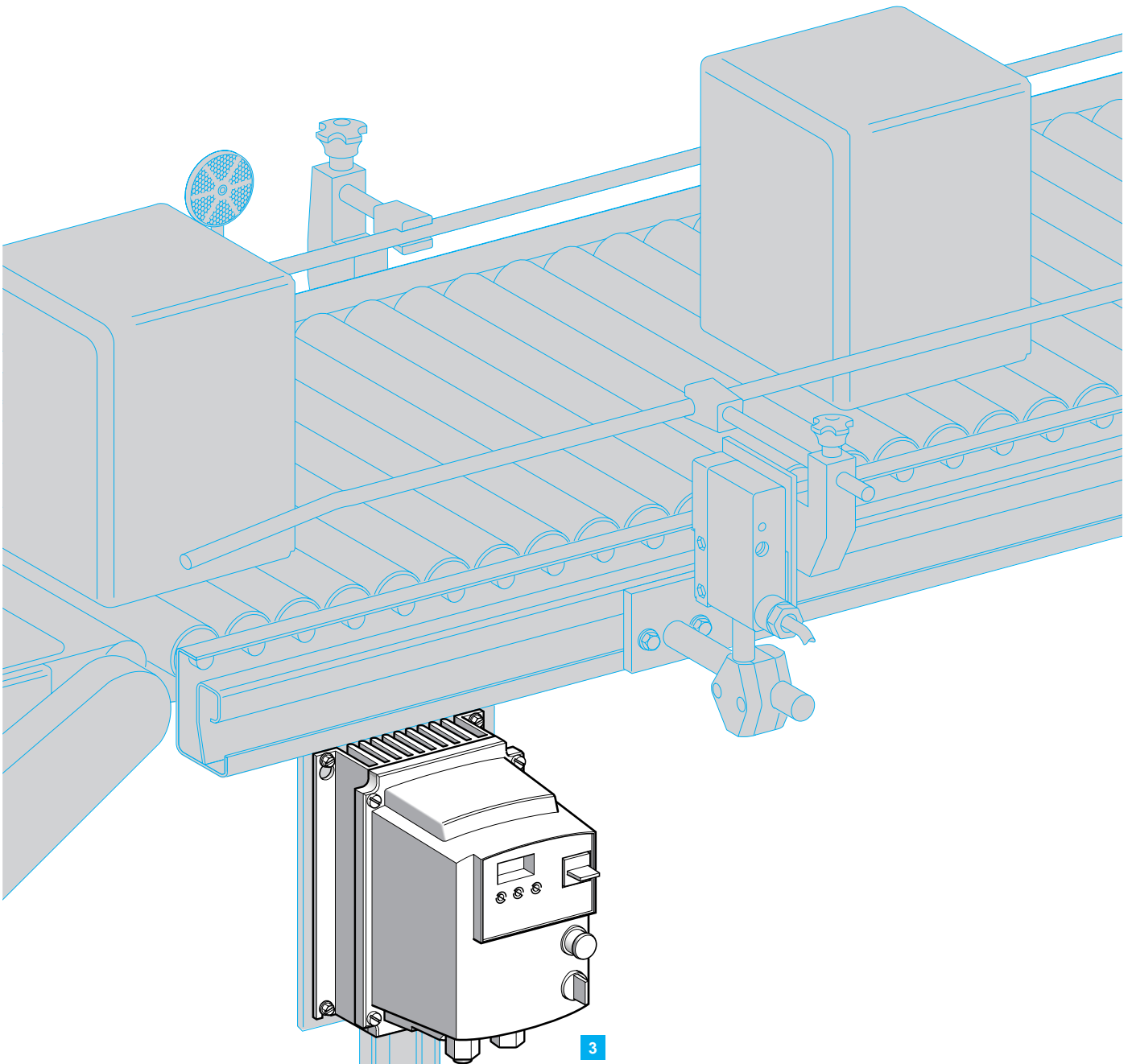

3

Variable speed controllers for asynchronous motors

Characteristics :
pages 10 and 11
References :
pages 12 and 13
Dimensions, schemes :
pages 14 and 15
Functions :
pages 16 to 19

Altivar 08

Presentation

Applications

As a frequency inverter for 3-phase asynchronous squirrel cage motors and single-phase 200 to 240 V asynchronous motors, the Altivar 08 incorporates the latest technological developments. Its functions meet the requirements of the most up-to-date applications, notably :

- horizontal materials handling (conveyors, etc)
 - packing/packaging (gluing machines, labelling machines, etc)
 - special machines (mixers, display units, etc)
-

Functions

The main functions are :

- starting and speed control
 - inversion of the operating direction
 - deceleration, acceleration, stopping
 - motor and speed controller protection, etc
-

Versions

The Altivar 08 is available in three versions for integration into machines :

- **ATV-08HU●●●● standard speed controller with heatsink** (label **1**)
For normal ambiance, within enclosure.
 - **ATV-08PU●●●● speed controller with base plate** (label **2**)
Enables the speed controller to be mounted on the machine frame where the mass of the frame allows for heat adsorption. In this case, no special cut-outs are required other than the fixing holes for the speed controller.
 - **ATV-08EU●●●● ready-assembled speed controller** (label **3**)
This IP 65 enclosure comprises a speed controller with a built-in EMC filter, a power switch, direction inverter and a potentiometer used to adjust the speed.
This enclosure, fully wired and ready to use, can be installed close to the motor.
-

Electromagnetic compatibility (EMC)

The Altivar 08 has built-in EMC filters. The incorporation of filters in the speed controllers simplifies installation and reduces the cost of conformity for CE marking.
They are sized to conform to the following standards : EN 61800-3/IEC 1800-3, public and industrial supplies.

ATV-08HU●●●● and ATV-08PU●●●● speed controllers are also available without EMC filters if conformity to EMC standards is not required.

Variable speed controllers for asynchronous motors

Presentation :
pages 8 and 9
References :
pages 12 and 13
Dimensions, schemes :
pages 14 and 15
Functions :
pages 16 to 19

Altivar 08

Characteristics

Environment

Conformity to standards		<p>Altivar 08 speed controllers have been developed to conform to the strictest international standards and to the recommendations for electrical industrial control devices (IEC, EN), notably :</p> <ul style="list-style-type: none"> ● EN 50178 ● EMC immunity : <ul style="list-style-type: none"> - IEC 61000-4-2/EN 61000-4-2 level 3 - IEC 61000-4-3/EN 61000-4-3 level 3 - IEC 61000-4-4/EN 61000-4-4 level 4 - IEC 61000-4-5/EN 61000-4-5 level 3 (access to power) - IEC 61800-3/EN 61800-3, environments 1 and 2 ● EMC, conducted and radiated emissions : <ul style="list-style-type: none"> - IEC 1800-3/EN 61800-3, environments : 2 (industrial supply) and 1 (public supply) with restricted distribution - EN 55011, EN 55022 class B (radio interference suppression filters included)
CE marking		The speed controllers have CE marking in respect of the European low voltage (73/23/CEE and 93/68/CEE) and EMC (89/336/CEE) directives.
Product certifications		UL and CSA
Degree of protection		IP 20 : ATV-08PU●●●● and ATV-08HU●●●● speed controllers, all ratings IP 65 : ATV-08EU●●●● speed controllers, all ratings
Vibration resistance		Conforming to IEC 68-2-6 : - 1.5 mm peak from 3 to 13 Hz - 1 gn from 13 to 200 Hz
Shock resistance		15 gn for 11 ms conforming to IEC 68-2-27
Maximum relative humidity		93 % without condensation or dripping water, conforming to IEC 68-2-3
Ambient air temperature in the vicinity of the device		
Storage	°C	- 25...+ 65
Operation	°C	<p>ATV-08PU●●●● and ATV-08EU●●●● speed controllers, all ratings : 0...+ 40</p> <p>ATV-08HU●●●● speed controllers, all ratings :</p> <ul style="list-style-type: none"> ● 0...+ 40 without derating ● Up to + 60 with current derating of 2.2 % per °C above 40 °C
Maximum operating altitude	m	1000 without derating (above this, derate the current by 1 % per additional 100 m)
Operating position		Vertical for ATV-08HU●●●● and ATV-08EU●●●● Vertical for horizontal for ATV08PU●●●●

Drive characteristics

Output frequency range	Hz	0.5...120
Switching frequency	kHz	4
Speed range		1...10
Transient overtorque		150 % of nominal motor torque
Braking torque		50 % of nominal motor torque
Maximum transient current		120 % of speed controller nominal current for 20 s 150 % of speed controller nominal current for 1 s

Variable speed controllers for asynchronous motors

Presentation :
pages 8 and 9
References :
pages 12 and 13
Dimensions, schemes :
pages 14 and 15
Functions :
pages 16 to 19

Altivar 08

Characteristics (cont.)

Electrical characteristics

Power supply	Voltage	V	200 - 10 % to 240 + 10 % single-phase
	Frequency	Hz	50 ± 5 % or 60 ± 5 %
	I _{cc}	A	≤ 1000 (presumed short-circuit current at connection point)
Output voltage			Maximum 3-phase voltage equal to mains supply voltage
Electrical isolation			Electrical isolation between power and control (inputs, outputs, supplies)
Available internal supplies			Protected against short-circuits and overloads : - One + 5 V supply for the setpoint potentiometer (2.2 kΩ), maximum rate 10 mA - One + 5 V supply for control inputs, maximum rate 100 mA
Analogue input AI			1 configurable analogue input : - voltage 0-5 V, impedance 50 kΩ - voltage 0-10 V, impedance 50 kΩ - current 0-20 mA or 4 - 20 mA with the addition of a 500 Ω external resistor
Logic inputs LI			4 assignable logic inputs with an impedance of 5 kΩ + 15 V internal or 24 V external power supply (11 V min., 30 V max.) State 0 if < 5 V, state 1 if ≥ 10 V Sampling time : 30 ms max.
Analogue outputs AO			Open collector PWM type output at 1.2 kHz. Max. current 10 mA Output impedance 1 kΩ Linearity ± 1 %
Logic outputs			1 relay logic output R1 (open contact when fault present and protected against overvoltages) 1 N/O contact Minimum switching capacity : 10 mA for ~ 24 V Maximum switching capacity : ● on resistive load (cos φ = 1) : 5 A for ~ 250 V or ~ 30 V ● on inductive load (cos φ = 0.3 and L/R = 10 ms) : 2 A for ~ 250 V or ~ 30 V
Acceleration and deceleration ramps			Ramp shape : linear Automatic adaptation of the deceleration ramp time if the braking capacity is exceeded
Braking to a standstill			d.c. injection : automatically on stopping if the frequency falls below 0.5 Hz, duration adjustable from 0 to 20 s or continuous, current adjustable from 0.25 I _n to I _n
Main protective and safety devices on the speed controller			<ul style="list-style-type: none"> ● Thermal protection against excessive overheating ● Protection against short-circuits between output phases ● Protection against overcurrents between output phases and ground on power up ● Mains undervoltage and overvoltage protection
Motor protection			Thermal protection integrated in the speed controller by continuous calculation of I ² t Thermal memory cleared when switched off
Insulation resistance to earth		MΩ	> 500 (electrical isolation)

Variable speed controllers for asynchronous motors

Presentation :
pages 8 and 9
References :
pages 12 and 13
Dimensions, schemes :
pages 14 and 15
Functions :
pages 16 to 19

Altivar 08
for asynchronous motors from 0.18 to 0.75 kW
Single-phase supply voltage 200...240 V 50/60 Hz

References



ATV-08HU●●●●

Speed controllers with heatsink (frequency range from 0.5 to 120 Hz)

Motor Power indicated on rating plate	Mains supply Line current for presumed lcc 1 kA	Altivar 08 Permanent output current	Maximum transient current (1)	Power dissipated at nominal load	Reference	Weight
kW	A	A	A	W		kg
0.18	2.7	1.1	1.32	15	ATV-08HU05M2 (2)	1.000
0.37	4.5	2.1	2.52	27	ATV-08HU09M2 (2)	1.000
0.75	8.2	3.6	4.32	39	ATV-08HU18M2 (2)	1.150



ATV-08PU●●●●

Speed controllers on baseplate (frequency range from 0.5 to 120 Hz)

0.18	2.7	1.1	1.32	15	ATV-08PU05M2 (2)	0.880
0.37	4.5	2.1	2.52	27	ATV-08PU09M2 (2)	0.880
0.75	8.2	3.6	4.32	39	ATV-08PU18M2 (2)	0.910



ATV-08EU●●●●

Ready-assembled speed controllers (frequency range from 0.5 to 120 Hz)

0.18	2.7	1.1	1.32	–	ATV-08EU05M2	2.500
0.37	4.5	2.1	2.52	–	ATV-08EU09M2	2.500
0.75	8.2	3.6	4.32	–	ATV-08EU18M2	2.500

(1) For 20 seconds.

(2) Speed controller supplied with built-in RFI filter. For a speed controller without filter, add an X at the end of the reference. Example : for the **ATV-08HU05M2** controller without filter, the reference would be : **ATV-08HU05M2X**. In this case the speed controller does not conform to EMC emissions standards.

Variable speed controllers for asynchronous motors

Presentation :
pages 8 and 9
References :
pages 12 and 13
Dimensions, schemes :
pages 14 and 15
Functions :
pages 16 to 19

Altivar 08
for asynchronous motors from 0.18 to 0.75 kW
Single-phase supply voltage 200...240 V 50/60 Hz

References, associations

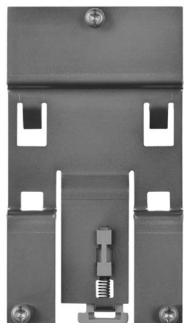

VW3-A08851



VW3-A08831



GB2-DB
+
ATV-08



Accessories for speed controllers with heatsink

Description	Reference	Weight kg
Plate for mounting on  rail (width 35 mm)	VW3-A08851	0.250
Flange to assist EMC mounting	VW3-A08831	0.160

Additional components for customer assembly

Function : to ensure the protection of people and equipment, regardless of the level of overcurrent encountered (overload or short-circuit).

Power ratings for 3-phase, 4-pole 50/60 Hz 230 V motors kW	Circuit-breaker		Maximum short-circuit current kA	Speed controller Reference (1)
	Reference	Rating A		
0.18	GB2-DB10	5	1	ATV-08●U05M2
0.37	GB2-DB10	5	1	ATV-08●U09M2
0.75	GB2-DB16	10	1	ATV-08●U18M2

(1) Replace the bullet point in the reference according to the type of speed controller required (see page opposite).

Variable speed controllers for asynchronous motors

Presentation :
pages 8 and 9
Characteristics :
pages 10 and 11
References :
pages 13 and 14
Functions :
pages 16 to 19

Altivar 08

Dimensions, schemes

Dimensions

ATV-08HU●●●● (with heatsink)
ATV-08HU05M2

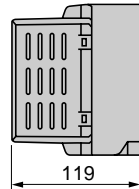

ATV-08HU09M2
and 08HU18M2

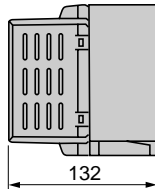

Common front view

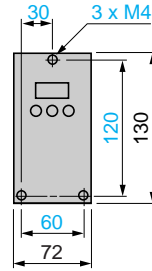

ATV-08PU●●●●
(on baseplate)
all ratings

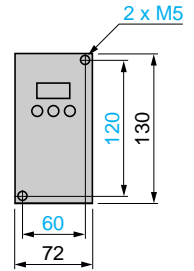
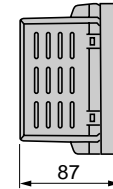

ATV-08EU●●●● (ready-assembled)
all ratings

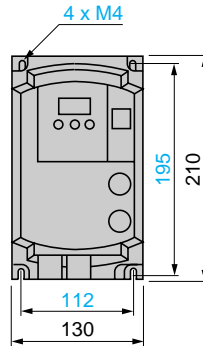
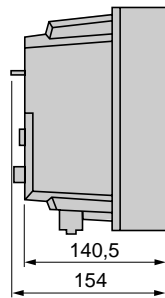

Flange for EMC mounting
VW3-A08831

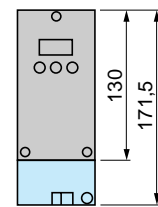

Schemes (basic schemes only: to be adapted to meet local standards and regulations)

ATV-08HU●●●● and ATV-08PU●●●●

200...240 V 50/60 Hz

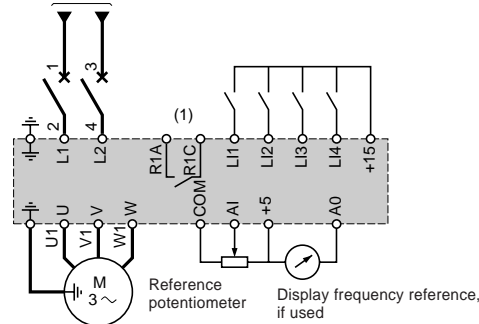

(1) Fault relay contact, signals the state of the controller remotely (open when fault present or power off):

- L11 : forward
- L12 : reverse
- L13/L14 : 4 preset speeds : speed 1 (L13 = 0, L14 = 0), speed 2 (L13 = 1, L14 = 0), speed 3 (L13 = 0, L14 = 1), speed 4 (L13 = 1, L14 = 1).

ATV-08EU●●●●

200...240 V 50/60 Hz

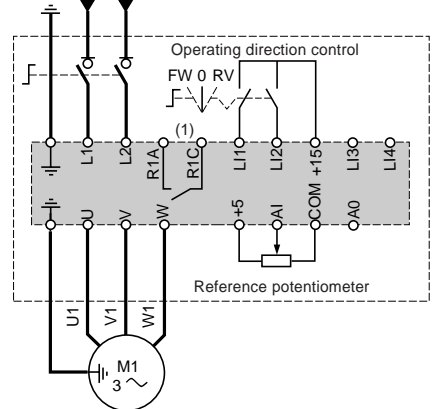

Analogue input
Use 10 V external

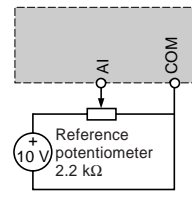

Analogue input
0-20 or 4-20 mA

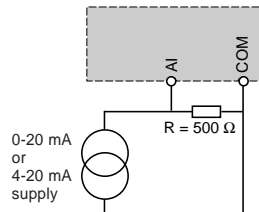

Analogue output
Use 10 V external

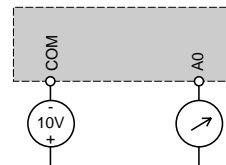

Variable speed controllers for asynchronous motors

Presentation :
pages 8 and 9
Characteristics :
pages 10 and 11
References :
pages 13 and 14
Functions :
pages 16 to 19

Altivar 08

Mounting

Installation precautions

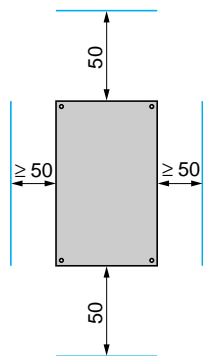

Install the device vertically, at $\pm 10^\circ$, except for the ATV-08PU●●●● which can be installed vertically or horizontally.

- Do not place it close to heating elements.
- Leave sufficient clearance for air circulation necessary for cooling. Cooling is via an air flow from bottom to top.
- Clearance in front of the device : 10 mm minimum.

Precautions when mounting on the machine frame (specific to ATV-08PU●●●● controllers)

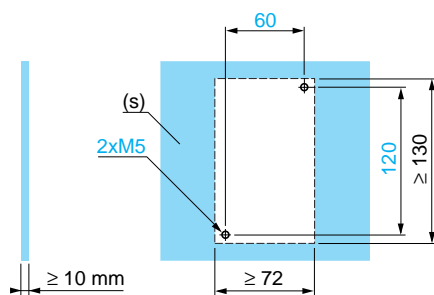

These can be mounted on (or in) a steel or aluminium machine frame, if the following conditions are respected :

- Maximum ambient temperature : 40°C
 - Speed controller contact surface (130 x 72) machined on frame, with a smooth surface of $100\ \mu\text{m}$ max. and unevenness of $3.2\ \mu\text{m}$ max.
 - The variable speed controller must be fixed in the centre of a support (frame) with a minimum thickness of 10 mm and a minimum cooling surface area ($0.12\ \text{m}^2$ for steel or $0.09\ \text{m}^2$ for aluminium), open to the air.
- To ensure heat transfer, thermal contact grease (or equivalent) must be applied to all contact surfaces. Check this mounting when operating conditions are close to the maximum limits (power, cycle and temperature) by monitoring the thermal state (tHd) of the controller.

Mounting for conformity to EMC standards

Principle :

- High frequency potentiality of earthing between the speed controller, the motor and the cable shielding
- Use of shielded cables with 360° connection of the shield to earth at both ends for the motor cable and the control-command cables. This shielding can be provided by metal tubes or ducting provided that continuity is guaranteed.
- The power supply cable (mains) and motor cable should be kept as far apart as possible.

Installation layout for ATV-08HU●●●● :

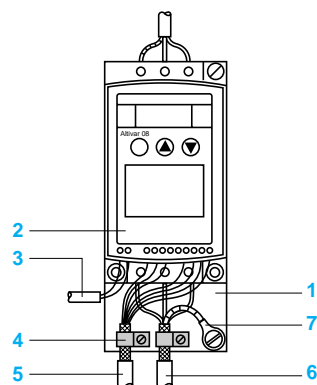

- 1 VW3-A08831 flange (supplied with two metallic clamps) to be mounted on the controller.
To respect radiated emissions, we recommend that this flange (to be ordered separately) is used to earth the cable shielding. However, for level A, earthing the cables to the machine ground wiring using clamps (enclosure backplane or machine frame) is sufficient.
- 2 Altivar 08
- 3 Unshielded cable for the fault relay contact output
- 4 Metal clamps
- 5 Shielded cables for control/command connection
- 6 Shielded cable for motor connection
- 7 Lug for PE conductor

For the ATV-08PU●●●●, attach the clamps directly to the machine ground wiring as close as possible to the speed controller. ATV-08EU●●●● speed controllers already meet EMC requirements.

Variable speed controllers for asynchronous motors

Presentation :
pages 8 and 9
Characteristics :
pages 10 and 11
References :
pages 12 and 13
Dimensions, schemes :
pages 14 and 15

Altivar 08

Functions

Operating speed range

Function : determines the 2 frequency limits which define the speed range permitted by the machine in real operating conditions.

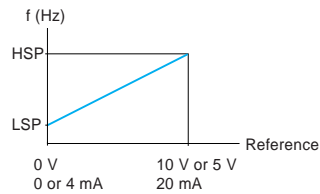

Adjustments :

LSP : low speed, 0 to HSP, factory preset 0.

HSP : high speed, LSP to 120 Hz, factory preset 50 Hz.

Acceleration and deceleration ramp times

Function : determines the acceleration and deceleration times as a function of the application and the machine dynamics.

Adjustments : acceleration (ACC) and deceleration (DEC). Adjustment 0.1 to 100 s, factory preset 3 s.

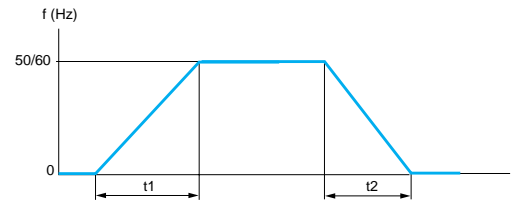

t_1 : ACC

t_2 : DEC

Variable speed controllers for asynchronous motors

Presentation :
pages 8 and 9
Characteristics :
pages 10 and 11
References :
pages 12 and 13
Dimensions, schemes :
pages 14 and 15

Altivar 08

Functions (cont.)

2-wire control

Function : controls the operating direction via stay-put contact with forward direction having priority over reverse direction.

Wiring example

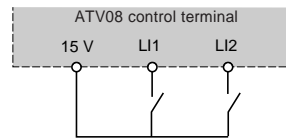

LI1 : Forward
LI2 : Reverse

3-wire control

Function : controls the operating direction and stopping via pulsed contacts.
Enable : via 2 or 3 logic inputs (1 or 2 operating directions).

Motor frequency

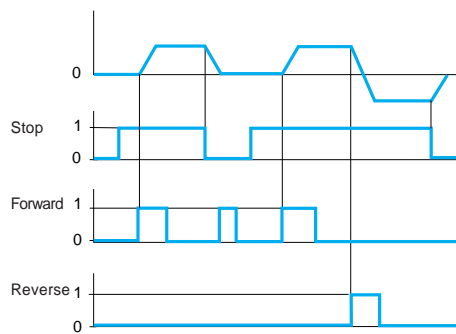

Wiring example

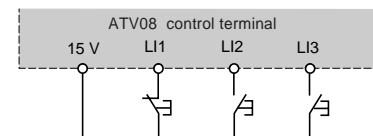

LI1 : Stop
LI2 : Forward
LI3 : Reverse

Configuration of analogue input AI

Function : used to modify the characteristics of the analogue input.

Factory preset : 0-5 V.

Other values : 0-10 V or, with a 500 Ω external resistor : 0-20 mA or 4-20 mA.

Variable speed controllers for asynchronous motors

Presentation :
pages 8 and 9
Characteristics :
pages 10 and 11
References :
pages 12 and 13
Dimensions, schemes :
pages 14 and 15

Altivar 08

Functions (cont.)

Preset speeds

Function : switching of preset speed references. Choice of either 2 or 4 preset speeds.
Enable : 1 or 2 logic inputs

Example with 4 speeds

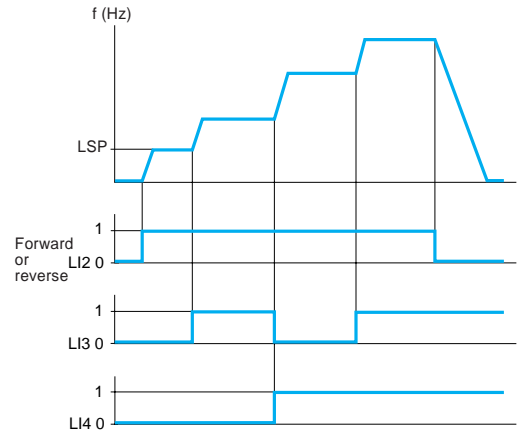

Speed achieved with inputs LI3 and LI4 at state 0 : LSP or speed reference depending on the level of analogue input AI.
Adjustment of preset speeds from 0.5 Hz to maximum frequency.

d.c. injection braking

Functions :

- braking to a standstill by d.c. injection (0.5 to 0 Hz)
 - the injection current is adjustable from 0.25 I_n to I_n
 - the injection time is adjustable from 0 (function disabled) to 20 s or continuous. If the injection time is continuous the adjusted current is divided by 2 after 30 s.

Variable speed controllers for asynchronous motors

Presentation :
pages 8 and 9
Characteristics :
pages 10 and 11
References :
pages 12 and 13
Dimensions, schemes :
pages 14 and 15

Altivar 08

Functions (cont.)

Automatic restart

Function : providing the operating conditions permit, automatic restart of the speed controller on the disappearance of certain types of faults listed below.

Faults which allow automatic restart :

- motor thermal overload
- speed controller thermal overload
- supply undervoltage
- overvoltage due to excessive deceleration, supply overvoltage (in these two cases, the speed controller restarts if the fault has disappeared at least one minute after it appeared)

If six faults which can be reset occur within a six minute period, the speed controller remains locked.

There are three possible configurations :

- automatic restart inactive
- automatic restart active for supply undervoltage only
- automatic restart active for all faults listed above

This function requires the speed reference and operating direction to be maintained.
It is reserved for fans, pumps and conveyor systems.

Fault relay, unlocking

The fault relay energises when the speed controller is powered up and there are no faults present.

The speed controller is unlocked after a fault by :

- switching speed controller off for at least 1 minute and then switching it on again
 - using the "automatic restart" function if it has been configured
-

Thermal protection of the motor

Function : indirect thermal protection of the motor by continuous calculation of its theoretical overheating.
The controller locks on a fault if overheating exceeds 118 % of nominal heating.

The microprocessor calculates theoretical overheating using two different elements :

- current absorbed by the motor
- operating time

The thermal memory is reset to zero by the microprocessor if the supply to the speed controller is interrupted.

40 °C is considered to be the maximum ambient temperature around the motor.

Adjustment :

- 0.45 to 1.2 times the nominal speed controller current
 - set to the nominal current shown on the motor rating plate
-

Thermal protection of the speed controller

Function : direct protection via a thermistor attached to the heatsink, providing protection for components even in the event of poor ventilation or excessive ambient temperature.
The speed controller locks if there is a fault.

Our Company's policy is one of continuous development and improvement and we reserve the right to supply products which may differ from those illustrated in this catalogue .

All our products are sold subject to our standard Conditions of Sale, copies of which are available on request.
© Schneider Limited 1999