

HIGH PERFORMANCE  
ALL-DIGITAL, SUPER LOW NOISE  
GENERAL PURPOSE INVERTER DRIVES

**G3+**

ADJUSTABLE FREQUENCY  
AC DRIVES

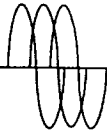

**Effective for General Purpose EPROM's  
through NSG616142 (E001046-32)**

200 TO 230V, 0.5 TO 125 HP (0.4 TO 75 kW)  
380 TO 460V, 0.5 TO 500 HP (0.4 TO 300 kW)  
500 TO 575V, 5 TO 225 HP (3.7 TO 160 kW)

©SAFTRONICS

0194 REV  
P/N X020075

1.0	Receiving .....	2
2.0	Installation .....	2
2.1	Dimensions .....	4
3.0	Wiring .....	5
3.1	Power Terminal Designation and Wire Size .....	6
3.2	Control Circuit Terminal Designation and Wiring .....	10
3.3	Molded Case Circuit Breaker, Input Fuse, and Magnetic Contact Sizing .....	11
3.4	General Wiring Practices .....	11
3.4.1	Main Circuit .....	11
3.4.2	Control Circuit .....	12
3.4.3	Grounding .....	12
3.4.4	General Start-up Caution .....	12
4.0	Using the Digital Operator .....	13
5.0	Inverter Constants .....	17
5.1	Un Constants .....	17
5.2	An Constants .....	19
5.3	bn Constants .....	19
5.3.1	bn Constants Description .....	20
5.4	Sn Constants .....	23
5.4.1	Sn Constants Description .....	26
5.5	Cn Constants .....	60
5.5.1	Cn Constants Description .....	62
6.0	Using the Digital Operator for Programming .....	79
7.0	Basic Programming for Start-up .....	82
8.0	Basic Programming for External Controls .....	85
9.0	Fault Indications .....	91
10.0	Elementary Diagram Description .....	94
11.0	Elementary Diagrams .....	96
12.0	Trouble Shooting Guide .....	99
13.0	Spare Parts List .....	106
14.0	Warranty .....	111

**1.0 RECEIVING:**

The Saftronics G3+ unit has been put through demanding tests at the factory prior to shipment. After unpacking, please inspect the following:

- Verify the Part Numbers on packing slip/Invoice match the unit part numbers.
- Check for physical damage immediately. If any part of the unit is damaged or missing, notify shipper immediately.

**Nameplate Data: Example**

<b>Model:</b> CIMR-G3U40P7	<b>Spec:</b> 40P71E
AC Input	AC Output
<b>Volts:</b> 380-460 Hz 50/60	<b>Volts:</b> 0-460 Hz 0 - 400
	<b>Phase:</b> 3 <b>Amps:</b> 2.9
<b>Phase:</b> 3 <b>Amps:</b> 3.2	<b>HP:</b> 1.0 <b>KVA:</b> 2.2

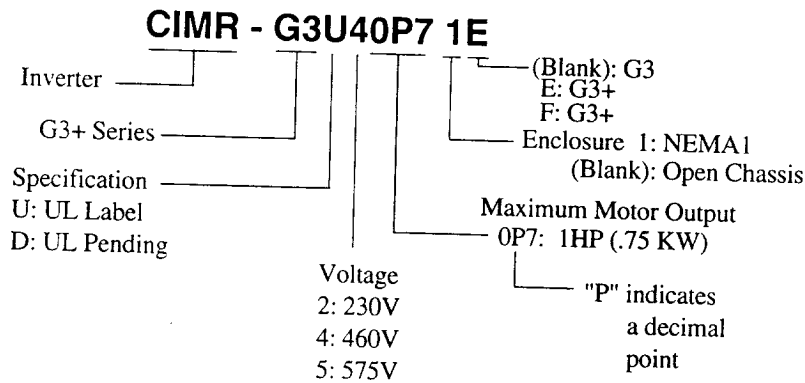

**2.0 INSTALLATION:**

**Location**

Location of this unit is important to achieve proper performance and normal operating life. The G3 unit should be installed where the following conditions exist.

1. Ambient Temp. Enclosed type +14° F to 104° F(-10°C to 40°C)  
Open Chassis type +14° F to 113° F(-10° to 45°C)
2. Protected from rain and moisture.
3. Protected from direct sunlight.
4. Protected from corrosive or explosive gases or liquids.
5. Free from airborne dust or metallic particles.
6. Free from vibrations.
7. Free from magnetic noise.
8. In relative humidity of less than 95% non-condensation

# SAFTRONICS

## 2.0 INSTALLATION (CONTINUED)

### Mounting Space:

... Install G3+ unit vertically and allow sufficient space for cooling as shown on Fig. 1

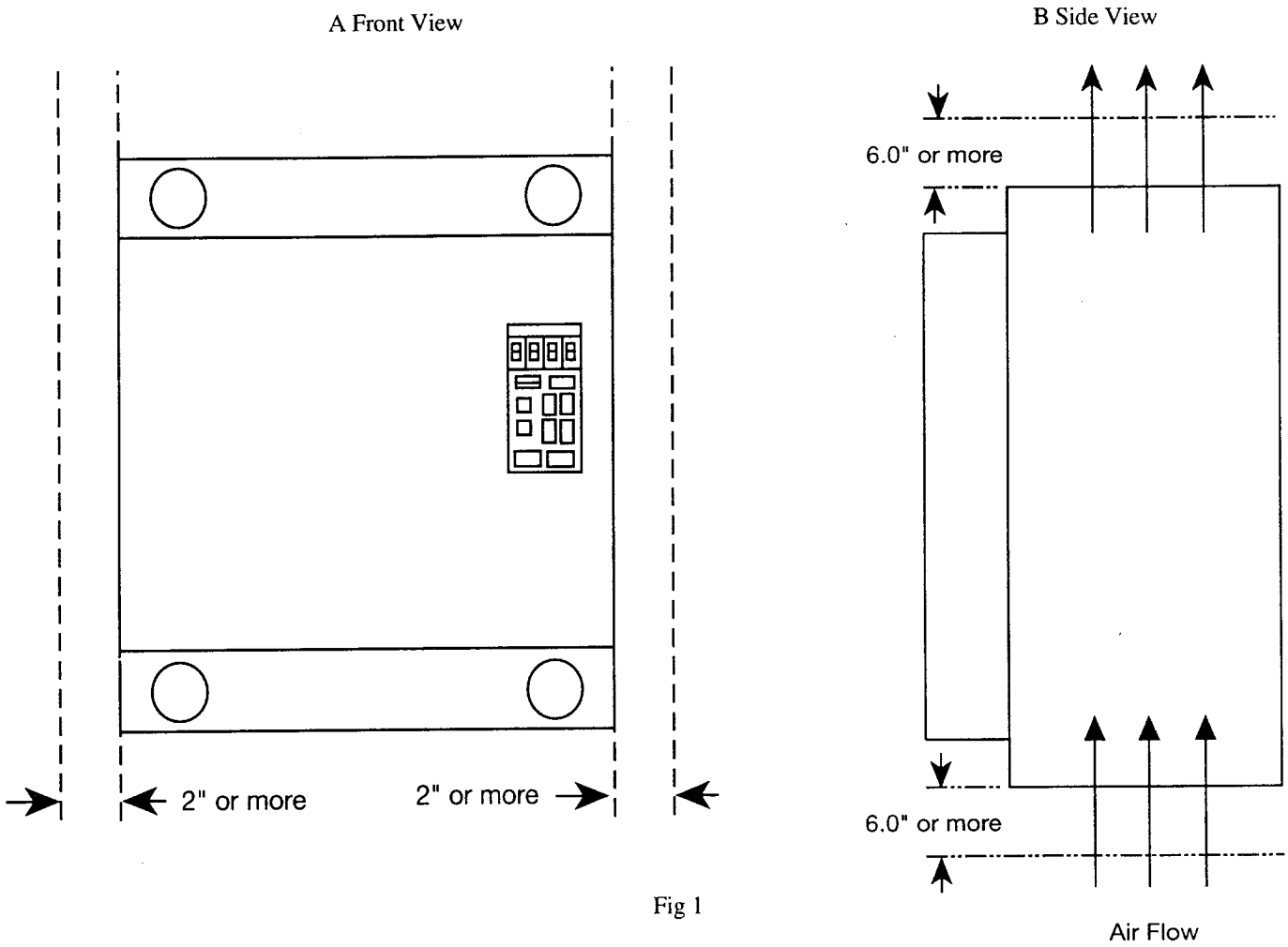
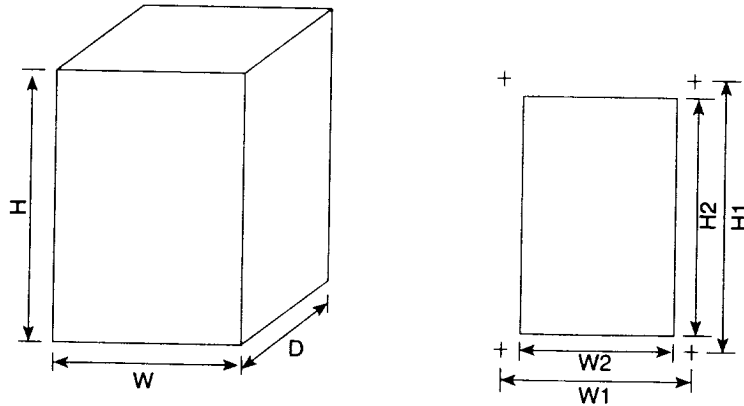

Fig 1

2.1 Dimensions



Series	Model	Dimensions (Inches)							Weight (lbs.)
		W	H	D	Mounting		Cutout		
					W1	H1	W2	H2	
230V	20P4, 20P7, 21P5	8.05	11.97	5.12	7.09	11.22	7.76	10.28	9
	22P2, 23P7	8.05	11.97	6.50	7.09	11.22	7.76	10.67	15
	25P5, 27P5	8.05	13.94	7.87	7.09	13.19	7.76	12.60	22
	2011	11.81	23.62	9.84	11.02	19.69	9.17	18.58	73
	2015	14.76	25.59	9.65	13.98	21.65	12.09	20.43	73
	2018	18.50	27.56	10.24	17.52	23.62	12.00	20.77	101
	2022	18.50	29.13	10.24	17.52	23.62	12.00	20.77	101
	2030 (1)	16.73	26.57	11.02	12.40	25.79	15.94	25.00	114
	2037 (1)	18.70	31.50	11.02	14.76	30.71	17.91	28.35	132
	2045, 2055 (1)	18.70	31.50	11.02	14.76	30.71	17.91	28.35	146
	2075 (1)	23.62	50.39	17.83	21.65	49.02	22.05	43.90 (3)	343
460V	40P4, 40P7, 41P5, 42P2	8.05	13.94	6.50	7.09	13.19	7.76	12.60	15
	43P7, 45P5, 47P5	8.05	13.94	7.88	7.09	13.19	7.76	12.60	22
	4011, 4015	11.81	23.62	10.31	11.02	19.69	9.37	18.54	73
	4018, 4022	18.50	27.56	10.39	17.52	23.62	12.01	19.78	101
	4030, 4037, 4045	19.29	34.45	11.26	18.31	30.52	13.15	25.47	137
	4L45	25.98	44.29	11.26	24.80	39.37	19.06	33.07	227
	4055 (1)	22.64	36.42	11.02	18.70	35.43	21.85	32.60	197
	4075 (1)	22.64	36.42	11.02	18.70	35.43	21.85	32.60	207
	4110 (1)	22.64	36.42	12.99	18.70	35.43	21.85	32.95	233
	4160 (1)	23.62	53.54	17.83	21.65	52.17	22.05	47.05	381
	4185, 4220 (1)	37.40	57.09	17.13	(2)	55.12	32.91	48.90 (3)	806
	4300 (1)	37.97	62.99	17.91	(2)	61.02	34.37	54.92 (3)	941
575V	53P7, 55P5, 57P5 (1)	12.80	21.65	11.61	10.43	21.06	12.01	19.49 (3)	75
	5011, 5015, 5018 (1)	15.75	29.53	11.22	11.81	28.74	15.16	26.46 (3)	99
	5022, 5030, 5037 (1)	20.67	32.48	12.99	16.73	31.50	20.08	29.21	155
	5045, 5055 (1)	22.83	37.40	13.98	18.90	36.42	22.20	34.13	222
	5075, 5090 (1)	22.64	49.21	12.99	18.70	48.23	20.55	45.67 (3)	269
	5110, 5160 (1)	22.64	62.99	13.98	18.70	61.81	20.55	58.66 (3)	336

(1) Open chassis configuration. (2) 6 mounting holes. (3) Additional cutout required.

## 3.0 WIRING:

Typical Interconnection Diagram  
FIG 3

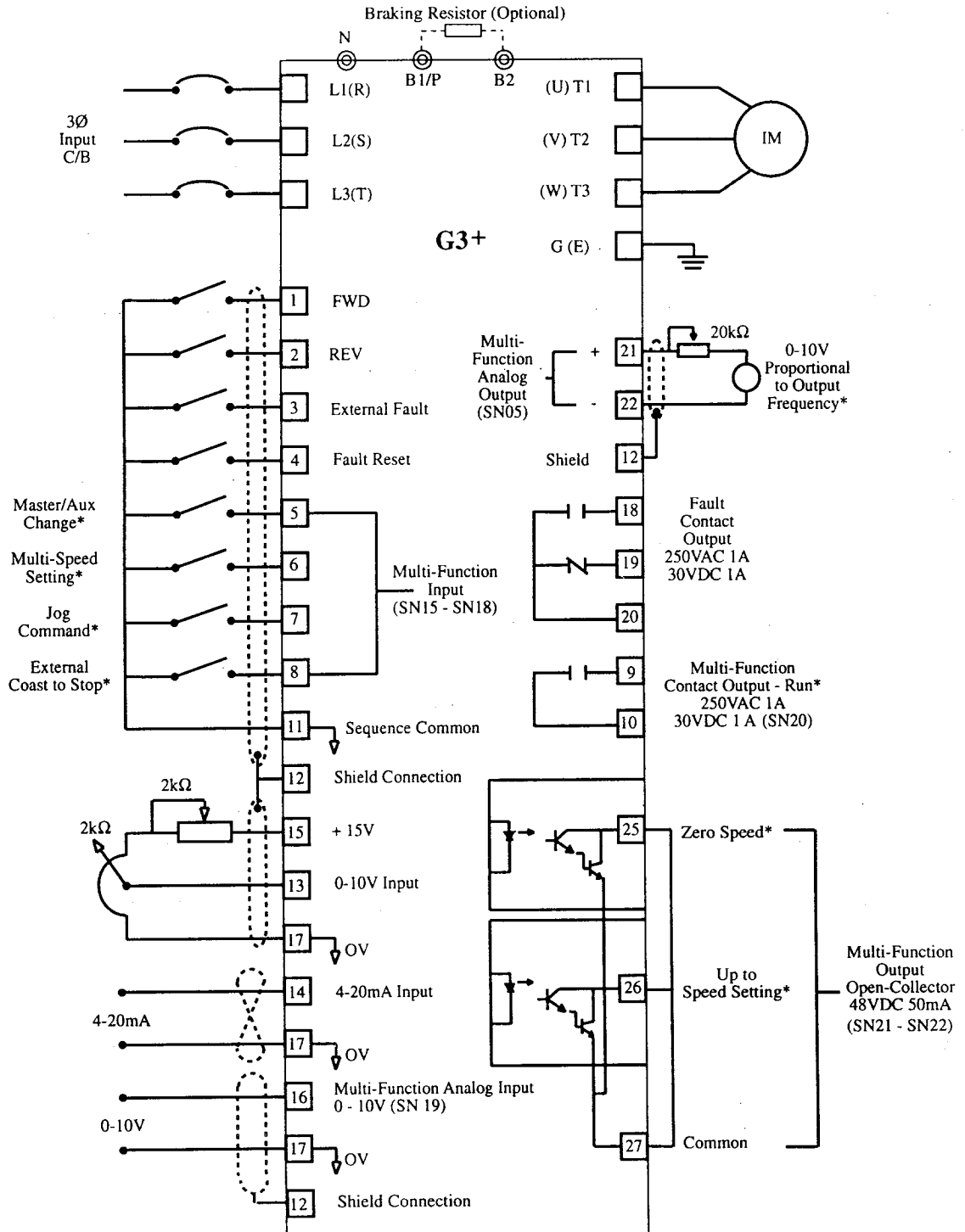

\*Factory Settings

**3.1 Power terminal designation and wire size:**

*Table 1 230V Class Wire Size*

Circuit	Model CIMR-G3U	HP CT VT	Terminal Symbol	Terminal Screw	75° C	Wire Type
					Copper Wire Range AWG	
Main	20P4	0.75 1	L1(R), L2(S), L3(T), ⊖, B1/⊕, B2, T1(U), T2(V), T3(W)	M4	14 - 10	Power Cable: 600V Vinyl Sheathed Lead or Equivalent
			G(E)		14 - 10	
	20P7	1 1.5	L1(R), L2(S), L3(T), ⊖, B1/⊕, B2, T1(U), T2(V), T3(W)	M4	14 - 10	
			G(E)		14 - 10	
	21P5	2 2	L1(R), L2(S), L3(T), ⊖, B1/⊕, B2, T1(U), T2(V), T3(W)	M4	14 - 10	
			G(E)		12 - 10	
	22P2	3 3	L1(R), L2(S), L3(T), ⊖, B1/⊕, B2, T1(U), T2(V), T3(W)	M4	14 - 10	
			G(E)		12 - 10	
	23P7	5 5	L1(R), L2(S), L3(T), ⊖, B1/⊕, B2, T1(U), T2(V), T3(W)	M4	10	
			G(E)		10	
	25P5	7.5 7.5	L1(R), L2(S), L3(T), ⊖, B1/⊕, B2, T1(U), T2(V), T3(W)	M5	8	
			G(E)		10	
	27P5	10 10	L1(R), L2(S), L3(T), ⊖, B1/⊕, B2, T1(U), T2(V), T3(W)	M5	8	
			G(E)		10	
	2011	15 20	L1(R), L2(S), L3(T), BO/⊖, B1/⊕, T1(U), T2(V), T3(W)	M6	4	
			G(E)		* 8 - 2	
	2015	20 25	L1(R), L2(S), L3(T), BO/⊖, B1/⊕, T1(U), T2(V), T3(W)	M8	3 - 1/0	
			G(E)		* 8 - 2	
	2018	25 30	∅1(r), ∅2(s)	M4	14 - 10	
			L1(R), L2(S), L3(T), BO/⊖, B1/⊕, T1(U), T2(V), T3(W)		M8	
	2022	30 40	G(E)	M8	6 - 2	
			∅1(r), ∅2(s)		M8	
	2030**	40 50	L1(R), L2(S), L3(T), BO/⊖, B1/⊕, T1(U), T2(V), T3(W)	M8	1/0	
			G(E)		* 6 - 2	
2037**	50 60	∅1(r), ∅2(s)	M4	14 - 10		
		L1(R), L2(S), L3(T), ⊖, ⊕1, ⊕3, T1(U), T2(V), T3(W)		M10	2 - 4/0	
2045**	60 75	G(E)	M10	2 - 4/0		
		∅1(r), ∅2(s)		M4	20 - 14	
2055**	75 100	L1(R), L2(S), L3(T), ⊖, ⊕1, ⊕3, T1(U), T2(V), T3(W)	M10	2 - 4/0		
		G(E)		* 4 - 2		
2075**	100 125	∅1(r), ∅2(s)	M4	20 - 14		
		L1(R), L2(S), L3(T), ⊖, ⊕1, ⊕3, T1(U), T2(V), T3(W)		M10	2 - 4/0	
Control	Common to all models	1 - 32	M3.5	20 - 14	Twisted shielded lead with class 1 wiring or equal.	
		G(E)		* 3 - 2		

\* Indicates the use of Pressure Lug Terminals

\*\* Not Low Noise Version

**... IMPORTANT ...**

Voltage drop of leads should be considered  
when selecting wire size

# SAFTRONICS

## 3.1 Power terminal designation and wire size: (Continued)

Table 2 460V Class Wire Size

Circuit	Model CIMR-G3U	HP CT VT	Terminal Symbol	Terminal Screw	75° C Copper Wire Range	Wire Type	
					AWG		
Main	40P4	0.75 1	L1(R), L2(S), L3(T) ⊖ , B1 ⊕ , B2, T1(U), T2(V), T3(W)	M4	14 - 10	Power Cable: Sheathed Lead or equivalent	
			G(E)		14 - 10		
	40P7	1 1.5	L1(R), L2(S), L3(T) ⊖ , B1 ⊕ , B2, T1(U), T2(V), T3(W)	M4	14 - 10		
			G(E)		14 - 10		
	41P5	2 2	L1(R), L2(S), L3(T) ⊖ , B1 ⊕ , B2, T1(U), T2(V), T3(W)	M4	14 - 10		
			G(E)		14 - 10		
	42P2	3 3	L1(R), L2(S), L3(T) ⊖ , B1 ⊕ , B2, T1(U), T2(V), T3(W)	M4	14 - 10		
			G(E)		14 - 10		
	43P7	5 5	L1(R), L2(S), L3(T) ⊖ , B1 ⊕ , B2, T1(U), T2(V), T3(W)	M4	14 - 10		
			G(E)	M5	12 - 10		
	45P5	7.5 7.5	L1(R), L2(S), L3(T) ⊖ , B1 ⊕ , B2, T1(U), T2(V), T3(W)	M4	12 - 10		
			G(E)	M5	12 - 10		
	47P5	10 10	L1(R), L2(S), L3(T) ⊖ , B1 ⊕ , B2, T1(U), T2(V), T3(W)	M4	10		
			G(E)	M5	10		
	4011	15 20	L1(R), L2(S), L3(T) ⊖ , B1 ⊕ , B2, T1(U), T2(V), T3(W)	M5	8		
			G(E)	*	10 - 2		
	4015	20 25	L1(R), L2(S), L3(T), B1 ⊖ , B2 ⊕ , T1(U), T2(V), T3(W)	M5	8		
			G(E)	*	10 - 2		
	4018	25 30	ℓ1(r), ℓ2(s)	M4	14 - 10		
			L1(R), L2(S), L3(T), B1 ⊖ , B2 ⊕ , T1(U), T2(V), T3(W)	M6	6 - 4		
	4022	30 40	G(E)	*	8 - 2		
			ℓ1(r), ℓ2(s)	M4	14 - 10		
	4030	40 50	L1(R), L2(S), L3(T), B1 ⊖ , B2 ⊕ , T1(U), T2(V), T3(W)	M6	4		
			G(E)	*	8 - 2		
4037	50 60	ℓ1(r), ℓ2(s)	M4	14 - 10			
		L1(R), L2(S), L3(T), B1 ⊖ , B2 ⊕ , T1(U), T2(V), T3(W)	M8	3 - 1/0			
**4045	60 75	G(E)	*	8 - 2			
		ℓ1(r), ℓ2(s)	M4	14 - 10			
4L45	60 75	L1(R), L2(S), L3(T), B1 ⊖ , B2 ⊕ , T1(U), T2(V), T3(W)	M8	1/0			
		G(E)	*	6 - 2			
						M4	14 - 10

\* Indicates the use of Pressure Lug Terminals

\*\* Not Low Noise Version

**.. IMPORTANT ..**

Voltage drop of leads should be considered  
when selecting wire size



**3.1 Power terminal designation and wire size: (Continued)**

*Table 2 460V Class Wire Size*

Circuit	Model CIMR-G3U	HP CT VT	Terminal Symbol	Terminal Screw	75° C Copper Wire Range		Wire Type
					AWG		
Main	**4055	75	L1(R), L2(S), L3(T), ⊖, B1/⊕, B2 ⊕, T1(U), T2(V), T3(W)	M10	2 - 4/0	Power Cable: Sheathed Lead or equivalent	
			G(E)	*	4 - 2		
		100	∅1(r), ∅2 200 (∅200), ∅2 400 (∅400), x, y	M4	20 - 14		
	**4075	100	L1(R), L2(S), L3(T), ⊖, B1/⊕, B2 ⊕, T1(U), T2(V), T3(W)	M10	2 - 4/0		
			G(E)	*	4 - 2		
		150	∅1(r), ∅2 200 (∅200), ∅2 400 (∅400), x, y	M4	20 - 14		
	**4110	150	L1(R), L2(S), L3(T), ⊖, B1/⊕, B2 ⊕, T1(U), T2(V), T3(W)	M10	2 - 4/0		
			G(E)	*	3 - 2		
		200	∅1(r), ∅2 200 (∅200), ∅2 400 (∅400), x, y	M4	20 - 14		
	**4160	200	L1(R), L2(S), L3(T), ⊖, B1/⊕, B2 ⊕, T1(U), T2(V), T3(W)	M12	4/0-MCM400		
			G(E)	*	1 - 2/0		
		250	∅1(r), ∅2 200 (∅200), ∅2 400 (∅400), x, y	M4	20 - 14		
	**4185	250	L1(R), L2(S), L3(T), ⊖, ⊕1, ⊕3, T1(U), T2(V), T3(W)	M12	MCM650x2P		
			G(E)	*	1/0 - 2/0		
		300	∅1(r), ∅2 200 (∅200), ∅2 400 (∅400), x, y	M4	20 - 14		
	**4220	300	L1(R), L2(S), L3(T), ⊖, ⊕1, ⊕3, T1(U), T2(V), T3(W)	M12	MCM650x2P		
			G(E)	*	1/0 - 2/0		
		400	∅1(r), ∅2 (∅)	M4	20 - 14		
**4300	400	L1(R), L2(S), L3(T), ⊖, ⊕1, ⊕3, T1(U), T2(V), T3(W)	M12	MCM650x2P			
		G(E)	*	2/0			
	500	∅1(r), ∅2 (∅)	M4	20 - 14			
Control	Common to all models		I - 32	M 3.5	20 - 14		

\* Indicates the use of Pressure Lug Terminals

\*\* Not Low Noise Version

**.. IMPORTANT ...**

Voltage drop of leads should be considered  
when selecting wire size

# SAFTRONICS

## 3.1 Power terminal designation and wire size: (Continued)

Table 3 575V Class Wire Size

Circuit	Model CIMR-G3U	HP CT VT	Terminal Symbol	Terminal Screw	75° C Copper Wire Range		Wire Type
					AWG		
Main	53P7	5	L1(R), L2(S), L3(T), ⊖, B1/⊕, B2, T1(U), T2(V), T3(W)	M5	14 - 10		Power Cable: Sheathed Lead or equivalent
			G(E)		14 - 10		
	55P5	7.5	∅1, ∅2 x y	M4	20 - 14		
			L1(R), L2(S), L3(T), ⊖, B1/⊕, B2, T1(U), T2(V), T3(W)	M5	12 - 10		
	57P5	10	G(E)	M8	14 - 10		
			∅1, ∅2 x y	M4	20 - 14		
	5011	15	L1(R), L2(S), L3(T), ⊖, B1/⊕, B2, T1(U), T2(V), T3(W)	M5	12 - 10		
			G(E)	M4	14 - 10		
	5015	20	∅1, ∅2, x y	M8	20 - 14		
			L1(R), L2(S), L3(T), ⊖, B1/⊕, B2, T1(U), T2(V), T3(W)	M6	10 - 8		
	5018	25	G(E)	M8	14 - 10		
			∅1, ∅2, x y	M4	20 - 14		
	5022	30	L1(R), L2(S), L3(T), ⊖, B1/⊕, B2, T1(U), T2(V), T3(W)	M6	10 - 8		
			G(E)	M8	14 - 10		
	5030	40	∅1, ∅2, x y	M4	20 - 14		
			L1(R), L2(S), L3(T), B0/⊖, B1/⊕, T1(U), T2(V), T3(W)	M8	8 - 14		
	5037	50	G(E)	M8	14 - 10		
			∅1, ∅2, x y	M4	20 - 14		
	5045	60	L1(R), L2(S), L3(T), B0/⊖, B1/⊕, T1(U), T2(V), T3(W)	M8	22 - 38		
			G(E)	M8	14 - 10		
	5055	75	∅1, ∅2, x y	M4	20 - 14		
			L1(R), L2(S), L3(T), B0/⊖, B1/⊕, T1(U), T2(V), T3(W)	M8	22 - 38		
	5075**	100	G(E)	M8	14 - 10		
			∅1, ∅2, x y	M4	20 - 14		
5090**	150	L1(R), L2(S), L3(T), B0/⊖, B1/⊕, T1(U), T2(V), T3(W)	M10	60 - 150			
		G(E)	M8	14 - 10			
5110**	200	∅1, ∅2, x y	M4	20 - 14			
		L1(R), L2(S), L3(T), B0/⊖, B1/⊕, T1(U), T2(V), T3(W)	M12	100 - 200			
5160**	225	G(E)	M8	14 - 10			
		∅1, ∅2, x y	M4	20 - 14			
Control	Common to all models		1 to 32	M 3.5	20 - 14	Twisted shielded lead with class I wiring or equivalent	

**IMPORTANT**

Voltage drop of leads should be considered when selecting wire size

\* Indicates the use of Pressure Lug Terminals

\*\* Not Low Noise Version

**3.2 Control Circuit Terminals and Wiring**

*Table 4*

Term Number	Terminal Function	Signal	Type of Wire
1	FWD Run by latched contact	+24 VDC 8mA Input	Twisted Shielded Wire 18-14 AWG
2	REV Run by latched contact		
3	External Fault Input		
4	External Fault Reset		
5	Multi-Function Input (Sn15-Sn18)		
6			
7			
8			
9	Multi-Function Output (Sn20)		
10			
11	Sequence Input Common (OV)		
12	Shield connection term. (G)		Shield Connect.
13	0-10VDC master freq. ref.	0-10V 20KΩ	Twisted Shielded 18-14 AWG
14	4-20mA master freq. ref.	4-20mA 250Ω	
15	+15VDC power supply for speed	+15V 20mA load	
16	Multi-Function analog input 0-10VDC	0-10V/100% 20K	
17	G (OV)	OV	
18	N.O. fault contact	Output contact 250 VAC 1A 30 VDC 1A	
19	N.C. fault contact		
20	Fault contact common		
21	+Multi-function analog output	0-10 VDC	
22	-Multi-function analog output (Sn05)		
25	Multi-function open collector Output No. 1 (Sn21)	Open Collector 48 VDC, 50mA	
26	Multi-function open collector Output No. 2 (Sn22)		
27	Multi-function open collector Output common		

Note: There are no terminals numbered 23 and 24.

\*Noise suppressors **must** be used on all coils of magnetic contactors, relays, magnetic valves, magnetic relays, etc., that are near the control wiring or drive unit.

UNIT	SPECIFICATION	PART NUMBER
Lg. Magnetic Contactor	.47ufd + 100Ω	C500016
Control Relay		

# SAFTRONICS

## 3.3 Molded Case Circuit Breaker (MCCB), Input Fuses and Magnetic Contactor Sizing

When a ground fault interrupt is used, select one with a high frequency rejection capability, setting current should be 200mA or over, and an operating limit of 1 second to prevent nuisance trips.

If a magnetic contactor (MC) is used, NEVER use the MC to start or stop the drive. Otherwise, premature drive failure may occur.

If a shunt trip is used on the MCCB, when tripped the motors will coast to stop.

If used, input fuses should be Gould Shawmut class AJT or equivalent.

Use Table 5, 6 or 7 for sizing MCCB, input fuse, and MC.

**Table 5**

230 V Series	
Model G3U	Rated Current
20P4	6A
20P7	10A
21P5	20A
22P2	20A
23P7	30A
25P5	50A
27P5	60A
2011	100A
2015	100A
2018	150A
2022	150A
2030	225A
2037	225A
2045	300A
2055	400A
2075	600A

**Table 6**

460V Series	
Model G3U	Rated Current
40P4	5A
40P7	5A
41P5	10A
42P2	10A
43P7	20A
45P5	20A
47P5	30A
4011	50A
4015	60A
4018	80A
4022	100A
4030	100A
4037	150A
4045	150A
4L45	150A
4055	225A
4075	300A
4110	400A
4160	600A
4185	600A
4220	800A
4300	1000A

**Table 7**

575V Series	
Model G3U	Rated Current
53P7	20A
55P5	20A
57P5	20A
5011	30A
5015	50A
5018	60A
5022	60A
5030	100A
5037	100A
5045	100A
5055	150A
5075	225A
5090	225A
5110	300A
5160	400A

## 3.4 General Wiring Practices

### 3.4.1 Main Circuit

This unit is not input phase sensitive, input phasing rotation does not affect output motor direction.

If motor rotation does not match the keypad digital display, interchange any 2 of the output leads (T1, T2, T3).

Never connect AC main to output power terminals T1, T2, T3.

Never connect power factor correction capacitor to output T1, T2, T3. Never use capacitor start motor on G3 units.

Never open or close output contactor while drive is running. Wiring distance should not exceed 164 ft. from inverter to motor. (Consult factory)

**3.4 General Wiring Practices (Continued)**

**3.4.2 Control Circuit**

Always use specified wire type on all control wiring (see sec. 3.1).

Separation of all control wiring from main wiring **must** be done through separate conduit.

Wiring distance should not exceed 164 feet from inverter to control station.

All shields should be connected to terminal 12 as shown in Fig. 4.

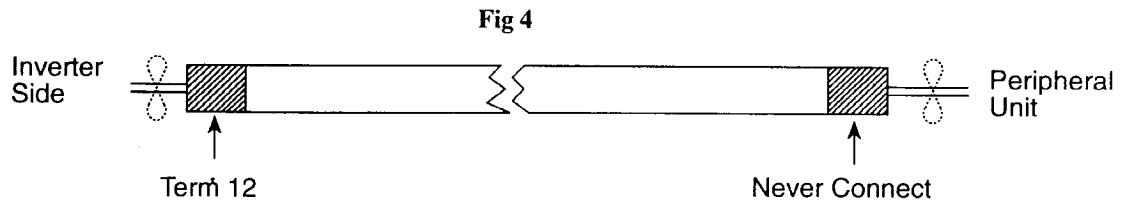

**3.4.3 Grounding**

Ground wire should be connected to G3+ term G (E).

Ground leads should be less than 100 Ohm resistance.

Use ground leads which comply with AWG standards and make length as short as possible.

Never ground G3+ in common with welding machines, motors, and other large current electrical equipment.

When grounding multiple units side by side, the following practices should be observed (See Fig 5).

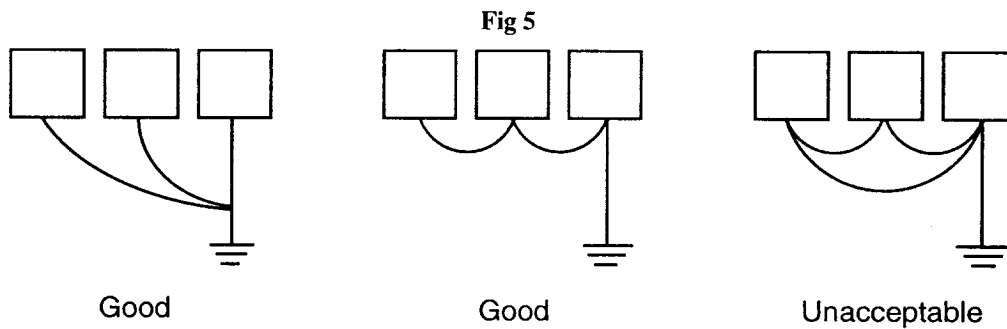

**3.4.4 General Start-Up Caution**

**CAUTION**

All Potentiometers of G3+ units have been set at factory. **DO NOT CHANGE SETTINGS.**

Do not conduct dielectric test to unit. Disconnect motor to conduct motor megger test.

Control PC board uses CMOS IC's which are static sensitive. **DO NOT TOUCH CMOS ELEMENTS.**

Do not connect or disconnect wires or connectors while power is on.

**4.0 USING THE DIGITAL OPERATOR**

The Saftronics G3+ Inverter when received as a stand alone unit out of the box is programmed to run from the digital display key pad.

**Fig 6**

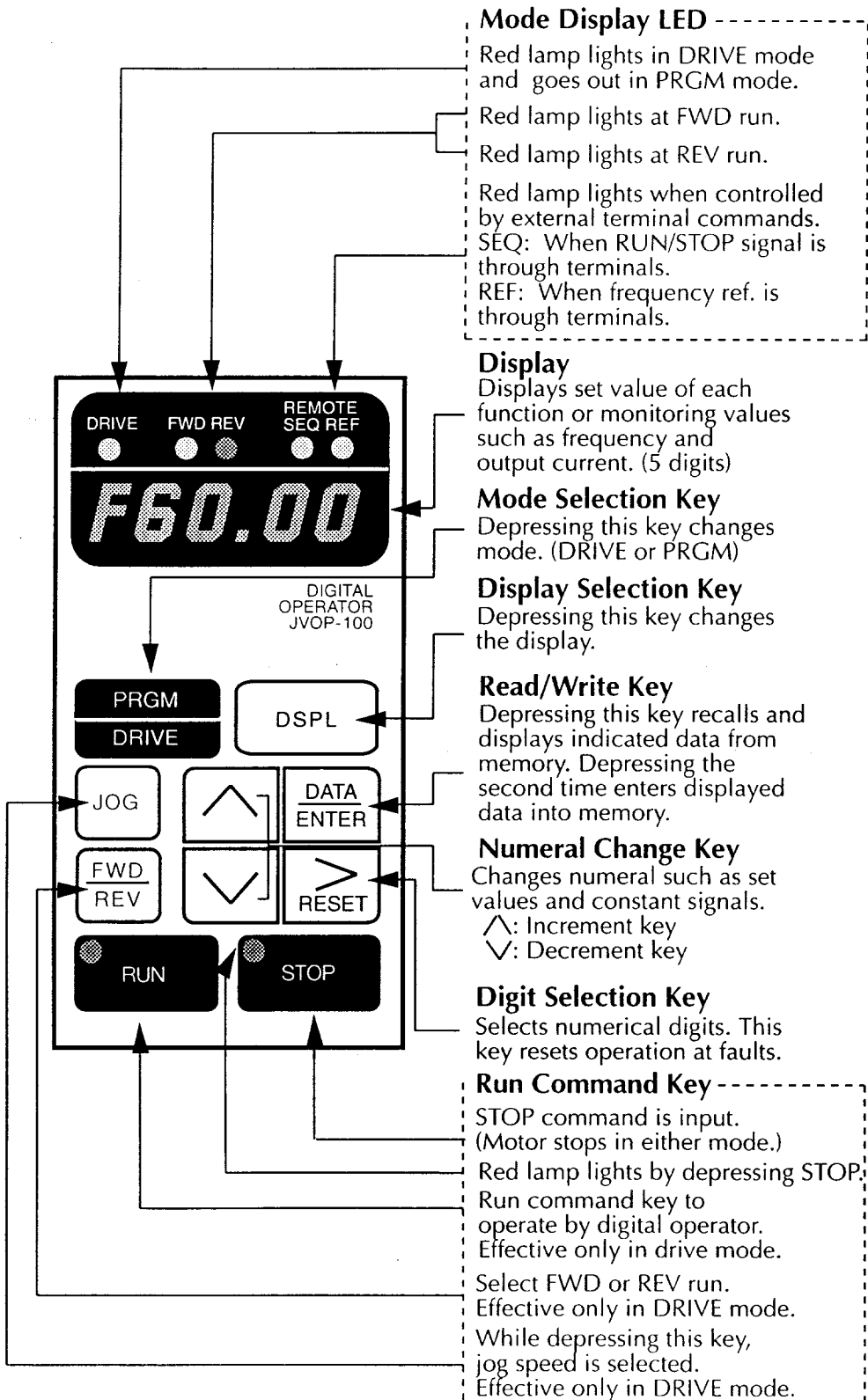

**4.0 USING THE DIGITAL OPERATOR (CONTINUED)**

After power up. LED's should be per Table 8:

*Table 8*

Drive LED	ON
FWD LED	ON
REV LED	OFF
Remote Seq.	OFF
Remote Ref.	OFF
Run LED	OFF
Stop LED	ON

**Digital Read Out**

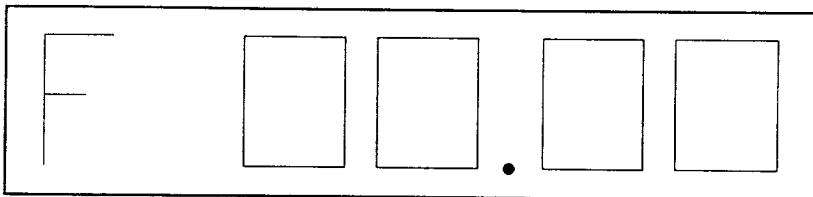



**Run Mode**

With above screen showing, use the  key, to move the flashing digit to the 10's position

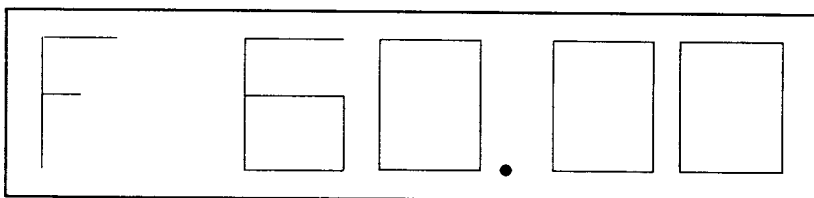
and use  key to set the desired frequency



Press the  key, the digital display flashing will stop momentarily.





Then press the  key.

The stop LED will go out and the run LED will come on the drive will start accelerating to 60Hz.

# SAFTRONICS

## 4.0 USING THE DIGITAL OPERATOR (CONTINUED)

### To Change Speed:

Use the  key to move the flashing digit to the position desired, then use the  and / or the  key to set the desired output frequency, then press the  and the drive will then accelerate or decelerate to the new frequency setting.

### To Stop:

Press the  key, the stop LED will come on, the run LED will begin flashing, and will continue flashing until the drive output frequency reaches 0 Hz.

### Programming:







By depressing the  key you can access 7 monitor or control functions

Table 9

KEY OPERATION	DESCRIPTION	READ-OUT EXAMPLE
	Reference frequency (Speed reference input)	F 60.00
	Output frequency (Output Speed)	60.00
	Output Current	3.4A
	Fault Record**	U I U U
	Displays 10 monitor functions	Un - 0
	9 programmable pre-set speeds	An - 0
	12 programmable drive constants	bn - 0

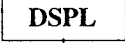
\*\* When no fault has occurred, this display is skipped.

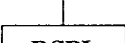
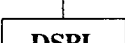

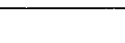
---

**4.0 USING THE DIGITAL OPERATOR (CONTINUED)**

---

**NOTE!**

Digit order is explained in the following diagram. This format will be used throughout the entire manual.

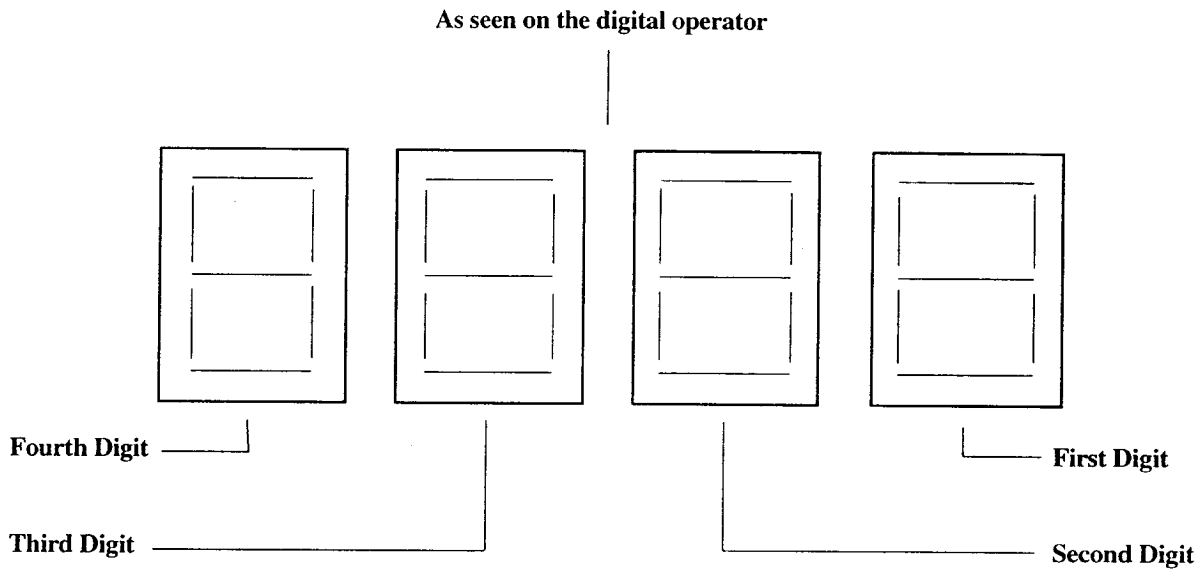

# SAFTRONICS

## 5.0 INVERTER CONSTANTS

### 5.1 Un Constants

Un constants can be accessed while the drive is running for monitoring drive functions

Table 10

UN	MONITOR ITEM	EXAMPLE READ-OUT
01	Frequency reference	60.00
02	Output frequency	60.00
03	Output current	12.5A
04	Output voltage	230u
05	DC bus voltage	Pn 325
06	Output power	2.5 (1)
07	Input term status	(2)
08	Output term status	(3)
09	Display LED check	(4)
10	PROM No.	10140

(1) Un06 display of output power "kW" units will not appear on display. Display is in units of 0.1kW (+/-).

(2) Un07 display of input terminal status .

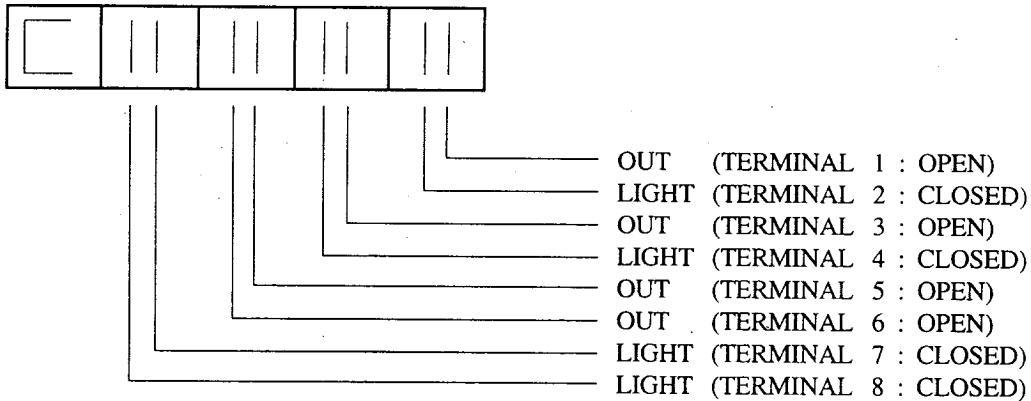

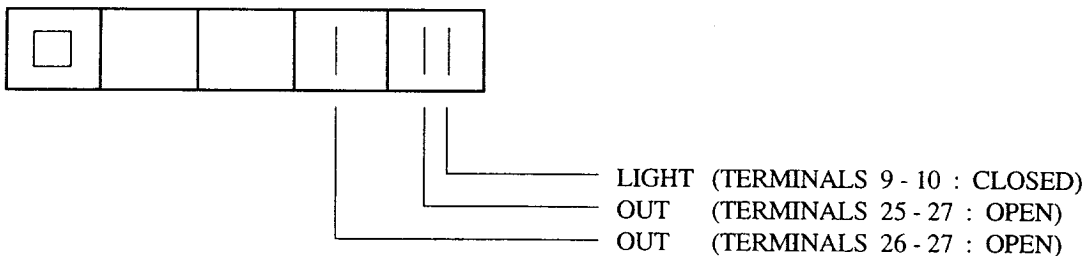

(3) Un08 display of output terminal status



(4) Un09 LED lamp check . All LED's should light.

5.1 Un Constants (Continued)

Un constants can be displayed while the drive is running to monitor different drive conditions.

- 1. Press **DSPL** key until **Un-01** is displayed.
- 2. Use the  and / or the  key to get to the desired Un monitor function.
- 3. When Un constant number that you want is displayed, press the **DATA ENTER** key.

EXAMPLE  (Displayed)

Press **DSPL** (Press the **DSPL** key until Un-01 is displayed)

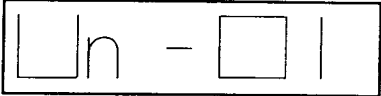
 (Displayed)

Press   (Press appropriate key to display Un number you desire to monitor)

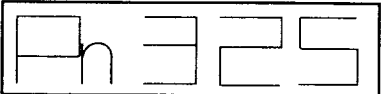

Press **DATA ENTER**

 (DC bus voltage)

**DSPL** To exit, then press the **DSPL** key and scroll to desired display

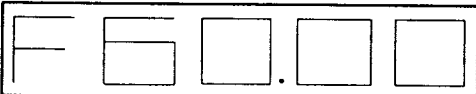

# SAFTRONICS

## 5.2 An-Constants

The An constants are 9 pre-settable speed references which may be used for multi-speed operation. They can be displayed and changed while the drive is running.

List of An -

Table 11

An- <input type="checkbox"/> <input type="checkbox"/>	Data Name	Unit	Setting Range	Factory Setting
01	Frequency reference 1	0.01 Hz	0.00 Hz - 400.00 Hz	0.00 Hz
02*	Frequency reference 2	0.01 Hz	0.00 Hz - 400.00 Hz	0.00 Hz
03	Frequency reference 3	0.01 Hz	0.00 Hz - 400.00 Hz	0.00 Hz
04	Frequency reference 4	0.01 Hz	0.00 Hz - 400.00 Hz	0.00 Hz
05	Frequency reference 5	0.01 Hz	0.00 Hz - 400.00 Hz	0.00 Hz
06	Frequency reference 6	0.01 Hz	0.00 Hz - 400.00 Hz	0.00 Hz
07	Frequency reference 7	0.01 Hz	0.00 Hz - 400.00 Hz	0.00 Hz
08	Frequency reference 8	0.01 Hz	0.00 Hz - 400.00 Hz	0.00 Hz
09	Frequency reference 9	0.01 Hz	0.00 Hz - 400.00 Hz	6.00 Hz

\* An-02 is effective only when Sn-19 is not set to 0.

Refer to Sn15 through Sn18 on page 45 for a detailed explanation of multi-speed selection.

## 5.3 bn - Constants

The bn - Constants are 12 programmable drive parameters that can be displayed and changed while the drive is running for fine tuning.

List of bn -

Table 12

bn - <input type="checkbox"/> <input type="checkbox"/>	Data Name	Unit	Setting Range	Factory Setting
01	Acceleration time 1	0.1 Sec	0.0-6000.0 Sec	10.0 Sec
02	Deceleration time 1	0.1 Sec	0.0-6000.0 Sec	10.0 Sec
03	Acceleration time 2	0.1 Sec	0.0-6000.0 Sec	10.0 Sec
04	Deceleration time 2	0.1 Sec	0.0-6000.0 Sec	10.0 Sec
05	Frequency reference gain	0.1%	0-1000.0%	100%
06	Frequency reference bias	1%	-100 to 100%	0%
07	Torque compensation gain	0.1	0.0-2.0	1.0
08	Motor rated slip	0.1%	0.0-9.9%*	0.0%
09	Energy-saving level gain	1%	0-200%	80%
10	Monitor No. after turning on power supply	—	1-3	1
** 11	Gain of analog output (ter. 21 and 22) and gain of channel 1 of option card if installed	0.01	0.00-2.55	1.00
** 12	Gain of channel 2 of option card if installed	0.01	0.00-2.55	0.5

\* Cn-04 is regarded as 100% level.

\*\* Effective only when Option Cards AO-08 or AO-12 are used.

**5.3.1 bn Constants Description**

**bn-01 : Acceleration Time 1**

Sets acceleration time in 0.1 second increments from 0Hz to maximum output frequency (Cn-02).

**bn - 02 : Deceleration Time 1**

Sets deceleration time in 0.1 second increments from maximum output frequency (Cn-02) to 0Hz.

**bn-03 : Acceleration Time 2**

Sets alternate acceleration time in 0.1 second increments. Accessible through setting value 07 into SN-15, 16, 17, or 18 and closing a contact to the appropriate terminal 5, 6, 7, or 8. See page 46 for setting procedure.

**bn-04 : Deceleration Time 2**

Sets alternate deceleration time in 0.1 second increments. Accessible through setting value 07 into SN-15, 16, 17, or 18 and closing a contact to the appropriate terminal 5, 6, 7, or 8. See page 46 for setting procedure.

**bn-05 : Frequency Reference Gain**

Sets frequency reference gain in % level (10V/XX%) when frequency reference voltage is 10 V. Refer to the following graph.

**bn-06 : Frequency reference Bias**

Sets frequency reference bias in 1 % unit. Refer to the following graph.

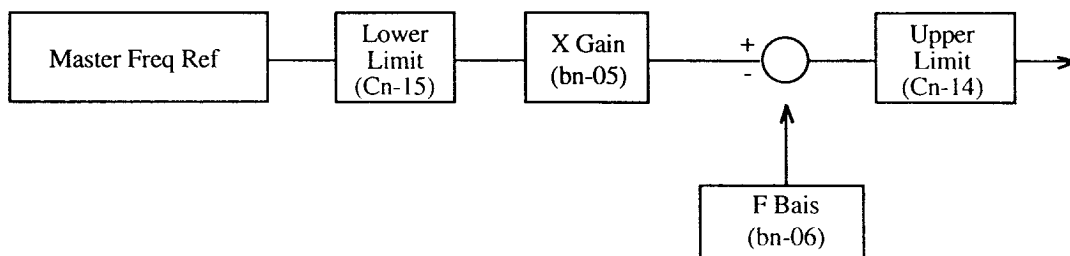
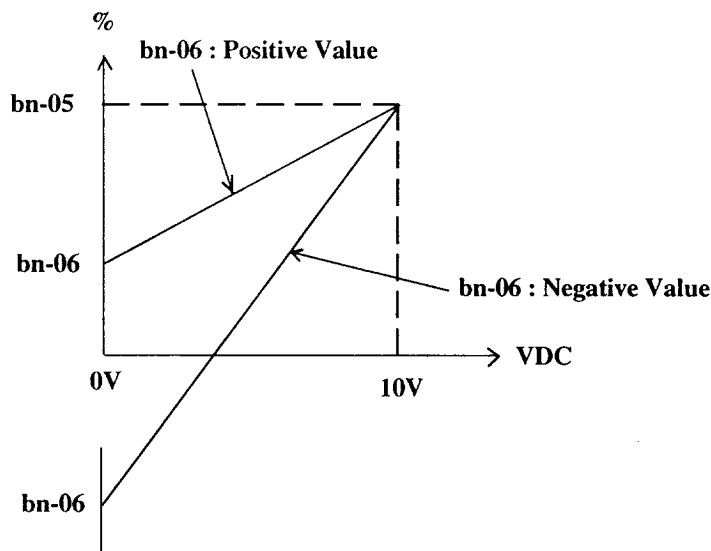

## 5.3.1 bn Constants Description (Continued)

### bn-07: Torque Compensation Gain

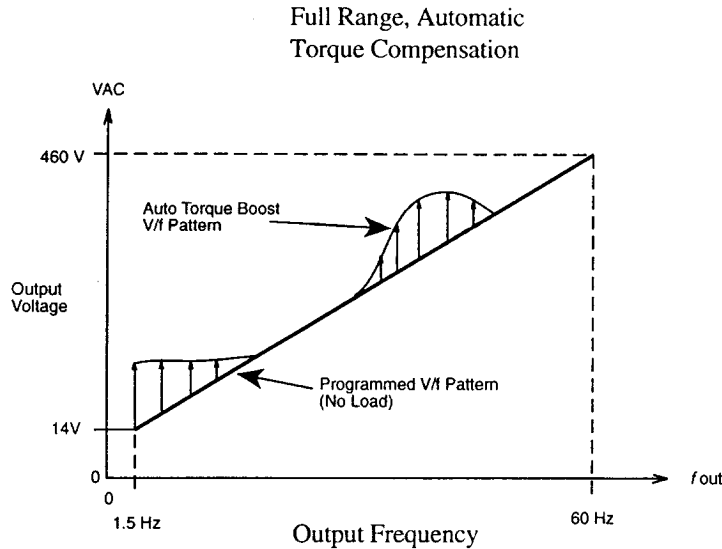

This circuit monitors output current, frequency and voltage, to automatically boost output voltage. This circuit is very useful where high starting torque is required or where shock loading occurs. Adjust this circuit by selecting a standard V/f pattern and increase bn07 value by 0.1 increments until sufficient torque is achieved.

### bn-08 : Motor Rated Slip

For slip compensation circuit  
Output frequency:

$$\frac{\text{motor rated slip}}{(\text{motor rated current}) - (\text{No-load current})} \times (\text{Output current} - \text{No-load current})$$

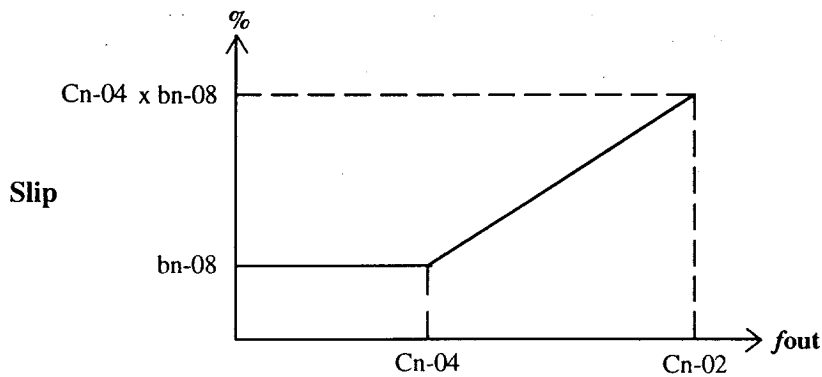

#### Frequency

Cn-02 = Maximum Frequency

Cn-04 = Maximum Voltage Frequency

This function is similar to IR compensation in a DC drive and will allow a standard NEMA Design B squirrel cage induction motor to achieve approximately 1% speed regulation in an open loop configuration.

**5.3.1 bn Constants Description (Continued)****bn-09 : Energy-Saving Level Gain**

Allows for reduced output voltage during running under lightly loaded conditions. This function can help to eliminate motor/system vibration.

Accessible through setting value 63 into SN-15, 16, 17, or 18 and closing a contact to the appropriate terminal 5, 6, 7, or 8. See page 51 for setting procedure.

---

**bn-10 : Monitor Data on Power-up**

This constant lets you set the order in which the data is displayed.

- 1) Frequency reference
  - 2) Output frequency
  - 3) Output current
- 

**bn-11 : Analog Monitor Channel Gain**

Set Gain of multi-function analog output terminals 21 and 22 or Channel 1 of AO-08 and AO-12.  
10V = XX%

Example

Setting bn-11 to 200, sets 5V to equal 100%.

---

**bn-12 : Analog Monitor Channel 2 Gain**

Same as bn-11 for Channel 2 of option cards AO-08 and AO-12.

## 5.4 System Constant Sn - □□

Sn-	Data Name	SYSTEM CONSTANT Sn- □□□□				Factory Setting					
		Function		4th digit	3rd digit	2nd digit	1st digit	4	3	2	1
01	Inverter Capacity	Inverter capacity selected. Values differ from model to model.								Page 26	
02	V/f	V/f pattern selected (refer to page 27, 28)								0 1	
03	Display of Operator	0000	Setting and reading of An-0000, bn-0000, Sn-0000, Cn-0000 enabled							0 0 0 0	
	Constants Initialization	0101	Setting and reading of An-0000, bn-0000, Sn-0000, Cn-0000 enable								
04	Operation Method Select	1110	Master Reset (2 wire)							0 0 1 1	
		1111	Master Reset (3 Wire)								
		Master frequency reference by analog input of external terminals 13, 14		—	—	—	0				
		Master frequency reference from keypad		—	—	—	1				
	External terminal operation effective (start/stop, etc)		—	—	0	—					
	Keypad operation effective		—	—	1	—					
	Stopping Method Select	RAMP stop		0	0	—	—				
		Coasting to stop		0	1	—	—				
Full-range DC injection braking stop		1	0	—	—						
Coasting stop (timer function provided)		1	1	—	—						
05	Priority of Stopping	Keypad STOP key effective during operation		—	—	—	0	0 0 0 0			
		Keypad STOP key not effective during operation		—	—	—	1				
	Prohibition of REV run	REV run enabled		—	—	0	—				
		REV run disabled		—	—	1	—				
	Control Input Scan	Control input are scanned twice before being accepted by MPU		—	0	—	—				
		Control input are scanned once before being accepted by MPU		—	1	—	—				
	Analog Monitor Output	Analog output (terminals 21- 22) selection (#1)		0	—	—	—				
		Analog output (terminals 21- 22) selection (#1)		1	—	—	—				
06	S-curve at accel/decel time	0.2 sec S-curve		—	—	0	0	0 0 0 0			
		No S-curve		—	—	0	1				
		0.5 sec. S-curve		—	—	1	0				
		1.0 sec. S-curve		—	—	1	1				
	Input Reference	Response to master frequency reference: 0 to 100% for 0 to 10V (4 to 20mA)		—	0	—	—				
		Response to master frequency reference: 0 to 100% for 10 to 0V (20 to 4mA)		—	1	—	—				
	Processing When Frequency Reference is Missing	Stop by reference input loss		0	—	—	—				
		Operation to continue with 80% of frequency reference		1	—	—	—				
Not used		0	—	—	—						
07	Overtorque Detection	Overtorque detection not enabled		—	—	—	0	0 0 0 0			
		Overtorque detection enabled		—	—	—	1				
		Enable only if at set speed		—	—	0	—				
		Enable during operation (except during DC injection)		—	—	1	—				
		Operation continued after overtorque is detected		—	0	—	—				
		Coasts to stop if overtorque is detected		—	1	—	—				
	Not used		0	—	—	—					
08	Priority of Frequency Reference (When input option card is used)	Frequency reference is from option card (if installed)		—	—	—	0	0 1 0 0			
		Frequency reference is from inverter (Sn-04)		—	—	—	1				
	Priority of Run Command (When input option card is used)	Run Command is from option card (if installed)		—	—	0	—				
		Run command is from inverter		—	—	1	—				
	Stopping Method Selection at Communication Interface Card (SI-B)	Ramp to a stop by bn-02		0	0	—	—				
		Coast to stop		0	1	—	—				
		Ramp to a stop by bn-04		1	0	—	—				
Communication Error	Operation to continue		1	1	—	—					
	Analog Output Selection Method	Analog output (terminals 21-22) depends on Sn-05 4th digit and Sn-09 2nd digit		—	—	—	0	0 0 0 0			
		Analog output (terminals 21-22) is set by communication interface card (SI-B)		—	—	—	1				
Analog Monitor Selection	Analog output (terminals 21-22) selection (*1)		—	—	0	—					
	Analog output (terminals 21-22) selection (*1)		—	—	1	—					
Not used		0	0	—	—						



5.4 System Constants Sn - □ □ (Continued)

Sn-	Data Name	System Constant Sn-□□				Factory Setting					
		Function				4th digit	3rd digit	2cd digit	1st digit	4	3
10	Stall Prevention	Stall prevention during acceleration enabled		-	-	-	0	0	0	0	0
		Stall prevention during acceleration disabled		-	-	-	1				
		Stall prevention during deceleration enabled		-	-	0	-				
		Stall prevention during deceleration disabled		-	-	1	-				
		Stall prevention during running enabled		-	0	-	-				
		Stall prevention during running disabled		-	1	-	-				
		Decel time during stall prevention : "DECEL TIME 1" (bn-02 set value)		0	-	-	-				
Decel time during stall prevention : "DECEL TIME 2" (bn-04 set value)		1	-	-	-						
11	DB resistor	No DB protection calculated or provided by inverter		-	-	-	0	0	0	0	0
		Protection provided for internal DB resistor only, if installed		-	-	-	1				
	Fault Contact during Auto Reset/Restart Operation	Fault contact is not energized during auto reset/restart operation		-	-	0	-				
		Fault contact is energized during auto reset/restart operation		-	-	1	-				
	Momentary Power Loss Protection	Operation stopped by momentary power loss detection		-	0	-	-				
Operation continues during momentary power loss		-	1	-	-						
—		Not used		0	-	-	-				
12	External Fault Signal Level	External fault input ; Normal open-contact input		-	-	-	0	0	1	0	0
		External fault input ; Normal closed-contact input		-	-	-	1				
	Receiving External Fault Signal	External fault signal ; always detected		-	-	0	-				
		External fault signal ; detected while running only		-	-	1	-				
	Processing at External Fault Detection	Ramp stop (major fault)		0	0	-	-				
		Coasting to stop (major fault)		0	1	-	-				
Emergency stop (major fault) decelerates to stop by emergency stop time (bn-04 set value)		1	0	-	-						
—		Operation to continue (minor fault)		1	1	-	-				
13	Stopping Method at Fan Fault Detection (*2)	Not used		-	-	0	0	0	0	0	0
		Deceleration to stop by bn-02		0	0	-	-				
		Coast to stop		0	1	-	-				
		Deceleration to stop by bn-04		1	0	-	-				
		Operation to continue		1	1	-	-				
14	Motor Protection (Electronic Thermal)	Electronic thermal motor protection effective		-	-	-	0	0	0	0	0
		Electronic thermal motor protection ineffective		-	-	-	1				
		Electronic thermal characteristics are in accordance with standard motor		-	-	0	-				
		Electronic thermal characteristics are in accordance with constant torque motor		-	-	1	-				
		Electronic thermal characteristics are standard		-	0	-	-				
		Electronic thermal characteristics are short-time rating		-	1	-	-				
	Inverter Protection (Electronic Thermal) (*2)	Inverter Protection OL: 103% continuous, 150% for one minute		0	-	-	-				
		Inverter Protection OL: 113% continuous, 123% for one minute		1	-	-	-				
15	Terminal 5 Function	00-FF	Selects terminal 5 function (factory set for multi-step speed reference1)				0 3				
16	Terminal 6 Function	00-FF	Selects terminal 6 function (factory set for multi-step speed reference2)				0 4				
17	Terminal 7 Function	00-FF	Selects terminal 7 function (factory set for jog frequency reference)				0 6				

# SAFTRONICS

## 5.4 System Constants - □□ (Continued)

18	Terminal 8 Function	00-FF	Selects terminal 8 function (factory set for internal baseblock by NO contact input)	0	8							
19	Multi-function Analog Input	00-FF	Selects multi-function analog input (terminal 16) function	0	0							
20	Multi-function Output 1	00-FF	Selects multi-function contact output (terminals 9, 10) function (factory set for during running)	0	0							
21	Multi-function Output 2	00-FF	Selects multi-function open collector (terminal 25) function (factory set for zero speed)	0	1							
22	Multi-function Output 3	00-FF	Selects multi-function open collector (ter. 26) function (factory set for speed agreed setting)	0	2							
25	Analog Reference Card (AI-14B)	Positive/negative values of frequency reference determine FWD / REV operation		-	-	-	0	0	0	0	0	
		Positive frequency reference value determine forward operation; negative = 0 output		-	-	-	1					
	Not used		0	0	0	-						
26	Digital Reference Card (DI - 08) (Frequency reference set mode)	BCD input 1 % Resolution		0	0	0	0	0	0	0	0	
		BCD input 0.1 % Resolution		0	0	0	1					
		BCD input 0.01 % Resolution		0	0	1	0					
		BCD input 1 Hz Resolution		0	0	1	1					
		BCD input 0.1 Hz Resolution		0	1	0	0					
		BCD input 0.01 Hz Resolution		0	1	0	1					
		BINARY input 255 / 100%		0	1	1	1					
BINARY input (input value displayed in decimal on operator)		1	0	0	0							
27	Digital Output Card (DO-08)	DO-08 output signal combination 1 (output data fixed)		-	-	-	0	0	0	1	0	
		DO-08 output signal combination 2 (encoded output)		-	-	-	1					
	Pulse Monitor Card (PO-36F) (NO. of Output Pulses)	1F		0	0	0	-					
		6F		0	0	1	-					
		10F		0	1	0	-					
		12F		0	1	1	-					
36F		1	0	0	-							
28	Analog Monitor Card (AO-08, AO-12)	Channel 1 output	Output frequency (max. frequency /100%)		-	-	0	0	0	1	0	0
			Output current (rated current /100%)		-	-	0	1				
			Output voltage ref. (Input voltage / 100%)		-	-	1	0				
			DC voltage 400V /100% for 230V class 800V /100% for 460V class 1000V/100% for 575V class		-	-	1	1				
		Channel 2 output	Output frequency (max. frequency / 100%)		0	0	-	-				
			Output current (rated current / 100%)		0	1	-	-				
			Output voltage ref. (Input voltage / 100%)		1	0	-	-				
			DC voltage 400V / 100% for 230V class 800V / 100% for 460V class 1000V/100% for 575V class		1	1	-	-				

(\*1) Setting of Sn-05 4th digit and Sn-09 2nd digit.

Sn-05 4th digit	Sn-09 2nd digit	Description
0	0	Output analog signal proportional to inverter output frequency. (Max frequency/100%)
1	0	Output analog signal proportional to inverter output current. (Rated current/100%)
0	1	Output analog signal proportional to inverter output voltage reference. (Cn-01/100%)
1	1	Output analog signal proportional to inverter output power. (Max applicable motor capacity/100%)

(\*2) Effective for models 2030-2075, 4055-4300, and 5022-5160 only.

**5.4.1 Sn Constants Description**

**Sn-01 - Inverter Capacity Selection**

This constant must be set to correspond to the inverter capacity.

<b>230 Series Inverter</b>		<b>460 Series Inverter</b>		<b>575 Series Inverter</b>	
<u>Model #</u>	<u>Sn-01 Data</u>	<u>Model #</u>	<u>Sn-01 Data</u>	<u>Model #</u>	<u>Sn-01 Data</u>
20P4	00	40P4	20	53P7	44
20P7	01	40P7	21	55P5	45
21P5	02	41P5	22	57P5	46
22P2	03	42P2	23	5011	47
23P7	04	43P7	24	5015	48
25P5	05	45P5	25	5018	49
27P5	06	47P5	26	5022	4A
2011	07	4011	27	5030	4B
2015	08	4015	28	5037	4C
2018	09	4018	29	5045	4D
2022	0A	4022	2A	5055	4E
2030	0B	4030	2B	5075	4F
2037	0C	4037	2C	5090	50
2045	0D	4045	2D	5110	51
2055	0E	4L45	3F	5160	52
2075	0F	4055	2E		
		4075	2F		
		4110	31		
		4160	33		
		4185	34		
		4220	35		
		4300	36		

# SAFTRONICS

## 5.4.1 Sn Constants Description (Continued) Sn-02 : V/f Pattern Selection

	Specification	Sn02	V/f Pattern		Specification	Sn02	V/f Pattern
<b>General Purpose</b>	50 Hz Saturation	00		<b>Variable Torque (Fans and Pumps)</b>	60Hz Variable Torque 1	06	
	60 Hz Saturation (Factory Setting)	01			60Hz Variable Torque 2	07	
	50 Hz Saturation	02			50Hz Starting Torque 1	08	
	72 Hz Saturation	03			<b>*High Starting Torque</b>	50Hz Starting Torque 2	09
<b>Variable Torque (Fans and Pumps)</b>	50Hz Variable Torque 1	04		60Hz Starting Torque 1		0A	
	50Hz Variable Torque 2	05		60Hz Starting Torque 2		0b	

5.4.1 Sn Constants Description (Continued)  
 Sn-02 : V/f Pattern Selection (Continued)

Constant HP Operation (Machine Tools)	Specification	Sn02	V/f Pattern
	90 Hz Saturation	0C	
	120 Hz Saturation	0d	
	180 Hz Saturation	0E	

- NOTE:**
1. Double voltages shown for 460 volt series inverters.
  2. For 575 volt series inverters, multiply voltages shown by 2.5.
  3. Consider the following items when selecting a V/f Pattern:
    - A. The voltage and frequency characteristics of motor.
    - B. Maximum speed of motor.

\* Select High Starting Torque for the following conditions:

1. Motor leads distance is long.
2. Voltage drop at start up is large. (Soft line)
3. When using a smaller motor than inverter rating.

**NOTE:** High starting torque V/f Patterns are not normally required. Use a general purpose V/f Pattern and use torque compensation circuit (bn 07), and increase bn 07's value in increments of 0.1 until sufficient torque is achieved.

# SAFTRONICS

## 5.4.1 Sn Constants Description (Continued)

### Sn-03: Operator Status

Factory setting = 0000

Setting of Sn-03 will determine which constants can be read or written to.

Sn-03	Drive Mode		Program Mode	
	Setting enabled	Reading only	Setting enabled	Reading only
0000	An-, bn-	Sn-, Cn-	An-, bn-, Sn-, Cn-	————
0101	An-	bn-, Sn-, Cn-	An-	bn-, Sn-, Cn-
1110	————		2-wire control initialized	
1111	————		3-wire control initialized	

**NOTE:** 1110 and 1111 are factory resets. All constants except Sn-01 and Sn-02 are reset to factory. After successful reset, END will be displayed on digital operator. Setting of 3-wire control also changes function of multi-function input terminals.

### Sn-04 - Digit 1: Run Mode Selection #1

Factory setting = 1

Digit 1 = 0: Output frequency is set through the external terminal number 13 or 14

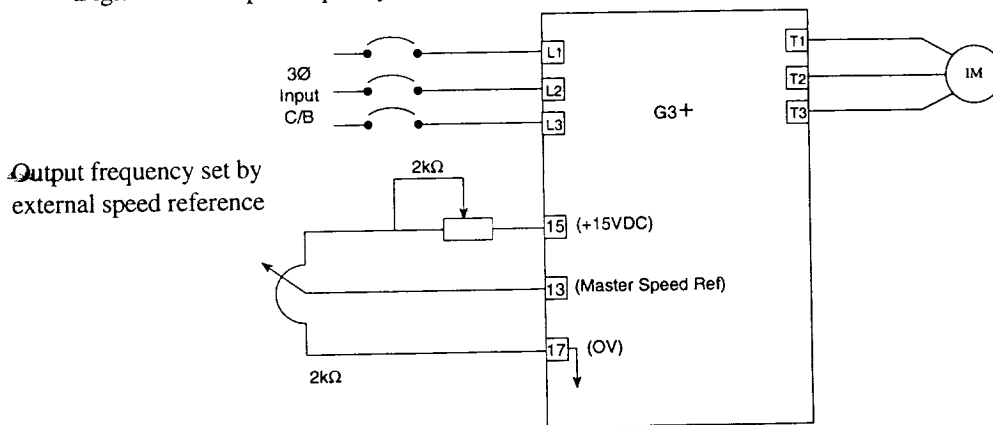

Digit 1 = 1: The output frequency is set through the Digital Operator.

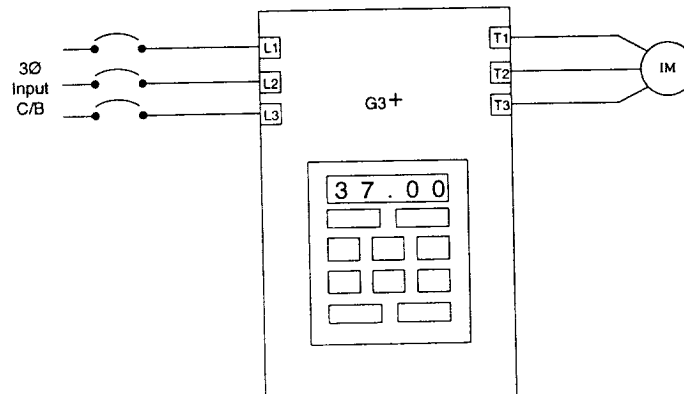

**5.4.1 Sn Constants Description (Continued)**

**Sn-04 (Continued) Digit 2**

Factory setting = 1

Digit 2 = 0: Run commands through the external terminals.

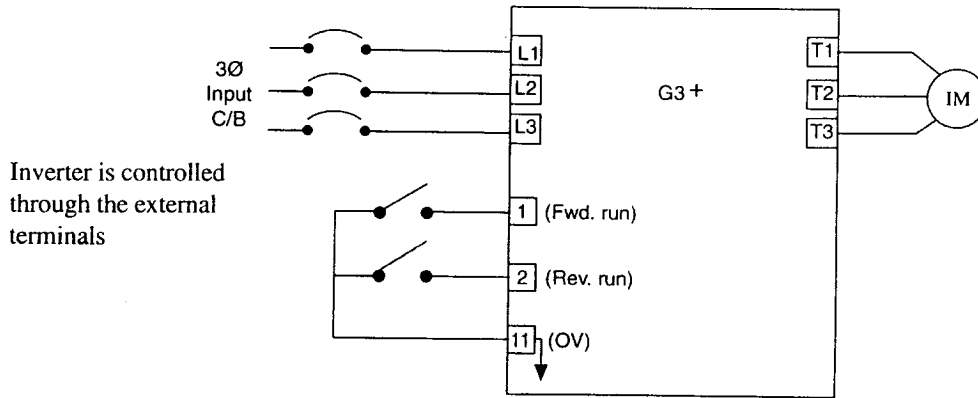

**NOTE:** Maintained contacts

Digit 2 = 1: Run commands through the keypad.

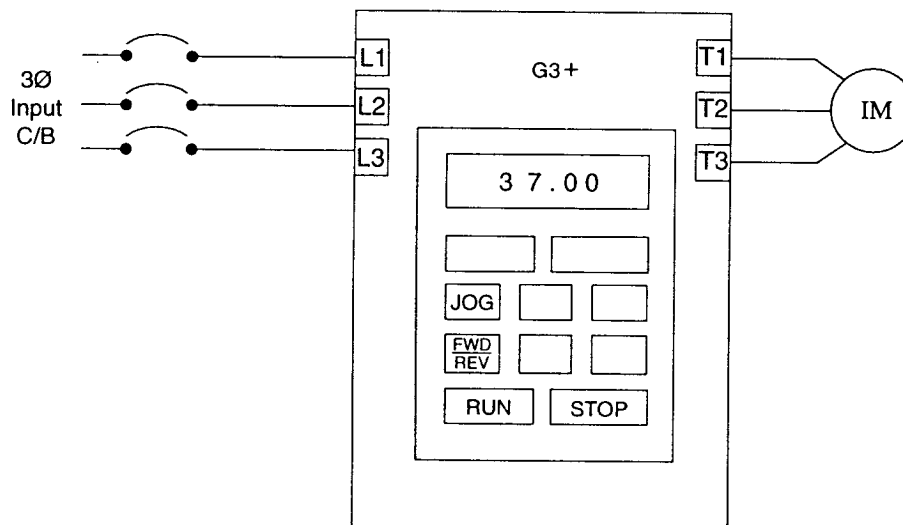

## 5.4.1 Sn Constants Description (Continued)

### Sn-04 (Continued) Digit 3 and 4: Stopping Method Selection

Factory setting = 00

Digit 3 and 4 = 00: Deceleration to stop

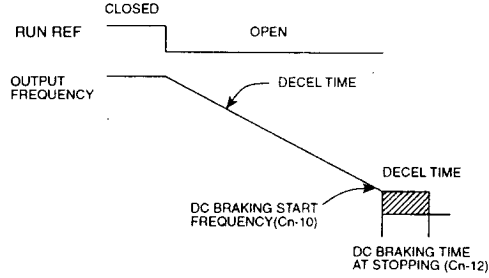

Digit 3 and 4 = 01: Coast to a stop

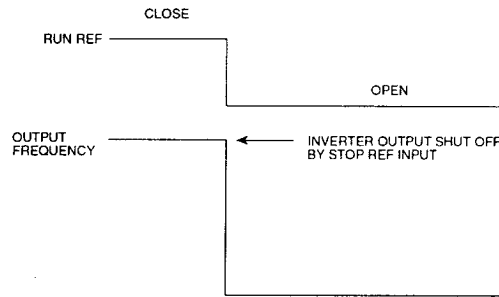

Digit 3 and 4 = 10: D.C. injection braking from stop signal

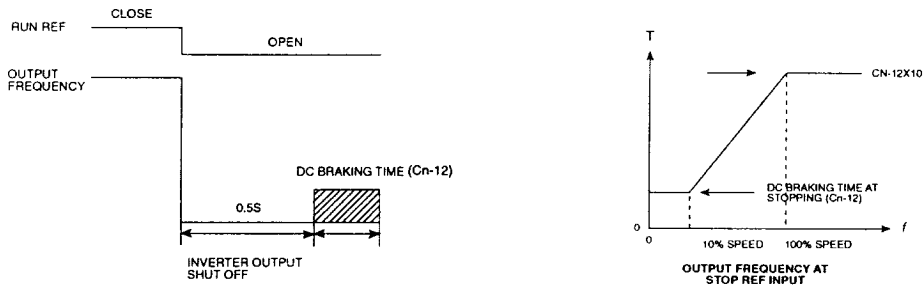

Digit 3 and 4 = 11: Coast to stop with timer function (restartable after the deceleration time in bn-02 elapses).

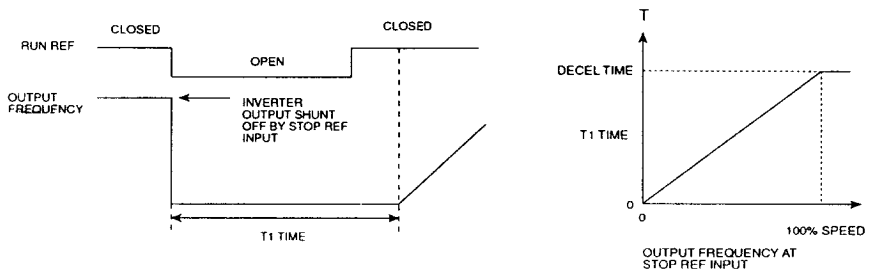



**5.4.1 Sn Constants Description (Continued)****Sn-05 Digit 1: Priority of Stopping**

Factory Setting = 0000

Digit 1=0: The keypad STOP key is effective even during operation from the external terminals. When the STOP key is depressed, the operation stops according to the setting of System Constant Sn-04 Digits 3 and 4. This stop command is held in the inverter until all external terminal run commands (forward run, reverse run, multi-step speed reference, jog, etc.) are open. The STOP key LED is blinking under this condition.

Digit 1=1: The keypad STOP key is ineffective during operation from the external terminals.

**Sn-05 Digit 2: Prohibition of REV Run**

Factory Setting = 0

Digit 2 = 0: Reverse run from the keypad or external terminals is effective.

Digit 2 = 1: Reverse run from the keypad or external terminals is ineffective.

**Sn-05 Digit 3: Control Input Scan**

Factory Setting = 0

Digit 3 = 0: External terminals 1 to 8 are scanned twice before accepting the sequence reference.

Digit 3 = 1: External terminals 1 to 8 are scanned once before accepting the sequence reference.

**Sn-05 Digit 4: Analog Monitor Output**

Factory Setting = 0

Digit 4 = 0: Analog output signal proportional to output frequency of 0-10VDC at 6-bit resolution is present at external terminals 21 and 22.

Digit 4 = 1: Analog output signal proportional to output current of 0-10VDC at 6-bit resolution is present at external terminals 21 and 22.

## 5.4.1 Sn Constants Description (Continued)

### Sn-06 Run Mode Selection #3 ("soft starting" functions)

Factory setting = 0000

Digit 1 and 2 = 00: S-curve is selected with a 0.2 second operation time (accel only).

Digit 1 and 2 = 01: S-curve function is not selected.

Digit 1 and 2 = 10: S-curve is selected with a 0.5 second operation time.

Digit 1 and 2 = 11: S-curve is selected with a 1.0 second operation time.

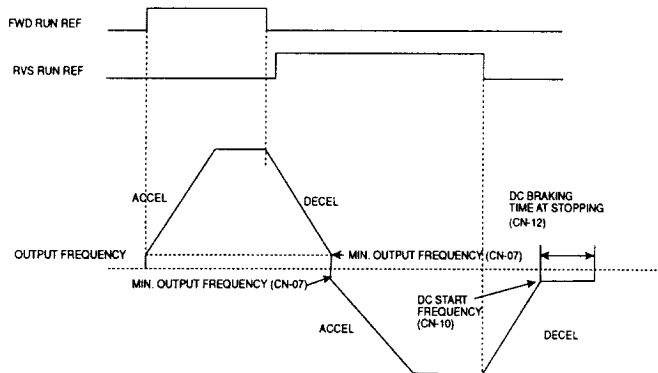
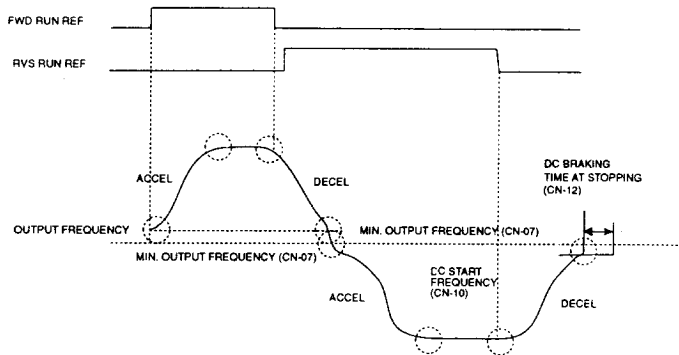

Digit 3                      Select reverse characteristics

Digit 3 = 0:                      Output frequency response to master frequency reference is as follows:  
0 to 100% for 0 to 10VDC or 4 to 20mA

Digit 3 = 1:                      Output frequency response to master frequency reference is inverted as follows: ]  
100 to 0% for 0 to 10VDC or 4 to 20mA

Digit 4                      Select operation when frequency reference is missing

Digit 4 = 0:                      Output frequency goes to zero with loss of frequency reference.

Digit 4 = 1:                      Output frequency goes to 80% of previous frequency reference or minimum output frequency whichever is greater, when current master frequency reference goes below 10% of the one that occurred 0.4 seconds before.

**5.4.1 Sn Constants Description (Continued)**

**Sn-07 : Run Mode Selection #4 (Overtorque Detection )**

Factory setting = 0000

The Overtorque Detection Circuit allows you to set a current value in %Cn-26 that if exceeded will give an alarm.

Digit 1 = 0: Overtorque Detection disable.

Digit 1 = 1: Overtorque Detection enable.

Digit 2 = 0: Overtorque Detection only during speed synchronization.

Digit 2 = 1: Overtorque Detection always except during DC injection.

Digit 3 = 0: Digital operator flashes OL3, operation continues.

Digit 3 = 1: Same as = 0, plus inverter trips, display shows OL3, and fault contacts are active.

Digit 4 = 0: Not used

**Sn-08 : Run Mode Selection #5**

Factory setting = 0000

Digit 1 = 0: Inverter recognizes frequency reference through option board (if installed).

Digit 1 = 1: Inverter recognizes frequency reference through external terminals or digital operator.  
(Also selectable through multi-function input Sn-15 through 18; set value2)

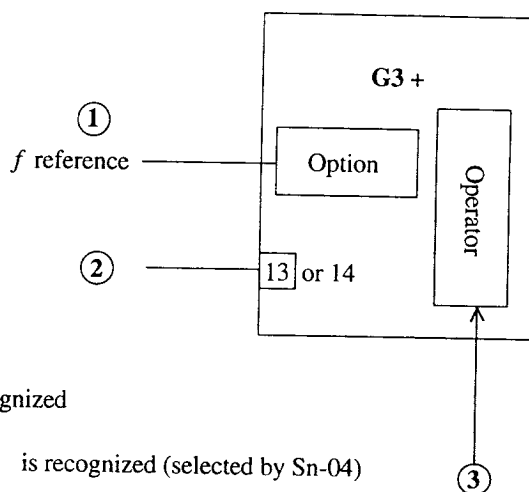

0 ⇨ ① is recognized

1 ⇨ ② or ③ is recognized (selected by Sn-04)

Digit 2 Selection run command location

Digit 2 = 0: Inverter recognizes run command through option board (if installed).

# SAFTRONICS

---

---

## 5.4.1 Sn Constants Description (Continued)

### Sn-08 : Run Mode Selection #5 (Continued)

Digit 2 = 1 : Inverter recognizes run command through external terminals or digital operator.

Digits 3 & 4 : Selection of stopping method at communication error detection by communication interface card (SI-B) per the following table.

4th	3rd	Description
0	0	Ramp to a stop by bn-02 (major fault).
0	1	Coast to stop (major fault).
1	0	Ramp to a stop by bn-04 (major fault).
1	1	Operation to continue (minor fault).

---

### Sn-09 : Analog Output Selection

Factory Setting = 0000

Digit 1 = 0: Analog output (terminals 21-22) depends on Sn-05 4th digit and Sn-09 2nd digit contents.

Digit 1 = 1: Analog output (terminals 21-22) is set by communication interface card (SI-B).

Digit 2: Selection of analog output signal (terminals 21-22) per the following table.

Sn-05 4th	Sn-09 2nd	Description
0	0	Analog output signal is proportional to inverter output frequency (Max frequency/100%).
1	0	Analog output signal is proportional to inverter output current (Rated current/100%).
0	1	Analog output signal is proportional to inverter output voltage reference (Cn-01/100%).
1	1	Analog output signal is proportional to inverter output power (Max. applicable motor capacity/100%).

Digit 3 = 0: Not Used.

Digit 4 = 0: Not Used

**Sn-10 : Protective Characteristics #1 ( Stall Prevention During Acceleration)**

Factory setting = 0000

Digit 1 = 0: Stall prevention at acceleration enabled.

Cn-28 Constant Torque Range

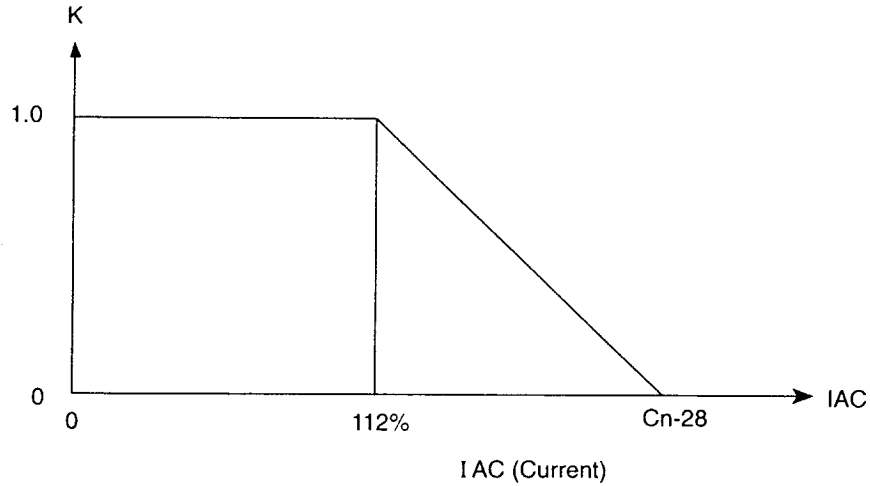

$$T \text{ actual during stall} = \frac{T \text{ acceleration}}{K}$$

Digit 1 = 1: Stall prevention at accel disabled

Cn-29 Limit of Constant HP Range

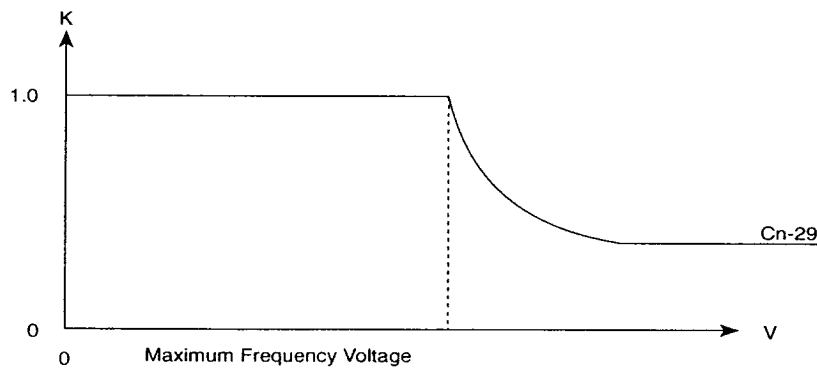

Examples: 1 = small inertia load requiring quick acceleration-machine tool or sewing machine.

**CAUTION:** Calculated acceleration torque should be less than 175%.

# SAFTRONICS

## 5.4.1 Sn Constants Description (Continued)

### Sn-10 (Continued)

Digit 2 = 0: Stall during decel enabled (Extends decel time in proportion to rise in DC bus voltage level).

Digit 2 = 1: Stall during decel disable (One example only, always turn off when using external dynamic braking resistor).

= 0: Extends decel time in proportion to rise in DC bus voltage level

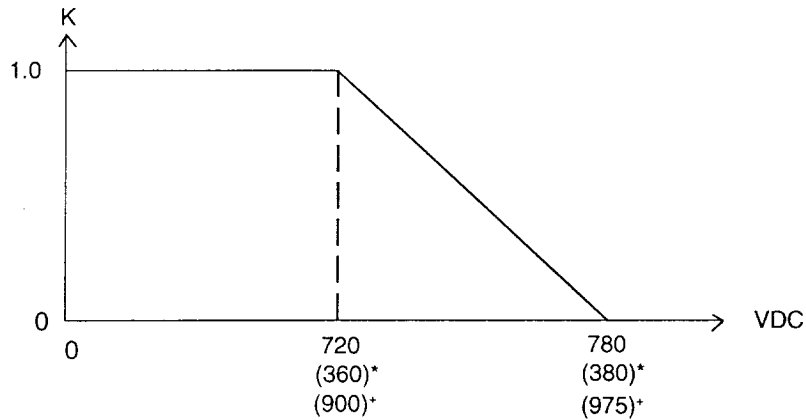

$$T \text{ actual deceleration} = \frac{T \text{ decel}}{K}$$

$$\text{i.e., at 780V, } \frac{T \text{ decel}}{0} = \text{No deceleration}$$

\* Voltage in parenthesis is for 230 volt unit.

+ Voltage in parenthesis is for 575 volt unit.

Digit 3 = 0: Stall at running enabled.

Digit 3 = 1: Stall at running disabled.

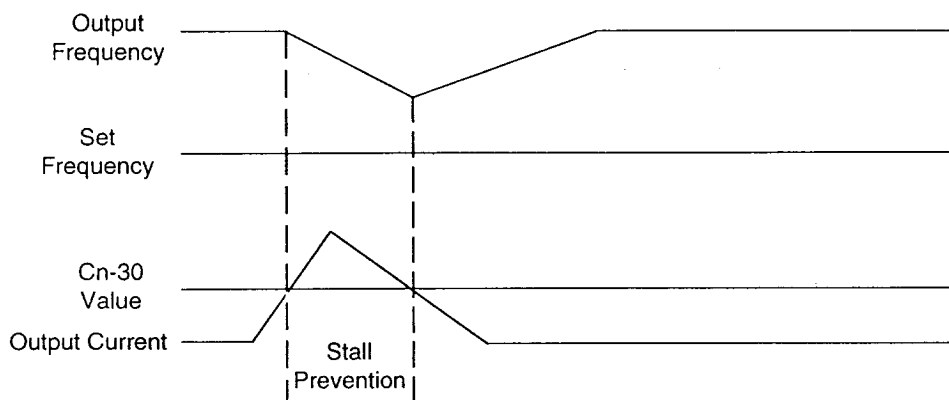

Digit 4 = 0: Stall rate is bn-02 (Deceleration time 1).

Digit 4 = 1: Stall rate is bn-04 (Deceleration time 2).

**5.4.1 Sn Constants Description (Continued)**

**Sn-11: Protective Characteristics #2**

Factory setting = 0000

Digit 1 = 0: Internal dynamic braking resistor protection is not provided.

Digit 1 = 1: Resistor protection is provided.

**NOTE:** This function is active for internal dynamic braking resistor only.

Digit 2 = 0: Fault contact is not made during auto-restart attempt.

Digit 2 = 1: Fault contact is made during auto-restart attempt.

Digit 3 = 0: Inverter is shut off when UV is detected.

Digit 3 = 1: Power-loss ride-through is enabled (time = Cn-37).

kVA/Voltage	Maximum Allowable Time	Extendable
3 k VA/230V/460V or less	1.0 seconds	Yes
Others	2.0 seconds	No

**NOTE:** During UV, terminal input changes are ignored. After restart, contacts are scanned.

**Three methods for restart:**

- (1) Allow minimum baseblock time to elapse.
- (2) Provide DB and set minimum baseblock to (Cn-40) 0.1 second and voltage recovery time (Cn-42) to 0.1 seconds (good for permanent magnet synchronous motors).
- (3) Speed search.

Digit 4 = 0: Not used.

# SAFTRONICS

---

## 5.4.1 Sn Constants Description (Continued) Sn-12 : Protective Characteristics #3

Factory setting = 0100

Digit 1 External Fault Signal State

Digit 1 = 0: NO contact (when closed, inverter responds).

Digit 1 = 1: NC contact input (when opened, inverter responds).

Digit 2 Detection of External fault Input

Digit 2 = 0: External fault signal is always detected.

Digit 2 = 1: External fault signal is detected only during operation (not detected during baseblock).

Digit 3 & 4: Stopping Method after a fault per following table.

4th	3rd	Description
0	0	Ramp to a stop by bn-02 (major fault).
0	1	Coast to stop (major fault).
1	0	Ramp to a stop by bn-04 (major fault).
1	1	Operation to continued (minor fault).

---

## Sn-13: Stopping Method Selection at Fan Fault

Factory Setting: 0100

Digit 1 = 0: Not Used

Digit 2 = 0: Not Used

Digit 3 & 4 Stopping method selection at fan fault per following table.

4th	3rd	Description
0	0	Ramp to a stop by bn-02 (major fault)
0	1	Coast to stop (major fault)
1	0	Ramp to a stop by bn-04 (major fault)
1	1	Operation to continue (minor fault)

Note: 3rd and 4th digit function is effective only for models 2030-2075, 4055-4300, and 5022-5160



**Sn-14 : Protective Characteristics (OLI) #5**

Factory setting = 0000

**Digit 1 Electronic Thermal Overload Selection**

Digit 1 = 0: Motor is protected from overload by electronic thermal.

Digit 1 = 1: Motor is not protected from overload by electronic thermal (for multi-motor applications and special motor with external blower)

**Digit 2 Overload Characteristics of Electronic Thermal**

Digit 2 = 0: Motor is protected from overload by overload characteristics of reduced torque motor (standard).

Digit 2 = 1: Motor is protected from overload by overload characteristics of constant torque motor (special motor with external blower).

**Digit 3 Time Constant of Electronic Thermal**

Digit 3 = 0: Time constant of electronic thermal is 24 minutes.

Digit 3 = 1: Time constant of electronic thermal is 5 minutes.

**Digit 4 Selection of inverter protective characteristics.**

Digit 4 = 0: When inverter output current exceeds 103%, inverter protection electronic thermal overload characteristics start operating: Inverter protection (oL2) operates at 150% for one minute to shut off inverter output.

Digit 4 = 1: When inverter output current exceeds 113%, inverter protection electronic thermal overload characteristics start operating: Inverter protection (oL2) operates at 123% for one minute to shut off inverter output.

Note: 4th digit function is effective only for Models 2030-2075, 4055-4300, and 5022-5160.

# SAFTRONICS

## 5.4.1 Sn Constants Description (Continued)

### Sn - 15 to Sn - 18 : Multi-Function Terminal Function

Factory Settings: Sn-15 = 03 Sn-16 = 04 Sn-17 = 06 Sn-18 = 08

Functions of terminal 5, 6, 7, and 8 are selected **individually** by set values of Sn-15, -16, -17, -18 respectively. Set values must be set from smaller to larger. (ie Sn-15 = 0, Sn-16 = 03 Sn-17 = 07, Sn-18 = 09)

Set Value	Function	Description
00	Fwd/Rev selection	3-wire control mode (00 set to Sn-15): Terminal -1: operation, -2: stop, -5: fwd/rev select
01	Operation signal selection (local / remote)	Open: Operates according to Sn-04 1st and 2 digits (remote). Closed: Operates by operation or frequency reference from the digital operator.
02	Option/inverter changeover	Master/auxiliary speed changeover
03	Multi-step speed reference 1	See Table Page 45.
04	Multi-step speed reference 2	See Table Page 45.
05	Multi-step speed reference 3	See Table Page 45.
06	Jogging frequency selection	Closed: Jogging frequency select
07	Accel/decel time changeover	Open: Accelerates/decelerates by bn-01, bn-02. Closed: Accelerates/decelerates by bn-03, bn-04
08	External BB of NO contact	Closed: Shuts off inverter output only (frequency reference is held).
09	External BB of NC contact	Open: Shuts off inverter output only (frequency reference is held).
0A	Accel/Decel speed prohibit (HOLD Command)	Closed: Frequency reference is held. (SFS operation is stopped)
0B	Inverter overheat prediction	Closed: OH2 blinks on digital operator
0C	Multi-function analog input effective	Closed: Analog input (terminal 16) effective Open: Analog input (terminal 16) ineffective
10	UP Command	Closed: Output frequency increment.
11	DOWN Command	Closed: Output frequency decrement
12	FJOG Command	Closed: Forward jog run. FWD LED lights
13	RJOG Command	Closed: Reverse jog run. REV LED does not light

**5.4.1 Sn Constants Description (Continued)  
Sn-15 to 18 (Continued)**

Set Value	Function	Description
14 to 1F	Not used	—
20 to 2F	External fault 1*	See Table below.
30 to 3F	External fault 2*	See Table below.
40 to 4F	External fault 3*	See Table below.
50 to 5F	External fault 4*	See Table below.
60	DB reference (operation JOG with priority)	Closed : DB action when less than DB start frequency and DB reference is closed
61	Speed Search 1	Closed : Speed search operation from maximum frequency
62	Speed Search 2	Closed : Speed search operation from set frequency
63	Energy-saving operation	Closed : Energy saving
64 to 6F	Not used	—

\*: For the first digit of external faults 1 to 4, the following 4 bits are set after being converted to hexadecimal.

Bit Number	0	1
0	External fault: NO contact input	External fault: NC contact input
1	External fault: always detected	External fault: detected during operation
3,2	Process to be selected when external fault is detected	00: Deceleration to stop (major failure) 01: Coasting to stop (major failure) 10: Deceleration to stop at bn-04 (TDEC2) (major failure) 11: Operation to be continued (minor failure)

**NOTE:** Sn-15 through Sn-18 set values must be in ascending order. If not, OPE3 error will be displayed.

# SAFTRONICS

## 5.4.1 Sn Constants Description (Continued) Sn-15 through 18 (Continued)

Forward/Reverse (Set value = 00)

Setting value 00 enables 3-wire control

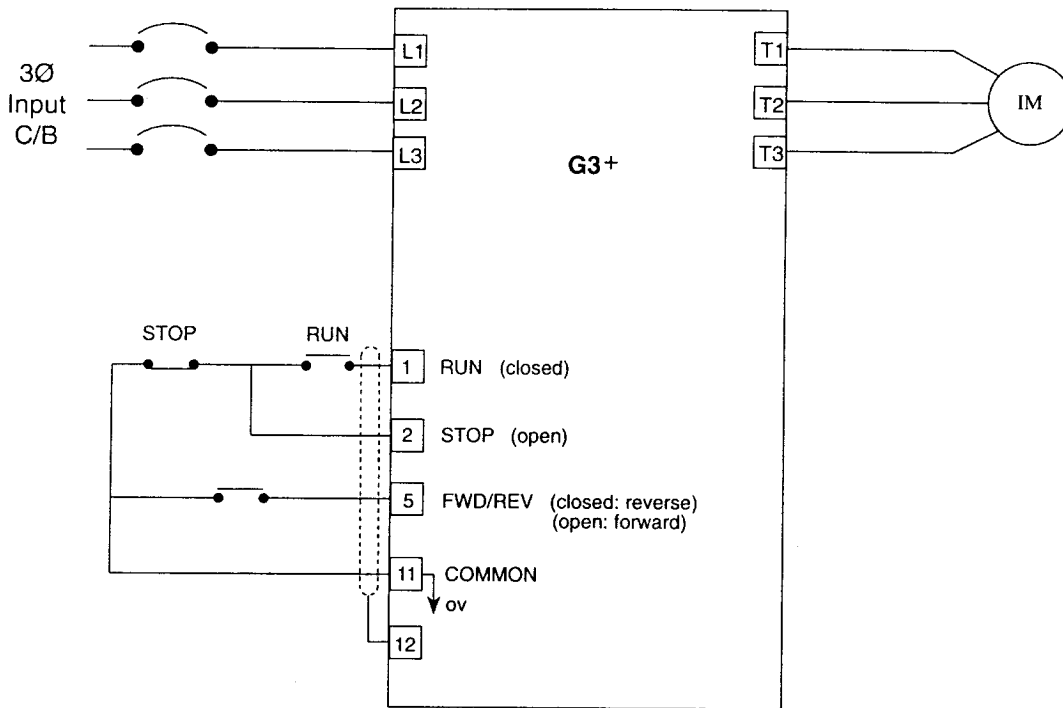

**Three wire control**

**5.4.1 Sn Constants Description (Continued)  
Sn-15 through 18 (Continued)**

Operation Signal (set value 01)

Open: Controlled by Sn-04 setting  
Closed: Controlled by digital operator

CAN BE USED AS LOCAL / REMOTE

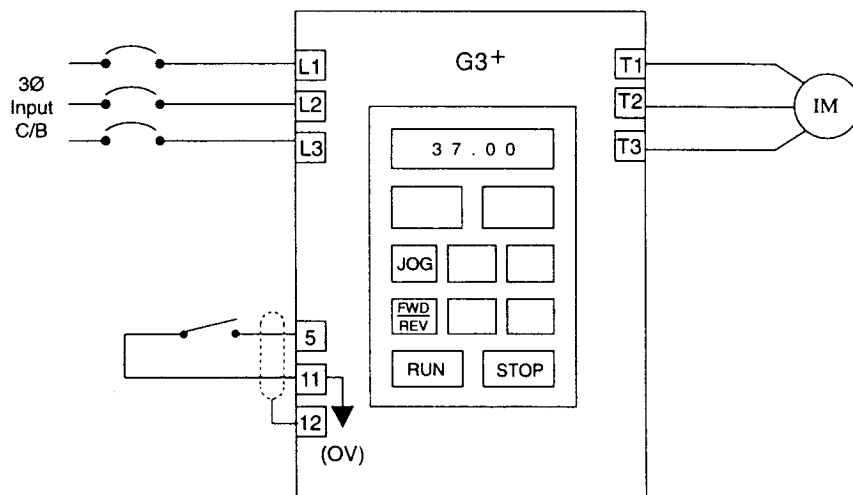
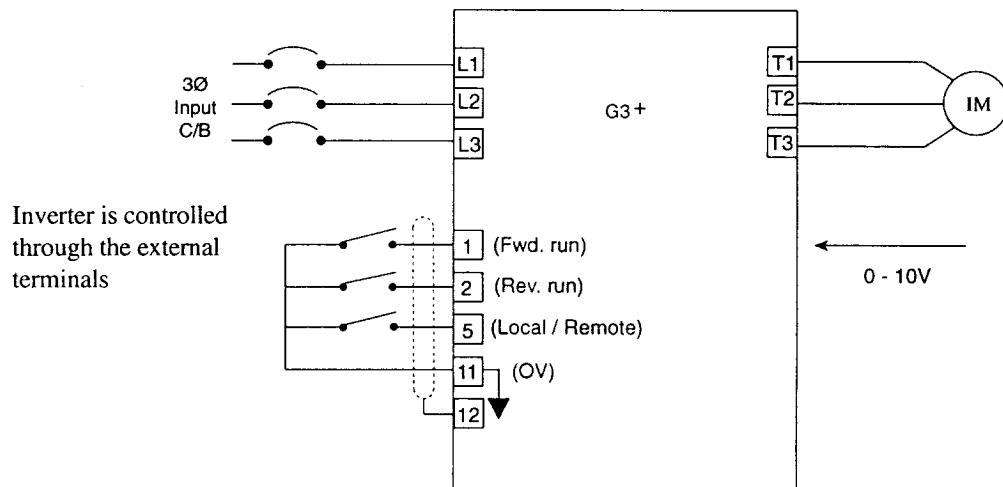

# SAFTRONICS

## 5.4.1 Sn Constants Description (Continued) Sn-15 through 18 (Continued)

Option / Inverter Changeover (Set value = 02)

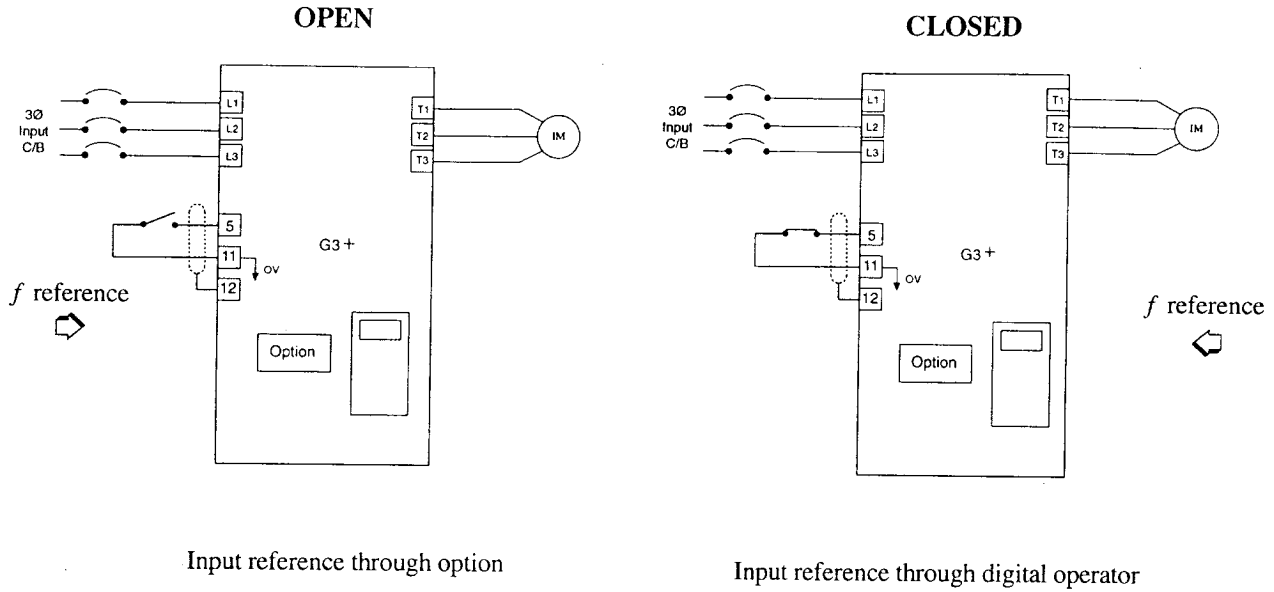

### Multi-Step Speed Inputs (Set value = 03 to 06)

Select Combination (X: open, O: closed, -: no effect)

Jogging Frequency Reference	Multi-step Speed Reference 3	Multi-step Speed Reference 2	Multi-step Speed Reference 1	Frequency Reference
X	X	X	X	Frequency Reference 1 (An-01) Main speed frequency reference *1
X	X	X	O	Frequency Reference 2 (An-02) Main speed frequency reference *2
X	X	O	X	Frequency Reference 3 (An-03)
X	X	O	O	Frequency Reference 4 (An-04)
X	O	X	X	Frequency Reference 5 (An-05)
X	O	X	O	Frequency Reference 6 (An-06)
X	O	O	X	Frequency Reference 7 (An-07)
X	O	O	O	Frequency Reference 8 (An-08)
O	-	-	-	Jogging speed reference (An-09)

\*1: An-01 effective when Sn-04, 1st Digit is set to 1.

\*2: Effective only when Sn-19 is **not** set to 00.

**5.4.1 Sn Constants Description (Continued)**  
**Sn-15 through 18 (Continued)**

Accel / Decel Time Changeover (Set value = 07)

Open: Accel/decel time from bn-01 and bn-02.

Closed: Accel/decel time from bn-03 and bn-04.

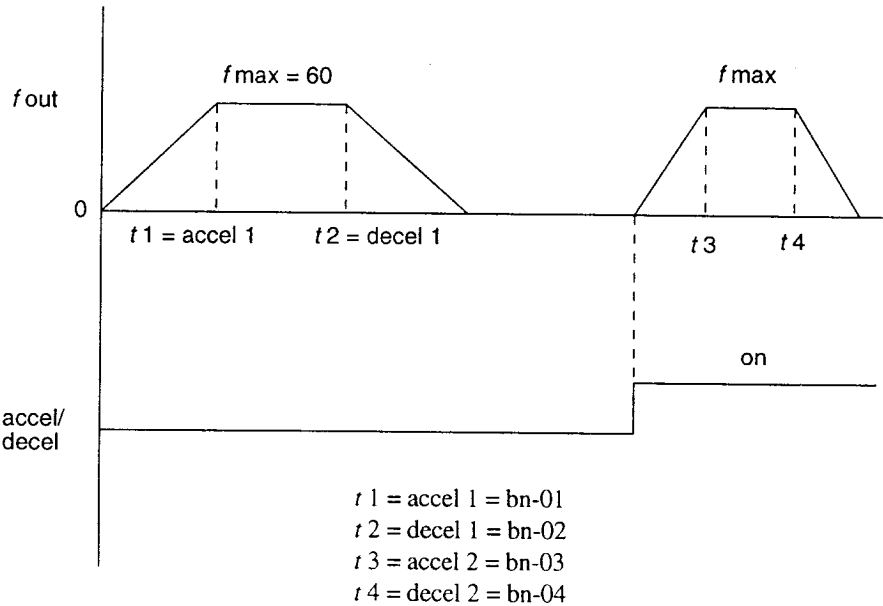
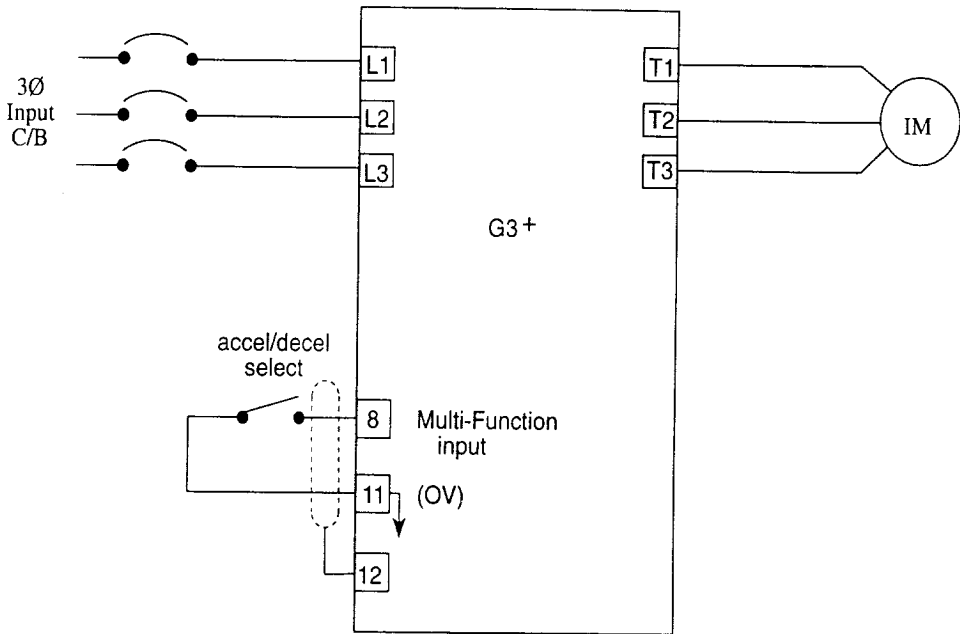

# SAFTRONICS

## 5.4.1 Sn Constants Description (Continued) Sn-15 through 18 (Continued)

External Base Block (Set value = 08)

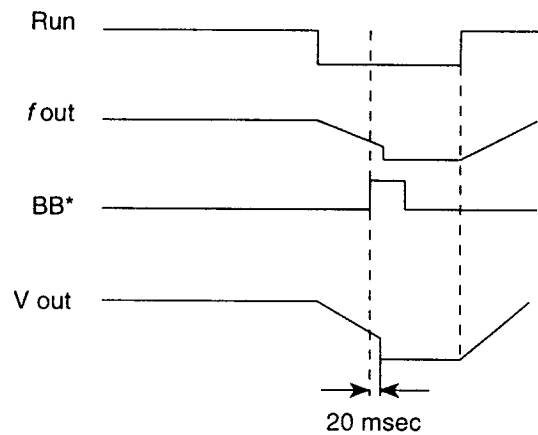
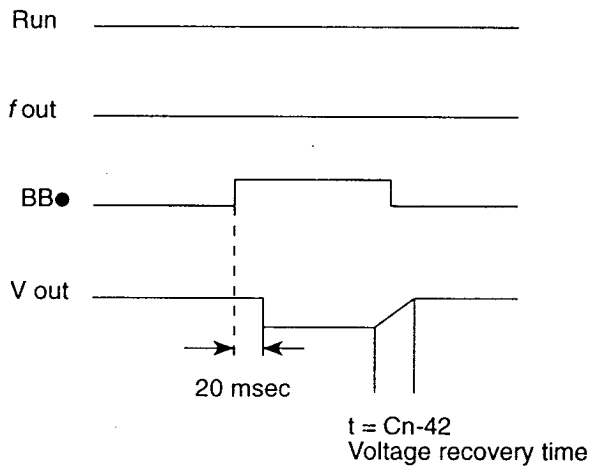
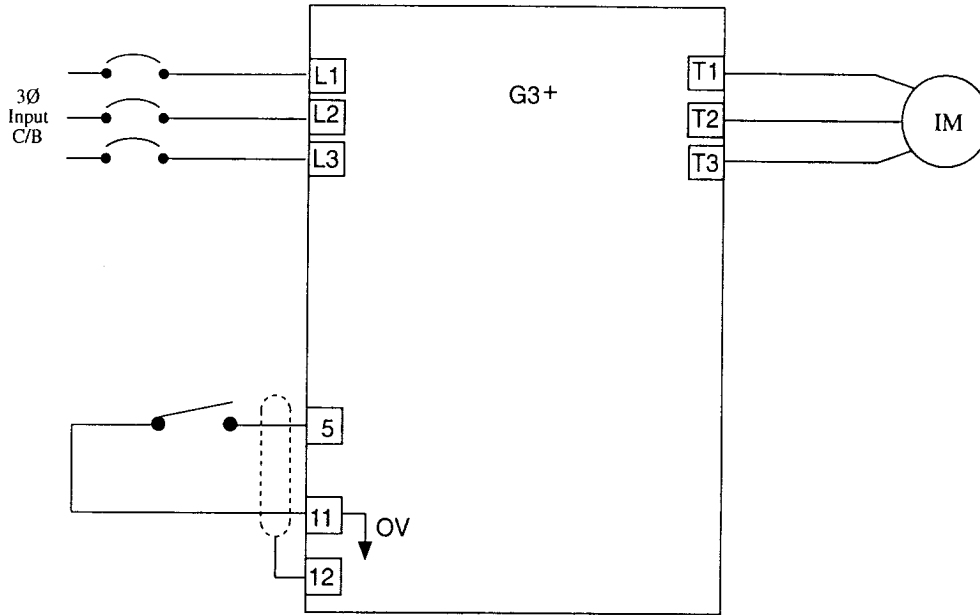

- Base block is momentary if input while running.
- \* Base block latches if input after stop input.

External Base Block (Set value = 09)  
Same as above except by opening contact.





# SAFTRONICS

---

## 5.4.1 Sn Constants Description (Continued) Sn-15 through 18 (Continued)

### Major Failure

- (a) Fault contact output relay is output immediately.
- (b) Reset is enabled in baseblock status.
- (c) Priority of more than one external faults input:  
Coasting to stop → Emergency deceleration to stop → Deceleration to stop
- (d) Retry operation at fault is ineffective when an external fault is input.

### Minor Failure

- (a) Fault display blinks only when an external fault is input (displayed for 0.5 seconds if less than 0.5 seconds).

### Example:

External faults 1 to 4 set in multi-function terminal numbers 5 to 8.

Fault Number	Multi-Function Terminal	Digital Operator Display (Major Fault)	Digital Operator Display (Minor Fault)
External Fault 1	Terminal 5	EF5-LIT (HOLD)	EF5 Blinks
External Fault 2	Terminal 6	EF6-LIT (HOLD)	EF6 Blinks
External Fault 3	Terminal 7	EF7-LIT (HOLD)	EF7 Blinks
External Fault 4	Terminal 8	EF9-LIT (HOLD)	EF8 Blinks

**5.4.1 Sn Constants Description (Continued)  
Sn-15 through 18 (Continued)**

DC Braking Reference (Set value = 60)

Allows external control of DC injection function

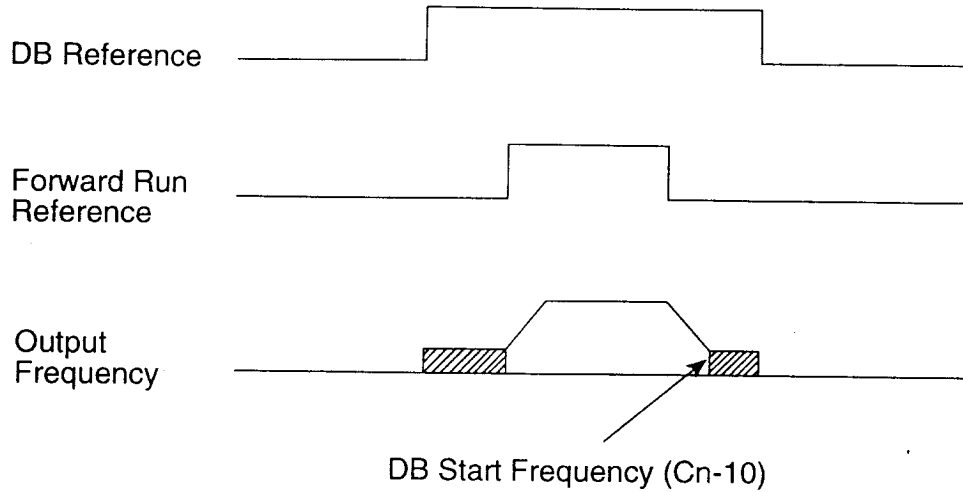

Speed Search Starting Frequency (Set value = 61, 62)

- A. Set Value = 61: Speed search is from maximum frequency.
- B. Set Value = 62: Speed search is from set frequency.

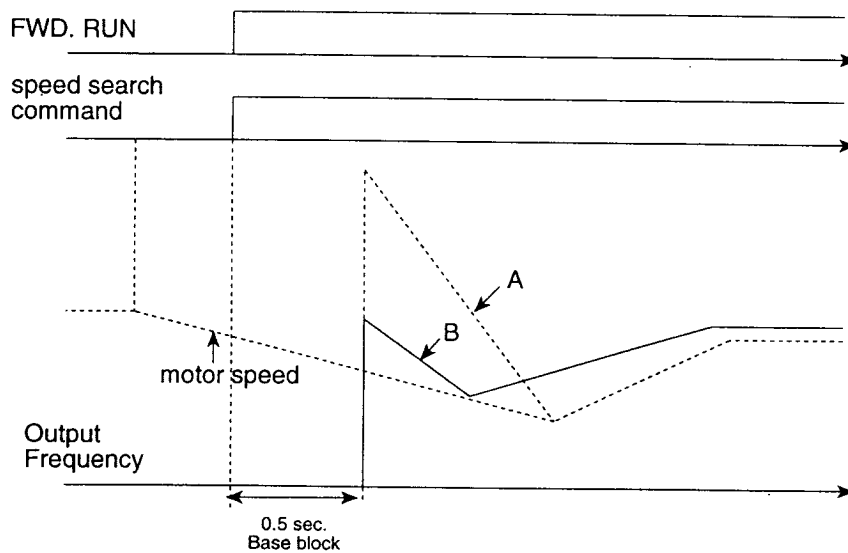

- (1) Speed search after momentary power loss is from present frequency. After completion of search, unit will follow input reference.
- (2) Run command must follow the speed search command.

## 5.4.1 Sn Constants Description (Continued) Sn-15 through 18 (Continued)

Energy Saving Operation (Set value = 63)

Reduces output voltage by value in bn-09 when closed.

Energy Saving Operation Set value = 63

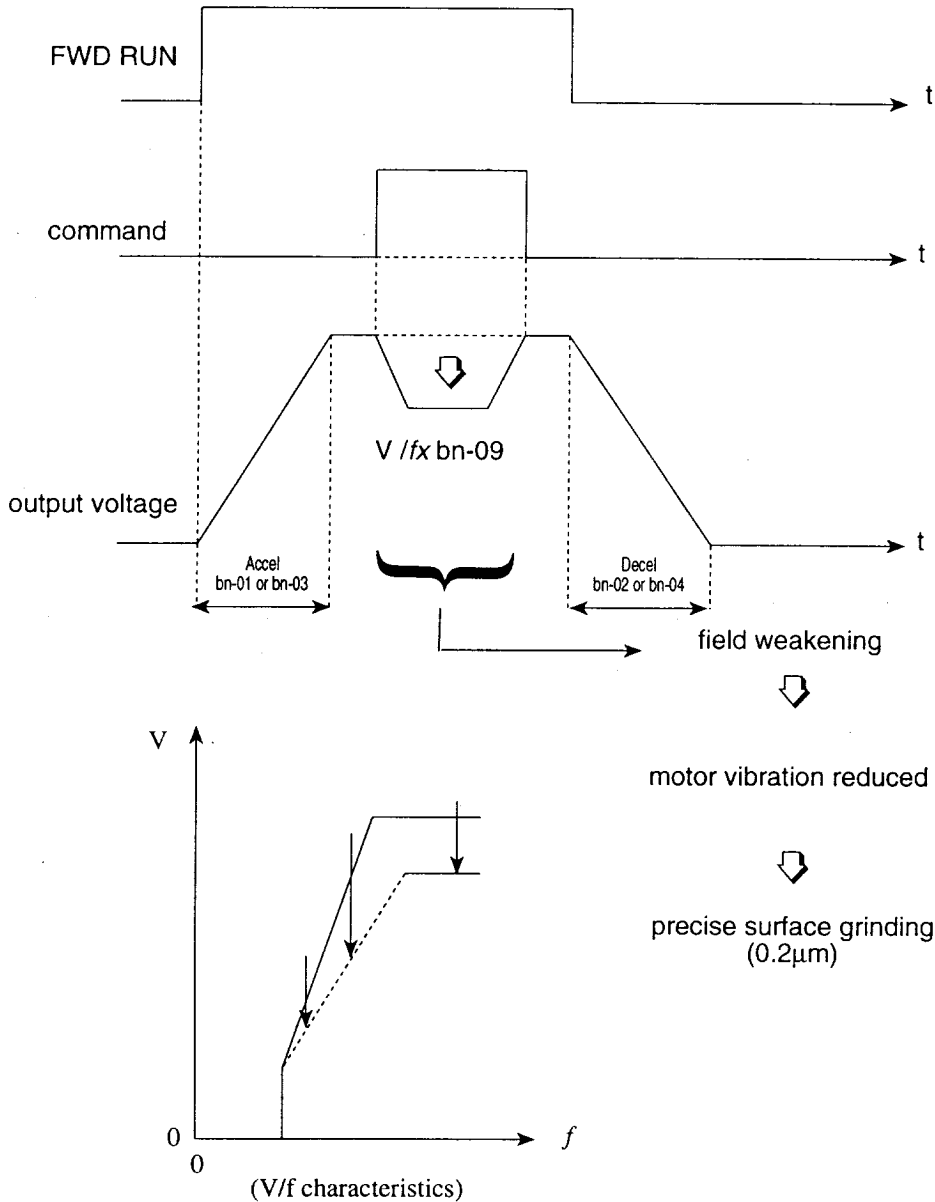

**Purpose:** In some grinding applications, vibration can be reduced by reducing the output voltage. However, during acceleration and deceleration, full torque, and therefore full voltage is required. By using the energy saving function, voltage will be reduced only when the contact is closed.

**5.4.1 Sn Constants Description (Continued)**

**Sn-19 : Multi-Function Analog Input**

Factory setting = 00

Selects function to be controlled by analog input to terminal 16.

Set Value	Function	Description
00	Auxiliary frequency ref*	Used for multi-step speed operation
01	FGAIN	Total gain = internal gain (bn-05) x FGAIN
02	FBIAS1	Total bias = internal bias (bn-06) + FBIAS1
03	FBIAS2 (+/-)	Total bias = internal bias (bn-06) + FBIAS2
04	Overtorque detection level	Internal overtorque detection level (Cn-26) ineffective
05	VBIAS †	VBIAS is added after V/f conversion.
06	Accel/decel time shortening time	Accel/decel time is variable by analog input
07	DC braking current	DC braking current is variable by analog input (10V/ inverter rated current), Cn-11 ineffective.
08	Stall level during running	Stall level during running is set by analog input. Cn-30 ineffective.
09	Frequency reference lower limit	Frequency reference lower limit is set by analog input. Larger setting of Cn-15 or analog input becomes effective.
0A	Setting prohibit frequency 4	Setting prohibit frequency No. 4 in addition to Cn-16~Cn-18.
0B-0F	Not used	

\* Not to be used with An-02.

† VBIAS = 0 to 200V for 460V series.

VBIAS = 0 to 287.5V for 575V series.

# SAFTRONICS

## 5.4.1 Sn Constants Description (Continued) Sn-19: Multi-Function Analog Input (Continued)

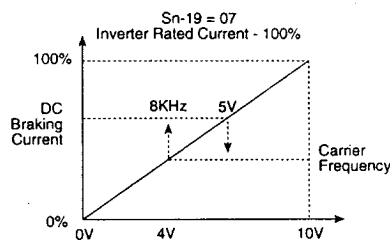
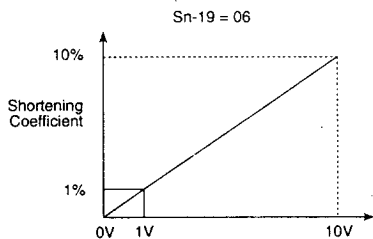
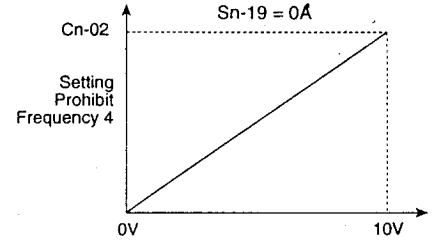
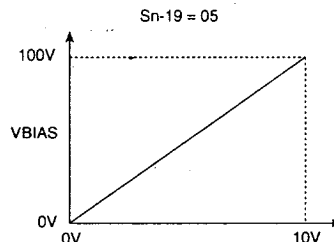
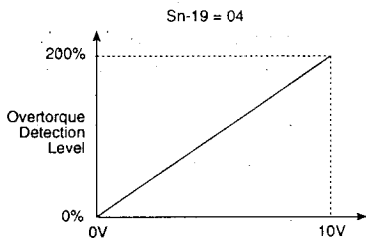
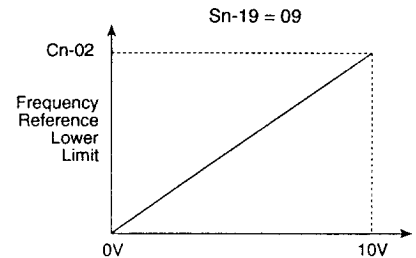
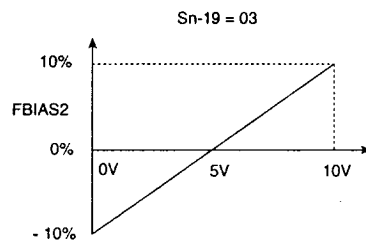
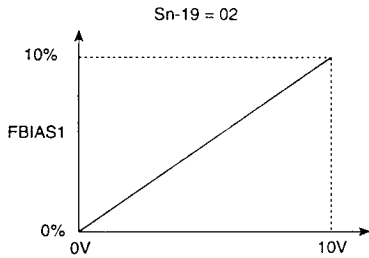
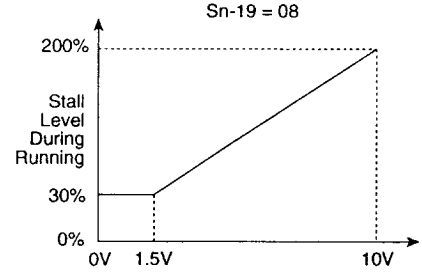
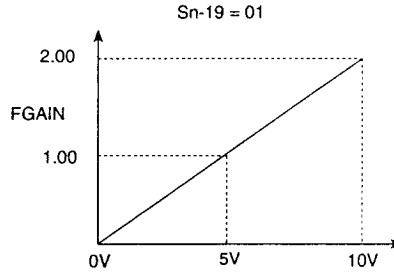
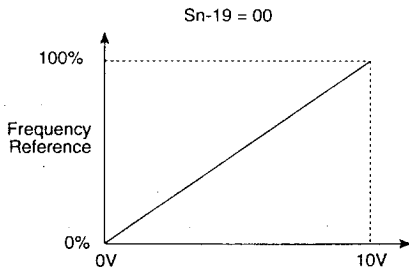

Actual accel/decel time is as follows:

$$\text{Actual Accel/decel Time} = \frac{\text{Accel/decel Time (bn-01 to 04)}}{\text{Shortening Coefficient}}$$

**5.4.1 Sn Constants Description (Continued)**

**Sn-20 to 22 : Multi-Function Contact Output Function Selection**

Factory settings: Sn-20 = 00    Sn-21 = 01    Sn-22 = 02

Functions of output terminals 9 and 10 (dry contact), external terminal 25 (open collector), and external terminal 26 (open collector), can be set independently by Sn-20, Sn-21, and Sn-22 respectively.

Contact is output after a signal has been detected for 0.1 second minimum

Set Value	Description	
	Name	Signal Level (Closed)
00	Output during operation	Close: During operation
01	0 speed	Close: 0 speed
02	Frequency (speed) Synchronization	Close: $(\text{Frequency reference} - \text{Cn-22}) \leq \text{output reference} \leq (\text{frequency reference} + \text{Cn-22})$
03	Desired frequency (speed) synchronization	Close: Set value 2 speed synchronization and; $(\text{Cn-21} - \text{Cn-22}) \leq \text{output frequency} \leq (\text{Cn-21} + \text{Cn-22})$
04	Frequency (speed) detection	Close: Output frequency $\leq$ Cn-21
05	Frequency (speed) detection	Close: Output frequency $\geq$ Cn-21
06	Inverter operation ready	Close: Inverter operation ready
07	During UV	Close: Momentary power loss status being detected
08	During BB	Close: Inverter baseblock
09	Frequency reference mode	Open: Operation by frequency reference from external terminal Close: Operation by frequency reference from operator
0A	Operation reference mode	Open: Operation by run command from external terminal Close: Operation by run command from operator
0B	Overtorque detection	Close: Overtorque detection
0C	FREF missing	Close: FREF missing
0D	Braking resistor fault	Close: Braking resistor overheating or braking transistor fault
0E	Major failure (FAULT)	Close: Fault (excluding CPF00, CPF01)
0F	Not used	

# SAFTRONICS

## 5.4.1 Sn Constants Description (Continued)

### Sn-20 to 22 : Multi-Function Contact Output Function Selection (Continued)

Contact During Operation (Set value = 00)

Closed when FWD or REV run command is input or when the inverter is outputting the voltage.

0 Speed Contact (Set value = 01)

Closed when the inverter output frequency is less than the minimum frequency (Cn-07).

Frequency (Speed) Synchronization (Set value = 02)

Closed when the output frequency is within the detection width (Cn-22) as shown below.

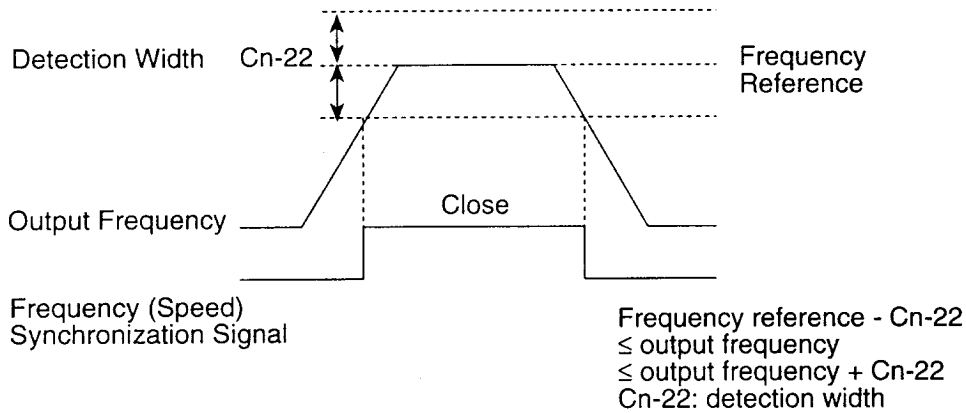

Desired Frequency (Speed) Synchronization (Set value = 03)

Closed when the output frequency is within the detection width (Cn-22) as shown below.

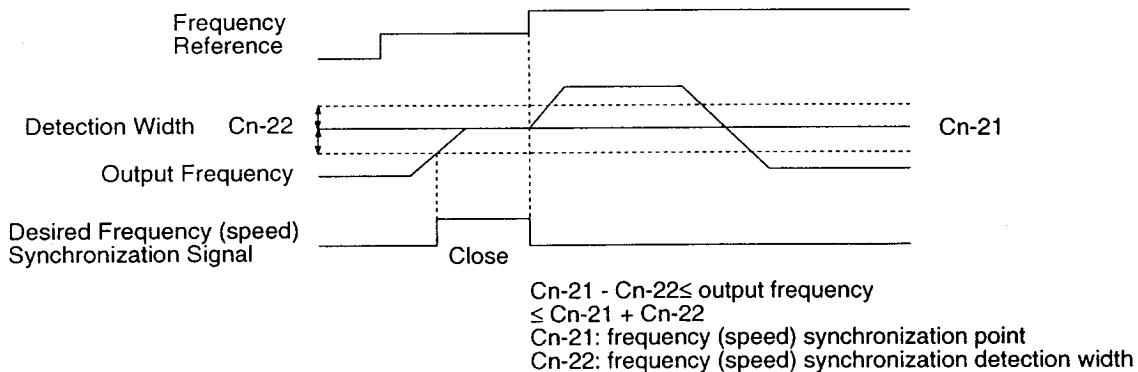



**5.4.1 Sn Constants Description (Continued)**

**Sn-20 to 22 Multi-Function Contact Output Function Selection (Continued)**

Frequency Detection Contact (Set Value = 04)

Closed when the output frequency is less than Cn-21 as shown below.

- Output frequency  $\leq$  Cn-21
- Cn-21 frequency (speed) synchronization point.
- Cn-22: frequency (speed) synchronization detection width.

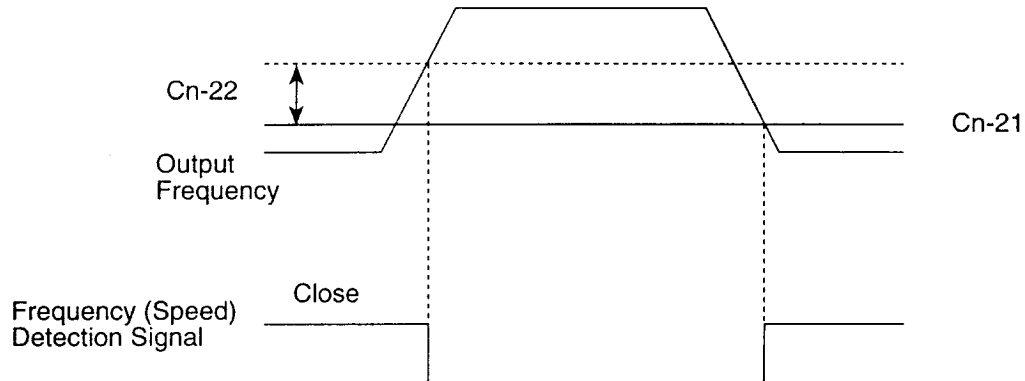

Frequency Detection Contact (Set Value = 05)

Closed when the output frequency is more than Cn-21 as shown below.

- Output frequency  $\geq$  Cn-21
- Cn-21: frequency (speed) synchronization point.
- Cn-22: frequency (speed) synchronization detection width.

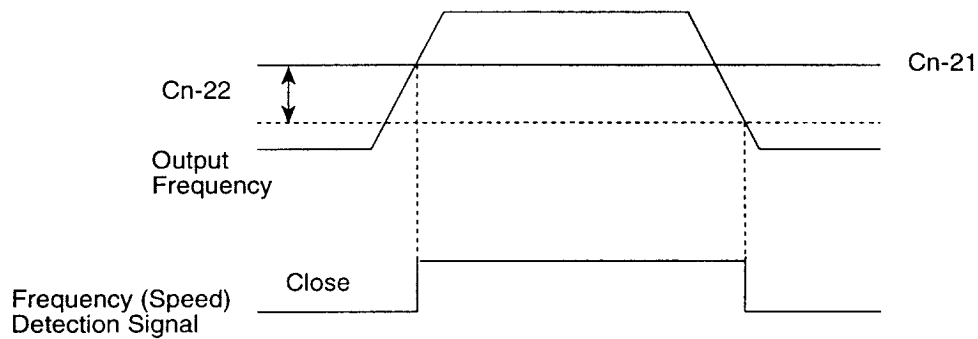

Inverter Operation Ready (Set Value = 06)

Closed when inverter is ready for operation.

# SAFTRONICS

---

---

## 5.4.1 Sn Constants Description (Continued)

### Sn-20 to 22 Multi-Function Contact Output Function Selection (Continued)

Contact During UV (Set Value = 07)

Closed while the inverter is detecting undervoltage.

---

Contact During BB (Set Value = 08)

Closed while the inverter output is shut off.

---

Frequency Reference Mode Contact (Set Value = 09)

Closed when frequency reference is from the operator.

---

Run Reference Mode Contact (Set Value = 0A)

Closed when run reference is selected from the operator.

---

Overtorque Detection Contact (Set Value = 0B)

Closed while the inverter is detecting overtorque. Overtorque detection level is set by Cn-26 and overtorque detection time is set by Cn-27.

---

Frequency Reference is Missing (Set Value = 0C)

Closed when frequency reference is lost.

---

Braking Resistor Fault (Set Value = 0D)

Closed during braking resistor overheating or when braking transistor fault is detected.

---

Fault Contact (Set Value = 0E)

Closed when the inverter detects a major failure. However, watchdog (CPF00) and transmission error (CPF01) between inverter and operator cannot be detected.

---

**Sn-23 : Not Used**

---

**Sn-24 : Not Used**

---

### Sn-25 : Bi-polar Analog Input Selection

Factory setting = 0000

Selects frequency reference setting by 14 bit bi-polar analog option (AI-14B).

Digit 1 = 0: The motor rotating direction is as follows depending on the combination of additional sign and FWD/REV run signals.

Digit 1 = 1: When additional sign is minus (-), the frequency reference is 0Hz (stop). The motor rotating direction is determined by FWD/REV signals only.

**5.4.1 Sn Constants Description (Continued)**

**Sn-25 : Bi-polar Analog Input Selection (Continued)**

Sign of Input Signal	Run Signal	Motor Rotating Direction when 1st Digit = 0	Motor Rotating Direction when 1st Digit = 1
Plus (+)	FWD run signal	Forward	Forward
Plus (+)	REV run signal	Reverse	Reverse
Minus (-)	FWD run signal	Reverse	0Hz (stop)
Minus (-)	REV run signal	Forward	0Hz (stop)

Digit 2 = 0: Not Used

Digit 3 = 0: Not Used

Digit 4 = 0: Not Used

**Sn-26 : Digital Input Selection**

Factory setting = 0000

Selects frequency reference setting mode of digital input option (DI-08). By selecting binary, 100% level of option card is automatically selected. Effective when Cn-20 = 0 or 1.

Set Value	Frequency Reference Setting Mode
0000	BCD Setting unit 1 %
0001	BCD Setting unit 0.1%
0010	BCD Setting unit 0.01%
0011	BCD Setting unit 1Hz
0100	BCD Setting unit 0.1Hz
0101	BCD Setting unit 0.01Hz
0111	Binary Di-8 : 100% /255
1000	Binary Effective in monitor mode

## 5.4.1 Sn Constants Description (Continued)

### Sn-27 : Pulse Output Selection

Factory setting = 0010

Digit 1: Digital output card DO-08

Digit 1 = 0: DO-08 output signal combination 1 (output data fixed)

Digit 1 = 1: DO-08 output signal combination 2 (encoded output)

Digits 2 to 4: Selects the number of pulse monitor option output pulses.

4th	3rd	2nd	
0	0	0	Number of inverter output pulses X1 (Synchronized with output frequency)
0	0	1	Number of inverter output pulses X6
0	1	0	Number of inverter output pulses X10
0	1	1	Number of inverter output pulses X12
1	0	0	Number of inverter output pulses X36

### Sn-28 : Analog Output Selection

Factory setting = 0100

Selects analog output (A0-08 and A0-12) option output signals for each channel. Output signal gain is adjusted by bn-11 or bn-12.

CH-1	1st Digit 2nd Digit	00 : Output frequency (max. frequency / 100%) 01 : Output current (rated current / 100%) 10 : Output voltage reference (input voltage / 100%) 11 : DC voltage (400V / 100%)*	100% level to be adjusted by bn-11
CH-2	3rd Digit 4th Digit	00 : Output frequency (max. frequency / 100%) 01 : Output current (rated current / 100%) 10 : Output voltage reference (input voltage / 100%) 11 : DC voltage (400V / 100%)*	100% level to be adjusted by bn-12

\*DC voltage level shown is for 230V series. For 460V series x 2. For 575V series x 2.5.

**5.5 Control Constant Cn-**

Cn- <input type="text"/> <input type="text"/>	Data Name	Set Unit	Set Range	Factory Setting
01	Input voltage	0.1 V	0.0 - 255.0 (230V) 0.0 - 510.0 (460V) 0.0 - 733.1 (575V)	230.0 460.0 575.0
02	Max. frequency	0.1 Hz	50.0 - 400.0	*2
03	Max. voltage	0.1 V	0.0 - 255.0 (230V) 0.0 - 510.0 (460V) 0.0 - 733.1 (575V)	*2
04	Max. voltage frequency	0.1 Hz	0.0 - 400.0	*2
05	Mid. output frequency	0.1 Hz	0.0 - 400.0	*2
06	Mid. output frequency voltage	0.1 V	0.0 - 255.0 (230V) 0.0 - 510.0 (460V) 0.0 - 733.1 (575V)	*2
07	Min. output frequency	0.1 Hz	0.0 - 400.0	*2
08	Min. output frequency voltage	0.1 V	0.0 - 255.0 (230V) 0.0 - 510.0 (460V) 0.0 - 733.1 (575V)	*2
09	Motor rated current	0.1 A	*4	*1 *7
10	DC braking start frequency	0.1 Hz	0.0 - 10.0	01.5
11	DC braking current	1 %	0 - 100 *6	050
12	DC braking time at stopping	0.1 sec	0.0 - 25.5	00.5
13	DC braking time at starting	0.1 sec	0.0 - 25.5	00.0
14	Frequency (speed) reference upper limit	1%	0 - 109	100
15	Frequency (speed) reference lower limit	1 %	0 - 109	000
16	Setting prohibit of frequency No. 1	0.1 Hz	0.0 - 400.0	000.0
17	Setting prohibit of frequency No. 2	0.1 Hz	0.0 - 400.0	000.0
18	Setting prohibit of frequency No 3	0.1 Hz	0.0 - 400.0	000.0
19	Setting prohibit frequency band width	0.1 Hz	0.0 - 25.5	01.0
20	Operator display mode	1	0 - 39999	00000
21	Speed agree set point	0.1 Hz	0.0 - 400.0	000.0
22	Speed agree band width	0.1 Hz	0.0 - 25.5	02.0
23	Carrier frequency upper limit	0.1 k Hz	0.4 - 15.0	*3
24	Carrier frequency lower limit	0.1 k Hz	0.4 - 15.0	*3
25	Carrier frequency proportional gain	1	0 - 99	*3

# SAFTRONICS

## 5.5 Control Constant Cn- (Continued)

26	Overtorque detection level	1 %	30 - 200	160
27	Overtorque detection time	0.1 sec	0.0 - 25.5	00.1
28	Stall prevention level during acceleration (Constant Torque)	1%	30 - 200	170
29	Stall prevention level during acceleration (Constant HP)	1 %	30 - 200	050
30	Stall prevention level during running	1%	30 - 200	160
31	Motor cable to cable resistance	0.001Ω	0.000 - 65.535	*1
32	Iron loss	1W	0 - 65535	*1
33	Torque compensation limiter	1V	0 - 50 (230V) 0 - 100 (460V) 0 - 143 (575V)	*1
34	Motor no-load current	1 %	0 -99 *5	30
35	Slip compensation delay time	0.1 sec	0.0 - 25.5	00.0
36	No of auto restart attempts	1	0 - 10	00
37	Power loss ride-through time	0.1 sec	0.0 - 2.0	*1
38	Speed search operation level	1 %	0 - 200	150
39	Speed search decel time	0.1 sec	0.0 - 25.5 *8	02.0
40	Min. baseblock time	0.1 sec	0.0 - 2.0	*1
41	V/f during speed search	1%	0 - 100	100
42	Voltage recovery time	0.1 sec	0.1 -2.0	0.3

\*1 Factory setting differs depending on inverter capacity (Sn-01 set value).

\*2 Initial value differs depending on V/f (Sn-02 set value).

\*3 Factory setting differs depending on main circuit element (IGBT rating).

\*4 Set in a range of 10 to 200% of inverter rated current.

\*5 Motor rated current (Cn-09) is set as 100% level.

\*6 Set value ≤ 50% : carrier frequency = 8kHz.  
Set value > 50% : carrier frequency = 1kHz.

\*7 For initial value of motor rated current (Cn-09), refer to the table in page 61.

\*8 If set to zero, speed search will be disabled.

**5.5.1 Cn Constants Description**

**Cn-01 : Input Voltage**

Factory settings: 230 volt series = 230.0    460 volt series = 460.0    575 volt series = 575.0

1) Input Voltage

Setting Range: 0-255V/0-510V/0-733.1

Setting Increments: 0.1V

With standard V/f pattern (Sn-02 = 0~F)

Selects

1) Over Voltage and Dynamic braking default values

Inverter Voltage (Cn-01)		OV Level		BTR Level		UV Level	
Inverter (Class)	Set Value	Detection	Return	On	OFF	Detection	Return
230V	255 or less	400	380	380	375	210	220
460V	≥400	800	760	760	750	420	440
	<400	700	660	660	650	420	440
575V	≥500	1000	950	950	938	525	550
	>500	875	825	825	812	525	550

2) Output Voltage

Example:

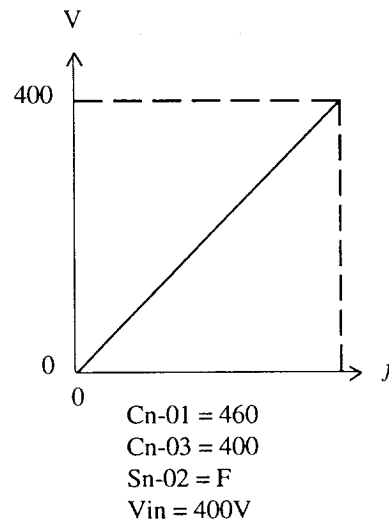
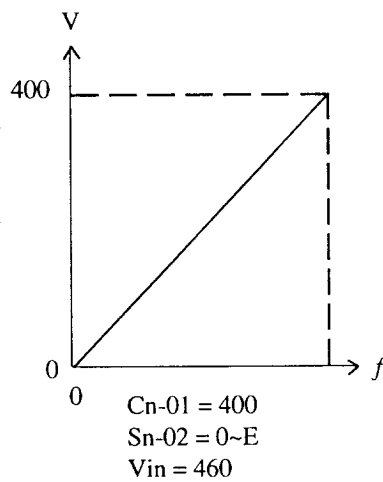

## 5.5.1 Cn Constants Description (Continued)

### Cn-02 through Cn-08

Factory settings: Cn - 02 = 060.0  
Cn - 03 = 230.0  
Cn - 04 = 060.0  
Cn - 05 = 003.0  
Cn - 06 = 017.2  
Cn - 07 = 001.5  
Cn - 08 = 011.5

For Customized V/f pattern

Frequency Setting Range: 0 to 400.0 Hz  
Frequency Setting Increment: 0.1 Hz  
Voltage Setting Range: 0 - 255V /0-510V/0-733.1  
Voltage Setting Increment: 0.1 V

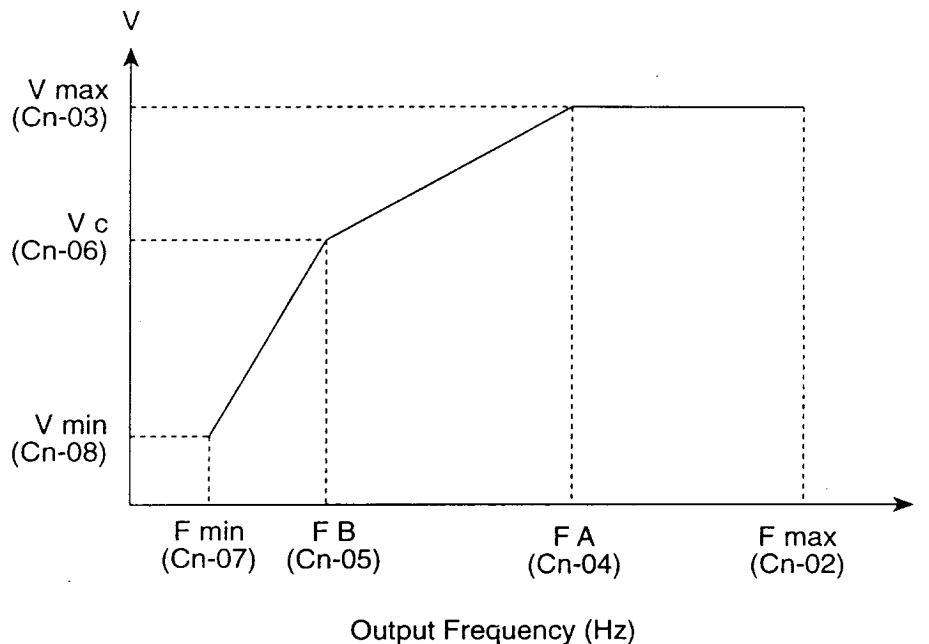

- Note: 1. Adjustment available only if Sn-02, Data "0F".  
2. Double voltages shown for 460 Volt Series Inverter.  
3. For 575 Volt Series Inverter, multiply voltages shown by 2.5.



**5.5.1 Cn Constants Description (Continued)**  
**Cn-09 Motor Rated Current**

**230 Volt Series Inverter**

<u>Model #</u>	<u>Sn-01 Data</u>	<u>Cn-09 Data</u>
20P4	00	01.9
20P7	01	03.3
21P5	02	06.1
22P2	03	08.5
23P7	04	14.1
25P5	05	20.7
27P5	06	27.5
2011	07	39.7
2015	08	53.0
2018	09	65.8
2022	0A	77.2
2030	0B	105.0
2037	0C	131.0
2045	0D	156.0
2055	0E	190.0
2075	0F	224.0

**460 Volt Series Inverter**

<u>Model#</u>	<u>Sn-01 Data</u>	<u>Cn-09 Data</u>
40P4	20	01.1
40P7	21	01.7
41P5	22	03.1
42P2	23	04.2
43P7	24	06.8
45P5	25	10.2
47P5	26	13.4
4011	27	20.1
4015	28	26.7
4018	29	33.4
4022	2A	38.5
4030	2B	52.5
4037	2C	65.5
4045	2D	78.0
4L45	3F	78.0
4055	2E	98.0
4075	2F	120.0
4110	31	175.0
4160	33	245.0
4185	34	306.0
4220	35	368.0
4300	36	490.0

**575 Volt Series Inverter**

<u>Model #</u>	<u>Sn-01 Data</u>	<u>Cn-09 Data</u>
53P7	44	06.1
55P5	45	09.0
57P5	46	11.0
5011	47	17.0
5015	48	22.0
5018	49	27.0
5022	4A	32.0
5030	4B	41.0
5037	4C	52.0
5045	4D	62.0
5055	4E	77.0
5075	4F	99.0
5090	50	125.0
5110	51	144.0
5160	52	192.0

For Electronic Overload Protection  
 (Effective if Sn-14, Digit 1 = 0)

**5.5.1 Cn Constants Description (Continued)**

**Cn-09 : Motor Thermal Protection Characteristics (Standard Motor)**

IM : Actual Motor Current  
 IM100: Motor Base Current = Cn-09

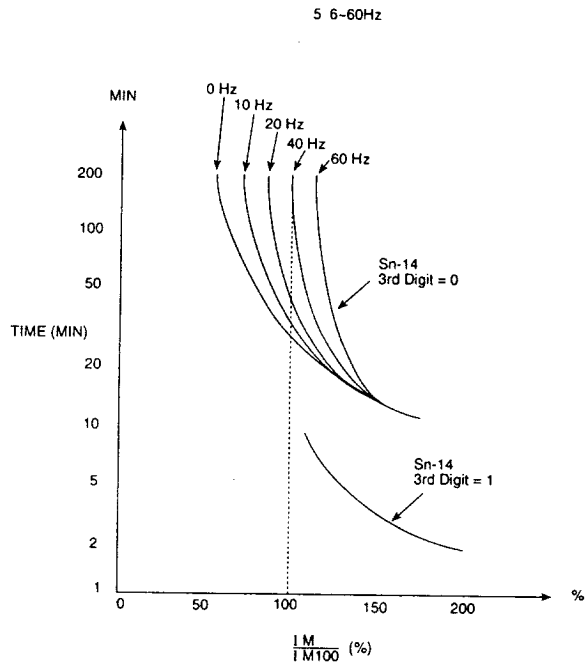

**Cn-09 : Electronic Motor Thermal Protection Characteristics  
 (Constant Torque Motor, Special Motor with External Blower)**

IM : Actual Motor Current  
 IM100: Motor Base Current = Cn-09

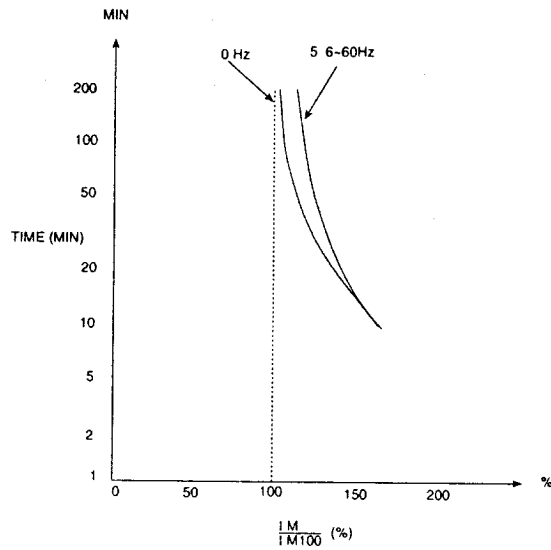

**5.5.1 Cn Constants Description (Continued)**

**Cn-10 : DC Braking Start Frequency**

Factory setting = 01.5 (Dependent on Sn - 02 setting).  
 Setting Range: 0.0 - 10.0 Hz  
 Setting Increment: 0.1 Hz  
 See timing chart at bottom of page.

**Cn-11 : DC Braking Current**

Factory setting = 050  
 Setting Range: 0 - 100%  
 Setting Increment: 1%  
 See timing chart at bottom of page.

**Cn-12 : DC Braking Time at Stopping**

Factory setting = 00.5  
 Setting Range: 0.0 - 25.5 sec  
 Setting Increment: 0.1 sec  
 See timing chart at bottom of page.

**Cn-13 : DC Injection Time at Starting**

Factory setting = 00.0  
 Setting Range: 0.0 - 25.5  
 Setting Increment: 0.1 sec  
 See timing chart at bottom of page.

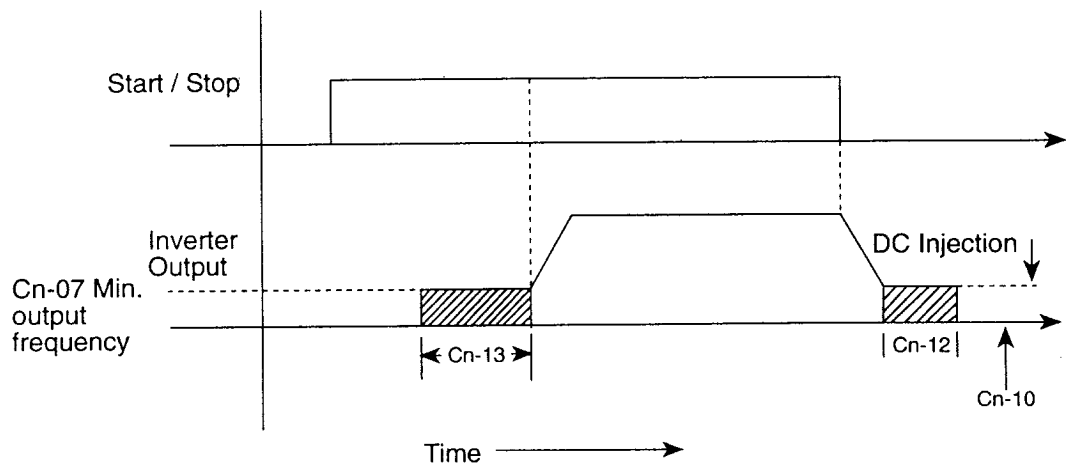

## 5.5.1 Cn Constants Description (Continued)

### Cn-14 : Frequency Speed Reference Upper Limit

Factory setting = 100  
 Setting Range: 0 - 108%  
 Setting Increment: 1%  
 Refer to the following graph.

### Cn-15 : Frequency Speed Reference Lower Limit

Factory setting = 000  
 Setting Range: 0 - 109%  
 Setting Increment: 1%  
 Refer to the following graph.

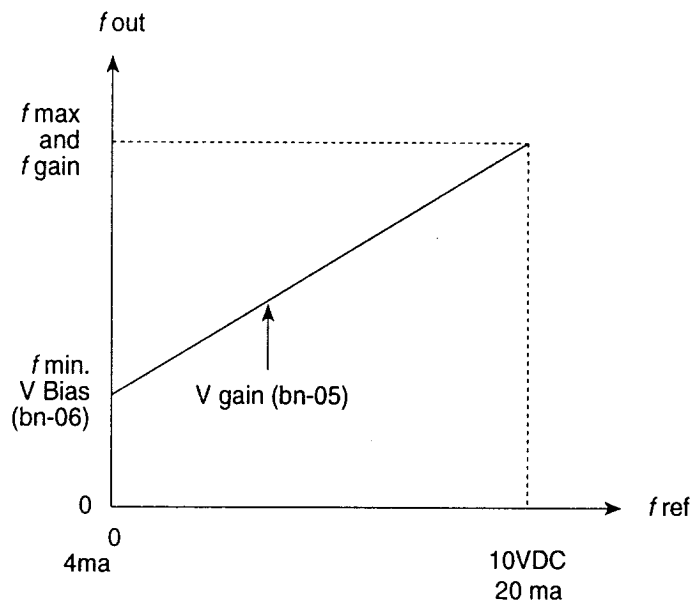
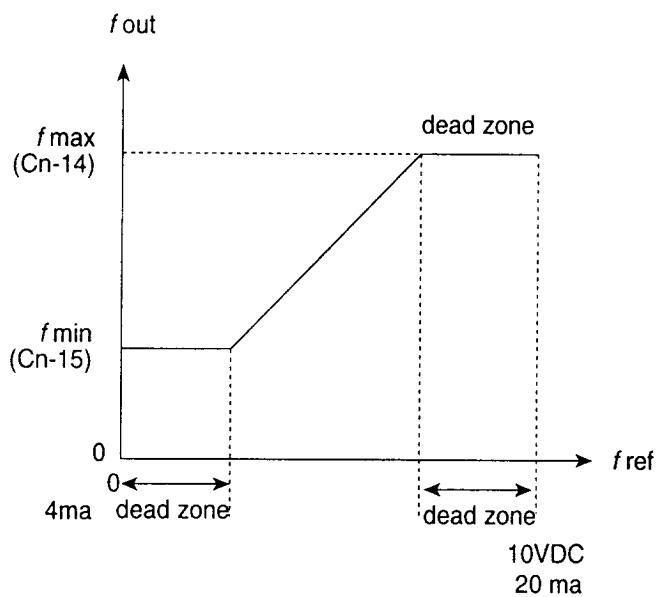

**5.5.1 Cn Constants Description (Continued)**

**Cn-16 : Setting Prohibited Frequency No. 1**

Factory setting = 000.0

**Cn-17 : Setting Prohibited Frequency No. 2**

Factory setting = 000.0

**Cn-18 : Setting Prohibited Frequency No. 3**

Factory setting = 000.0

More commonly referred to as "Frequency Jump". Programming these constants commands the inverter to avoid the particular output frequency set by each constant within a range of  $\pm$  Cn-19.

Setting Range: 0.0 to 400.0 Hz

Setting Increment: 0.1 Hz

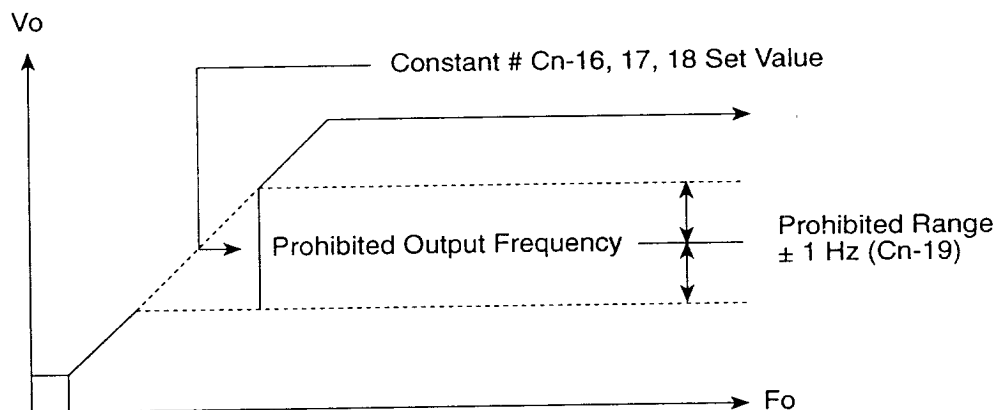

**Cn-19 : Set Prohibited Frequency Band Width**

Factory setting = 01.0

Setting Range: 0 - 25.5

Setting Increment: 0.1 Hz

## 5.5.1 Cn Constants Description (Continued)

### Cn-20 : Operator Display Mode

Factory setting - 00000

- = 0: DI Option  
Set in setting unit determined by Sn-26.
  
- = 1: DI Option  
Same as Cn-20 = 0.  
An-01 ~ 09: Set in the units of 0.01 Hz.
  
- = 2 ~ 39: Set in units of rpm (0 ~ 39999).  
 $\text{rpm} = 120 \times \text{frequency reference (Hz)} / \text{Cn-20}$ .
  
- = 40 ~ 39999: Decimal point determined by the value at 5th digit of Cn-20.  
5th Digit = 0 : XXXX displayed  
5th Digit = 1 : XXX.X displayed  
5th Digit = 2 : XX.XX displayed  
5th Digit = 3 : X.XXX displayed

100% frequency set value determined by Cn-20 1st to 4th digits.

Example 1: Cn-20 = 12000 when 100% speed set value is regarded as 200.0.

Example 2: Cn-20 = 26500 when 100% speed set value is regarded as 65.00.

---

### Cn-21 : Speed Agree Set Point

Factory setting = 000.0

Setting Range: 0 - 400.0 Hz

Setting Increment: 0.1 Hz

See Multi-Function Outputs (Page 54).

---

### Cn-22 Speed Agree Band Width

Factory setting = 02.0

Setting Range: 0.0 - 25.5 Hz

Setting Increment: 0.1 Hz

See Multi-Function Outputs (Page 54).

**5.5.1 Cn Constants Description (Continued)**

**Cn-23 : Carrier Frequency Upper Limit**

Factory settings: Model 20P4 - 2022 = 15.0  
 Model 2030 - 2075 = 2.0  
 Model 40P4 - 4030 = 15.0  
 Model 4037,4L45 = 10.0  
 Model 4045 = 2.5  
 Model 4055 - 4300 = 2.0  
 Model 53P7 - 5018 = 15.0  
 Model 5022 - 5055 = 10.0  
 Model 5075 - 5160 = 2.0

Setting Range: 0.4 - 15.0 kHz

Setting Increment: 0.1 kHz

Refer to the following graph.

**Cn-24 : Carrier Frequency Lower Limit**

Factory settings: Model 20P4 - 2022 = 15.0  
 Model 2030 - 2075 = 2.0  
 Model 40P4 - 4030 = 15.0  
 Model 4037,4L45 = 10.0  
 Model 4045 = 2.5  
 Model 4055 - 4300 = 2.0  
 Model 53P7 - 5018 = 15.0  
 Model 5022 - 5055 = 10.0  
 Model 5075 - 5160 = 2.0

Setting Range: Limited by Cn-23 / Cn-25

Setting Increment: 0.1 kHz

Refer to the following graph

**Cn-25 : Carrier Frequency Proportional Gain**

Factory setting = 00

Setting Range: 0 - 99

Setting Increment: 1

Refer to the following graph.

**Cn-23 : through 25 (Continued)**

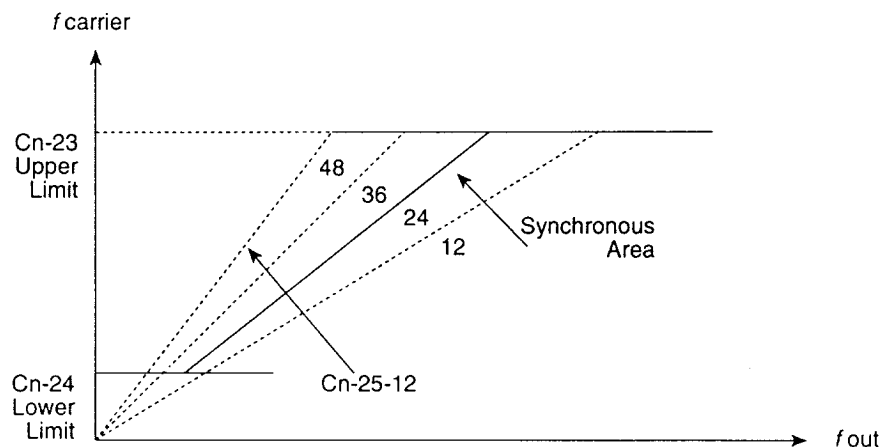

## 5.5.1 Cn Constants Description (Continued) Cn-23 through 25 (Continued)

Cn-23 Upper Limit (kHz)	Number of Pulses Per Cycle
>12.5	Cn-25 x 6
10.0 to 12.5	Cn-25 x 5
7.5 to 10.0	Cn-25 x 4
5.0 to 7.5	Cn-25 x 3
2.5 to 5.0	Cn-25 x 2
Up to 2.5	Cn-25 x 1

If Cn-25 is 6 or less, carrier is constant. Synchronous mode if 12, 24, 36, or 48 is set in Cn-25.

Note: OPE 11 fault display will occur in the following cases:

- (1) Cn-25 > 6 and Cn-24 > Cn-23
- (2) Cn-23 > 5kHz and Cn-24 ≤ 5 kHz

### Cn-26 : Overtorque Detection Level

Factory setting = 160  
 Setting Range: 30 - 200%  
 Setting Increment: 1%  
 Refer to following graph.

### Cn-27 : Overtorque Detection Time

Factory setting = 01.0  
 Setting Range: 0.0 - 25.5 seconds  
 Setting Increment: 0.1 seconds  
 Refer to following graph.

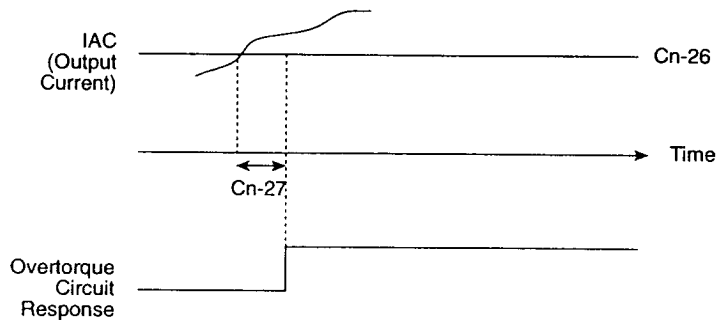

See Sn-20 to Sn-22 for response alternatives (Page 54)



**5.5.1 Cn Constants Description (Continued)**

**Cn-28: Stall Prevention During Acceleration (Constant Torque)**

Factory setting = 170

Setting Range: 30-200%

Setting Increment: 1%

Refer to Sn-10 (Page 36).

**Cn-29: Stall Prevention Level During Acceleration (Constant Hp)**

Factory setting = 050

Setting Range: 30-200%

Setting Increment: 1%

Refer to Sn-10 (Page 36).

**Cn-30: Stall Prevention Level During Running**

Factory setting = 160

Setting Range: 30 - 200%

Setting Increment: 1%

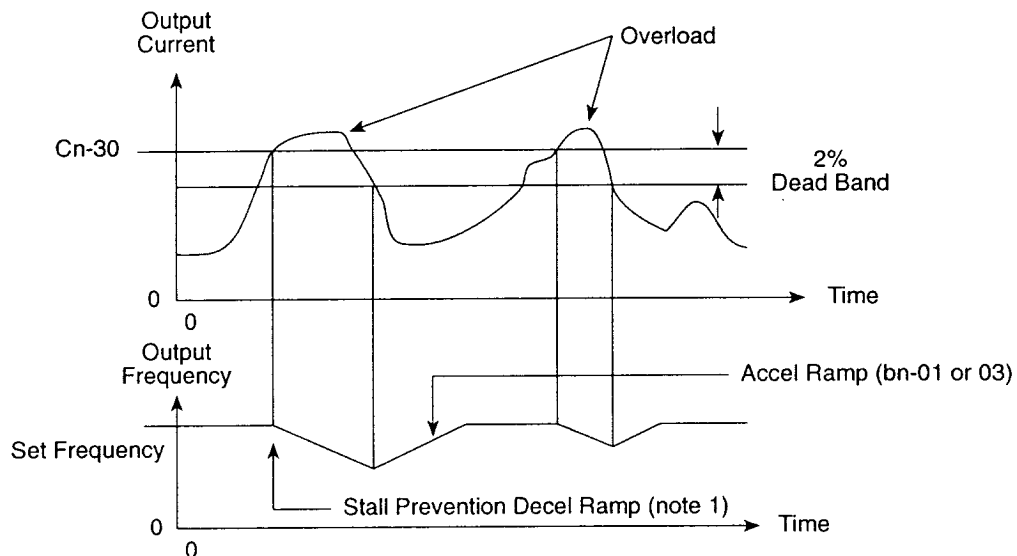

1: Decel rate is bn-02 or bn-04. Selected by Sn-10 (Page 37).

## 5.5.1 Cn Constants Description (Continued)

### Cn-31: Motor Cable to Cable Resistance

Factory setting: dependent on Sn - 01 setting.  
 Setting Range: 0.000 - 65.535  
 Setting Increment: 0.001 Ohm  
 Refer to the following graph.

### Cn-32: Iron Loss

Factory setting: dependent on Sn - 01 setting.  
 Setting Range: 0 - 65535 W  
 Setting Increment: 1W  
 Refer to the following graph.

### Cn-33: Torque Compensation limiter

Factory setting: dependent on Sn - 01 setting.  
 Setting Range: 0 - 50V (230V Series)  
 0 - 100V (460V Series)  
 0 - 125V (575 Series)

Compensated Value ~ (  $\frac{\sqrt{3} \text{ Vac Iac Cos } \phi - \text{ WI} - \text{ Rcable}}{\text{Frequency}}$  ) x Kt  
 WI = Cn-32  
 Rcable = Cn-31  
 Kt = bn-07  
 Refer to the following graph.

## Cn-31, 32, 33 ( Continued)

Full Range, Automatic Torque Compensation

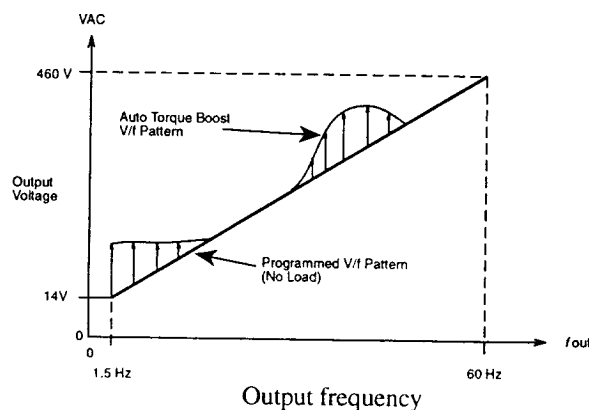

**5.5.1 Cn Constants Description (Continued)**

**Cn-34: Motor No-Load Current**

Factory setting = 30

Setting Range: 0 - 99%

Setting Increment: 1%

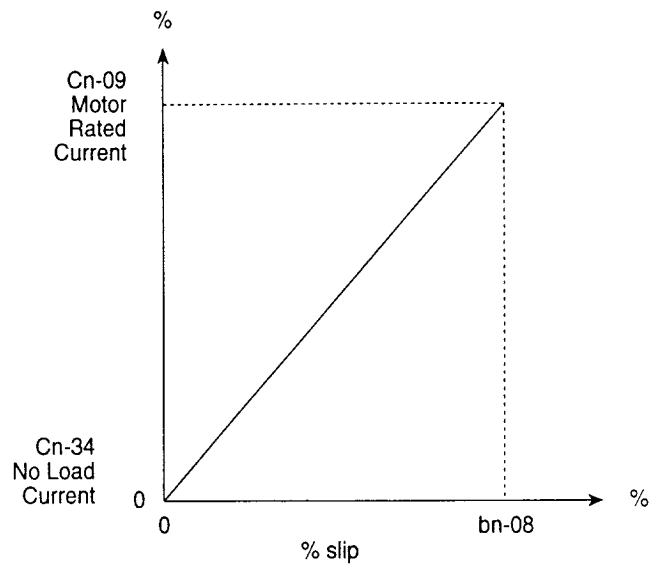

Example:

If bn-08 = 5%

IAC = Cn-09 (Motor rated Current)

f out = Set value x 1.05

**Cn-35: Slip Compensation Time Delay**

Factory setting = 00.0

Setting Range: 0.0 - 25.5 seconds

Setting Increment: 0.1 seconds

Slip compensation circuit has no accel/decel ramp. This allows dampening of the circuit.

## 5.5.1 Cn Constants Description (Continued)

### Cn-36: Number of Auto Restart Attempts

Factory setting = 00

Setting range: 0 - 10

Setting Increment: 1

Determines number of attempts to automatic restart the inverter will perform.

The following faults are included:

- OC: Overcurrent
- OV: Overvoltage
- OL1: Motor overload
- OL2: Inverter overload
- OL3: Overtorque
- OH: Overheat
- UV1: Undervoltage

#### Notes:

UV fault must be selected at Sn-11, 3rd digit = 0

Will not restart if OC or OV occurs during deceleration.

Number of faults resets if:

- (1) 10 minutes elapses without a fault.
- (2) The reset button is depressed.

#### Retry Operation at Fault

- (1) When a fault is detected, the inverter output is shut off for the minimum base block time (Cn-40). While the inverter output is shut off, the fault which has occurred is displayed on the operator.
- (2) When the minimum base block time (Cn-40) passes, the fault is reset automatically and speed search operation is performed at the output frequency when the fault occurred.
- (3) If the total number of faults exceeds the number of retries (Cn-36), inverter output is shut off without being reset automatically. The fault contact is then energized.

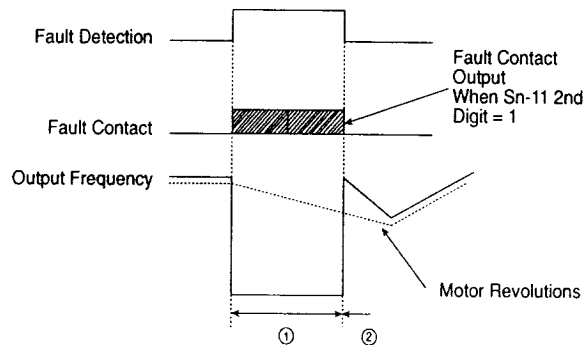

**5.5.1 Cn Constants Description (Continued)**

**Cn-37: Power Loss Ride Through Time**

Factory setting is dependent on Sn - 01 setting.

Setting Range: 0.0 - 2.0 seconds

Setting Increment: 0.1 seconds

230V/460V ≤ 2HP: 1.0 seconds

230V/460V > 2HP : 2.0 seconds

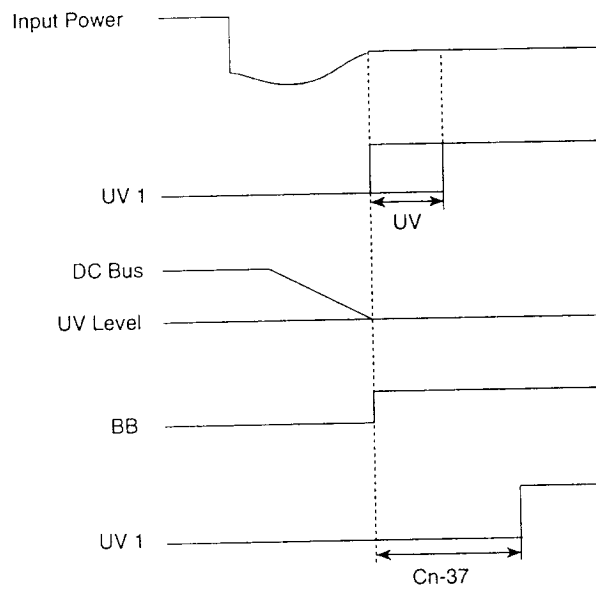

$$\text{Approx. } \Delta t = \frac{C \Delta V}{I}$$

$$2X : \begin{matrix} 100V \text{ drop} \\ C = 6600 \text{ MF} \\ I = 37A \end{matrix} = \frac{(6600 \times 10^{-6})(100V)}{37A} = 0.018 \text{ sec.}$$

**Cn-38: Speed Search Operation Level**

Factory setting = 150

Point at which inverter will resume acceleration during a speed search operation.

Setting Range: 0 - 200%

Setting Increment: 1%

Refer to the following timing chart (Page 78).

## 5.5.1 Cn Constants Description (Continued)

### **Cn-39: Speed Search Decel Time**

Factory setting = 02.0

Deceleration rate of inverter frequency during a speed search operation.

Setting Range: 0 - 25.5 seconds

Setting Increment: 0.1 seconds

Refer to the following timing chart (Page 78).

---

### **Cn-40: Minimum Baseblock Time**

Factory setting is dependent on Sn - 01 setting.

Minimum transistor off time to allow collapse of residual voltage before restarting during speed search or DC injection.

Refer to the following timing chart (Page 78).

---

### **Cn-41: V/f During Speed Search**

Factory setting = 100

Reduces inverter V/f ratio during speed search. Can help prevent OC trips.

Setting Range: 0 - 100%

Setting Increment: 1%

---

### **Cn-42: Voltage Recovery Time**

Factory setting = 0.3

Sets the time for inverter to reapply appropriate voltage during a speed search.

Setting Range: 0.1 - 2.0 seconds

Setting Increment: 0.1 seconds

Refer to the following timing chart (Page 78)

**5.5.1 Cn Constants Description (Continued)**  
**Speed Search After Undervoltage**

Time Chart at recovery from momentary power failure is shown below:

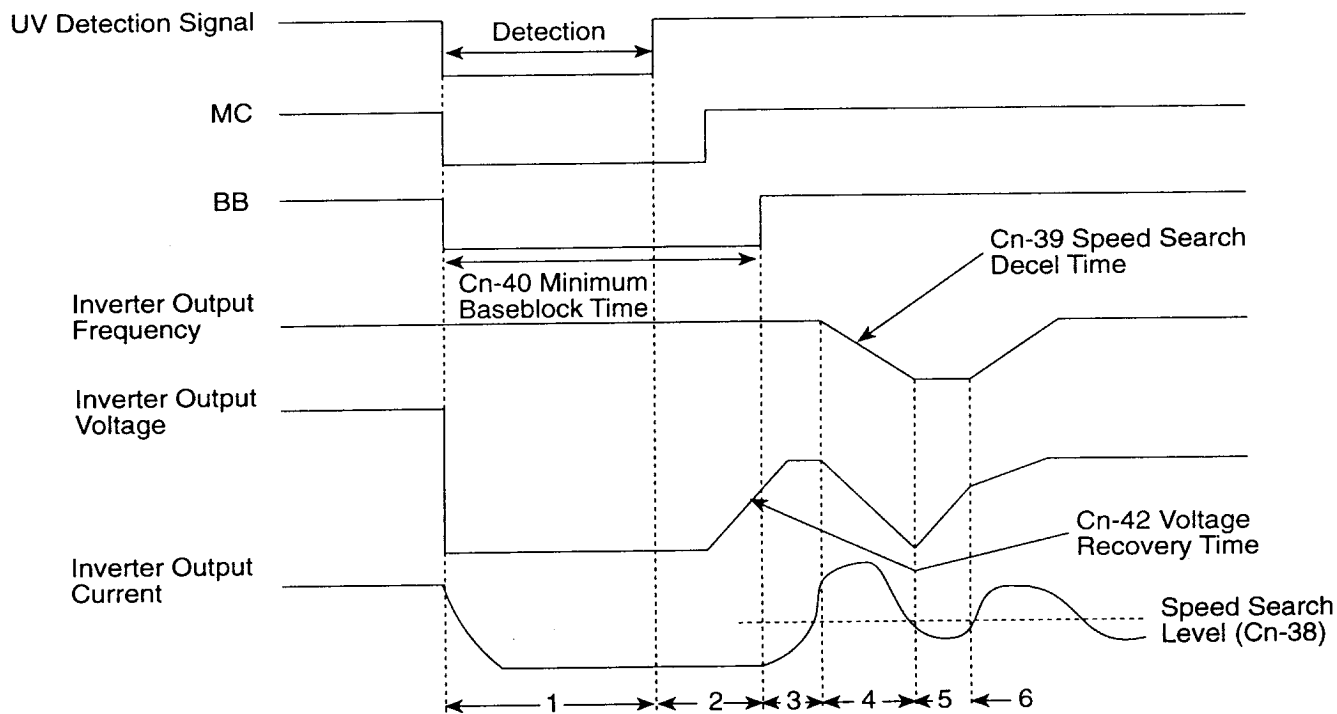

# SAFTRONICS

## 6.0 USING THE DIGITAL OPERATOR FOR PROGRAMMING

The Saftronics G3+ unit An and bn constants can be changed while the drive is running.

EXAMPLE #1: You want to change Jog Frequency from 6.0 Hz to 10.0 Hz.



Find An constant number for jog frequency reference (An-09).

Press  key until An-01 is displayed.

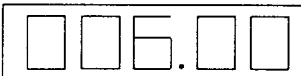

Press  key until An-09 is displayed.

When An-09 is displayed, press  key.

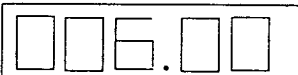
Display will read 

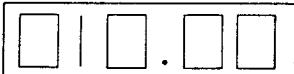
Use  and  key to change  to

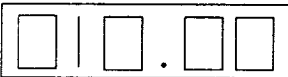

When display reads  press  key

and display will read END momentarily.

Jog frequency is now set to 10.0Hz.

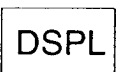
Press  key to scroll to display desired.

The Saftronics G3+ Units Sn and Cn constants can be displayed while running but not changed while running.

EXAMPLE #2: You want to read which V/F pattern is programmed into unit (Sn-02).

Press  and  key at the same time.

Sn-01 will be displayed, press  key until display reads Sn-02.





6.0 USING THE DIGITAL OPERATOR FOR PROGRAMMING (CONTINUED)



Press  key to read data programmed into Sn-02.

Display will read  (Factory Setting).

This is a standard general purpose 60Hz saturation V/F pattern.

Press  key to go back to desired read-out.

Follow same steps for reading Cn constants, except after pressing 

and  key, and Sn-01 is displayed, press  key until Cn-01 is displayed.

The Saftronics G3+ units constants Sn and Cn can be changed only when drive is in the stop mode.

Changing Sn Constants:

EXAMPLE #3: Customer wants to run motor at 90 Hz.



Locate Sn constant for V/f pattern selection (Page 26 and 27) Sn-02.

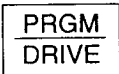

Sn-02 has 15 pre-programmed V/F patterns in the hardware (Page 26 and 27).

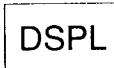
V/F Pattern "0C" is a 90Hz V/F pattern

With the drive stopped, press  key, display will read An-01

Press  key until the display reads Sn-01.

Use   key so that display reads Sn-02.

Press  key, and display will read  (Factory Setting).

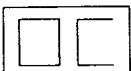
Use  key until display reads 

Press  key and display will momentarily read END.

# SAFTRONICS

## 6.0 USING THE DIGITAL OPERATOR FOR PROGRAMMING (CONTINUED)

V/F pattern is now changed to 90Hz.

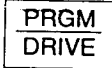
Press  key and the unit is now ready to run.

Changing Cn-constants. Cn constants can be changed only when the drive is stopped.



EXAMPLE #4: Customer has a fan application and wants to prevent "wind mill effect" by applying DC injection braking before starting the motor.

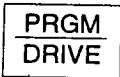

Find DC injection braking time at start (Cn-13) (Page 63)

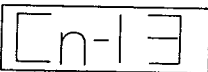
Press  key, display will read An-01.

Press  key until  is displayed.

Press  key until  is displayed.

Press  key and display will read  (Factory Setting).

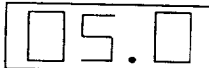
Use   keys to change display to .

Press  key and display will briefly read END. Now unit has 5 seconds of DC injection braking at start command.

Press  key, now unit is ready to run.

**7.0 BASIC PROGRAMMING FOR START UP AND TYPICAL APPLICATIONS**

Before operating the drive it is important to set up a few drive parameters, ie:

Input voltage: Cn-01

Program measured input voltage into Cn-01.

Setting electronic thermal overload: Cn-09

Check the motor nameplate data for Full Load Amps and program into Cn-09.

The Saftronics G3+ inverter uses an electronic overload that will allow 150% of Cn-09 value for 1 minute. This is a frequency dependent, inverse time to trip overload. This means the inverter will allow 150% of Cn-09 at 60Hz. The inverter knows that if you are running at 30Hz the cooling capability of a standard TEFC motor is reduced, so the trip point is automatically lowered. If you have a special motor designed to run at low speeds for a long time, select Sn-14 digit 2=1. This gives protection characteristics for an Inverter duty rated motor or a motor with a separate blower mounted on it.

Cn-09: Motor Thermal Protection Characteristics  
(Std. Motor)

IM: Actual Motor Current  
IM100: Motor Base Current = Cn-09

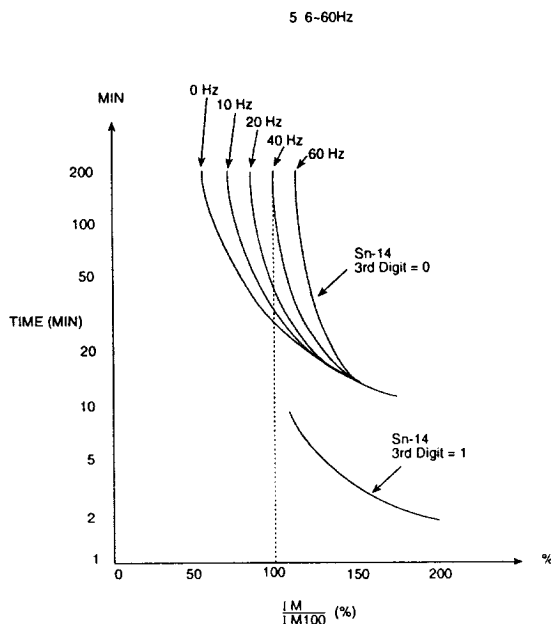

Cn-09: Electronic Motor Thermal Protection Characteristics  
(Con. Torque Motor)

IM: Actual Motor Current  
IM100: Motor Base Current = Cn-09

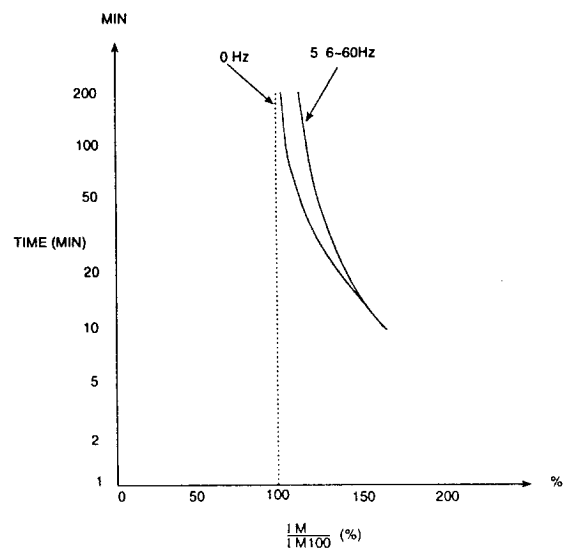

## 7.0 BASIC PROGRAMMING FOR START UP AND TYPICAL APPLICATIONS (CONTINUED)

EXAMPLE #1: Application requires DC injection braking before accelerating to prevent "Windmilling Effect" (Cn-13).

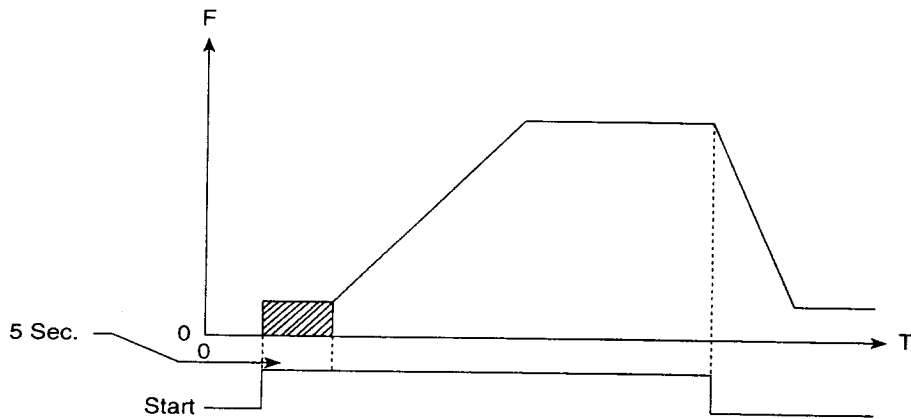

Cn-13 = 05.0

When start command is given, the Inverter will inject DC voltage into motor for 5 sec to bring motor to zero speed before accelerating.

EXAMPLE #2: Application requires Drive to skip over or not run at certain known resonant frequencies.

Resonant frequency of machine = 45 Hz.

Cn-16 = 045.0

The Inverter will not run at 45Hz even if operation sets speed at 45Hz. The digital Programmer will not accept a speed setting equal to Cn-16, The inverter will Accelerate and Decelerate through set Frequency (Cn-16).

NOTE: 3 Prohibited frequencies can be set (Cn-16, 17 and 18). Also a prohibited frequency bandwidth can be set (Cn-19).

EXAMPLE #3: Application requires that drive have an auto-reset after a Fault (Cn-36).

Program into Cn-36 the number of resets desired up to 10.

Drive will not reset on CPF or FU Faults.

**7.0 BASIC PROGRAMMING FOR START UP AND TYPICAL APPLICATIONS**

**EXAMPLE # 4:** Application requires that the Inverter give an output contact closure after drive has reached a certain speed.

Program Sn-20 = 05, then Program Cn-21 to the frequency that a contact will be made.

**EXAMPLE:** Contact Closure at 30 Hz

Sn-20 = 05

Cn-21 = 030.0

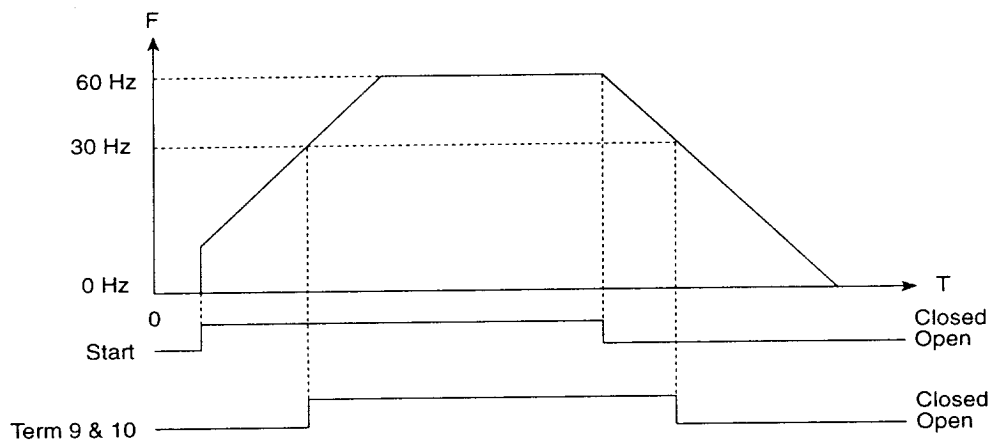

**EXAMPLE #5:** Application requires an output contact when External Fault is Detected. Application requires that Drive accept an external Fault Command.

**EXAMPLE :** N.O. Contacts from Lubrication Pump. If contact closes due to pump failure, Drive will Baseblock output transistors and motor will coast to a stop. Display will read Eb.

**EXAMPLE #6:** Application requires large break away torque.

Increase bn-07 value by 0.1 increments, until sufficient torque is achieved.

**EXAMPLE #7:** Application requires that drive can monitor output current by a remote meter.

Use a 1 amp full scale deflection meter and wire to terminals 21 and 22.

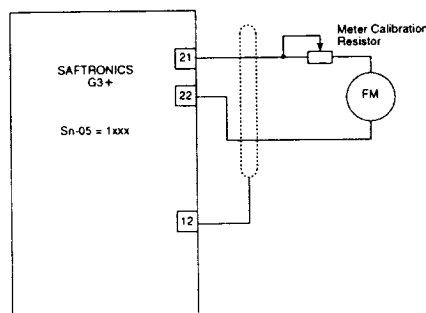

## 8.0 PROGRAMMING FOR EXTERNAL CONTROL

### Remote Start/Stop with speed control from Digital Operator

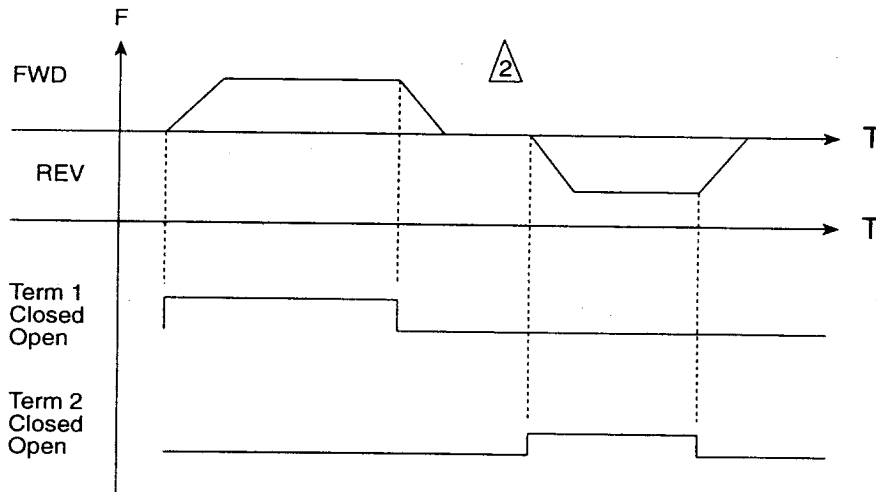
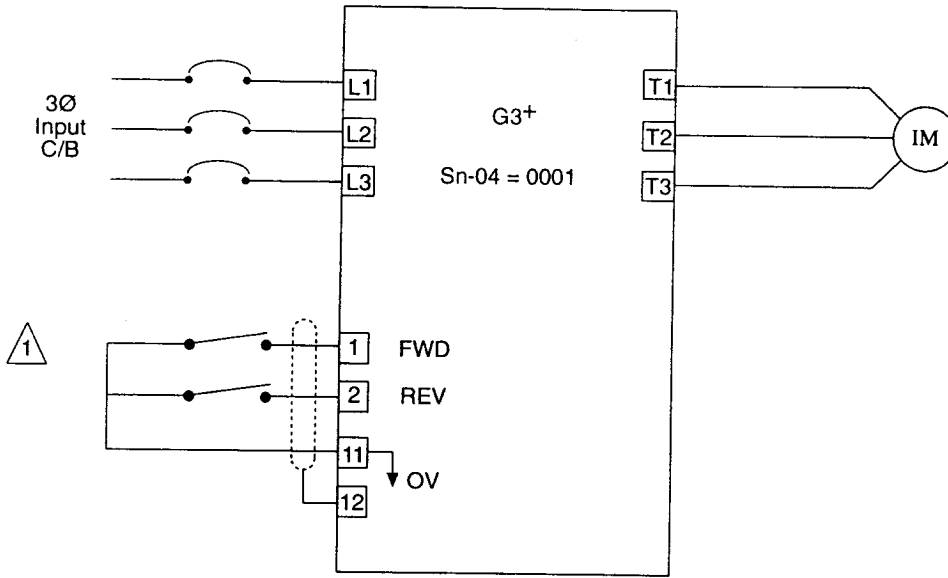

1 NOTE: 2 wire control. Use Latched Contact.

2 NOTE: Delay between change of direction is not necessary.

8.0 PROGRAMMING FOR EXTERNAL CONTROL (CONTINUED)

Remote Start/Stop with Speed Pot

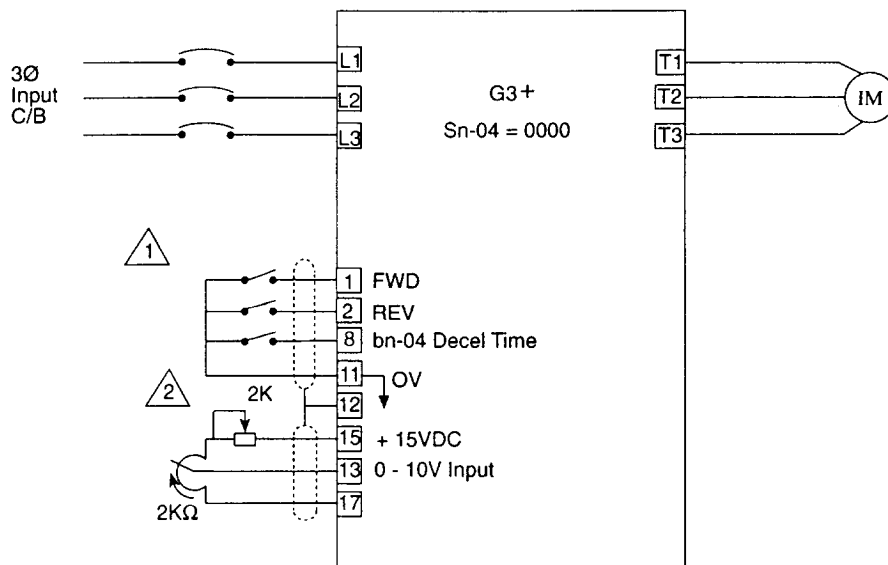

Remote Start/Stop with 0 - 10VDC Speed Signal

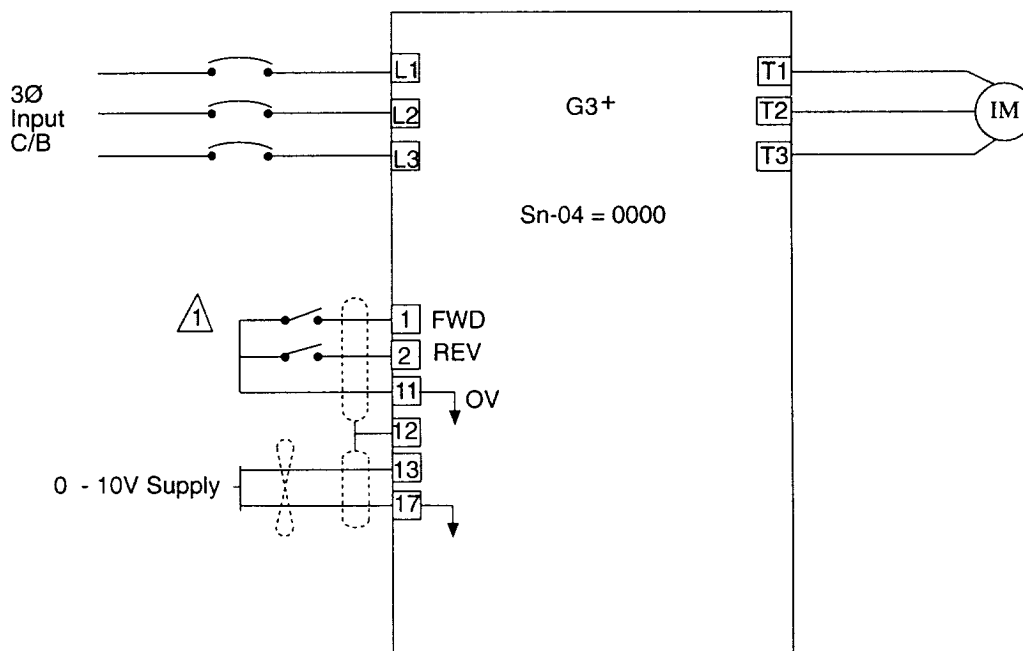

△1 NOTE: 2 wire control. Use latched contacts.

△2 Trim Resistor. Use Trim resistor to trim +15VDC with speed pot at MAX otherwise, you will have a "deadband" on the upper end of speed pot.

# SAFTRONICS

## 8.0 PROGRAMMING FOR EXTERNAL CONTROL (CONTINUED)

### Multi-Speed Operation - 9 preset speed

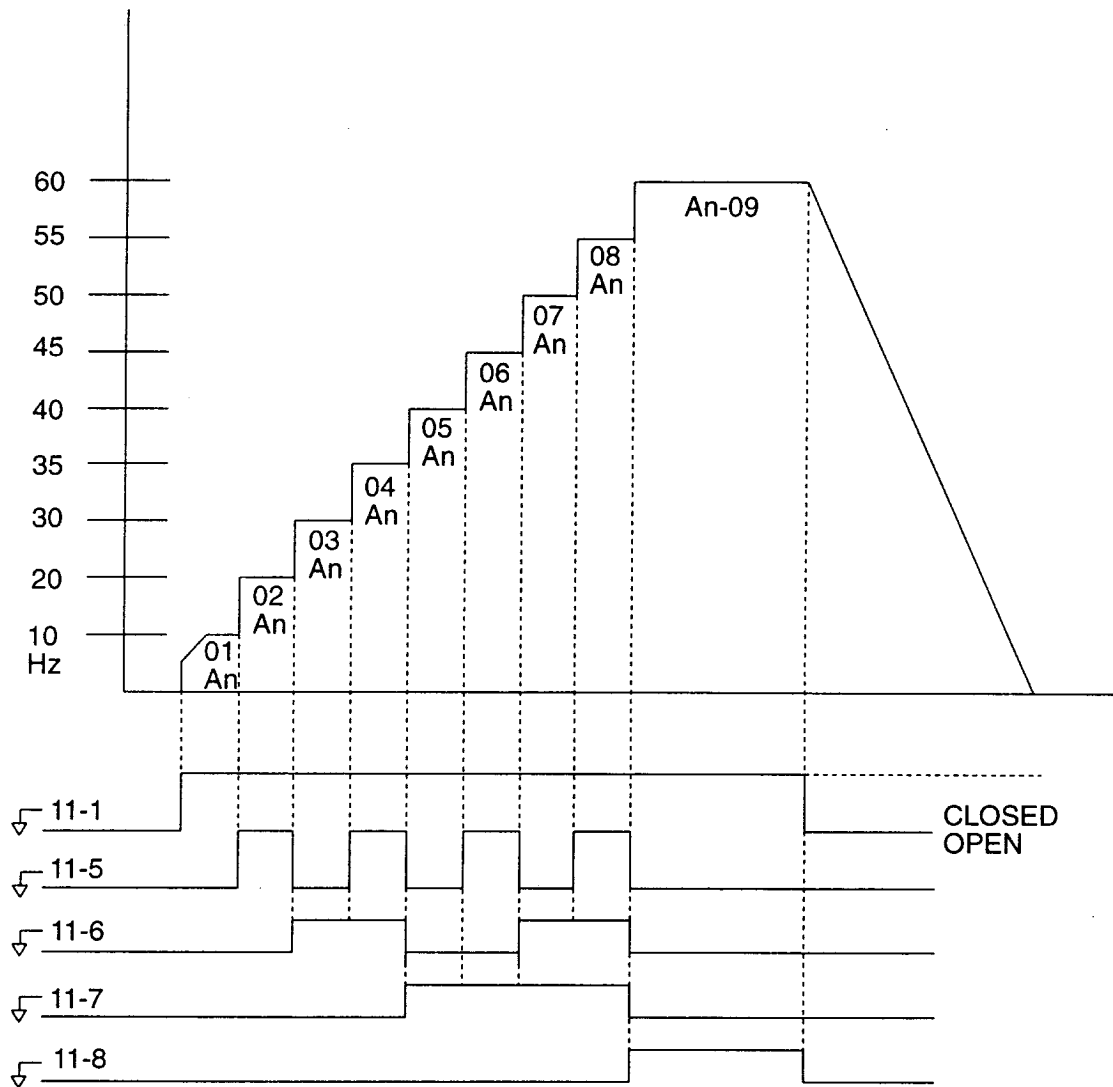

### Programming

An -01 = 10 Hz	Sn-04 = 0001
An -02 = 20 Hz	Sn-15 = 03 term 5
An -03 = 30 Hz	Sn-16 = 04 term 6
An -04 = 35 Hz	Sn-17 = 05 term 7
An -05 = 40 Hz	Sn-18 = 06 term 8
An -06 = 45 Hz	Sn-19 = 0F
An -07 = 50 Hz	
An -08 = 55 Hz	
An -09 = 60 Hz	



8.0 PROGRAMMING FOR EXTERNAL CONTROL (CONTINUED)

Remote Speed Control by 4-20 MA transducer/generator with REV Lockout

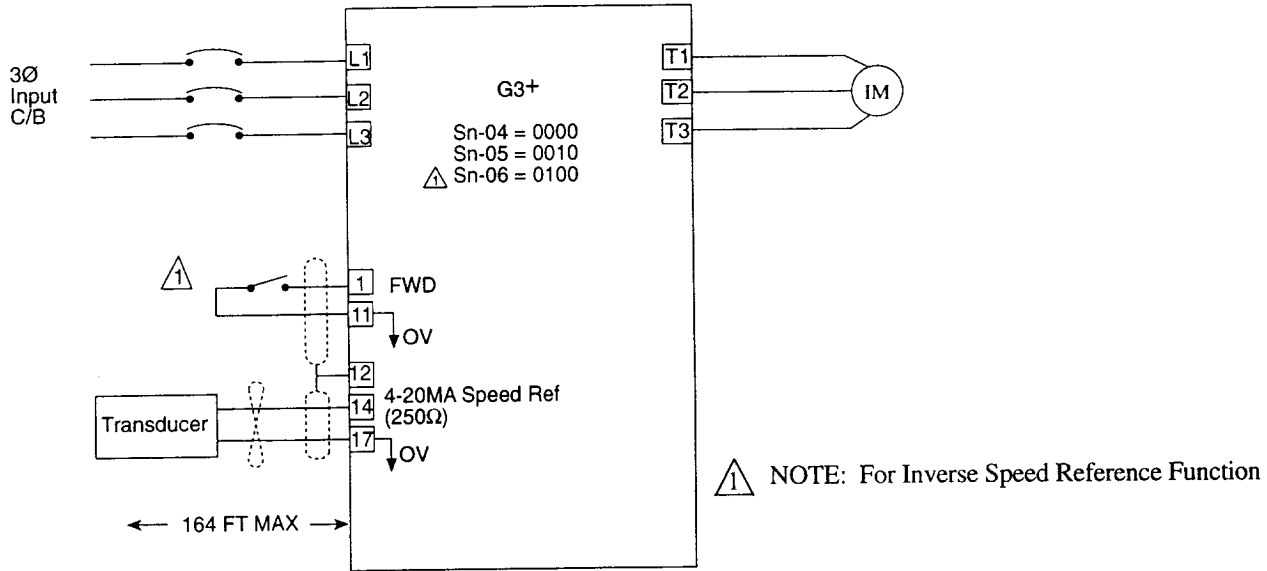

2 separate selectable Decel Time

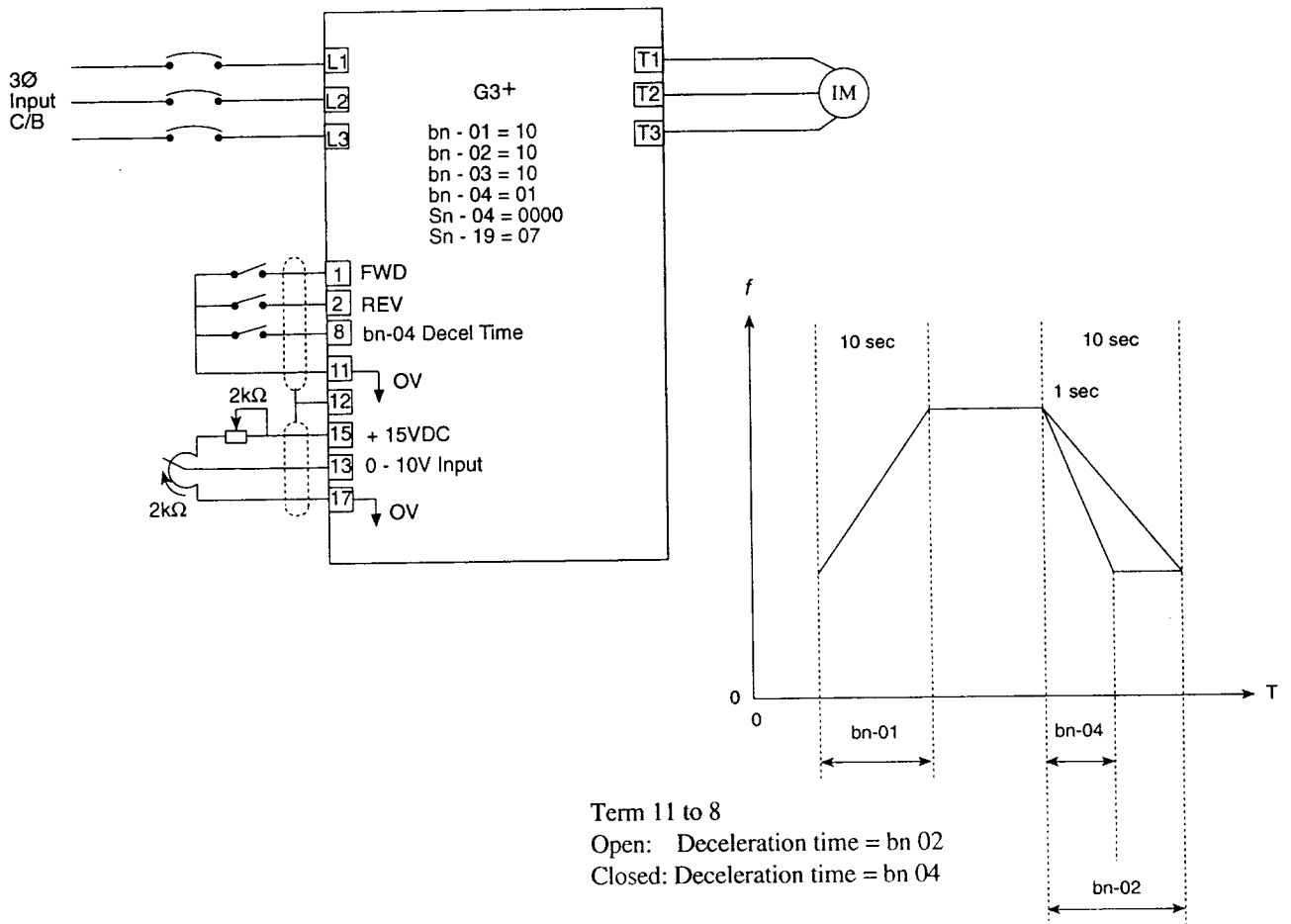

## 8.0 PROGRAMMING FOR EXTERNAL CONTROL (CONTINUED)

**Using Dynamic Brake Packages** (braking module built-in as standard)

- 230V 20P4-27P5 (10HP and below)
- 460V 40P4-4015 (20HP and below)
- 575V 53P7-5018 (25HP and below)

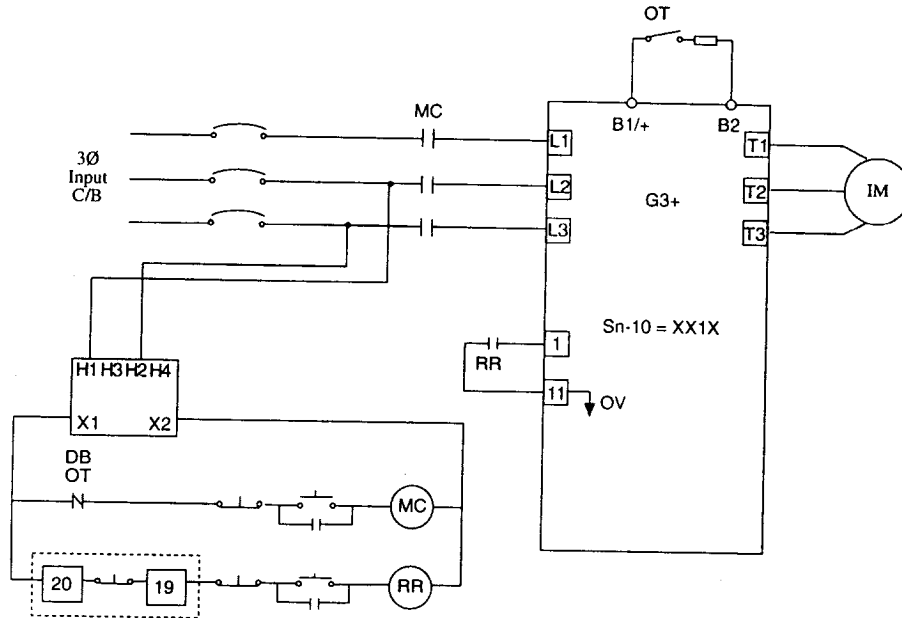

### MC Contactor Purpose:

If the Drive is not running, but power is on, the input voltage could rise and turn on the Braking Transistor 100% of the time and cause the braking resistor to burn up and/or transistor failure. The thermal O/L should trip and open MC Contactor removing power. It is recommended that when the Inverter is not in use to remove power. Removing input power by opening MC Contactor also protects unit if lightning strikes power distribution by isolating the Drive from distribution center.

If thermal O/L opens while the Drive is running, it will turn the Drive off and the motor will coast to stop.

8.0 PROGRAMMING FOR EXTERNAL CONTROL (CONTINUED)

Using Dynamic Brake Packages

230V 2011-2075 (15HP to 100HP)

460V 4018-4300 (25HP to 400HP)

575V 5022-5160 (30HP to 200HP)

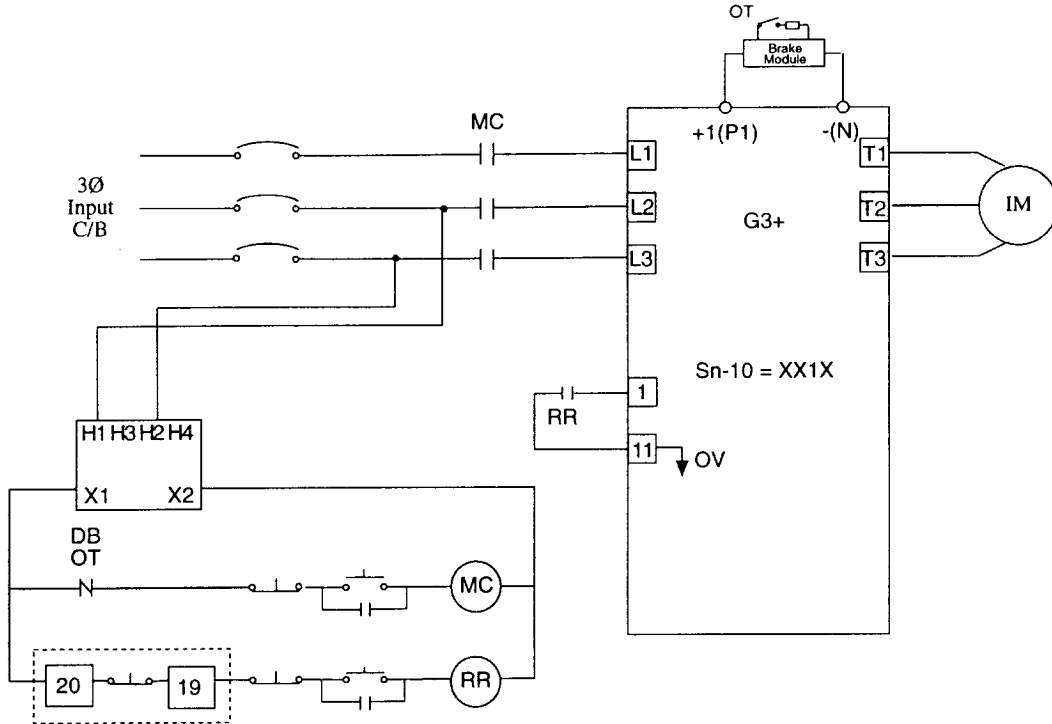

MC Contactor Purpose:

If the Drive is not running, but power is on, the input voltage could rise and turn on the Braking Transistor 100% of the time and cause the braking resistor to burn up and/or transistor failure. The thermal O/L should trip and open MC Contactor removing power. It is recommended that when the Inverter is not in use to remove power. Removing input power by opening MC Contactor also protects unit if lightning strikes power distribution by isolating the Drive from distribution center.

If thermal O/L opens while the Drive is running, it will turn the Drive off and the motor will coast to stop.

# SAFTRONICS

## 9.0 FAULT INDICATIONS

FAULT DISPLAY	PROTECTIVE FUNCTIONS	CAUSE / SOLUTION			
			230V Series	460V Series	575V Series
Uv1 (UV1)	DC bus voltage low	Incoming 3Ø main below: DC bus voltage below:	180 VAC 210 VDC	342 VAC 420 VDC	450 VAC 525 VDC
Uv2 (UV2)	Control Voltage is low	- Control fuse bad / replace fuse: Power supply on card faulty / replace card			
Uv3 (UV3)	Pre-charge contact has no answer contact	Pre-charge resistor open MC contactor coil bad			
oC (OC)	1. Inverter output current has exceeded 200% of Inverter Rated Current 2. Ground fault protection	1. Acceleration time too short/ Lengthen acceleration time Inverter too small/  2. Ground fault on output/ Clear Fault			
ou (OV)	DC Bus Voltage too high	Incoming 3Ø main above : DC bus voltage above :	253VAC 400VDC	506VAC 800VDC	633VAC 1000VDC
FU (FU)	DC bus fuse is open. 99.9% chance of damaged transistors. Fuse clears to protect Inverter, not transistor. DO NOT replace fuse until transistors are checked and replaced.	- Repeat OC trips, motor's bad and / or faulty base drive circuits.			
oH (OH)	Inverter heatsink has exceeded 90° C	- Bad fan-replace fan. - Dirty heatsink, clean heatsink. - Ambient temp too high, reduce ambient temp: - Fan filters clogged, clean / replace filters.			
oL 1 (OL1)	Motor protection. Output current has exceeded 150% for 1 min. of Cn-09 value.	- Cn-09 value too low, use FLA data from motor for Cn-09 data. - Motor is overloaded, clear overload condition . -Motor is operated at low speed for extended time, use special motor and select Snd- 14 : 0010			

**9.0 FAULT INDICATIONS (CONTINUED)**

FAULT DISPLAY	PROTECTIVE FUNCTION	CAUSE / SOLUTION
oL 2 (OL2)	Inverter Protection. Output current has exceeded 112% of inverter rated current.	-Unit size too small, use larger inverter.
oL 3 (OL3)	Indication that inverter has exceeded over torque value in Cn-26.	
rr (r)	Internal braking transistor faulty.	- DB resistor value too low, increase. - DB resistance, use larger inverter. - Duty cycle too high, use larger inverter - Faulty motor, check motor.
rH (rH)	230V units 5 HP (3.7kW) or lower. 460V units 3 HP (2.2kW) or less. Optional DB resistor that mounts to heatsink, has overheated.	- Duty cycle too high - Ambient temp too high - Insufficient air flow across DB resistors.
EF <input type="checkbox"/>	3 External fault received on terminal 3. 5 External fault received on terminal 5. 6 External fault received on terminal 6. 7 External fault received on terminal 7. 8 External fault received on terminal 8.	- Check Un-07 input terminal status. If "1" is indicated on display, but term has open condition, drive is faulty.  - Clear external Fault
CPF00	Transmission hardware faulty	- Transmission between G3+ and operator cannot be executed 5 seconds after power is applied. Replace unit
CPF01	Transmission Failure	- When transmission error occurs 2 seconds after transmission occurs.  -Replace Inverter.
CPF 02	Control circuit failure	- Replace Inverter.
CPF 03	NV-RAM failure	- Replace Inverter.
CPF 04	NV-RAM (BCC, Access Code)	- Perform initialization. See Sn-03 Page 29.

## 9.0 FAULT INDICATIONS (CONTINUED)

FAULT DISPLAY	PROTECTIVE FUNCTION	CAUSE / SOLUTION
CPF 05	A/D converter failure in CPU	- Check and secure option connections
CPF 06	Option A/D converter fault	- Replace option card
CPF 20	Sn-01 setting fault	- When 460V constant is set for 230V class inverter and vise-versa. - Check Sn-01 data Page 26.
oPE01	kVA constant setting fault	-460V Series constant is set into 230V Series or vice-versa.
oPE 02	Constant setting range	-A constant value has been set that is outside that contants parameters. Check constants setting range.
oPE 03	Multi-function input setting fault	- Sn-15 ~ Sn-18 are not arranged in ascending order. -Both speed search references "61" and "62" are set. -UP command "10" and DOWN command "11" are set simultaneously. -UP command "10", DOWN command "11", or accel prohibit command "0A" are set simultaneously.
oPE 10	V/F data fault (Cn ~ 02-Cn-08) Cn-02 ~ Cn-08 do not satisfy the following conditions $Cn-02 \geq Cn-04 > Cn-05 \geq Cn-07$	<p>The graph illustrates the V/F characteristic. The vertical axis is Voltage (V) and the horizontal axis is Frequency (f). The curve starts at a minimum voltage Cn-08 (V MIN) at a minimum frequency Cn-07 (F MIN). It rises linearly to a maximum voltage Cn-03 (V MAX) at a frequency Cn-04 (FA). At this frequency, the voltage is also Cn-06 (VC). The frequency Cn-05 (FB) is marked on the x-axis, and the voltage at this frequency is Cn-06 (VC). The frequency Cn-02 (F MAX) is marked on the x-axis, and the voltage at this frequency is Cn-03 (V MAX). The curve then remains constant at Cn-03 (V MAX) up to Cn-02 (F MAX).</p>
oPE 11	Constants set fault	- Cn-23 > 5k Hz and Cn-24 ≤ 5k Hz - Cn-25 > 6 and Cn-23 < Cn24

**10.0 ELEMENTARY DIAGRAM DESCRIPTION**

COMPONENT	FUNCTION
MOV"S	<p>MOV'S (metal oxide varistors) are located on the input side of inverter, connected phase to phase. MOV"S are designed to protect electrical equipment from voltage surges or transients.</p>
(DM1) Diode Bridge	<p>The inverter has a diode front, which converts incoming AC voltage to a DC voltage.</p> <p>A shorted diode bridge will usually cause input fuses or C/B to trip upon power up.</p> <p>An open diode bridge will not let DC bus charge up to proper operating level and will display a UU fault.</p> <p>Check the diode by using an ohm meter in the RX1 scale. Measure from AC input to the (+) positive output, and from AC input to (-) negative output swapping leads on each. Resistance will be low in one direction and very high in other direction.</p> <p>NOTE: When replacing diode bridge it is important to use a thermal component to heatsink. Failure to do this will result in shortened device life.</p>
Precharge Resistor and Main Circuit	<p>The precharge resistor and MC contactor work together to provide a "soft-charge" circuit to the DC bus. Applying a DC voltage directly into a capacitor causes large in-rush currents. To eliminate the in-rush current a resistor is put in between the (+) positive side of diode bridge and the DC bus, to slow charge DC bus. Once the DC bus is charged to a specific level, voltage is applied to the coil of the MC contactor and shorts out resistor, taking it out of circuit.</p> <p>The inverter will usually display a UU fault when this circuit is faulty.</p> <ol style="list-style-type: none"> <li>1. Check resistor by ohming out across the input and output of MC contactor. Look for open circuit.</li> <li>2. If digital operator responds slowly to a command or if LED segments are dim check MC contactor coil to see if coil is open. Also check for mechanical damage by pressing activator on contactor to ensure free movement and proper seating of contacts.</li> <li>3. On the larger inverter units (15HP and above) an answer contact is used to verify that the coil has been energized and the contactor has pulled in. If an answer contact is not received a UU3 will be displayed.</li> </ol>

# SAFTRONICS

## 10.0 ELEMENTARY DIAGRAM DESCRIPTION (CONTINUED)

COMPONENT	FUNCTION
DC Bus	<p>The DC bus is the "storage and power plant" for the output section. The inverter looks at the DC bus for the under voltage and over voltage trip points.</p> <p>A bad DC bus capacitor can be identified by checking the pressure relief plug, located on the top to the cap between the + and - terminals. If this plug is raised or if a small hole is present, the capacitor is bad. It is recommended to replace all DC bus caps as the others may have been stressed. Ensure replacement caps are properly formed before reapplying power.</p>
DC Bus Fuse	<p>The DC bus fuse is used to protect the inverter not the transistors. A FU fault indicates the DC bus fuse is open and drive will not operate. An open DC fuse indicates that there are output transistors damaged.</p> <p><b>DO NOT REPLACE DC FUSE WITHOUT CHECKING AND REPLACING DAMAGED TRANSISTORS.</b></p> <p>Failure to replace damaged transistors will result in further damage to the inverter.</p>
TRM1-3 Output Transistors IGBT	<p>Definition: Insulated gate Bi-Polar transistors.</p> <p>IGBT's differ from Bi -Polar transistors in two main ways.</p> <ol style="list-style-type: none"> <li>1. The base is insulated from the emitter and collector, resistance from emitter-base or base-collector will read infinite.</li> <li>2. The IGBT is a voltage dependent device unlike a Bi-Polar transistor which is a current dependent device. This allows for much smaller driver circuits and less power consumption.</li> </ol> <p>The IGBT's take the DC bus voltage and chop it into a pulse width modulated (PWM) waveform.</p>
DCCT	<p>DCCT-D.C. Current transformer. When a current is passed through the DCCT's winding a DC voltage is produced. The DCCT's are the current feedback to the inverter.</p> <p>If you are experiencing OL or OC nuisance trips one or more of the DCCT's may be bad.</p> <p><b>DO NOT ATTEMPT TO ADJUST POTS ON DCCT. DAMAGE TO INVERTER MAY RESULT.</b></p>



11.0 ELEMENTARY DIAGRAMS

Typical Elementary Diagram for 230V Series

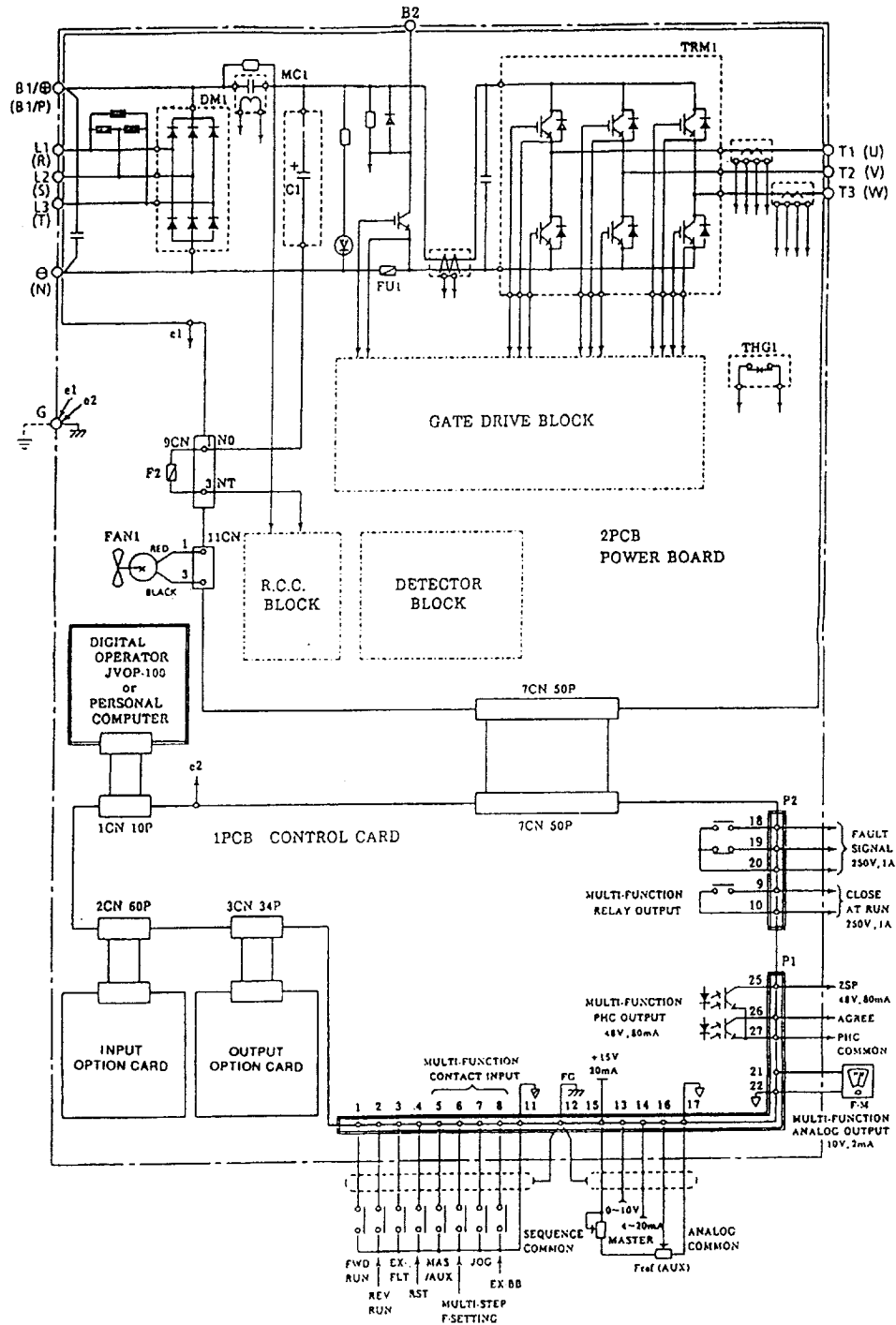

## 11.0 ELEMENTARY DIAGRAMS (CONTINUED)

### Typical Elementary Diagram for 460V Series

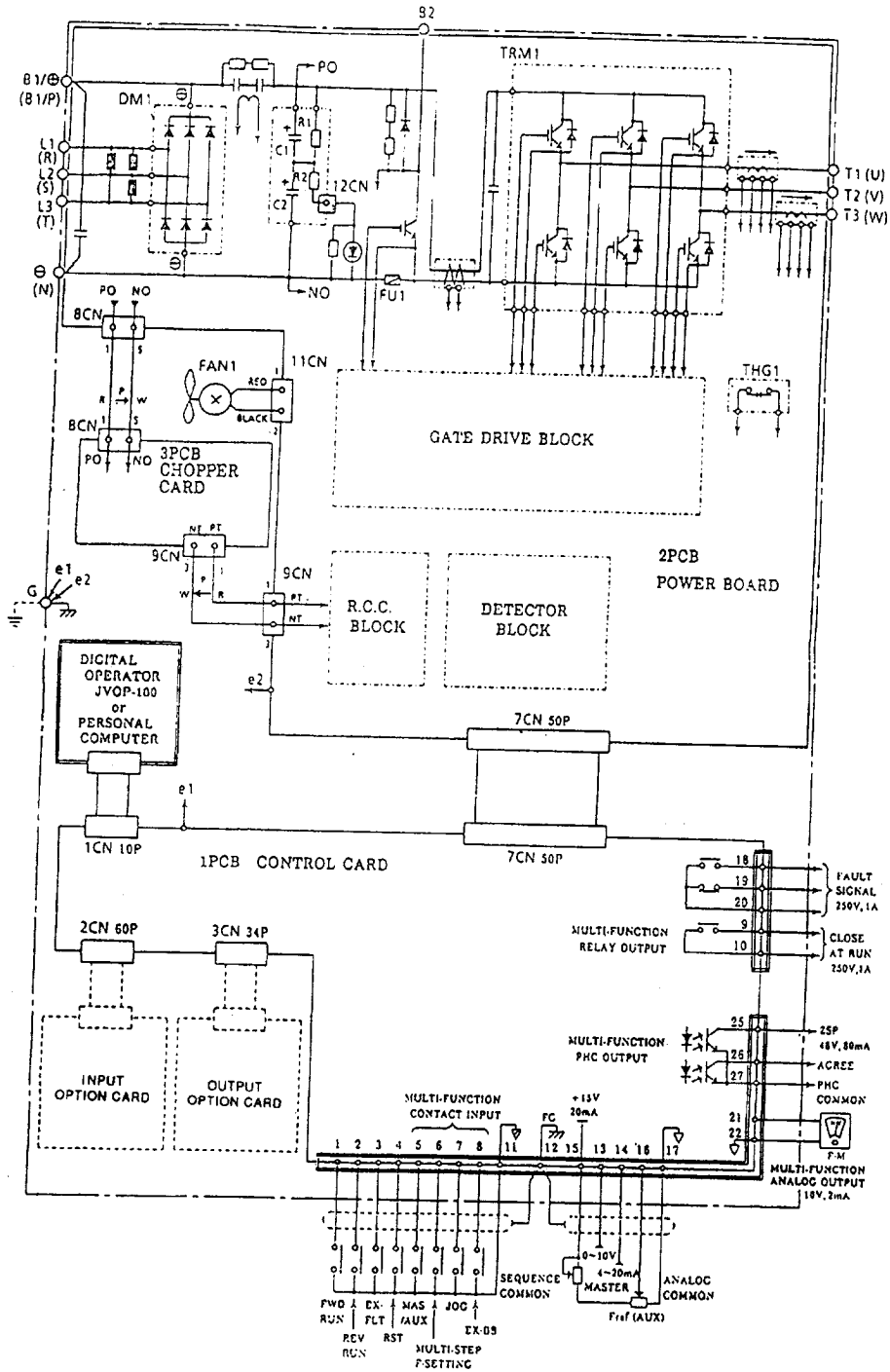

11.0 ELEMENTARY DIAGRAMS (CONTINUED)

Typical Elementary Diagram for 575V Series

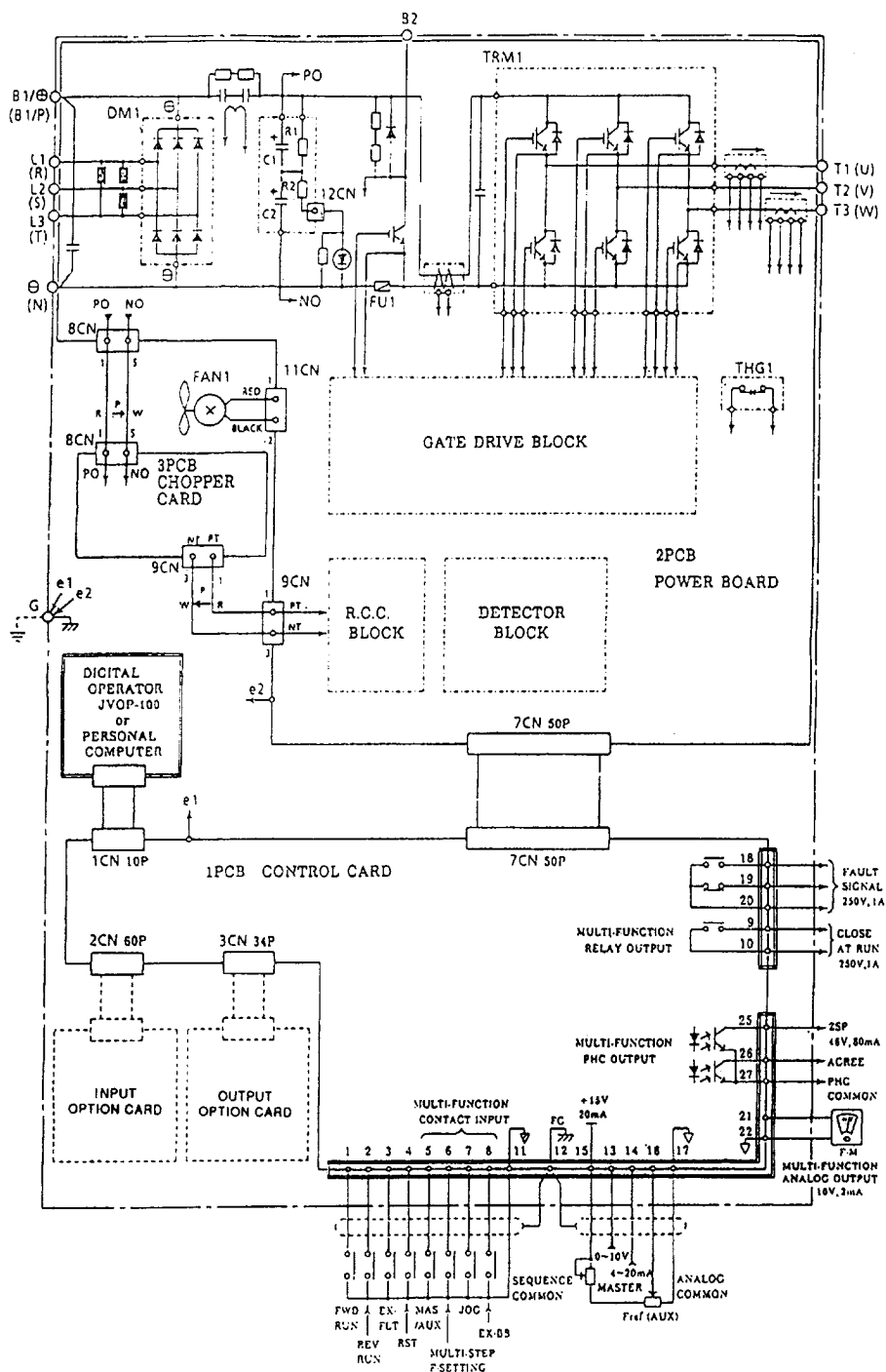

# SAFTRONICS

## 12.0 TROUBLESHOOTING GUIDE

### 1. Main Circuit Checks

- a. Input Diodes (DM1)
- b. DC Bus Fuse (FU1)
- c. Output IGBT (TRM1)
- d. Pre-charge Res. (R1)
- e. IMC Contactor (MC1)
- f. Braking Trans. (BTR)
- g. Cooling Fan (FAN1)

### 2. Board Level Checks

- a. 24VDC Power Supply Checks
- b. 15VDC Power Supply Checks
- c. Gate Signals
- d. PWM Output Waveform
- e. Current Output Waveform

### MAIN CIRCUIT CHECKS

**CAUTION:** Before checking any component in drive, be sure charge lamp is off and input power locked out.

#### A. Input Diode Check

Test Equipment: Ohm Meter to RX1 Scale

Measure resistance between L1, L2, L3 and + - bus.

Diodes should block current in on direction and pass current in other direction.

Models	Positive Point	Negative Point
20P4-27P5	B1/ (+)	(-)
2011-2022	B1/ (+)	B0/ (-)
2030-2075	(+) 1	(-)
40P4-47P5	B1/ (+)	B0/ (-)
4011-4L45	B1/ (+)	B0/ (-)
4055-4300	(+)1	(-)
53P7-5018	B1/ (+)	(-)
5022-5160	B1/ (+)	B0/ (-)

**12.0 TROUBLESHOOTING GUIDE (CONTINUED)**

**Main Circuit Checks (Continued)**

**B. DC Buse Fuse Check**

Test Equipment - Ohm Meter set to RX1 Scale

Locate DC bus Fuse (FU1) and measure across fuse with ohm meter.

**NOTE:** If DC Bus Fuse is open, DO NOT replace until the output transistor has been checked and replaced. When the DC bus fuse is open there is a 99.9% chance there is a bad transistor. Failure to replace transistor will result in further damage to unit.

**C. Output IGBT Modules:**

Test Equipment - Ohm Meter set to RX1 scale

Measure between T1, T2, T3, and + - bus

Models	Positive Point	Negative Point
20P4-27P5	B1/ (+)	(-)
2011-2022	B1/ (+)	B0/ (-)
2030-2075	(+) 1	(-)
40P4-47P5	B1/ (+)	B0/ (-)
4011-4L45	B1/ (+)	B0/ (-)
4055-4300	(+)1	(-)
53P7-5018	B1/ (+)	(-)
5022-5160	B1/ (+)	B0/ (-)

**NOTE:** The IGBT Module will measure the same as a bipolar transistor across collector and emitter. The gate-emitter and gate-collector junction will read infinity. Because the gate is insulated. IGBT (Insulated gate Bi-Polar transistor)

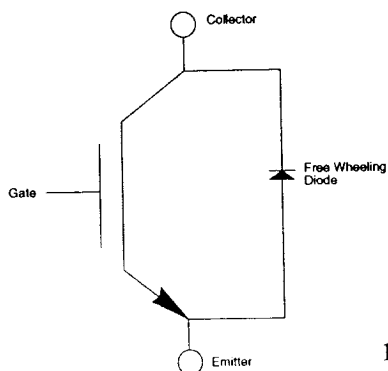

# SAFTRONICS

## 12.0 TROUBLESHOOTING GUIDE (CONTINUED)

### Main Circuit Checks (Continued)

#### D. Pre-Charge Resistor Check

Model No.	RI Location	RI Value
20P4-23P7	Power Board	Low Ohmic Value 1 Ohm - 10 Ohm High Wattage 40W - 220W
25P5-2075	Heatsink of Inverter	
40P4-42P2	Power Board	
43P7-4300	Heatsink of Inverter	
53P7-5160	Heatsink of Inverter	

NOTE: If Pre-Charge resistor is open, proceed to Step E before replacing and Powering Up.

#### E. IMC Contactor Check

Test Equipment - Ohm Meter set to RX1 scale.

Locate IMC and do mechanical check. Make sure there is free movement when actuated by hand. Check for continuity between input and output of all three (3) contacts. Check for loose auxillary contacts (if any).

Model No.	IMC Location	Coil Voltage
20P4-21P5	Power Board	24VDC
22P2-27P5	Heatsink of Inverter	24VDC
2011-2075	Heatsink of Inverter	220VAC
40P4-42P2	Power Board	24VDC
43P7-4015	Heatsink of Inverter	24VDC
4018-4300	Heatsink of Inverter	220VAC
53P7-5018	Heatsink of Inverter	24VDC
5022-5160	Heatsink of Inverter	220VAC

**12.0 TROUBLESHOOTING GUIDE (CONTINUED)**

**Main Circuit Checks (Continued)**

**F. Braking Transistor**

Test Equipment Ohm Meter set to RX1 scale  
Measure across the Emitter and Collector

Model	Location
20P4-27P5	Power Board
2011-2075	Not built-in
40P4-42P2	Power Board
43P7-4015	Heatsink of Inverter
4018-4300	Not built-in
53P7-5018	Heatsink of Inverter
5022-5160	Not built-in

**G. Cooling Fans**

Test Equipment: Ohms Meter set to Rx1 scale  
24VDC Power Supply

Model	Fan Installed	Fan Voltage
20P4-21P5	No	-
22P2-27P5	Yes	24VDC
2011-2075	Yes	220VAC
40P4-47P5	Yes	24VDC
4011-4300	Yes	24VDC
53P7-5160	Yes	220VAC

**NOTE:** For 24VDC fans, connect external 24VDC power supply to fan wires.  
For 220VAC coil, measure with Ohm Meter, look for open or shorted condition.

# SAFTRONICS

## 12.0 TROUBLESHOOTING GUIDE (CONTINUED)

### Main Circuit Checks (Continued)

#### 2. Board Level Checks

##### A. +24VDC Power Supply Checks

Test Equipment: DC Volt Meter

Measure between terminals

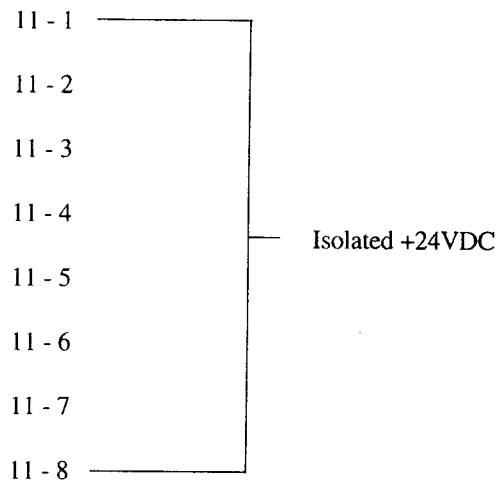

##### B. +15VDC Power Supply Check

Test Equipment: DC Volt Meter

Measure between terminals

15 - 17 = 15VDC

##### C. Gate Signal Checks

Test Equipment: Oscilloscope with X10 Probe

**DANGER!** Use an ungrounded scope for all test!

Beware scope is at High Potential!

Do Not Touch!

Measure across gate-emitter Points



**12.0 TROUBLESHOOTING GUIDE (CONTINUED)**

**Main Circuit Checks Continued**  
Gate Signal Checks continued

Model No.	Gate-Emitter Location
20P4-23P7	Power Board BW-EW / BV-EV / BU-EU
25P5-2022	Power Board 12CN, 13CN, 14CN
2030-2037	Gate Drive Board 12CN, 15CN, 16CN, 17CN
2045-2075	Sub-drive Board 30CN, 31CN, 32CN, 33CN, 34CN, 35CN
40P4-47P5	Power Board BW-EW / BV-EV / BU-EU
4011-4L45	Power Board 11CN, 12CN, 13CN, 14CN
4055-4075	Gate Drive Board 12CN, 15CN, 16CN, 17CN
4110-4160	Sub-drive Board 30CN, 31CN, 32CN, 33CN, 34CN, 35CN
4185-4300	Sub-drive Board (One per phase) 1CN, 2CN
53P7-5055	Power Board 12CN, 15CN, 16CN, 17CN
5075-5160	Sub-drive Board 30CN, 31CN, 32CN, 33CN, 34CN, 35CN

Fig 2

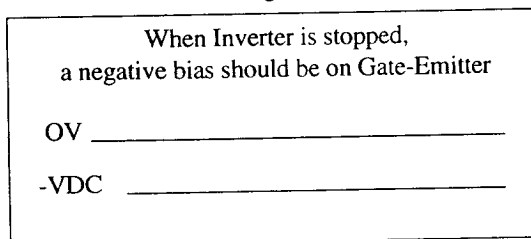
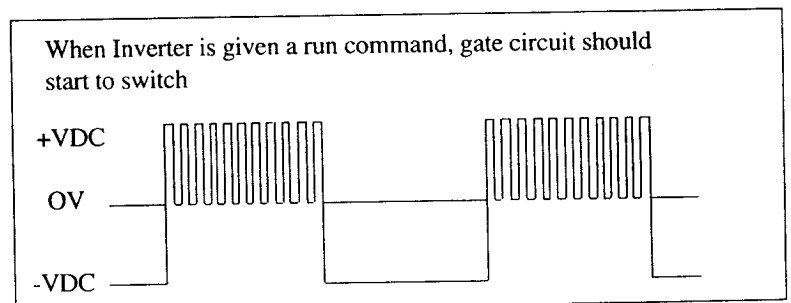

Fig 3



## 12.0 TROUBLESHOOTING GUIDE (CONTINUED)

### Main Circuit Checks Continued

#### D. PWM Waveform Checks

Test Equipment: Oscilloscope with X100 Probe.

**DANGER!** Use an ungrounded scope for all test!  
Beware scope is at high potential!  
Do Not Touch!

Measure between

T1 - T2

T1 - T3

T2 - T3

Run units at 10Hz, 20Hz, 30Hz, & 60Hz

Fig 4

PWM WAVEFORMS

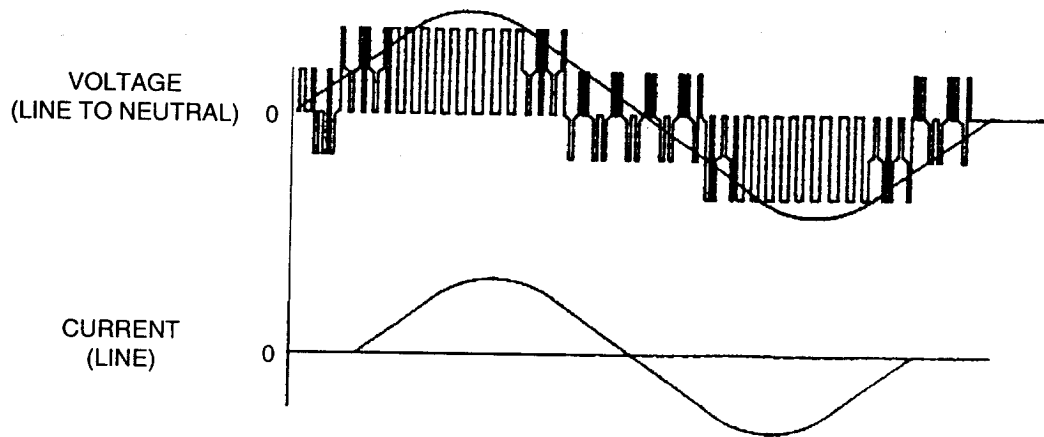

### 13.0 SPARE PARTS LIST

As insurance against costly downtime, it is strongly recommended that renewal parts to be kept on hand in accordance with the table below. When ordering renewal parts, please specify to Safronics Sales or Service Dept. with: Parts Name, Parts NO, and Quantity.

#### Spare Parts for 230V Class

Model	Specifications	Control PC Board	Power Board	Main Circuit Transistor	Main Circuit Diode	DC Bus Fuse	Cooling Fan
20P4	PN	E001056-80	E001067-46	E001057-62	E001067-32	E001067-77	-
	MODEL	ETC61319X-S601X	ETP6U301X	6MB110L-060	10LP44	CR2LS-10/UL	-
	QTY	1	1	1	1	1	-
20P7	PN	E001056-80	E001067-47	E001057-63	E001067-32	E001067-77	-
	MODEL	ETC61319X-S601X	ETP6U302X	6MB115L-060	10L6P44	CR2LS-10/UL	-
	QTY	1	1	1	1	1	-
21P5	PN	E001056-80	E001067-48	E001057-64	E001067-33	E001067-77	-
	MODEL	ETC61319X-S601X	ETP6U323X	6MB120L-060	20L6P44	CR2LS-10/UL	-
	QTY	1	1	1	1	1	-
22P2	PN	E001056-80	E001067-49	E001057-65	E001067-34	E001058-71	E001067-63
	MODEL	ETC61319X-S601X	ETP6U324X	6MB130L-60	6R130E-080	CR2LS-20/UL	4710NL-05W-B40
	QTY	1	1	1	1	1	1
23P7	PN	E001056-80	E001067-50	E001057-66	E001067-34	E001058-72	E001067-63
	MODEL	ETC61319X-S601X	ETP6U325X	6MB150L-60	6R130E-080	CR2LS-30/UL	4710NL-05W-B40
	QTY	1	1	1	1	1	1
25P5	PN	E001067-108	E001067-51	E001067-19	E001067-35	E001058-78	E001067-63
	MODEL	ETC61318X-S601X	ETP61326X	MG75J2YS1	6R150E-080	CR2LS-50/UL	4710NL-05W-B40
	QTY	1	1	3	1	1	1
27P5	PN	E001067-108	E001067-52	E001067-20	E001067-36	E001058-78	E001067-63
	MODEL	ETC61318X-S601X	ETP61327X	MG100J2YS1	6R175E-080	CR2LS-50/UL	4710NL-05W-B40
	QTY	1	1	3	1	1	1
2011	PN	E001067-108	E001067-57	E001067-21	E001067-37	E001058-79	E001058-77 E001067-64
	MODEL	ETC61318X-S601X	ETP61302X	MG150J2YS1	100L6P41	CR2LS-75/UL	5915PC-22T-B30 4710PS-22T-B20-B00
	QTY	1	1	3	1	1	1+1
2015	PN	E001067-108	E001067-57	E001067-22	E001067-38	F602003-09	E001058-77 E001067-64
	MODEL	ETC61318X-S601X	ETC61302X	MG200J2YS1	110L2G43	A50P100	5915PC-22T-B30 4710PS-22T-B20-B00
	QTY	1	1	3	3	1	1+1
2018	PN	E001067-108	E001067-58	E001067-23	E001067-38	F602003-11	E001058-77 E001067-64
	MODEL	ETC61318X-S601X	ETC61303X	CM300HA-12	110L2G43	A50P150	5915PC-22T-B30 4710PS-22T-B20-B00
	QTY	1	1	6	3	1	1+1
2022	PN	E001067-108	E001067-58	E001067-23	E001067-38	F602003-11	E001058-77 E001067-64
	MODEL	ETC61318X-S601X	ETC61303X	CM300HA-12	110L2G43	A50P150	5915PC-22T-B0T 4710PS-22T-B20-B00
	QTY	1	1	6	3	1	1+1

# SAFTRONICS

## SPARE PARTS LIST CONTINUED

### Spare Parts for 230V Class (continued)

Model	Specifications	Control PC Board	Power Board	Main Circuit Transistor	Main Circuit Diode	DC Bus Fuse	Cooling Fan
2030	PN	E001056-75	E001056-81	E001057-47	E001057-73	F602003-13	E001062-74
	MODEL	ETC61320X-S601X	ETC67046X	CM300HA-12E	160L2G43	A50P200	THA1V-U7556MX
	QTY	1	1	6	3	1	2
2037	PN	E001056-75	E001056-82	E001057-68	E001057-73	F602003-16	E001062-74
	MODEL	ETC61320X-S601X	ETC67043X	CM400HA-12E	160L2G43	A50P275	THA1V-U7556MX
	QTY	1	1	6	6	1	2
2045	PN	E001056-75	E001056-83	E001057-69	E001057-73	F602003-20	E001062-74
	MODEL	ETC61320X-S601X	ETC67016X	CM300HA-12E(2P)	160L2G43	A50P400	THA1V-U7556MX
	QTY	1	1	12	6	1	2
2055	PN	E001056-75	E001056-83	E001057-69	E001057-73	F602003-20	E001062-74
	MODEL	ETC61320X-S601X	ETC67016X	CM300HA-12E(2P)	160L2G43	A50P400	THA1V-U7556MX
	QTY	1	1	12	6	1	2
2075	PN	E001056-75	E001056-84	E001057-70	E001057-73	F602003-23	E001062-74
	MODEL	ETC61320X-S601X	ETC67017X	CM400HA-12E(2P)	160L2G43	A50P600	THA1V-U7556MX
	QTY	1	1	12	9	1	2

## SPARE PARTS LIST (CONTINUED)

## Spare Parts for 460V Class

Model	Specifications	Control PC Board	Power Board	Main Circuit Transistor	Main Circuit Diode	DC Bus Fuse	Cooling Fan	Chopper PC Board(1)
40P4	PN	E001067-108	E001056-85	E001067-24	E001067-39	E00106-78	E001067-63	E001067-62
	MODEL	ETC61318X-S601X	ETP6U342X	6MB18-120	RM10TA-24	A70P15	4710NL-05W-B40	ETC61304X
	QTY	1	1	1	1	1	1	1
40P7	PN	E001067-108	E001056-85	E001067-24	E001067-39	E001067-78	E001067-63	E001067-62
	MODEL	ETC61318X-S601X	ETP6U342X	6MB18-120	RM10TA-24	A70P15	4710NL-05W-B40	ETC61304X
	QTY	1	1	1	1	1	1	1
41P5	PN	E001067-108	E001056-86	E001067-25	E001067-39	E001067-78	E001067-63	E001067-62
	MODEL	ETC61318X-S601X	ETP6U343X	6MB115-120	RM10TA-24	A70P15	4710NL-05W-B40	ETC61304X
	QTY	1	1	1	1	1	1	1
42P2	PN	E001067-4108	E001056-86	E001067-25	E001067-39	E001067-78	E001067-63	E001067-62
	MODEL	ETC61318X-S601X	ETP6U343X	6MB115-120	RM10TA-24	A70P15	4710NL-05W-B40	ETC61304X
	QTY	1	1	1	1	1	1	1
43P7	PN	E001067-108	E001056-87	E001067-26	E001067-40	E001067-79	E001067-63	E001067-62
	MODEL	ETC61318X-S601X	ETP6U344X	2MB125-120	30Q6P42	A70P30	4710NL-05W-B40	ETC61304X
	QTY	1	1	3	1	1	1	1
45P5	PN	E001067-108	E001056-88	E001067-27	E001067-40	E001067-79	E001067-63	E001067-62
	MODEL	ETC61318X-S601X	ETP6U345X	2MB150-120	30Q6P42	A70P30	4710NL-05W-B40	ETC61304X
	QTY	1	1	3	1	1	1	1
47P5	PN	E001067-108	E001056-88	E001067-27	E001067-40	E001067-79	E001067-63	E001067-62
	MODEL	ETC61318X-S601X	ETP6U345X	2MB150-120	30Q6P42	A70P30	4710NL-05W-B40	ETC61304X
	QTY	1	1	3	1	1	1	1
4011	PN	E001067-108	E001067-59	E001067-28	E001067-41	E001058-11	E001067-65 E001058-75	E001067-62
	MODEL	ETC61318X-S601X	ETC61305X	MG75Q2YS1	50Q6P43	A70P50	UHS4556M 4715PS-22T-B30-B00	ETC61304X
	QTY	1	1	3	1	1	1+1	1
4015	PN	E001067-108	E001067-59	E001067-29	E001067-42	E001058-11	E001067-65 E001058-75	E001067-62
	MODEL	ETC61318X-S601X	ETC61305X	MG100Q2YS1	75Q6P43	A70P50	UHS4556M 4715PS-22T-B30-B00	ETC61304X
	QTY	1	1	3	1	1	1+1	1
4018	PN	E001067-108	E001067-60	E001067-30	E001067-43	E001067-80	E001058-77 E001058-75	-
	MODEL	ETC61318X-S601X	ETC61306X	MG150Q2YS1	100Q6P43	A70P100	5915PC-22T-B30-B00 4715PS-22T-B30-B00	-
	QTY	1	1	3	1	1	1+1	-
4022	PN	E001067-108	E001067-60	E001067-30	E001067-43	E001067-80	E001058-77 E001058-75	-
	MODEL	ETC61318X-S601X	ETC61306X	MG150Q2YS1	100Q6P43	A70P100	5915PC-22T-B30-B00 4715PS-22T-B30-B00	-
	QTY	1	1	3	1	1	1+1	-
4030	PN	E001067-108	E001067-61	E001067-31	E001067-44	F602004-14	E001058-77 E001058-75	-
	MODEL	ETC61318X-S601X	ETC61308X	CM300HA-24	110Q2G43	A70P125	5915PC-22T-B30-B00 4715PS-22T-B30-B00	-
	QTY	1	1	6	3	1	1+1	-
4037	PN	E001067-4108	E001067-61	E001067-31	E001067-44	F602004-15	E001058-77 E001058-75	-
	MODEL	ETC61318X-S601X	ETC61308X	CM300HA-24	110Q2G43	A70P150	5915PC-22T-B30-B00 4715PS-22T-B30-B00	-
	QTY	1	1	6	3	1	1+1	-
4045	PN	E001067-108	E001067-61	E001067-31	E001067-44	F602004-15	E001058-77 E001058-75	-
	MODEL	ETC61318X-S601X	ETC61308X	CM300HA-24	110Q2G43	A70P150	5915PC-22T-B30-B00 4715PS-22T-B30-B00	-
	QTY	1	1	6	3	1	1+1	-
4L45	PN	E001067-108	E001056-60	E001067-82	E001067-44	F602004-15	E001058-77 E001058-75	-
	MODEL	ETC61318X-S601X	ETC61312X	CM400HA-24	110Q2G43	A70P150	5915PC-22T-B30-B00 4715PS-22T-B30-B00	-
	QTY	1	1	6	3	1	1+1	-

Notes: (1) Code 'F' and higher units do not have a Chopper PC Board.

# SAFTRONICS

## SPARE PARTS LIST (CONTINUED)

### Spare Parts for 460V Class (continued)

Model	Specifications	Control PC Board	Power Board	Main Circuit Transistor	Main Circuit Diode	DC Bus	Cooling Fan
4055	PN	E001056-75	E001056-61	E001067-82	E001057-34	E001060-44	E001062-74
	MODEL	ETC61320X-S601X	ETC67030X	CM400HA-24	160Q2G43	CR6L-200/UL	THA1V-U7556MX
	QTY	1	1	6	6	1	2
4075	PN	E001056-75	E001056-65	E001067-82	E001057-34	E001060-45	E001062-74
	MODEL	ETC61320X-S601X	ETC67031X	CM400HA-24	160Q2G43	CR6L-300/UL	THA1V-U7556MX
	QTY	1	1	6	6	1	2
4110	PN	E001056-75	E001056-68	E001057-71	E001057-34	F602004-21	E001062-74
	MODEL	ETC61320X-S601X	ETC67035X	CM300HA-24E(2P)	160Q2G43	A70P350	THA1V-U7556MX
	QTY	1	1	12	9	1	2
4160	PN	E001056-75	E001056-64	E001057-72	E001057-06	F602004-25	E001062-74
	MODEL	ETC61320X-S601X	ETC67039X	CM400HA-24E(2P)	RM250DZ-24	A70P600	THA1V-U7556MX
	QTY	1	1	12	6	1	2
4185	PN	E001074-18	E001056-96		E001057-06		E001062-95
	MODEL	ETC61601X-S0031	ETC67037X		RM250DZ-24		EUX350X
	QTY	1	1	(1)	6	(1)	3
4220	PN	E001074-18	E001056-96		E001057-06		E001062-95
	MODEL	ETC61601X-S0031	ETC67037X		RM250DZ-24		EUX350X
	QTY	1	1	(1)	6	(1)	3
4300	PN	E001074-18	E001056-97		E001057-06		E001062-95
	MODEL	ETC61601X-S0031	ETC67041X		RM250DZ-24		EUX350X
	QTY	1	1	(1)	9	(1)	3

Notes: (1) consult factory.

## SPARE PARTS LIST (CONTINUED)

## Spare Parts for 575V Class

Model	Specifications	Control PC Board	Power Board	Main Circuit Transistor	Main Circuit Diode	DC Bus	Cooling Fan
53P7	PN	E001067-108	E001056-77	E001057-56	E001057-57	F602005-05	E001058-75
	MODEL	ETC61318X-S601X	ETC61314X	CM25DY-28	30U6P42	A100P35	4715PS-22T-B30-B00
	QTY	1	1	3	1	1	1
55P5	PN	E001067-108	E001056-78	E001057-58	E001057-57	F602005-05	E001058-77
	MODEL	ETC61318X-S601X	ETC61315X	CM50DY-28	30U6P42	A100P35	5915PC-22T-B30-B00
	QTY	1	1	3	1	1	1
57P5	PN	E001067-108	E001056-78	E001057-58	E001057-57	F602005-05	E001058-77
	MODEL	ETC61318X-S601X	ETC61315X	CM50DY-28	30U6P42	A100P35	5915PC-22T-B30-B00
	QTY	1	1	3	1	1	1
5011	PN	E001067-108	E001056-71	E001057-59	E001057-75	F602005-07	E001058-77
	MODEL	ETC61318X-S601X	ETC61316X	CM100DY-28	75U6P43	A100P50	5915PC-22T-B30-B00
	QTY	1	1	3	1	1	1
5015	PN	E001067-108	E001056-71	E001057-59	E001057-75	F602005-07	E001058-77
	MODEL	ETC61318X-S601X	ETC61316X	CM100DY-28	75U6P43	A100P50	5915PC-22T-B30-B00
	QTY	1	1	3	1	1	1
5018	PN	E001067-108	E001056-71	E001057-59	E001057-75	F602005-07	E001058-77
	MODEL	ETC61318X-S601X	ETC61316X	CM100DY-28	75U6P43	A100P50	5915PC-22T-B30-B00
	QTY	1	1	3	1	1	1
5022	PN	E001056-75	E001056-72	E001057-53	E001057-54	F602005-09	E001062-74
	MODEL	ETC61320X-S601X	ETC61303X	CM200HA-28	110U2G43	A100P100	THA1V-U7556MX
	QTY	1	1	6	3	1	2
5030	PN	E001056-75	E001056-72	E001057-53	E001057-54	F602005-09	E001062-74
	MODEL	ETC61320X-S601X	ETC61603X	CM200HA-28	110U2G43	A100P100	THA1V-U7556MX
	QTY	1	1	6	3	1	2
5037	PN	E001056-75	E001056-72	E001057-53	E001057-54	F602005-09	E001062-74
	MODEL	ETC61320X-S601X	ETC61603X	CM200HA-28	110U2G43	A100P100	THA1V-U7556MX
	QTY	1	1	6	3	1	2
5045	PN	E001056-75	E001056-72	E001057-60	E001057-54	F602005-10	E001062-74
	MODEL	ETC61320X-S601X	ETC61603X	CM300HA-28	110U2G43	A100P150	THA1V-U7556MX
	QTY	1	1	6	3	1	2
5055	PN	E001056-75	E001056-72	E001057-60	E001057-54	F602005-10	E001062-74
	MODEL	ETC61320X-S601X	ETC61603X	CM300HA-28	110U2G43	A100P150	THA1V-U7556MX
	QTY	1	1	6	3	1	2
5075	PN	E001056-75	E001056-79	E001057-61	E001057-54	F602005-11	E001062-74
	MODEL	ETC61320X-S601X	ETC61607X	CM200HA-28(2P)	110U2G43	A100P200	THA1V-U7556MX
	QTY	1	1	12	6	1	2
5090	PN	E001056-75	E001056-79	E001057-61	E001057-54	F602005-11	E001062-74
	MODEL	ETC61320X-S601X	ETC61607X	CM200HA-28(2P)	110U2G43	A100P200	THA1V-U7556MX
	QTY	1	1	12	6	1	2
5110	PN						
	MODEL						
	QTY	(1)	(1)	(1)	(1)	(1)	(1)
5160	PN						
	MODEL						
	QTY	(1)	(1)	(1)	(1)	(1)	(1)

Notes: (1) Consult factory.

# SAFTRONICS

---

---

## 14.0 WARRANTY

---

Saftronics warrants to buyer that products, and any services furnished hereunder will be free from defects in material, workmanship and title, and will be of the kind and quality specified in the quotation. The foregoing shall apply only to failures to meet said warranties (excluding any defects in title) which appear within one year from the date of shipment hereunder, provided, however, that if buyer, in the course of its regular and usual business, transfers title to or leases such products (including equipment incorporating such products) to a third party, such period shall run until one year from such transfer or lease or eighteen months from shipment by Saftronics whichever occurs first. The warranties and remedies set forth here in are conditioned upon (a) proper storage, installation, use and maintenance, and conformance with any applicable recommendations of Saftronics and, (b) buyer promptly notifying Saftronics of any defects and, if required, promptly making the product available for correction.

If any products or services fails to meet the foregoing warranties (except title), Saftronics shall thereupon correct any such failure either, at its option, (i) by repairing any defective or damaged part or parts of the products, or (ii) by making available FOB Saftronics plant or other point of shipment, any necessary repaired or replacement parts. The preceding paragraph sets forth the exclusive remedies for claims (except as to title) based on defect in or failure of products or services, whether claim in contract or tort (including negligence) and however instituted. Upon expiration of the warranty period, all such liability shall terminate. The foregoing warranties are exclusive and in lieu of all other warranties, whether written, oral, implied or statutory. No implied statutory warranty of merchantability or fitness for particular purpose shall apply and Saftronics will not be liable for any consequential damage arising from any product defect or failure to deliver on time. Saftronics does not warrant any products or services of others which buyer has designated.