

YASNAC J50 CONNECTING MANUAL

CNC SYSTEM FOR MACHINE TOOLS

BEFORE INITIAL OPERATION, READ THESE INSTRUCTIONS THOROUGHLY, AND
RETAIN FOR FUTURE REFERENCE.



This manual describes the specifications for connecting YASNAC J50 Series with machines, machine interfaces and external equipment.

Necessary connections to be provided by the machine builder differ depending on the type of the CNC unit supplied by Yaskawa. Make additions or deletions of connections in accordance with the combination for standard cabinets and integrated units.

The programmable controller system (hereafter called PC) is installed in the YASNAC J50 CNC unit. For details of the PC, refer to instruction Manual for YASNAC J50 PC System (SIE-C843-12.1).



94-C84-123

YASNAC J50 Operator's Panel

CONTENTS

	Page
1. CONFIGURATION	1
1.1 SYSTEM CONFIGURATION	1
1.2 STANDARD CABINETS AND INTEGRATED UNITS	1
2. ENVIRONMENTAL CONDITIONS	1
3. CABINET CONSTRUCTION DESIGN	1
4. CABINET DESIGN FOR HEAT FACTORS	3
4.1 SELECTION OF HEAT EXCHANGER	3
4.2 HEAT VALUES OF UNITS	3
4.3 DUST-PROOF CONSTRUCTION	4
4.4 PROTECTION FROM MAGNETIC INFLUENCES	5
5. PRECAUTIONS FOR INSTALLING SERVO UNIT	6
6. CABLE ENTRANCE	7
6.1 LAYOUT OF CABLE CONNECTORS	7
6.2 CLAMPING CABLES AND SHIELDING CABLES	8
6.3 CONNECTING DIAGRAMS	9
7. POWER SUPPLY CONNECTION	12
7.1 POWER SUPPLY CONNECTION TO EACH UNIT	12
7.2 DETAILS OF CONNECTION	12
8. CONNECTION TO OPERATOR'S PANEL	13
8.1 CONNECTION TO EACH UNIT	13
8.2 DETAILS OF CONNECTION	14
9. CONNECTION OF MANUAL PULSE GENERATOR	15
9.1 CONNECTION TO EACH UNIT	15
9.2 DETAILS OF CONNECTION	16
10. CONNECTION OF INPUT SEQUENCE	16
10.1 CONNECTION TO EACH UNIT	16
10.2 DETAILS OF CONNECTION	17
10.3 DETAILS OF SIGNALS	19
11. CONNECTION TO FEED SERVO UNITS	20
11.1 CONNECTION TO EACH UNIT	20
11.2 DETAILS OF CONNECTION	22
12. CONNECTION TO SPINDLE DRIVE UNIT	29
12.1 CONNECTION TO EACH UNIT	29
12.2 DETAILS OF CONNECTION	34
12.3 CABLE SPECIFICATIONS	40
13. CONNECTION TO TAPE READER	41
13.1 CONNECTION TO EACH UNIT	41
13.2 DETAILS OF CONNECTION	41
14. CONNECTION TO RS-232C INTERFACE	42
14.1 CONNECTION TO EACH UNIT	42
14.2 DETAILS OF CONNECTION	42
14.3 RS-232C INTERFACE	43

	Page
15. DIRECT-IN SIGNAL CONNECTION	45
15.1 CONNECTION TO EACH UNIT	45
15.2 DETAILS OF CONNECTION	45
15.3 DETAILS OF SIGNALS	46
16. CONNECTION TO GENERAL-PURPOSE I/O SIGNALS	47
16.1 CONNECTION TO EACH UNIT	47
16.2 DETAILS OF CONNECTION	47
16.3 CONNECTION TO ADDITIONAL GENERAL-PURPOSE I/O SIGNALS	48
16.4 DETAILS OF CONNECTION	48
17. CONNECTION TO GENERAL-PURPOSE I/O	50
17.1 CONNECTION TO EACH UNIT	50
17.2 DETAILS OF CONNECTION	51
17.3 EXPLANATION OF GENERAL-PURPOSE I/O SIGNALS	85
18. CABLES	89
18.1 LIST OF CABLES	89
18.2 SPECIFICATIONS OF CABLE	91
18.3 LIST OF CONNECTORS	93
18.4 SHORTING PIN SETUPS	98
19. J50L STANDARD I/O SIGNALS	99
19.1 LIST OF NC STANDARD I/O SIGNALS	99
19.2 DETAILS OF SIGNALS	105
20. J50M STANDARD I/O SIGNALS	130
20.1 LIST OF NC STANDARD I/O SIGNALS	130
20.2 DETAILS OF SIGNALS	138
APPENDIX A DIMENSIONS in mm	163
APPENDIX B I/O PORT ADDRESS SETTING	171
APPENDIX C STANDARD WIRING COLORS OF YASNAC	174

1. CONFIGURATION

1.1 SYSTEM CONFIGURATION

The system configuration of YASNAC J50 is shown below.

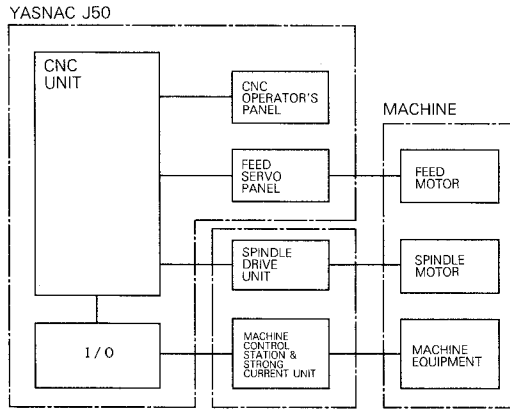

Fig. 1.1 System Configuration of YASNAC J50

2. ENVIRONMENTAL CONDITIONS

The following conditions are for locations where the control panel is installed by the machine builder. Therefore, follow Par. 4 "CABINET CONSTRUCTION DESIGN" in the design process so that these conditions will be satisfied.

(1) Ambient Temperature

During operation: 0 to 45

During storage or transport: -20 to +60

Even if ambient temperature is less than 45, do not install the control panel under direct sunlight, near a heating element or outdoor.

(2) Relative Humidity: 10 to 90 % (Non-condensing)

(3) Vibration: 4.9m/s² or less during operation

(4) Atmosphere: Do not use the control panel under environment with a lot of dust and dirt or with high density of coolant or organic solvent.

3. CABINET CONSTRUCTION DESIGN

Take the following into consideration when cabinets to contain the CNC unit and other units are designed.

(1) Make sure that the cabinets are of a totally-enclosed type. The feed servo unit and spindle drive unit can be open type cabinets provided the following considerations are made:

- (a) An air filter is provided at the external air inlet.
- (b) Forced air used in the inside is not blown directly on the units. Direct blowing of air may cause oil mist or dust to settle on the units and might cause failures.
- (c) The air discharge outlet should be positioned where dust and oil mist do not enter. The heat sink of the feed servo and spindle drive units can be installed outside for higher thermal efficiency. The cabinets should be of a totally-enclosed type to improve reliability.

(2) Design the cabinet so that the difference between the inner-air temperature and ambient temperature is less than 10°C. Read Par. 4 for cabinet design to accommodate heat.

(3) Install a fan inside totally-enclosed cabinets to improve the internal cooling efficiency and to prevent localized temperature increases by circulating air inside the cabinets.

The velocity of the circulating air should be greater than 2 m/s on the surfaces of the printed circuit boards. Forced air should not blow directly on the printed circuit boards.

(4) Provide spacing of more than 100 mm between components and cabinet walls for smooth flow of air.

(5) Seal the cable openings, doors, etc. completely. The CNC operator's panel operates at a particularly high voltage and collects dust in the air. Special caution is needed.

The cabinet for mounting the CNC operator's panel requires the following precautions:

- (a) Use packing material on the mounting surface to eliminate gaps.
- (b) Use packing material in the cable openings and doors.

(6) Magnetic Deflection of CRT Display

CRT displays are sometimes deflected due to external magnetic influences. Sources that generate magnetic fields, such as transformers, reactors, fans, solenoid switches and relays, and AC power cables should be positioned more than 300 mm from the CNC operator's panel. This distance is optimum and may vary for each circumstance. Determine the component layout beforehand.

3. CABINET CONSTRUCTION DESIGN (Cont'd)

- (7) To prevent malfunction due to noise, mount the units more than 100 mm from cables feeding 90 VDC or greater, AC power lines, and other components. The following precautions should be complied with during wiring:
 - (a) Separate AC and DC cables.
 - (b) Separate the primary and secondary sides of transformers, line filters, etc.
- (8) The front panels of the units that are exposed to the cabinet surfaces, such as the CNC operator's panel, tape reader, and PO unit should be of a dustproof type. However, do not install them in locations where cutting fluid may directly splash on them. Be sure to seal completely around the mounting sections.
- (9) Mount the units so as to allow easy checking, removal and reinstalling during maintenance work.
- (10) Read the instruction manuals of the feed servo and spindle drive units when mounting them. Heat sink should be installed outside the cabinet to reduce internal thermal losses. This increases the possibilities for a change from an open type to a totally-enclosed type and reduces the capacity of the heat exchanger.

- (b) Provide spacing of more than 50 mm in the upper section and 100 mm in the lower section of the unit for better ventilation and easier maintenance.
- (c) For ventilation or maintenance, provide spacing more than 50 mm from the upper side and more than 100 mm from the lower side of the CNC unit.

• Example

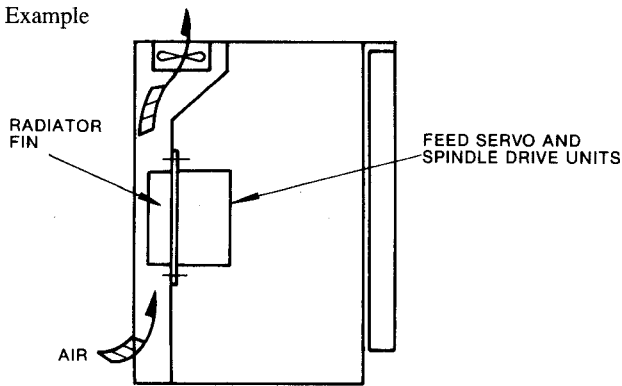

- (11) Precautions for Mounting CNC Unit
 - Observe the following points particularly during mounting of the CNC Unit:
 - (a) Mount the unit in the direction shown in Fig. 3.1.

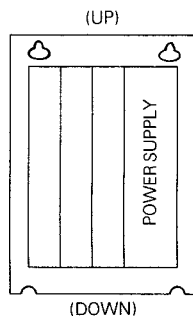

Fig. 3.1 Mounting of CNC Units

4.3 DUST-PROOF CONSTRUCTION

Particles floating in the air (dust, cuttings, oil mist, etc.) may cause malfunction of the CNC unit and the inner parts of the other boards (particularly CRT) to be mounted inside the cabinets the machine manufacturers design and build. The construction of the cabinets, therefore, should be such that it does not allow dust, etc. to enter inside.

- (1) The cabinets should be of totally-enclosed construction.
- (2) Seal the cable openings with packing. (See Fig. 4.1.)
- (3) The door and the back cover should be securely sealed with packing. (See Fig. 4. 2.)
- (4) Special caution is required for the CNC operator's panel as it operates at high voltage and collects dust in the air. The following points should be observed with regard to the pendant box used to install the CNC unit.
 - (a) Seal the cable openings, door, back cover, etc. with packing to eliminate gap.
 - (b) Packing is attached on the surface where the CNC operator's panel is to be mounted. Use the pendant box as it is.
- (5) Seal all gaps.
- (6) Oil mist easily settles on the ceiling and enters the cabinets through screw holes. Special precaution, therefore, should be made using oil-proof packing, etc.

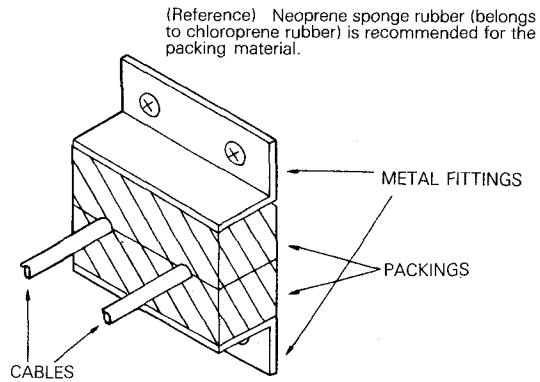

Fig. 4.1 Cable Entrance

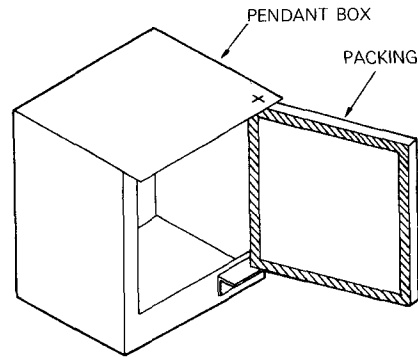

Fig. 4.2 Door Packing

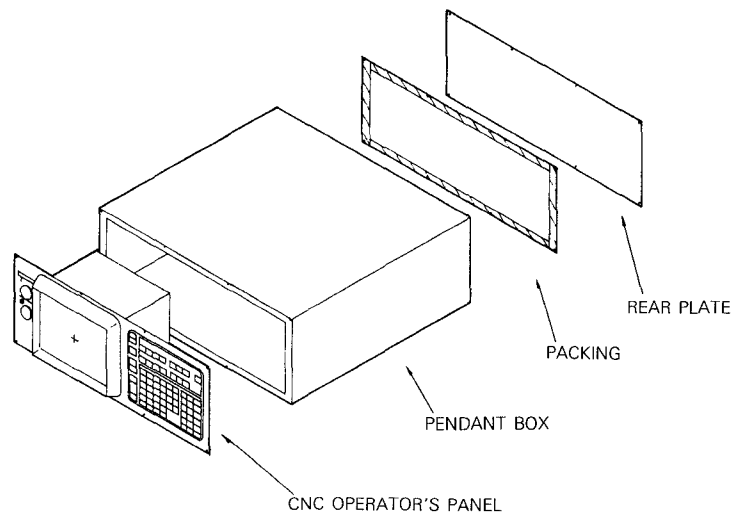

Fig. 4.3 CNC Operation's Panel

4.4 PROTECTION FROM MAGNETIC INFLUENCES

The CRT display may be deflected due to external magnetic influences. Sources that generate magnetic fields (such as transformers, reactors, fans, electromagnetic switches, solenoid relays, AC power cables) should be kept about 300 mm away from the CRT display.

This distance of 300 mm is a rule of thumb and the optimal distance may differ for each setting. Therefore, full precaution should be given to location of the above components that generate magnetic fields and determine the final layout after checking the condition of the CRT display.

5. PRECAUTIONS FOR INSTALLING SERVO UNIT

- (1) The servo unit is a wall-mounted type and should be secured with screws or bolts vertically (so that the printed circuit boards can be seen from the front). (See Fig. 5.1.)
- (2) Mount the servo unit so as to allow easy checking, removal and reinstalling during maintenance work.
- (3) The servo unit generates some amount of heat. Allow for some space in the upper and lower sides when mounting other units and components so that heat will not saturate the inside the unit. (See Fig. 5.2.)
- (4) Expose the radiator fin outside the cabinet and allow the outside air to blow on it to reduce internal thermal loss. (See Fig. 5.1.)
This will help reduce the capacity of the heat exchanger even when it is required.
- (5) When circulating air inside the cabinet, do not allow forced air to blow directly on the servo unit (to prevent dust from collecting on the unit).
- (6) The regenerative resistor generates heat. Full precautions should be given to location of the regenerative resistor and do not place it near components easily affected by heat because a high temperature develops with extremely high frequency in use such as rapid traverse, start and stop.
- (7) Clamp the detector (P.G) cable that enters the servo unit to the ground plate inside the cabinet with the cable clamping fixtures. (See Clamping Cables and Grounding Cable Shield described in Par. 6.2.) Make sure to clamp the cable because it is necessary to operate the system properly and to protect it from malfunctioning due to noise.

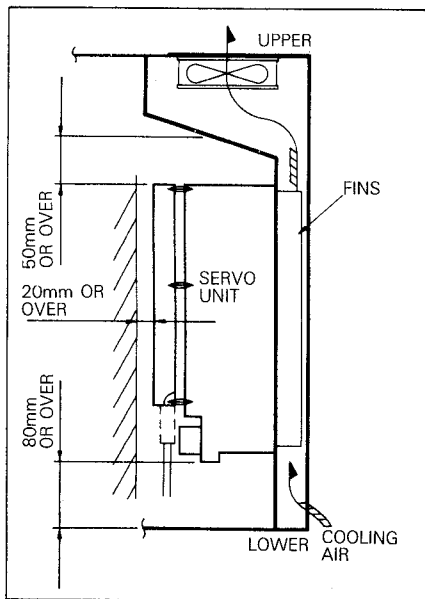

Fig. 5.1 Mounting of Servo Unit (Side View)

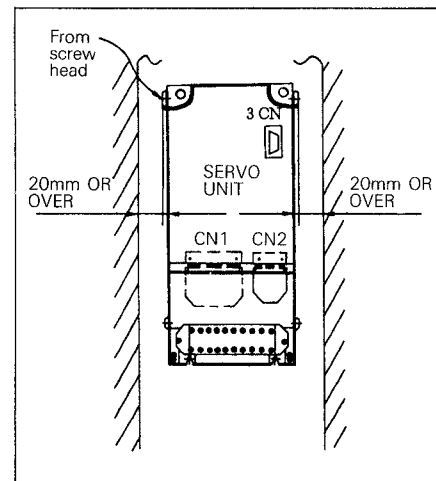

Fig. 5.2 Mounting of Servo Unit (Front View)

6. CABLE ENTRANCE

6.1 LAYOUT OF CABLE CONNECTORS

CNC UNIT TYPE JZNC-JRK00

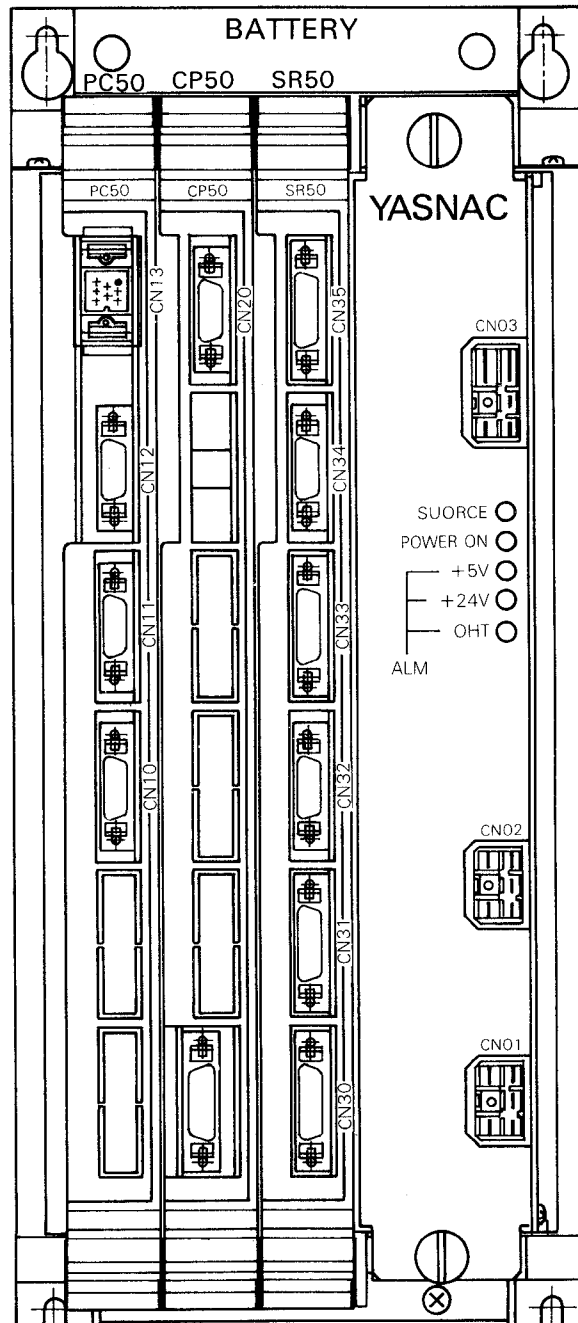

Fig. 6.1 Layout of CNC Unit Connectors

6.2 CLAMPING CABLES AND SHIELDING CABLES

Of the cables connected to the YASNAC, clamp those that need shielding to the ground plate securely with the cable clamping fixtures as shown in the figure below. This clamping serves not only as cable support but also as cable shielding. In ensuring safe operation of the system, it is extremely important that you clamp the necessary cables without fail.

- (a) Strip part of the cable shield as shown in the figure below to expose the shield enclosure.
Press the exposed part onto the ground plate using the cable clamp.
- (b) Mount the ground plate near the cable opening.
- (c) Stripping cable enclosure is not required for non-shielded cables for clamping.

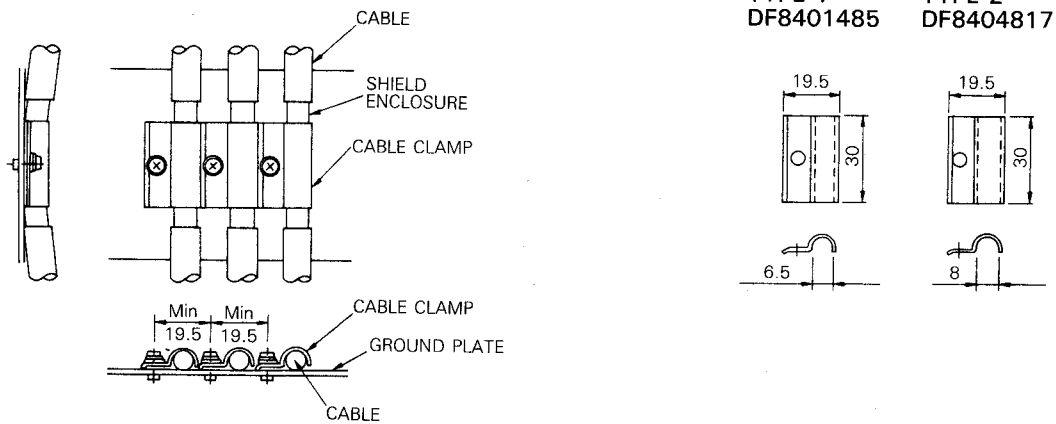

Fig. 6.2 Shielding Cables

6.3 CONNECTING DIAGRAMS

(1) YASNAC J50L (For Lathe)

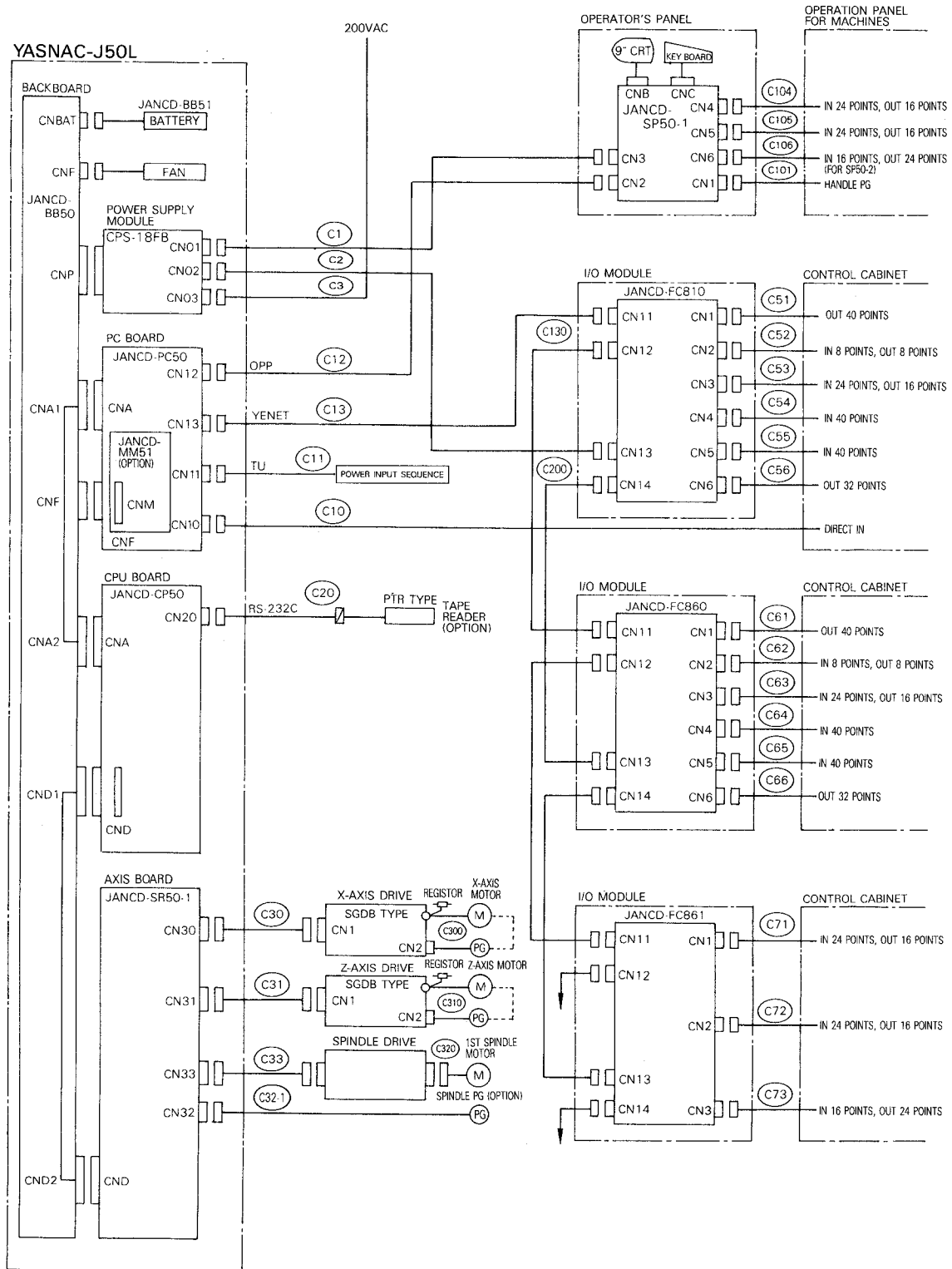

Fig. 6.3

(2) YASNAC J50L (For Multi-axis Lathe)

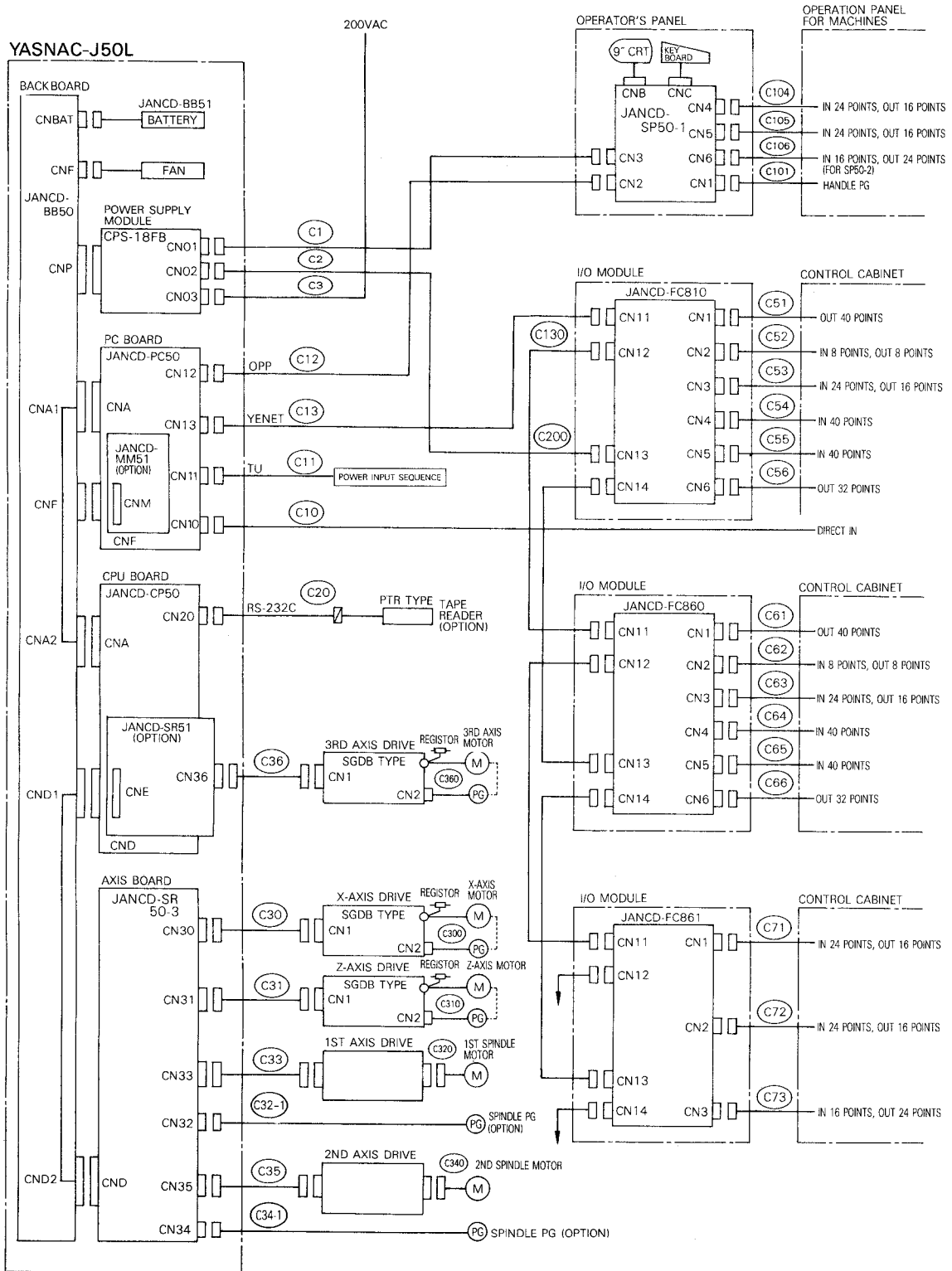

Fig. 6.4

(3) YASNAC J50M (For Machining Centers)

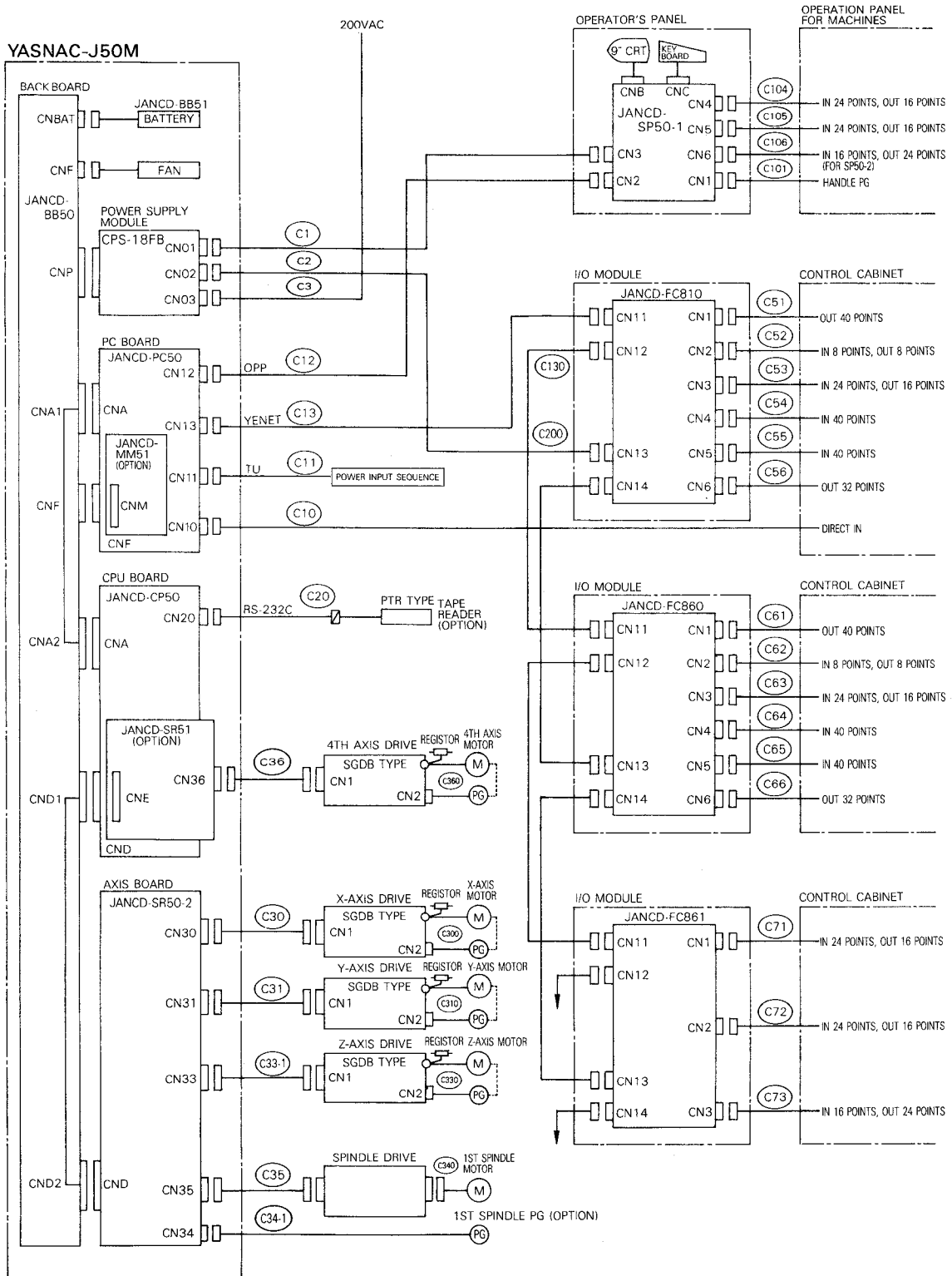

Fig. 6.5

7. POWER SUPPLY CONNECTION

7.1 POWER SUPPLY CONNECTION TO EACH UNIT

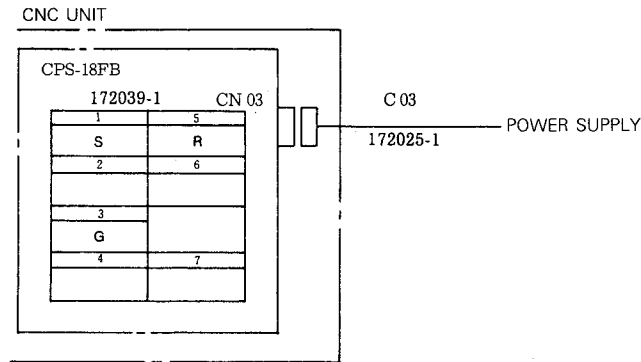
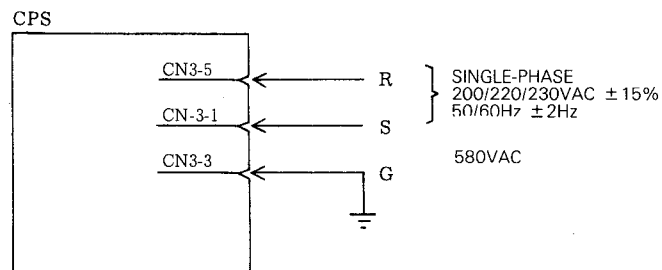

Fig. 7.1

7.2 DETAILS OF CONNECTION



NOTE: The power supply is designed to function normally even in the event of 1/2-cycle or shorter momentary power loss or 1-cycle or shorter 50% voltage drop.

Fig. 7.2 Power Supply Connection

8. CONNECTION TO OPERATOR'S PANEL

8.1 CONNECTION TO EACH UNIT

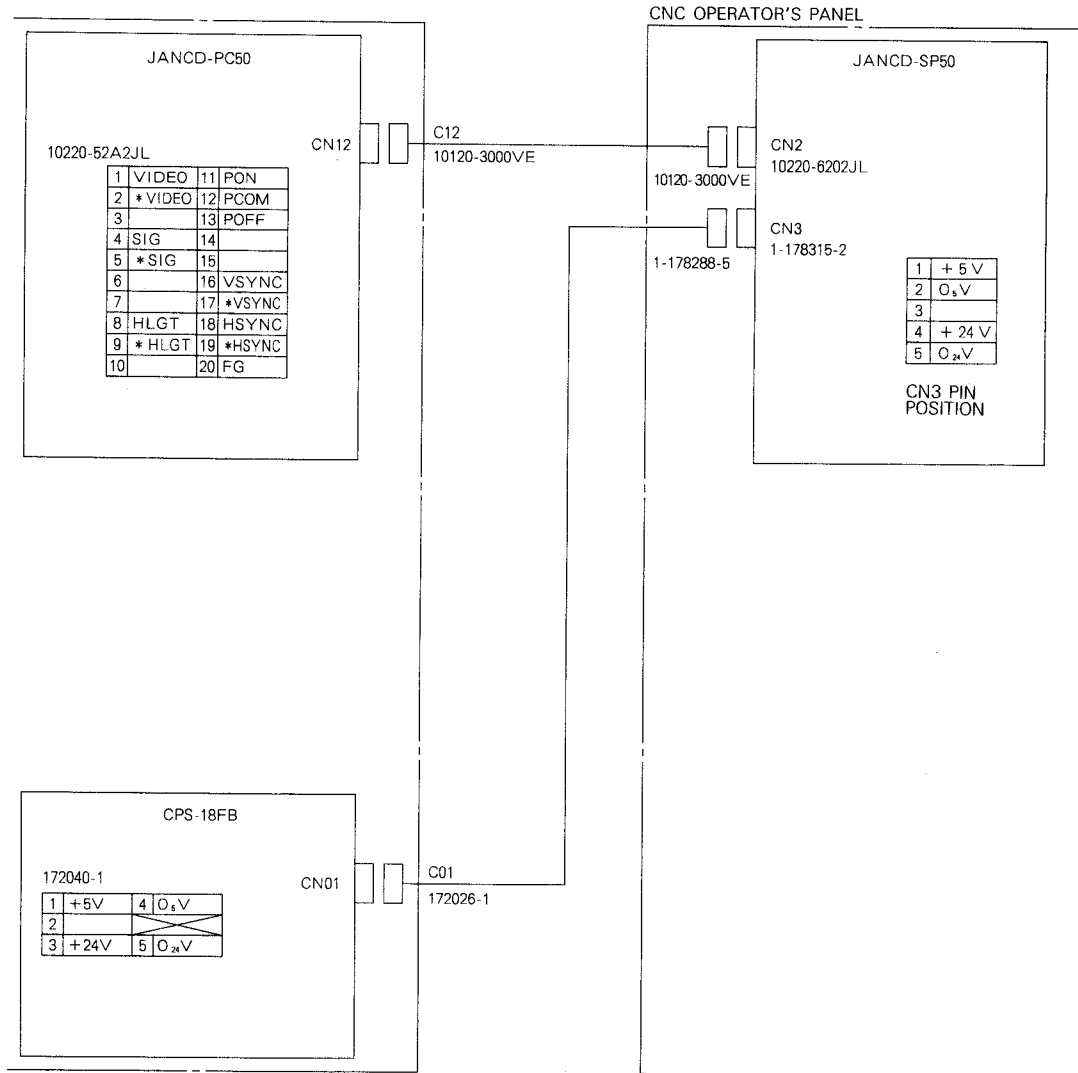
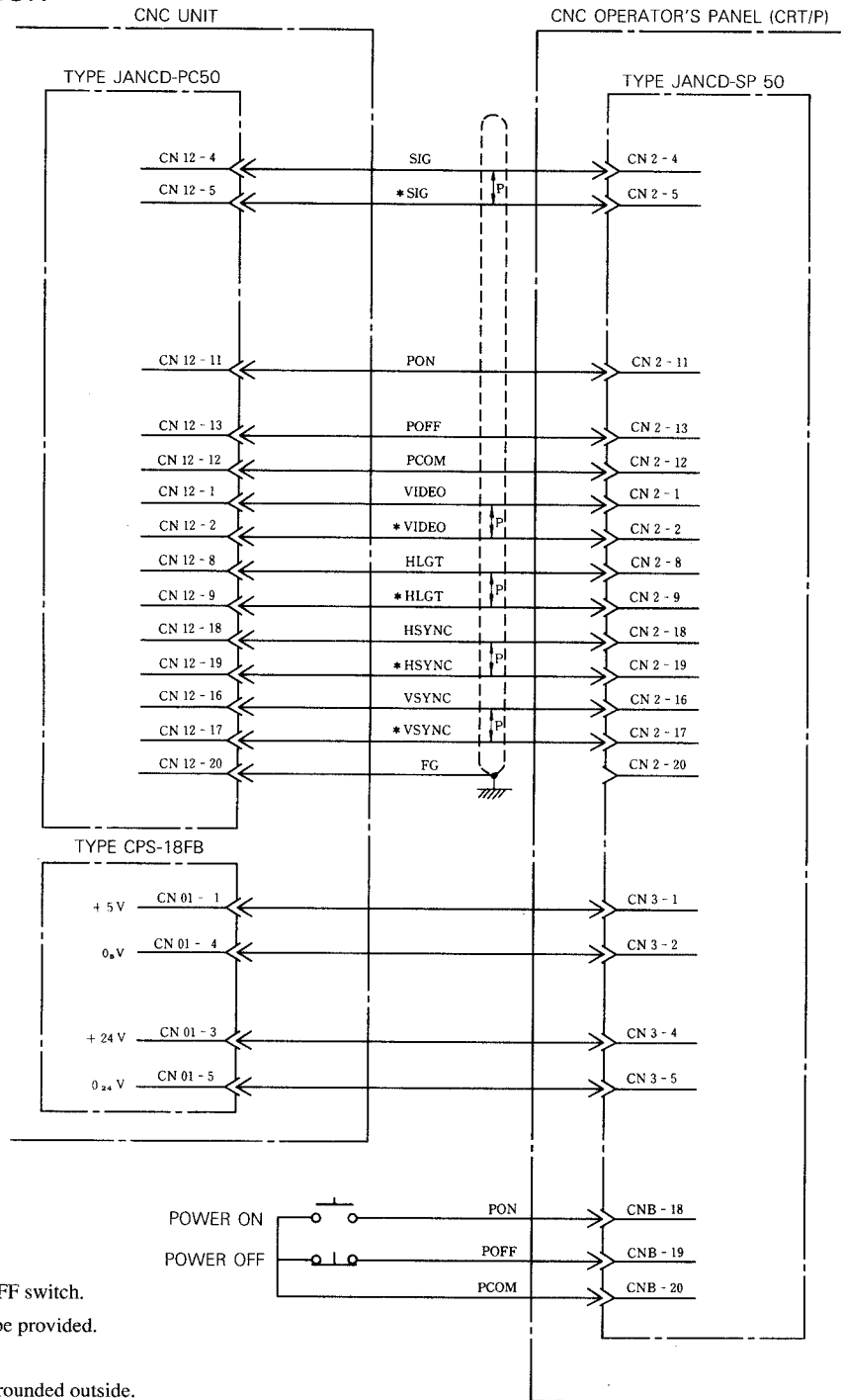

Fig. 8.1

8.2 DETAILS OF CONNECTION



* Vertical type CNC contains a power ON/OFF switch.
A special external circuit does not have to be provided.

Notes:

1. The shield enclosure does not have to be grounded outside.
2. Power ON/OFF can be selected by the panel power ON/OFF (POF) and/or remote power ON/OFF (EOF) by a shorting plug.

Setting in Main board model JANCD-PC50

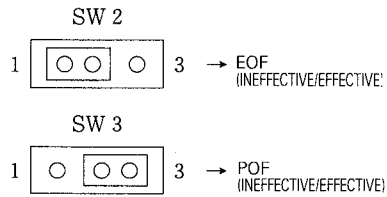
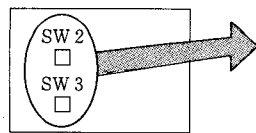

Settings prior to factory shipment

SW2, SW3 Setting

	Panel/Power ON/OFF (POF)	Remote Power ON/OFF (EOF)	Panel and Remote Power ON/OFF
SW 2	OFF/ON	OFF/ON	OFF/ON
SW 3	OFF/ON	OFF/ON	OFF/ON

Fig. 8.2 Connecting Power Unit (Type CPS-18FB) and PC Board (Type JANCD-PC50) to CNC Operator's Panel (CRT/P)

9. CONNECTION OF MANUAL PULSE GENERATOR

9.1 CONNECTION TO EACH UNIT

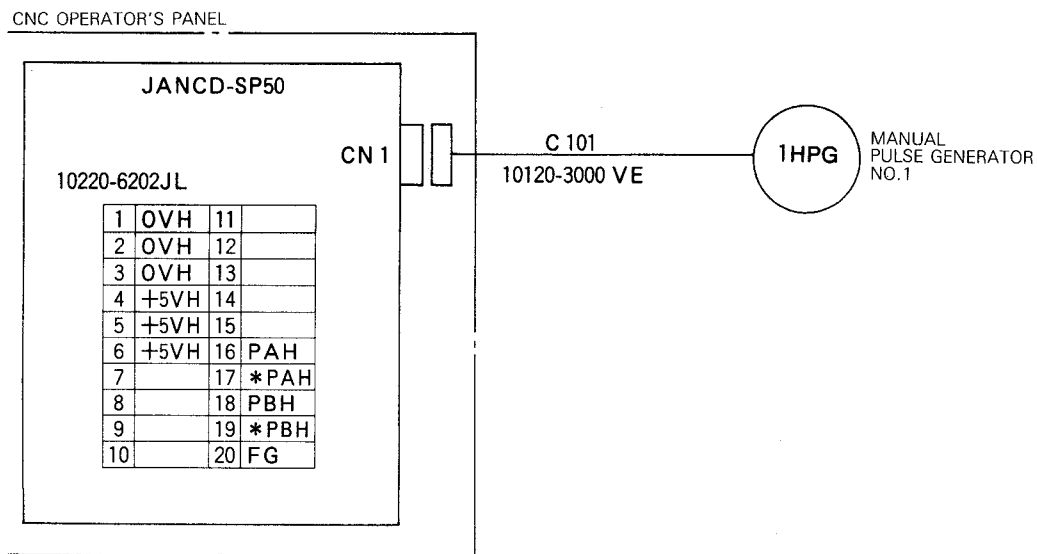
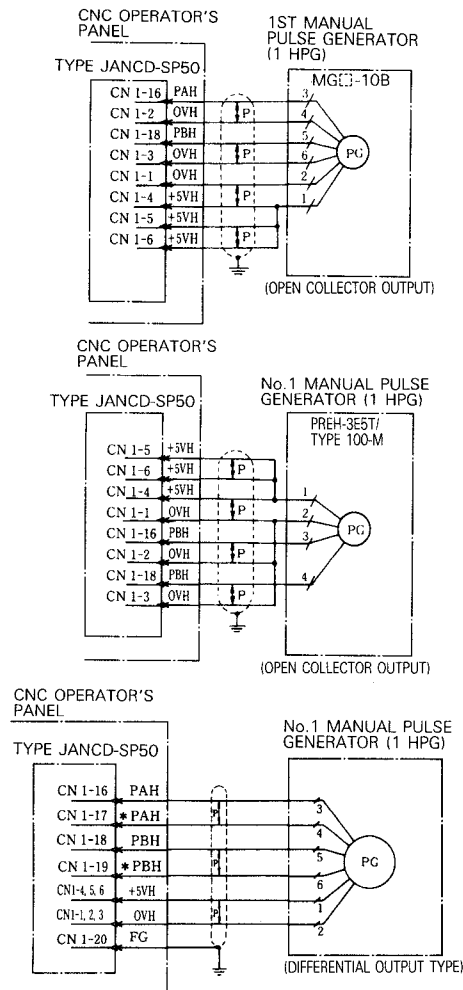

Fig. 9.1

9.2 DETAILS OF CONNECTION

(1) 1st Manual Pulse Generator



Notes:

1. The HPG power supply is a constant +5V.
2. An open collector (cable length 5 m or less) or differential output (cable length 5 m or more) can be used for HPG output.
3. Shielded cables are not needed if the cable lengths are less than 1 m. Twisted-pair cables can be used. Use twisted-pair shielded cables if the cable lengths are more than 1 m and ground the cable shield enclosure using a ground plate inside the panel or CN1-20 pins (FG).

10. CONNECTION OF INPUT SEQUENCE

10.1 CONNECTION TO EACH UNIT

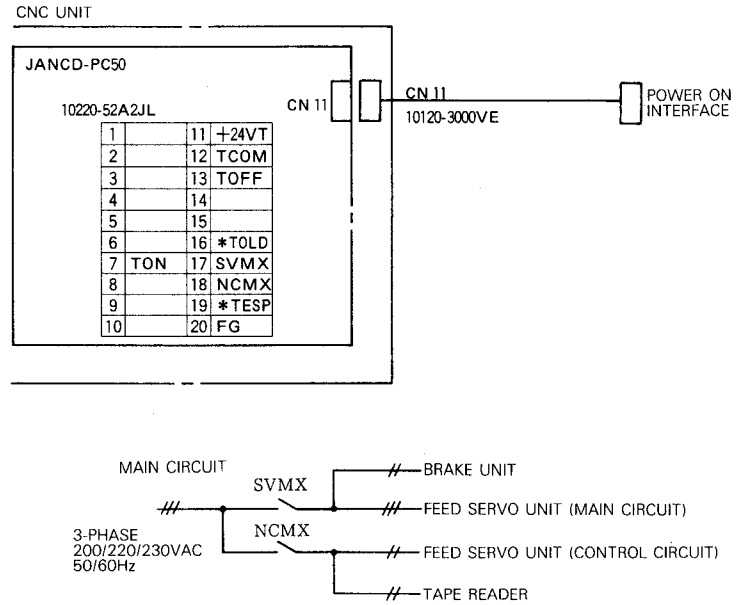

Fig. 10.1

10.2 DETAILS OF CONNECTION

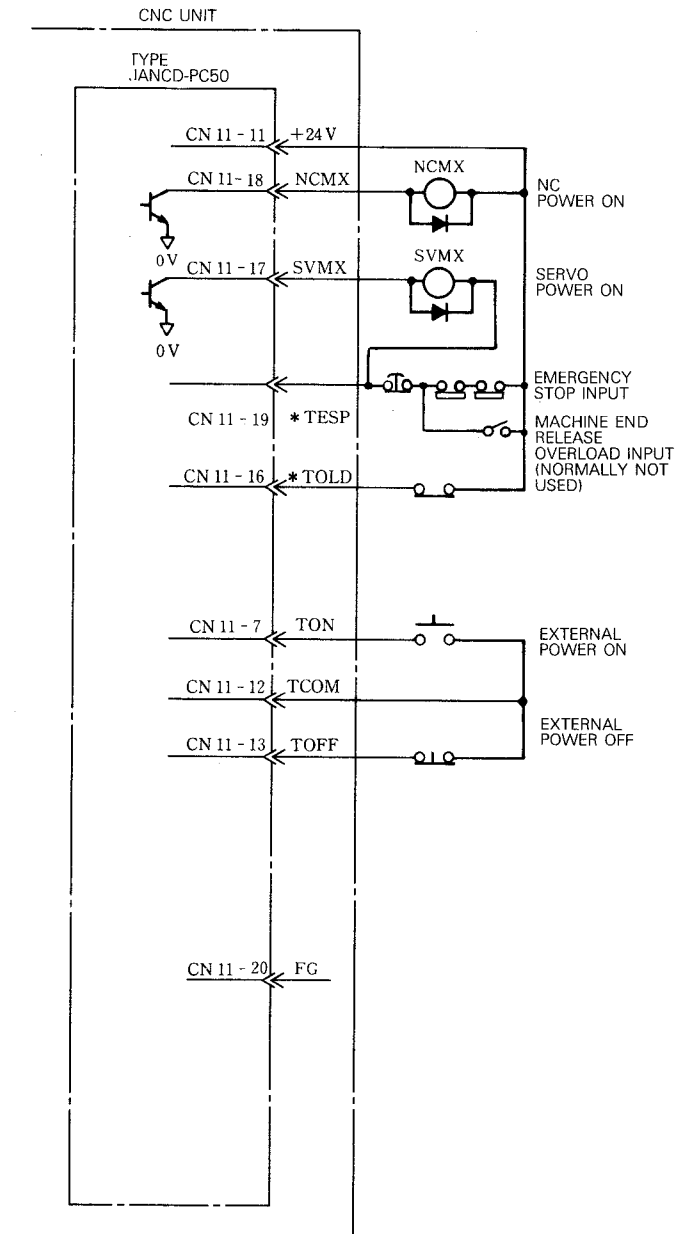
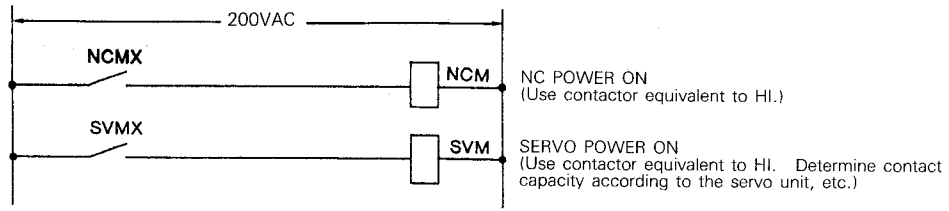

Fig. 10.2 Connecting Input Sequence to PC Board
(Type JANCD-PC50)

The connection example of the PC board is shown below.



200/220/230VAC, 50/60Hz

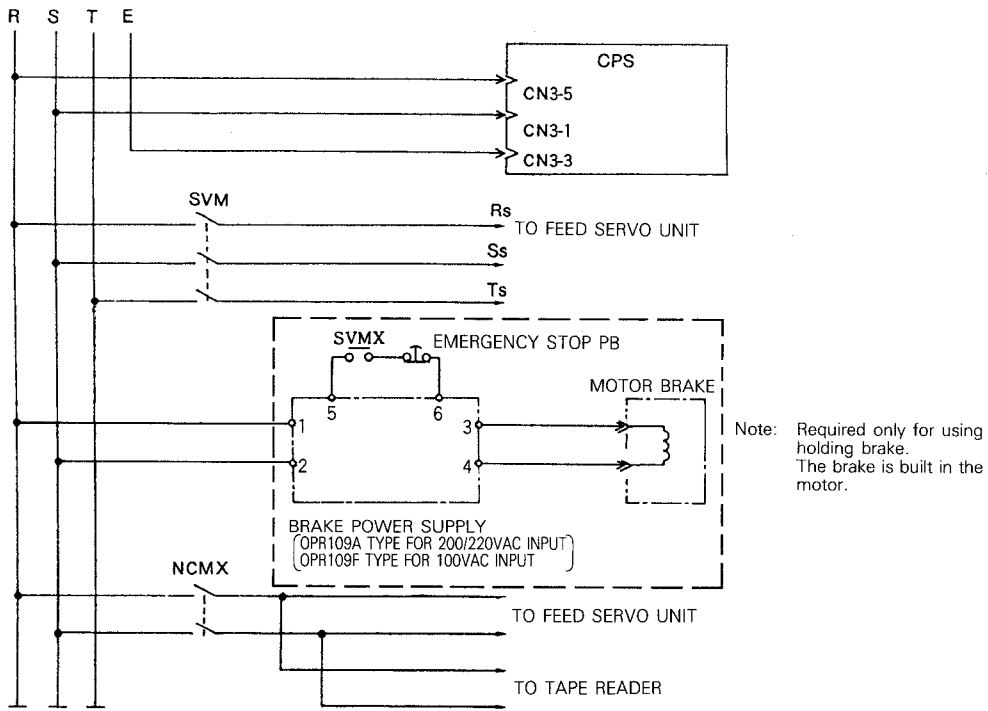

Fig. 10.3

10.3 DETAILS OF SIGNALS

10.3.1 NC POWER ON (NCMX) AND SERVO POWER ON (SVMX)

- (1) NCMX: This output is turned ON when the logic circuit of the control is energized.
- (2) SVMX: This output is turned ON when the servo unit is energized. With an external servo unit, turn ON the power supply when this signal is outputted.
- (3) The power supply turning ON sequence is as follows:
 - (a) Close the power supply main switch for the control.
 - (b) Either push the POWER ON button on the CNC operator's panel, or close the circuit between EON and ECM. Then, the logic circuit and the servo control circuit are both energized, and the circuit between NCMX (NC power input and output) is closed.

With an external servo unit, design the servo control circuit power input sequence so that the circuit is energized at the output of NCMX signals.

- (c) Again make the same power switching (pushing the POWER ON button or closing the circuit between EON and ECM). Now, the servo power supply is turned ON, and the circuit between SVMX (servo power input and output) is closed.

With an external servo unit, design the servo power circuit power input sequence so that the circuit is energized at the output of SVMX signals.

- (d) When the external circuit is ready after the circuit between SVMX is closed, and the control becomes ready, close the MRD (machine ready) input of the I/O module. Then, RDY is displayed on the CRT, and operation becomes possible.

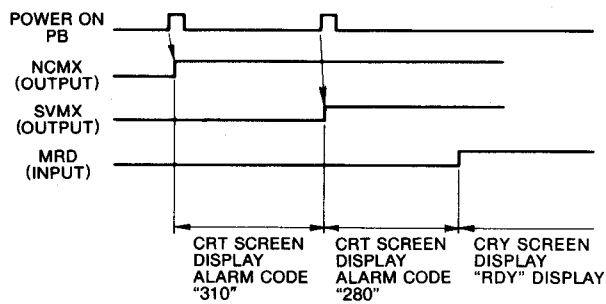

Fig. 10.4 Time Chart of Power Supply Turning on Sequence

10.3.2 EMERGENCY STOP (TESP) INPUT

When the circuit between emergency stop input terminals (TESP) is open, the control stops totally the servo power supply is turned off, and the emergency stop output (*ESPS) of general purpose I/O module is opened.

10.3.3 EXTERNAL POWER ON-OFF (EON, EOF, ECM) INPUT

The control can be switched on and off by external input signals, in the same way as the depressing of the POWER ON/OFF buttons on the CNC operator's panel. When the circuit between EON and ECM is closed, the logic circuit or servo power of the control is energized. When the circuit between EOF and ECM is opened, the logic circuit or servo power of the control is deenergized.

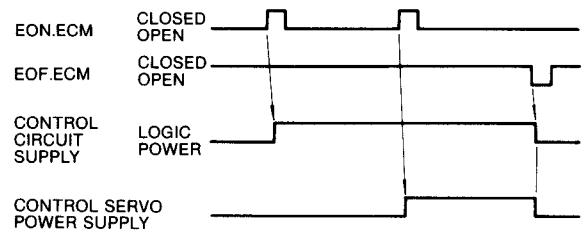

Fig. 10.5 External Power ON-OFF

10.3.4 OVERLOAD (*TOLD) INPUT

Short-circuit T24 (CN11-16) if this input is not used. (Normally this input is not used.)

11. CONNECTION TO FEED SERVO UNIT

11.1 CONNECTION TO EACH UNIT

(1) For Lathe

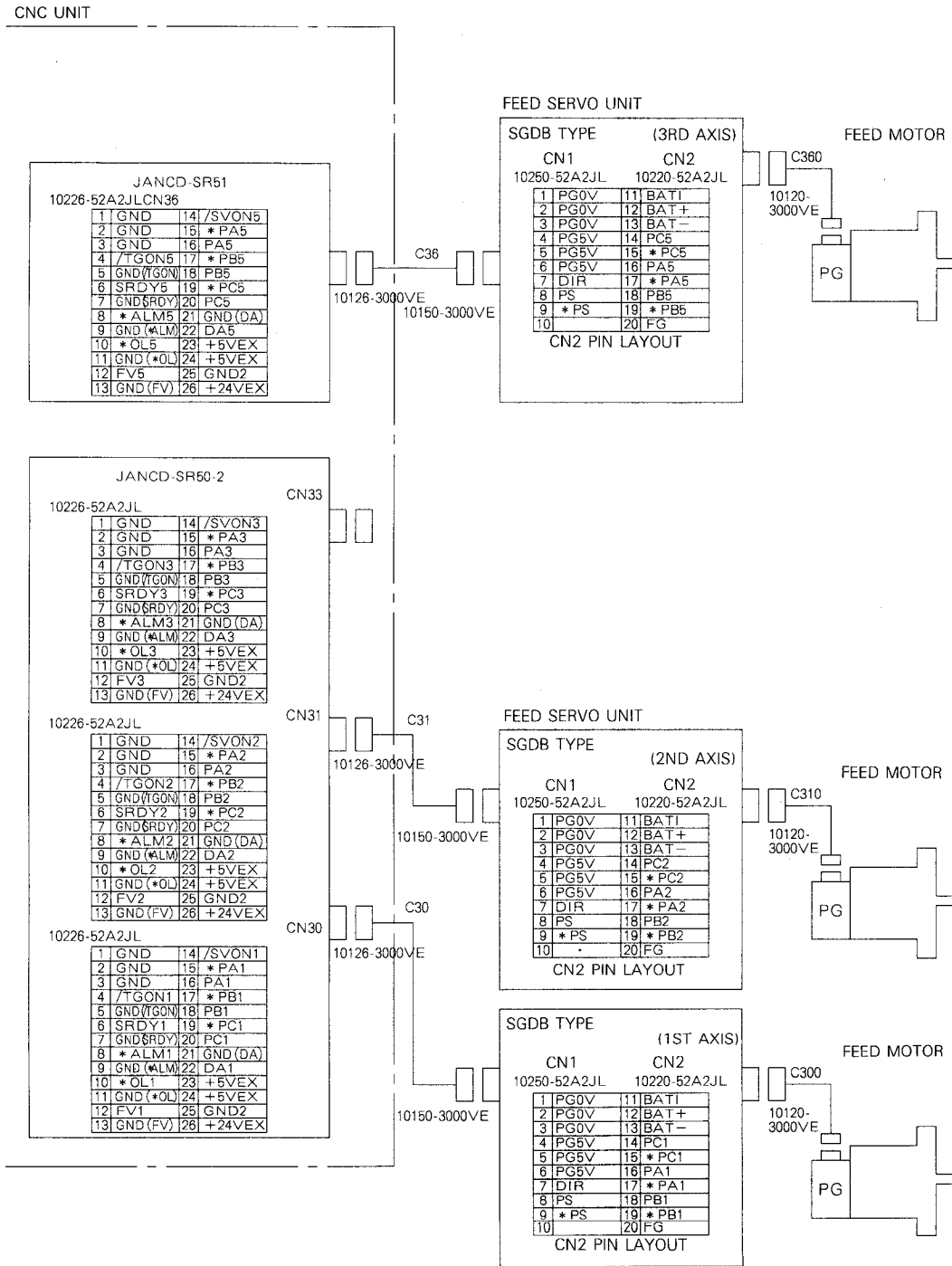

Fig. 11.1 Cable Connection between 1st Axis and 3rd Axis

(2) For Machining Centers

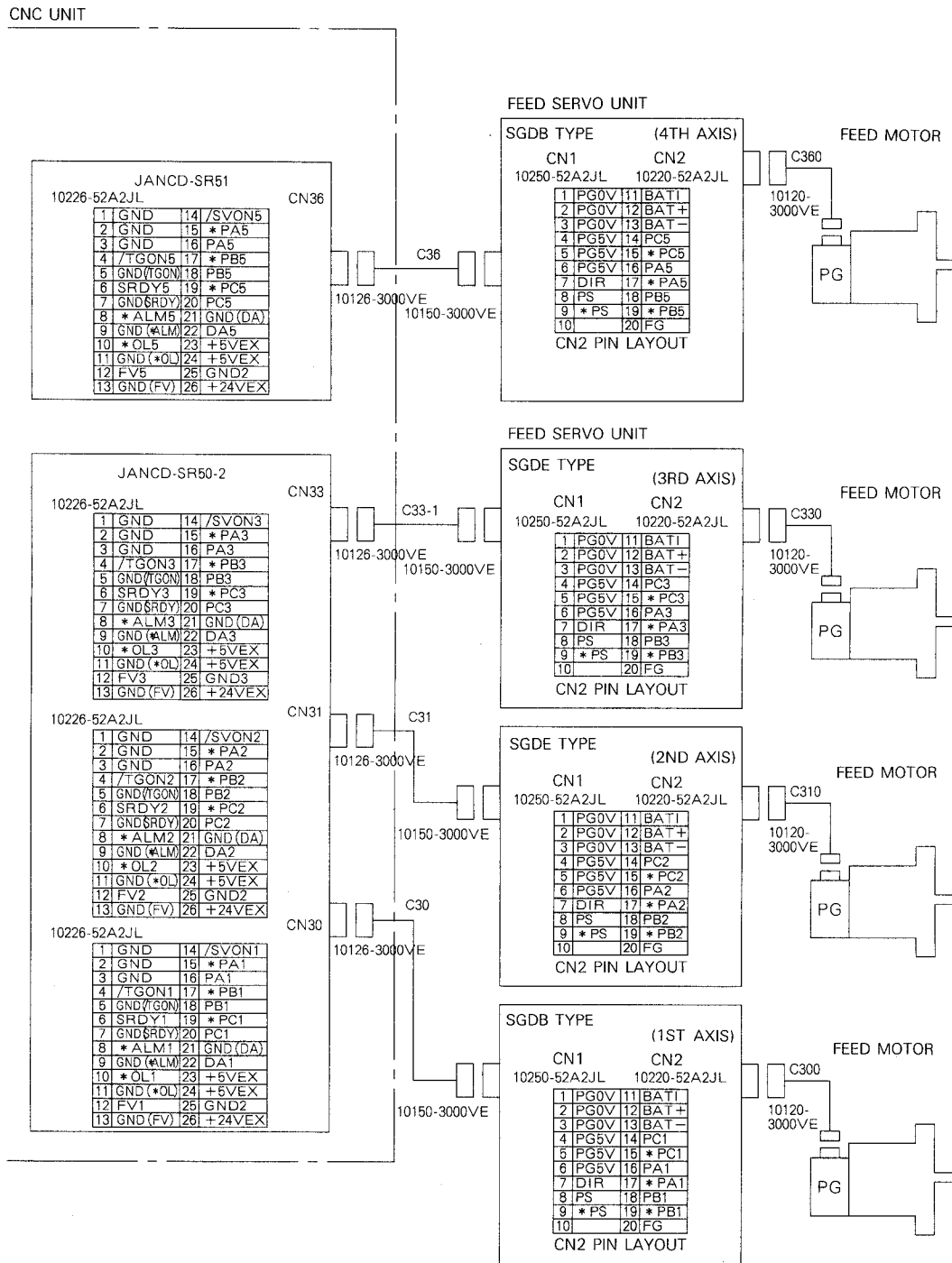

Fig. 11.2 Cable Connection between 1st Axis and 4th Axis

11.2 DETAILS OF CONNECTION

(1) For Lathe

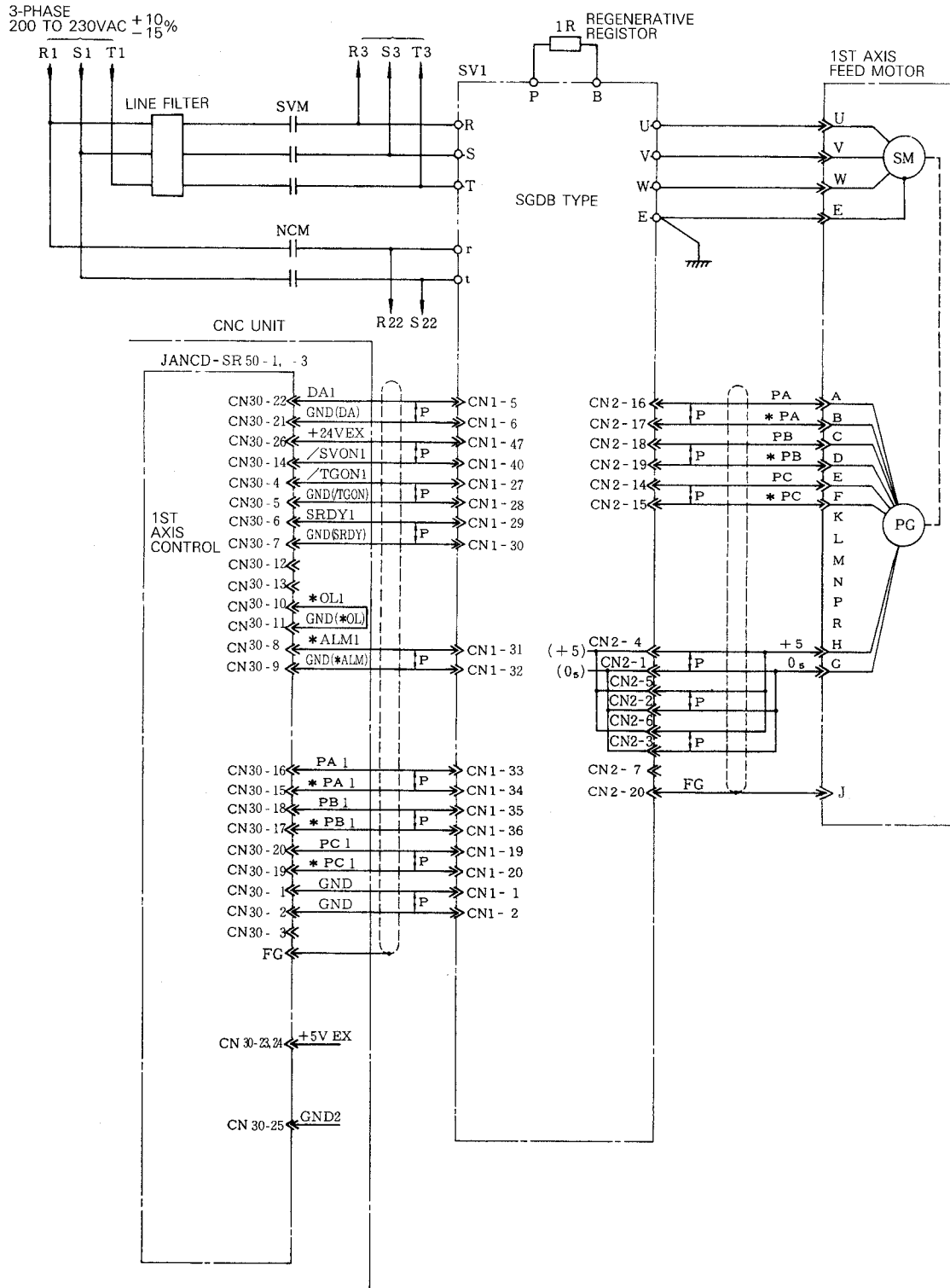

Fig. 11.3 Connection to Feed Servo Unit (1st Axis)

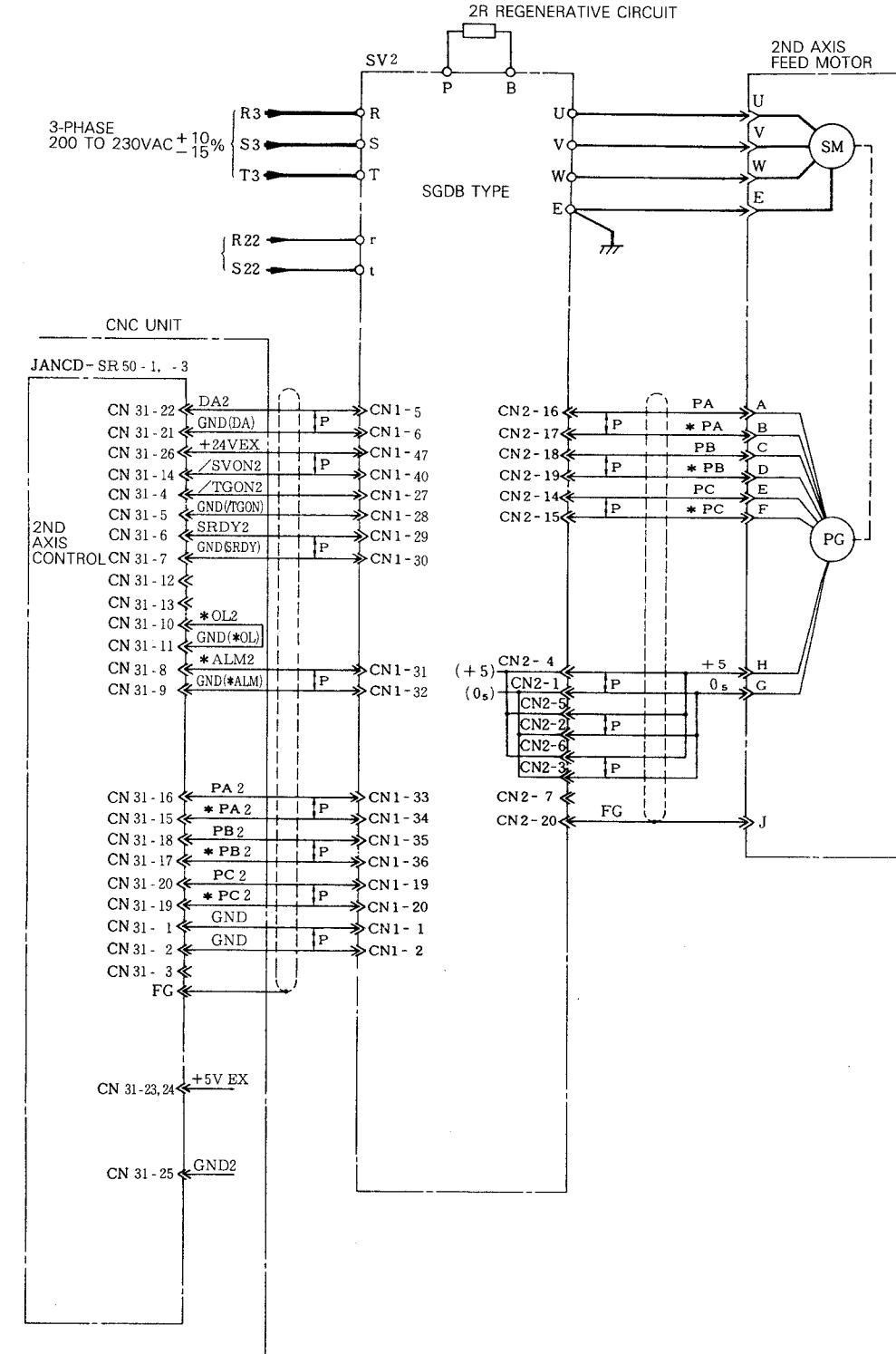

Fig. 11.4 Connection to Feed Servo Unit (2nd Axis)

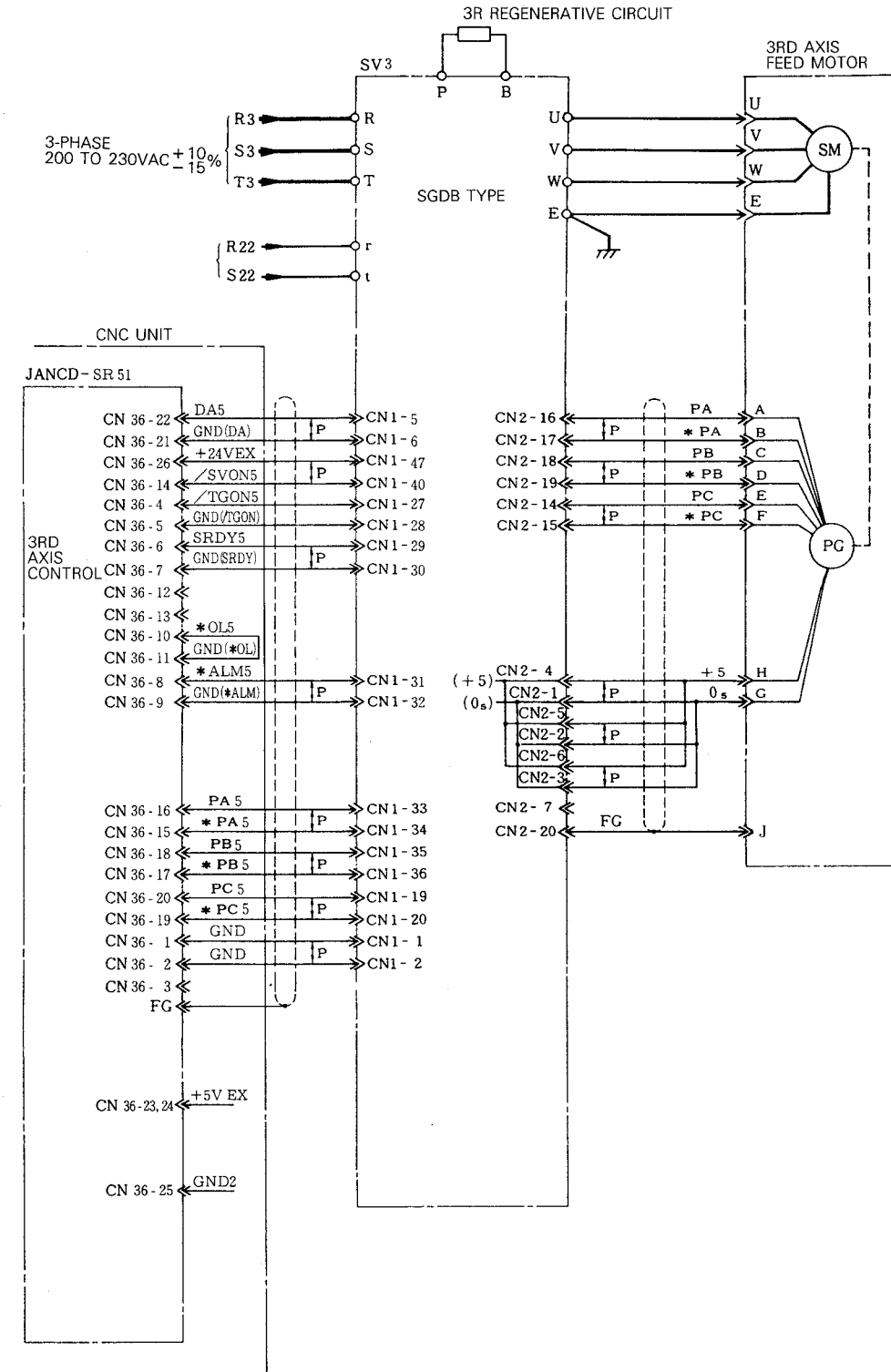

Fig. 11.5 Connection to Feed Servo Unit (3rd Axis)

(2) For Machining Centers

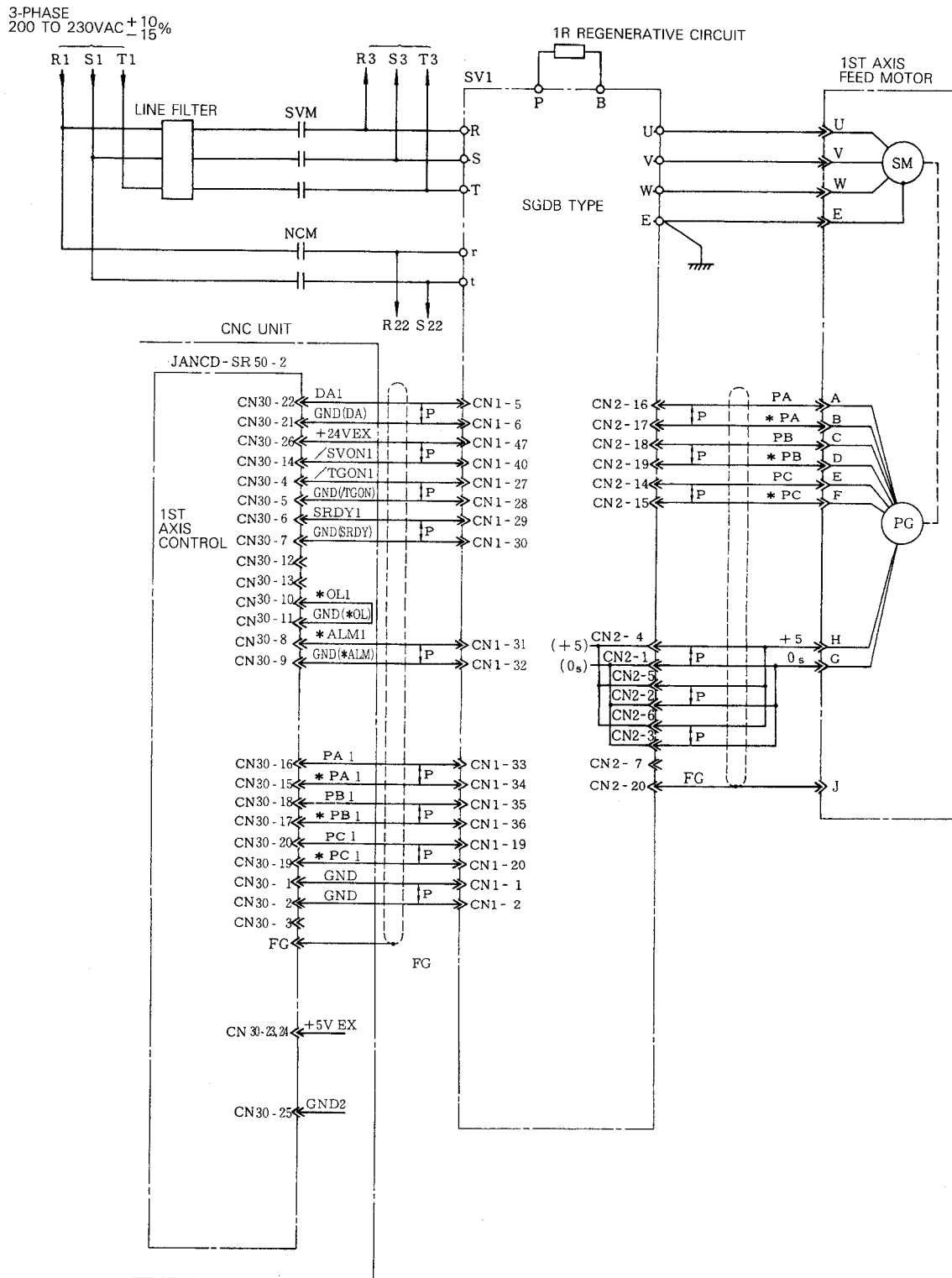

Fig. 11.6 Connection to Feed Servo Unit (1st Axis)

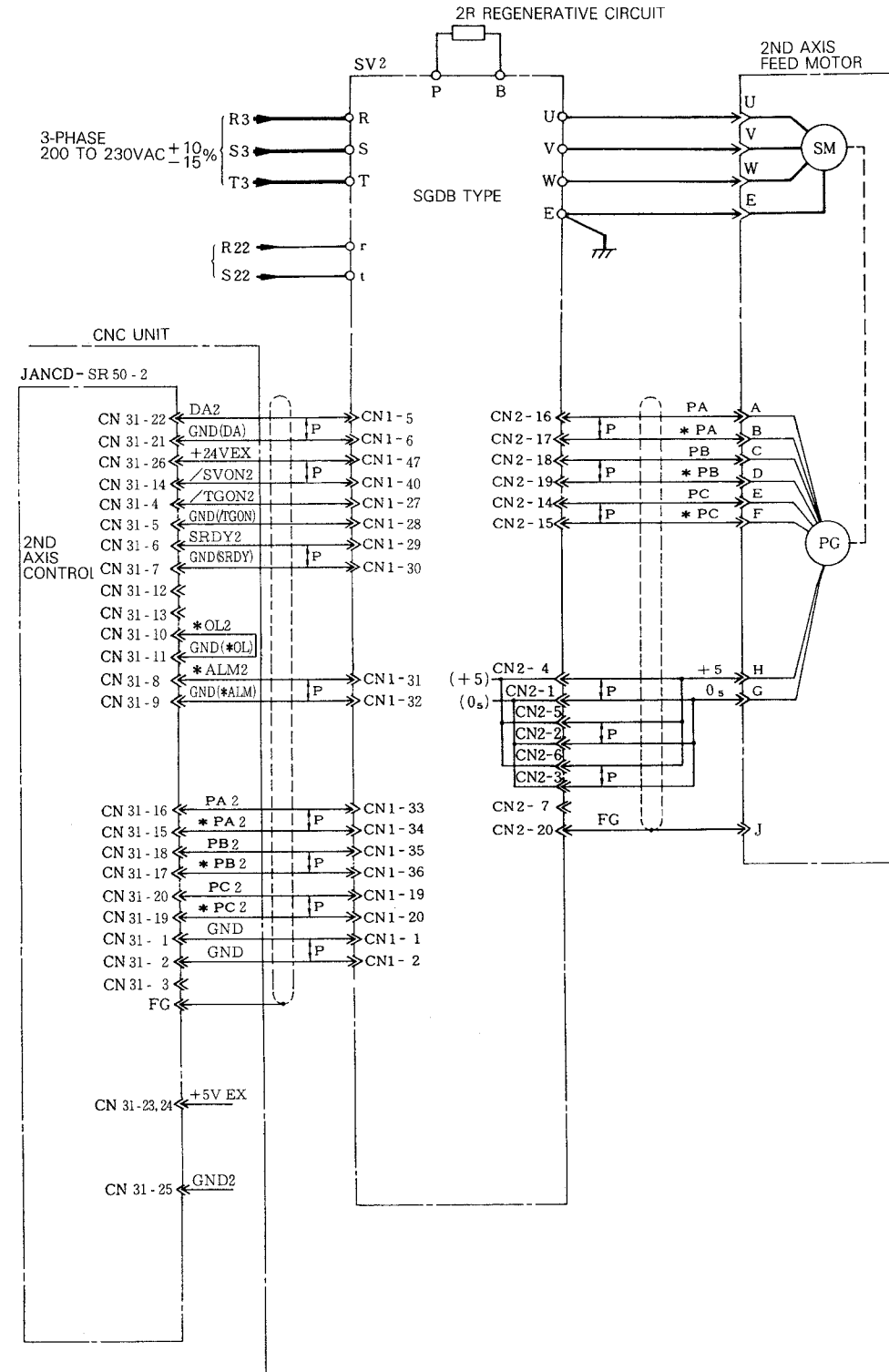

Fig. 11.7 Connection to Feed Servo Unit (2nd Axis)

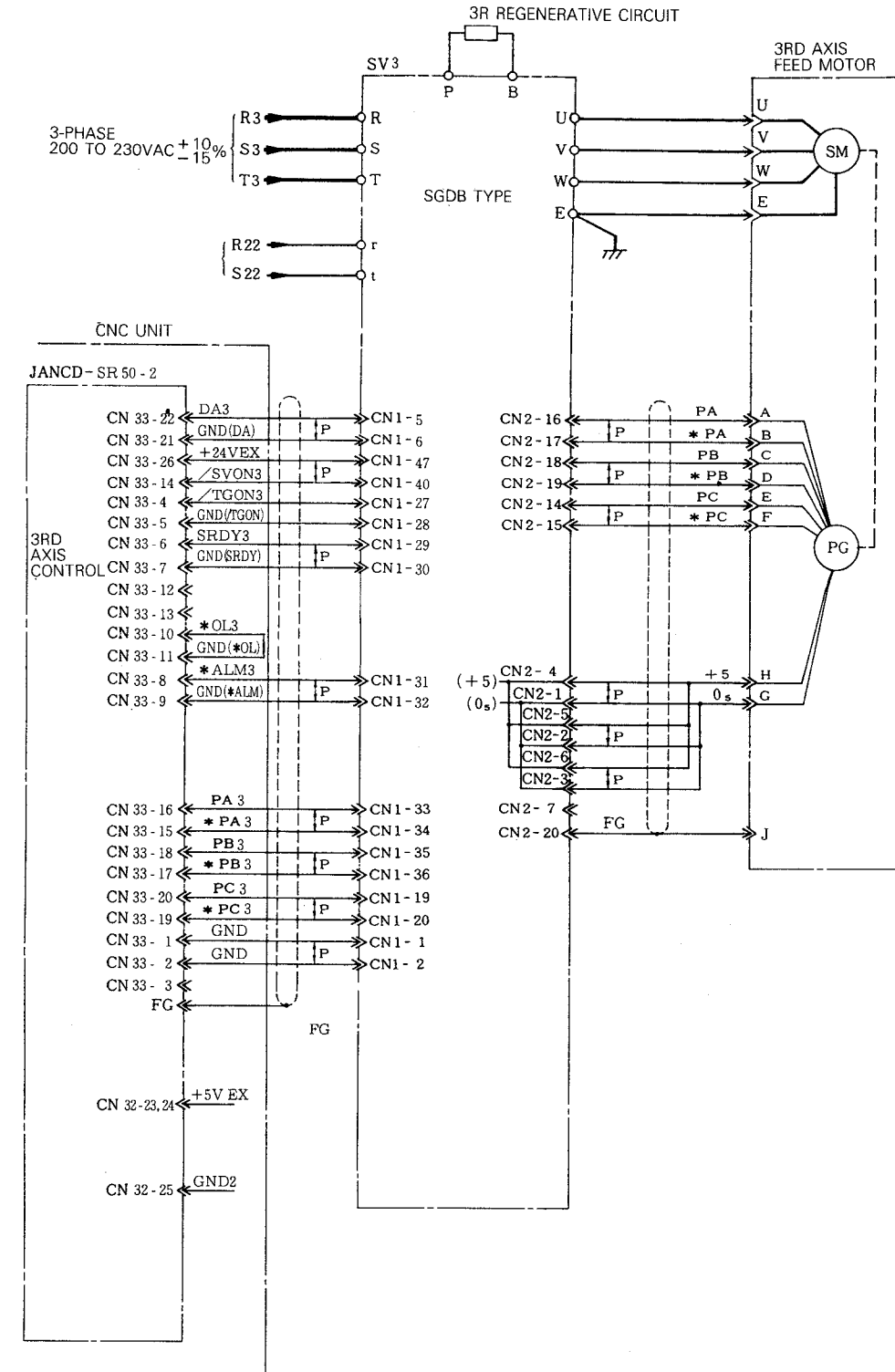

Fig. 11.8 Connection to Feed Servo Unit (3rd Axis)

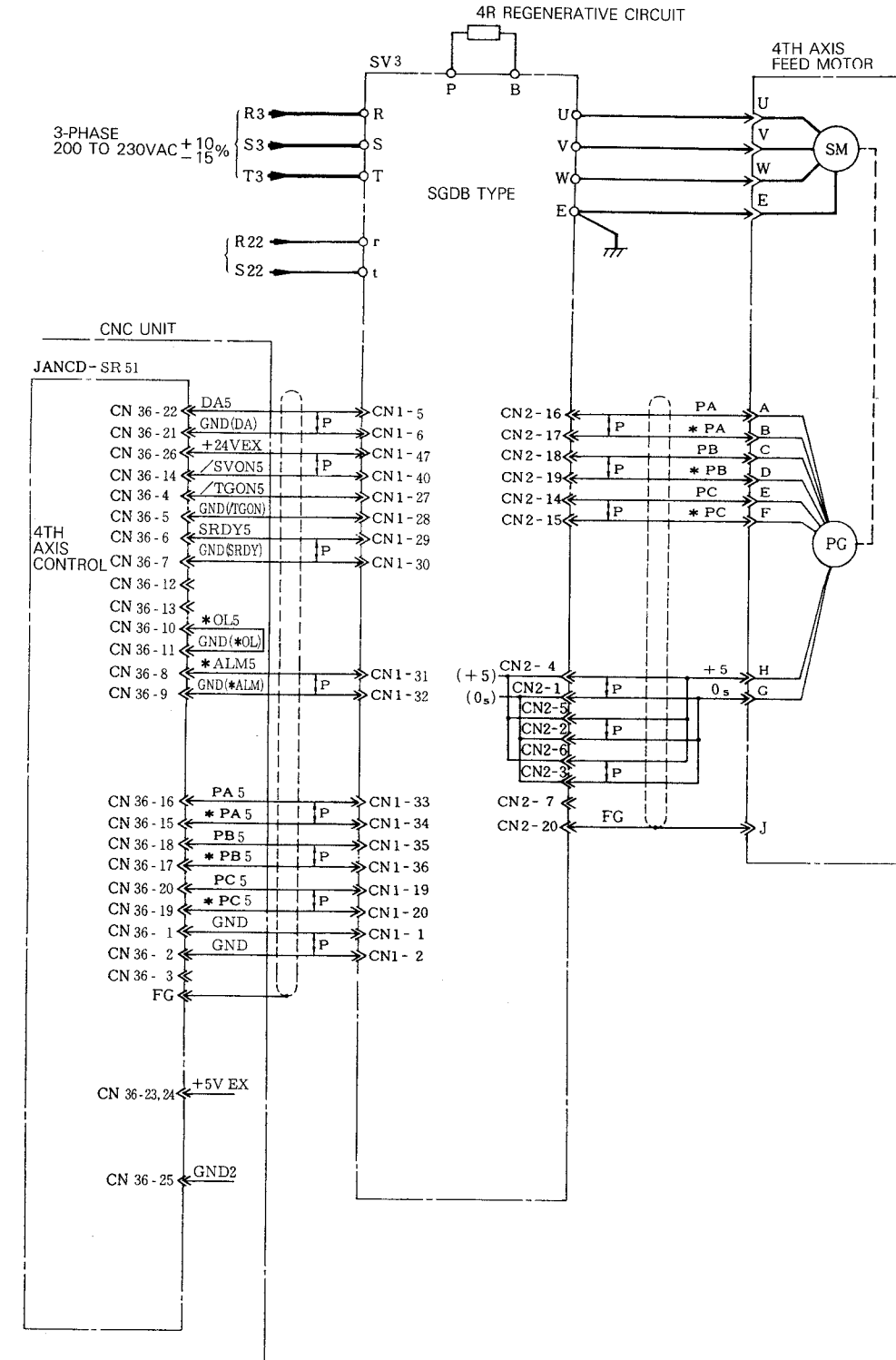
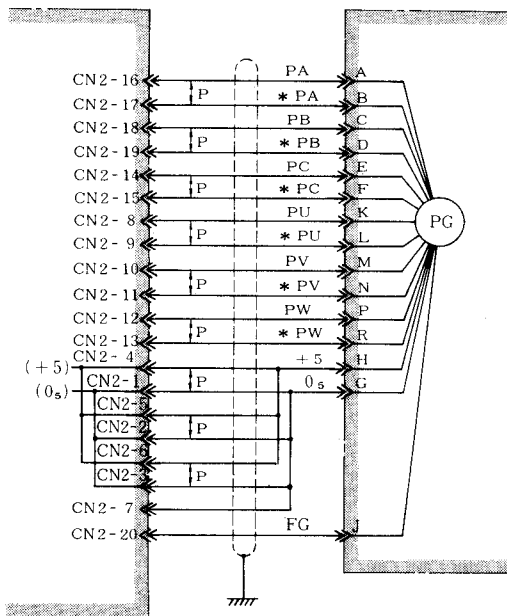

Fig. 11.9 Connection to Feed Servo Unit (4 th Axis)

(1) Connection and Motor Rotating Direction

	Forward Connection	Reverse Connection
Direction of Motor Rotation if "+" moving command is given.	<p>FLANGE SURFACE OF MOTOR CCW</p>	<p>CW</p>

The connection diagram shows forward connection. Connect wires as shown below for reverse connection.



(2) Combination of Drive Unit and Regenerative Resistor

Servo Drive Type CACR-	Regenerative Resistor installed Separately Type MO-
SR03SB	70W-50k (or 30SH, 300W 100Ω)
SR05SB	70W-50k (or 30SH, 300W 100Ω)
SR10SB	70W-50k
SR15SB	70W-50k
SR20SB	140W-25k
SR30SB	140W-25k*
SR44SB	140W-25k*

*Two registers connected in parallel.

(3) Line Filter Installation

- (a) A line filter is installed to prevent radio interference by high frequency generated by the servo drive unit.
- (b) Select the appropriate filter as follows depending on the current per phase of the drive unit input power supply.

Line Filter Type	Current per Phase of Input Power Supply
LF310	10A max
LF320	20A max
LF330	30A max
LF340	40A max

(4) Connection to Motor with Brake

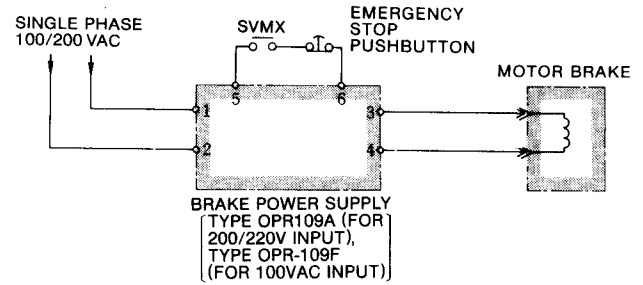

- Do not short-circuit output terminals 3 and 4.
- Tightly fasten terminal board screws.
- Protective devices are built-in. External protectors are not needed.
- The contact making and breaking current for terminals 5 and 6 shall be 5 to 10 times the rated current of the brake to be used. Use DC make-break contacts.

12. CONNECTION TO SPINDLE DRIVE UNIT

12.1 CONNECTION TO EACH UNIT

(1) For Motor with Built-in PG

(a) For lathe

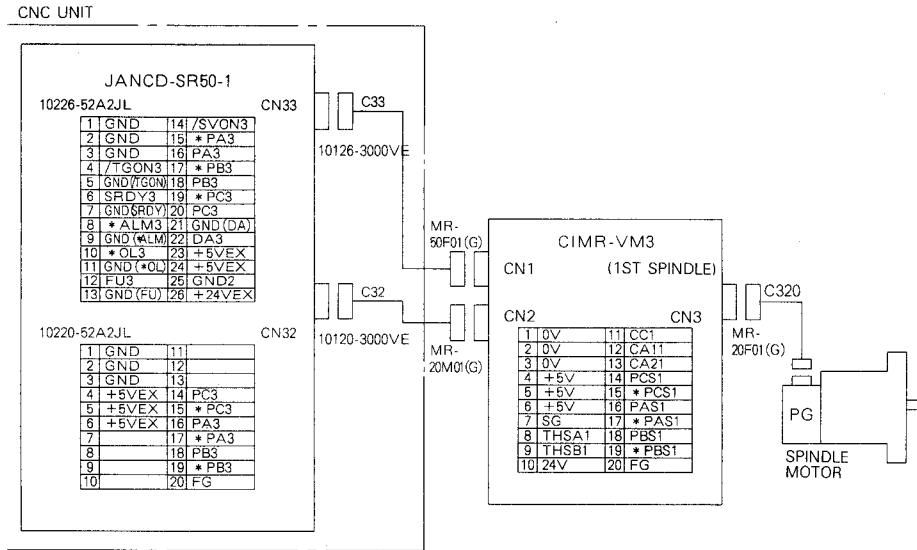

Fig. 12.1

(b) For multi-axis lathe

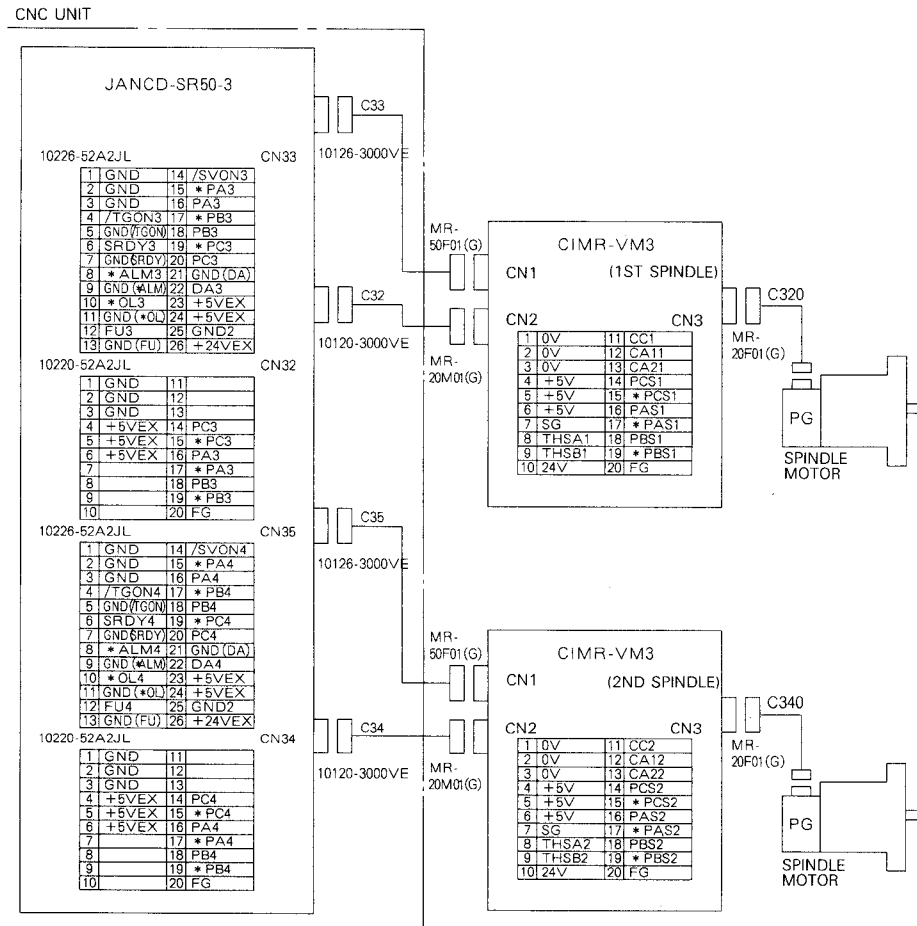

Fig. 12.2

(c) For machining centers

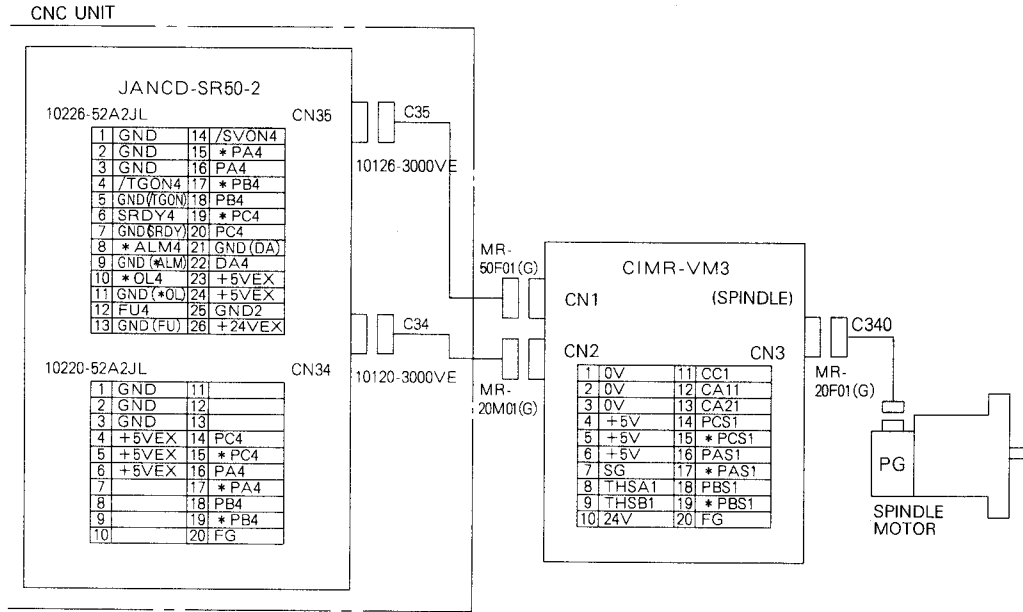

Fig. 12.3

(2) For Motor with Separately Installed PG

(a) For lathe

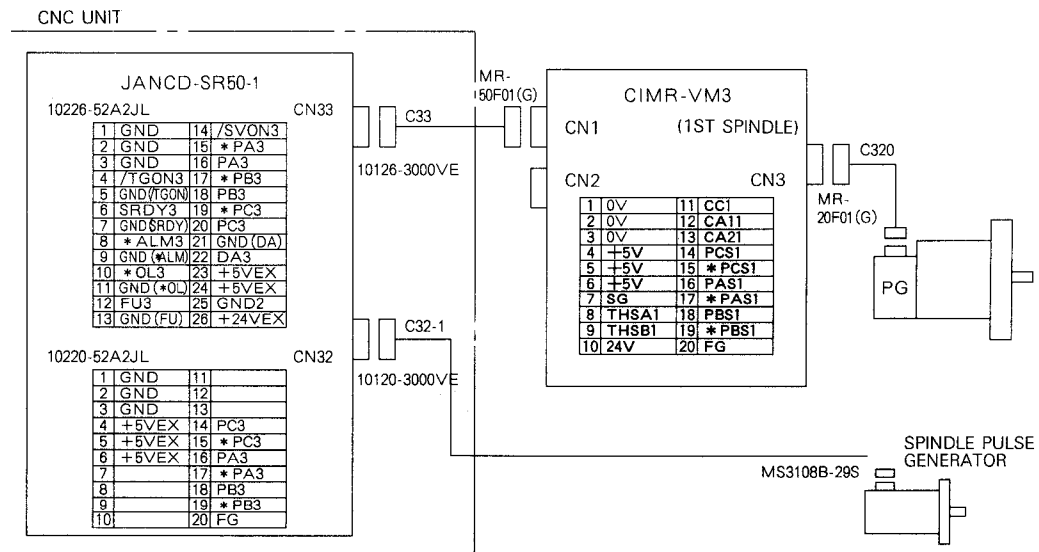

Fig. 12.4

(b) For multi-axis lathe

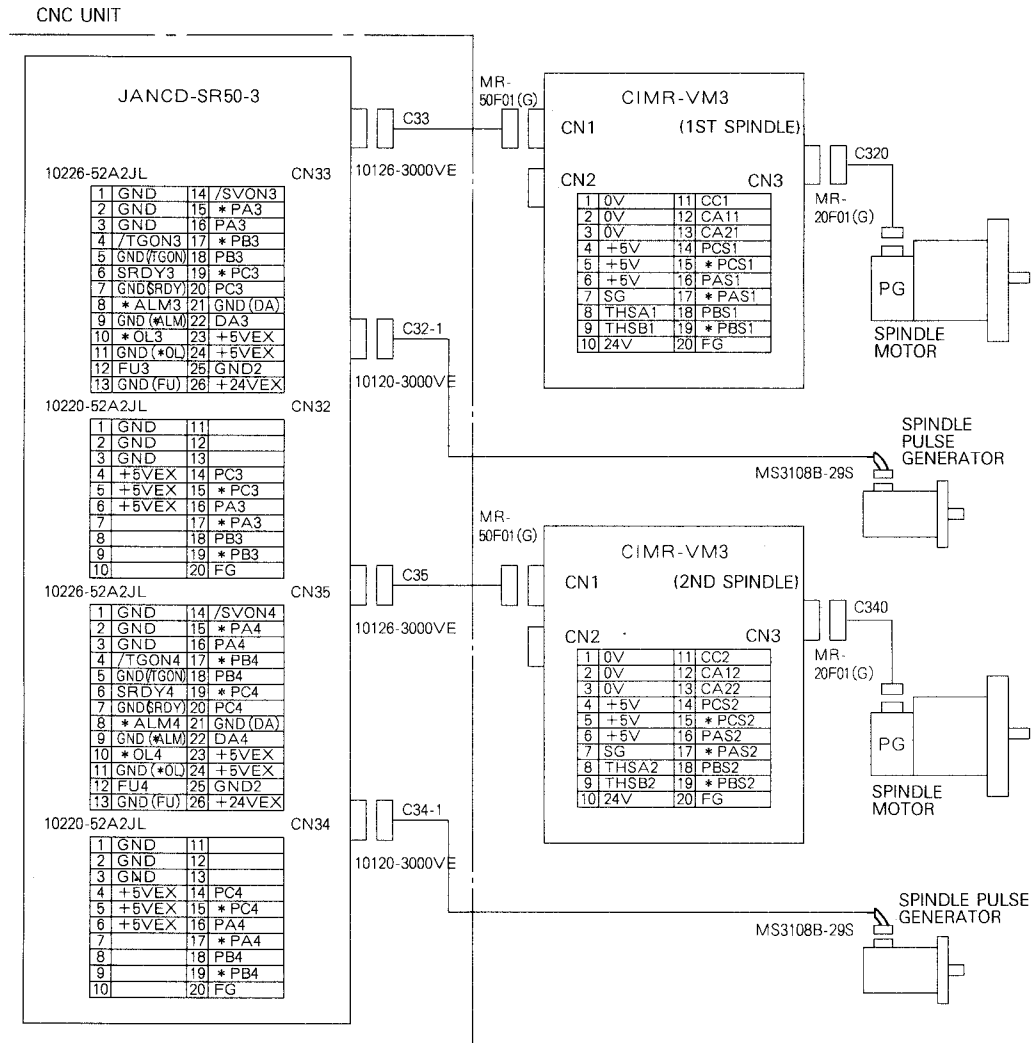

Fig. 12.5

(c) For machining centers

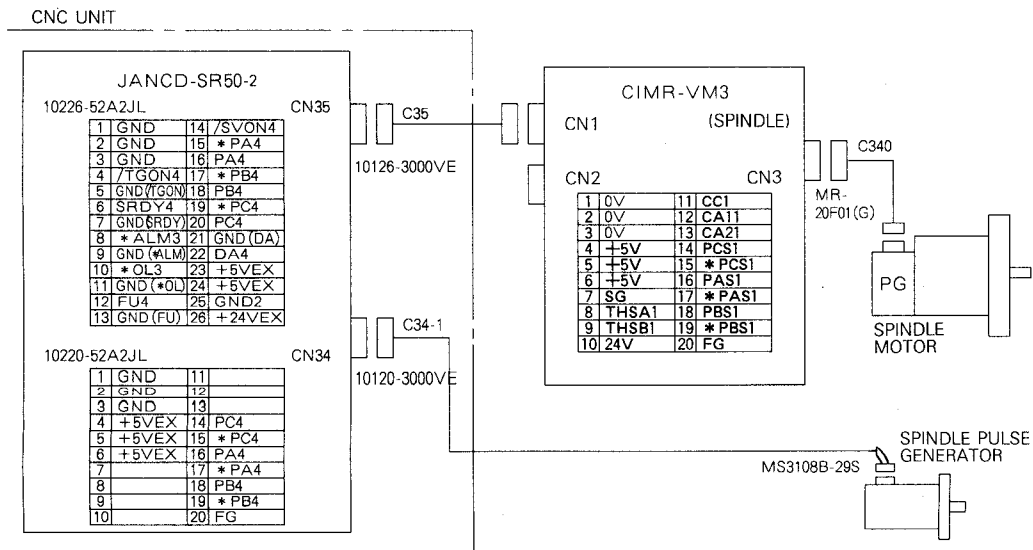

Fig. 12.6

(3) Main Circuit

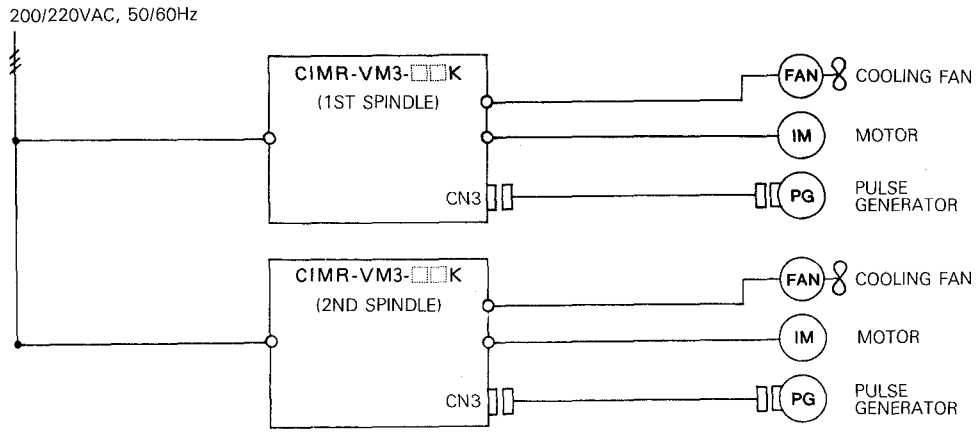

Fig. 12.7 Connection to Main Circuit

12.2 DETAILS OF CONNECTION

(1) For Motor with Built-in PG

(a) For lathe

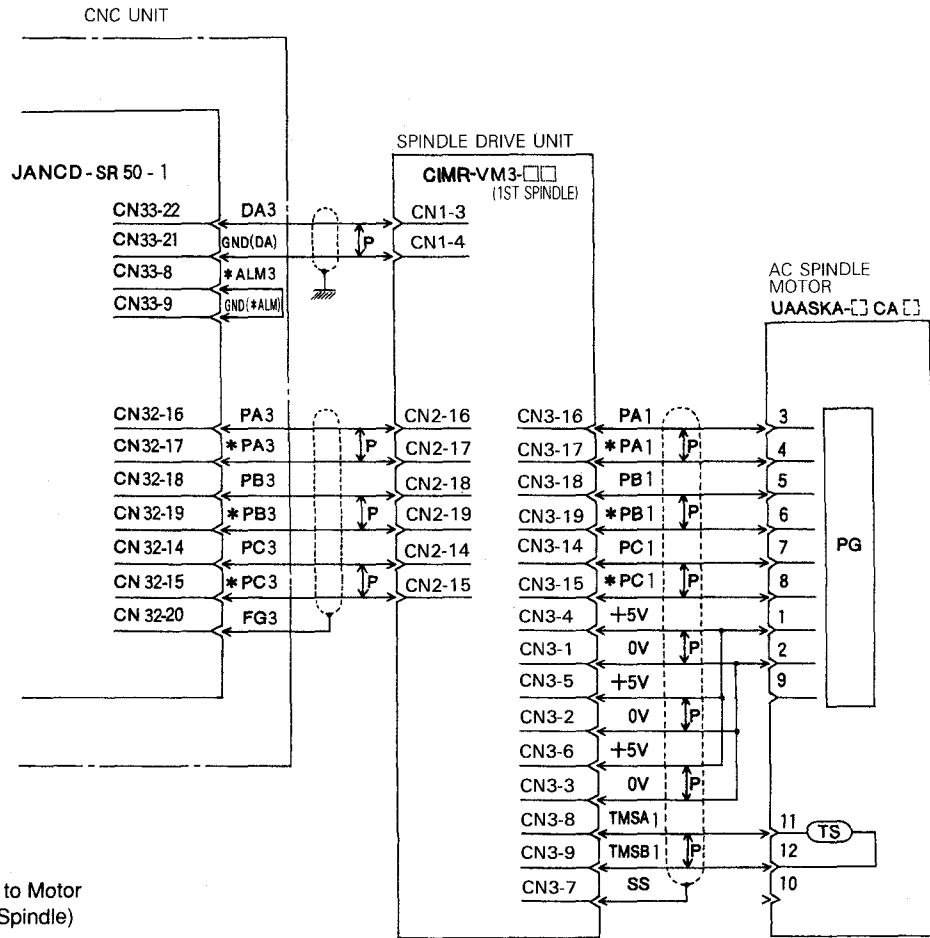

Fig. 12.8 Connection to Motor with Built-in PG (1st Spindle)

(b) For multi-axis lathe

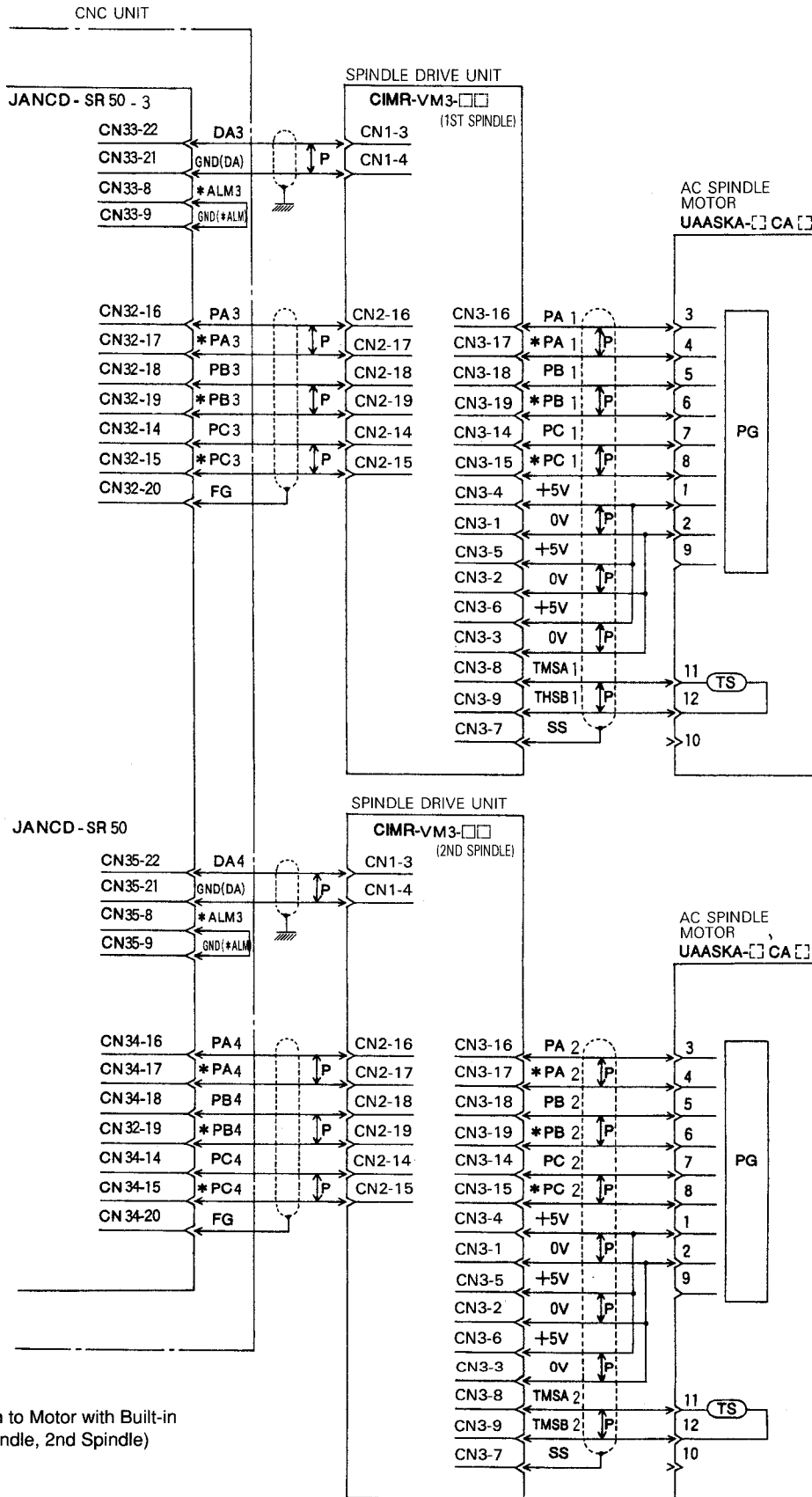

Fig. 12.9 Connection to Motor with Built-in PG (1st Spindle, 2nd Spindle)

(c) For machining centers

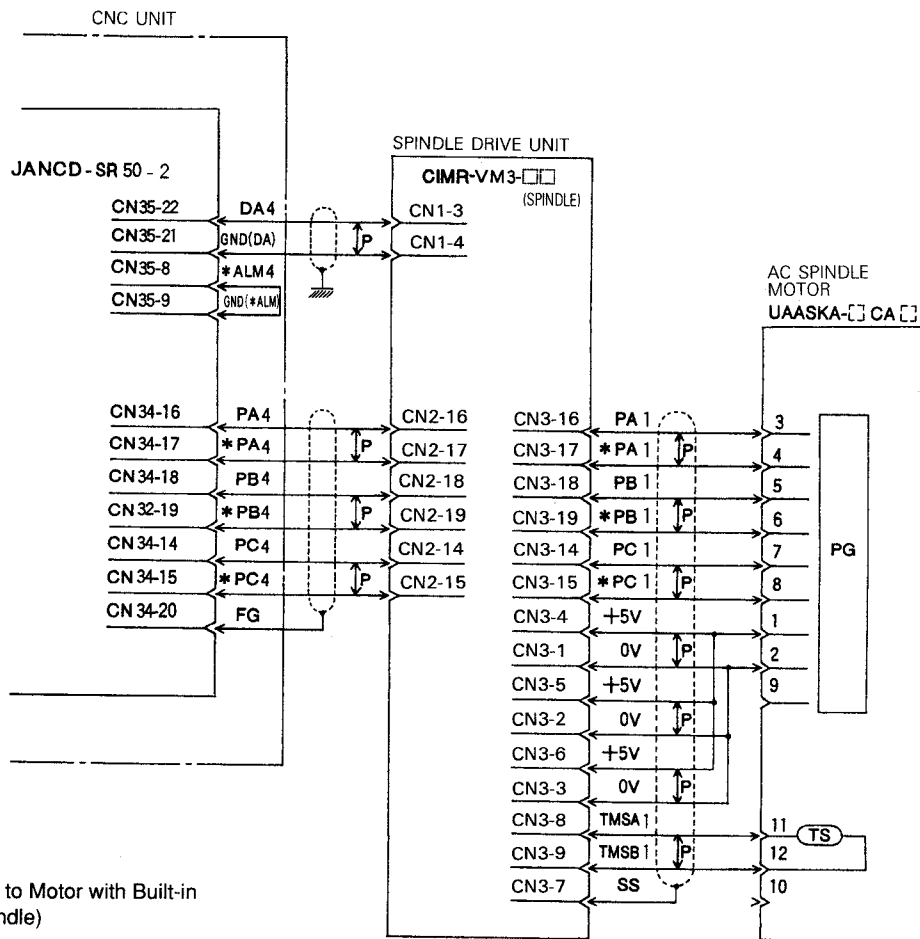

Fig. 12.10 Connection to Motor with Built-in PG (Spindle)

(2) For Motor with Separately Installed PG

(a) For lathe

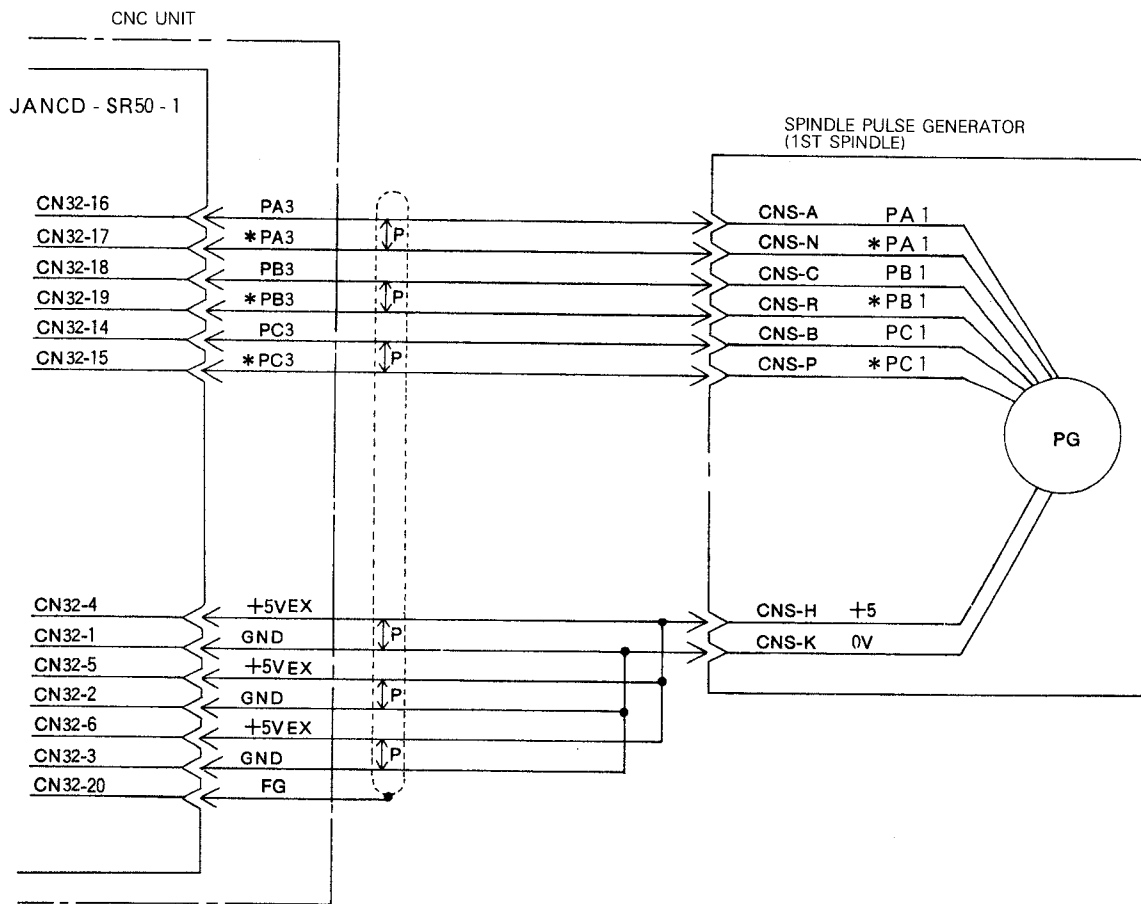

Fig. 12.11 Connection to Motor with Separately Installed PG (1st Spindle)

(b) For multi-axis lathe

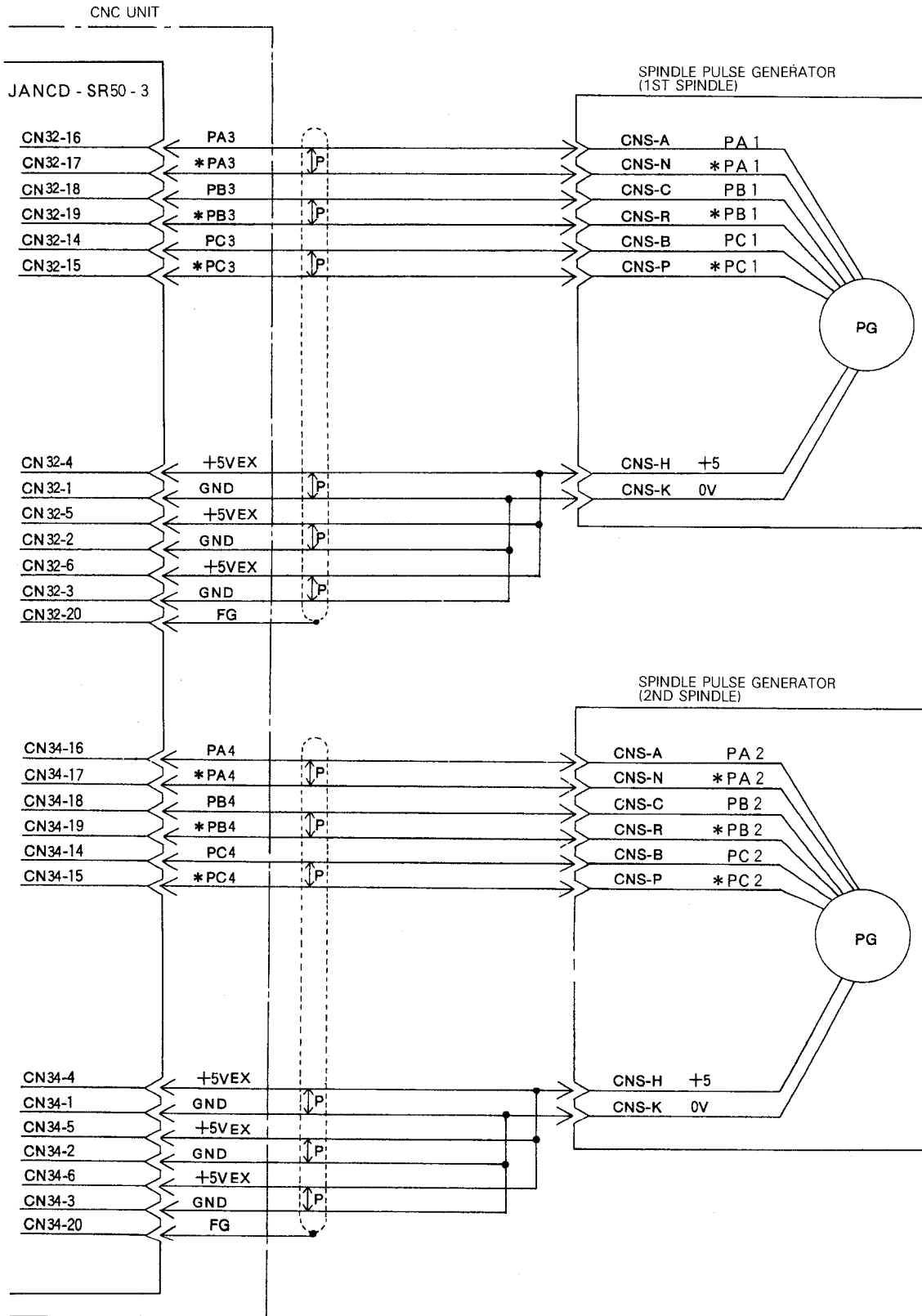

Fig. 12.12 Connection to Motor with Separately Installed PG (1st Spindle, 2nd Spindle)

(c) For machining centers

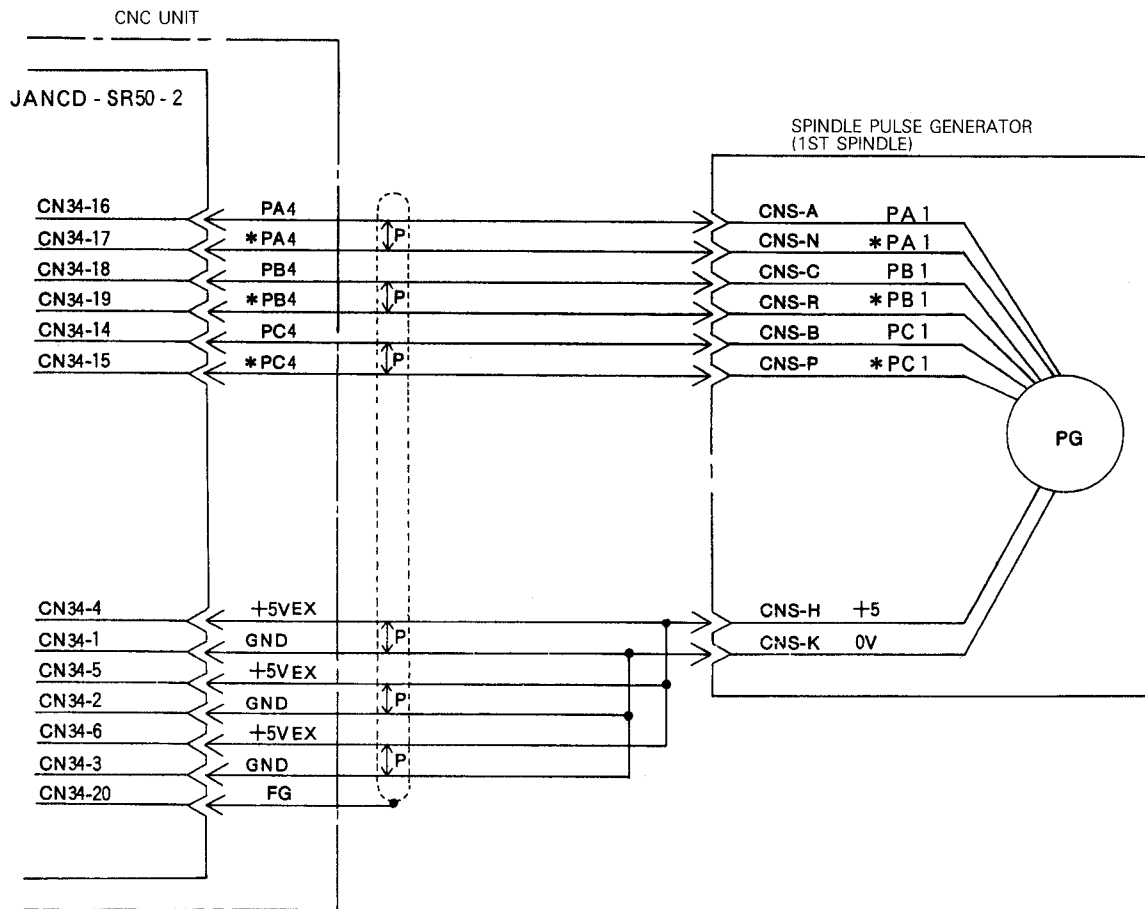

Fig. 12.13 Connection to Motor with Separately Installed PG (Spindle)

12.3 CABLE SPECIFICATIONS

Table 12.1 Main Circuit Cable

Inverter Model CIMR-VM	Rated Current (A)	Size (mm ²) <small>Note</small>			Terminal Name and Screw Size			
		600V Class Vinyl Cable (IV, W)	600V Class Fire-resistant Crosslinked Polyethylene Cable	600V Class Rubber-insulated Cabtyre 400V Cable	Inverter Terminal		Motor Terminal	
					Input	Output		
200V	23P7	22	3.5	2.0	3.5	M5	M5	M4
	25P5	33	5.5	3.5	5.5	M5	M5	M5
	27P5	45	8.0	5.5	8.0	M5	M5	M5
	2011	66	14.0	14.0	14.0	M8	M8	M8
	2015	90	30.0	22.0	22.0	M8	M8	M8
	2018	111	38.0	22.0	28.0	M8	M8	M8
	2022	132	50.0	30.0	50.0	M8	M8	M8
	2030	180	—	50.0	—	M8	M8	M8
400V	43P7	11	2.0	2.0	2.0	M5	M5	M4
	45P5	16	2.0	2.0	2.0	M5	M5	M5
	47P5	22	3.5	2.0	3.5	M5	M5	M5
	4011	33	5.5	3.5	5.5	M8	M8	M8
	4015	45	8.0	5.5	8.0	M8	M8	M8
	4018	55	14.0	8.0	14.0	M8	M8	M8
	4022	66	14.0	14.0	22.0	M8	M8	M8
	4030	90	30.0	22.0	30.0	M8	M8	M8
Terminal Name					R, S, T, E	U, V, W, E	U, V, W, E	

Note : Cable size is selected at ambient temperature 30°C when built with 3-core 1-thread in the air.

The maximum allowable temperature of the conductor is 60°C for IV, VV and CT cables, and 110°C for 600V fire-resistant crosslinked polyethylene cables.

Precautions on Cable Selection at High Ambient Temperature

When ambient temperature exceeds 30°C, the cable allowable current is reduced. Select the cable size in accordance with the technical materials of the cable manufacturer based on rated current.

Table 12.2 Cooling Fan Motor Cable

Inverter	Cable	Terminal Name and Screw Size		
		Inverter Terminal		Motor Terminal
		Control Power Input	Cooling Fan Output	
200V	600V Class polyvinyl insulated wire, Size 2mm ²		M4	M4
400V		M4	M4	M4

13. CONNECTION TO TAPE READER

13.1 CONNECTION TO EACH UNIT

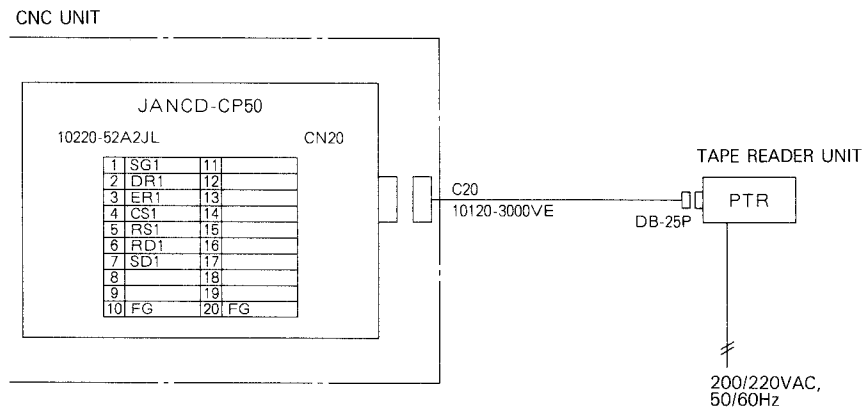
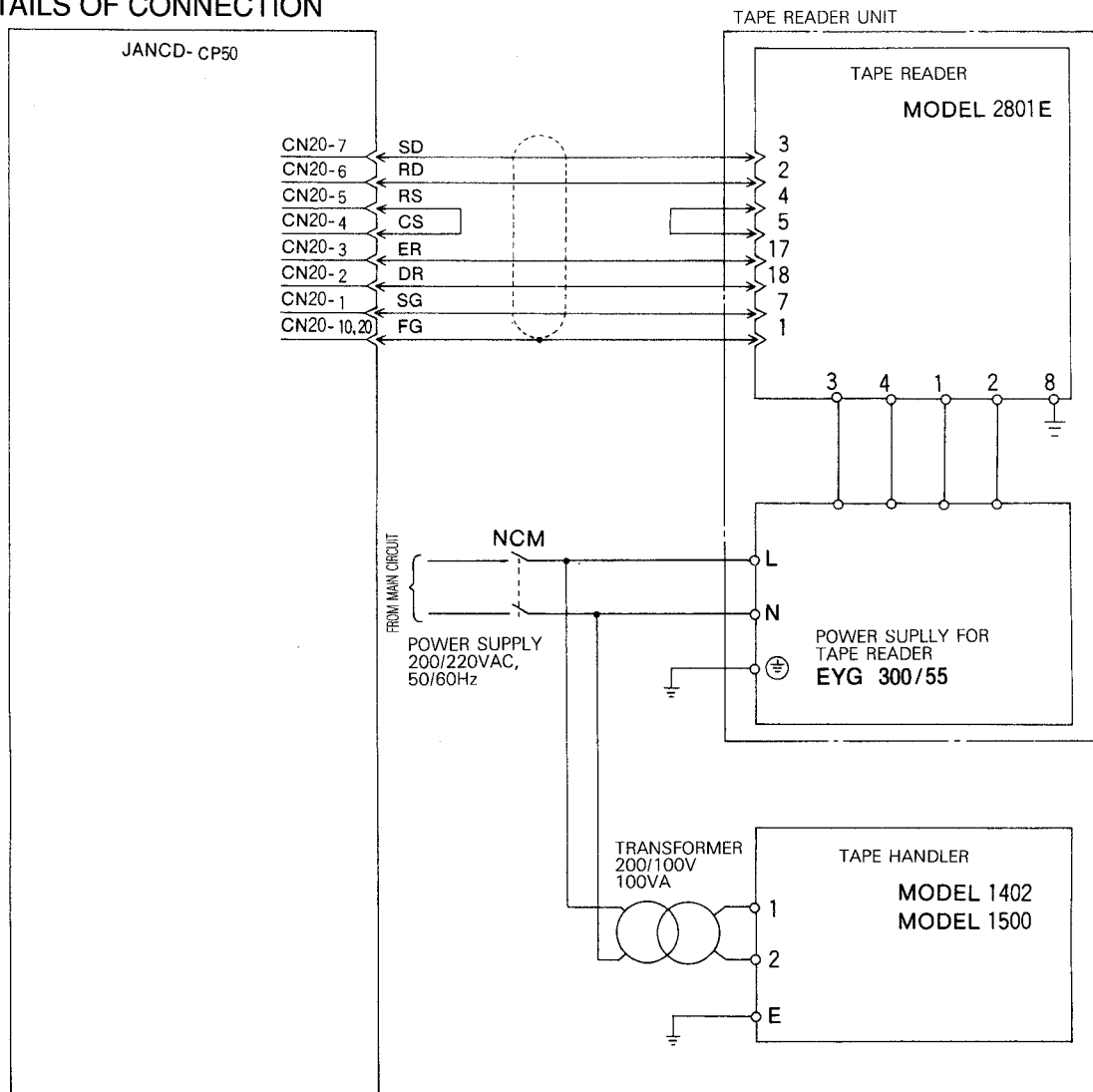

Fig. 13.1 Connection to Each Unit

13.2 DETAILS OF CONNECTION



Note : Wire length between tape reader and main board should be 3 m max.
For using the cable exceeding 3 m, contact your YASKAWA representative.

Fig. 13.2 Connection to Tape Reader

14. CONNECTION TO RS-232C INTERFACE

14.1 CONNECTION TO EACH UNIT

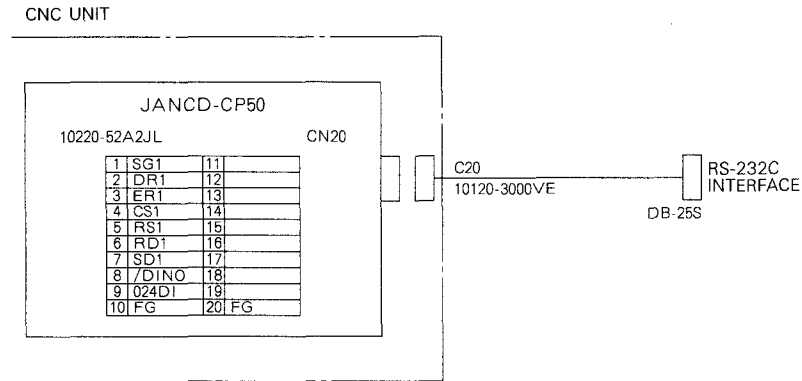

Fig. 14.1 Connection to Each Unit

14.2 DETAILS OF CONNECTION

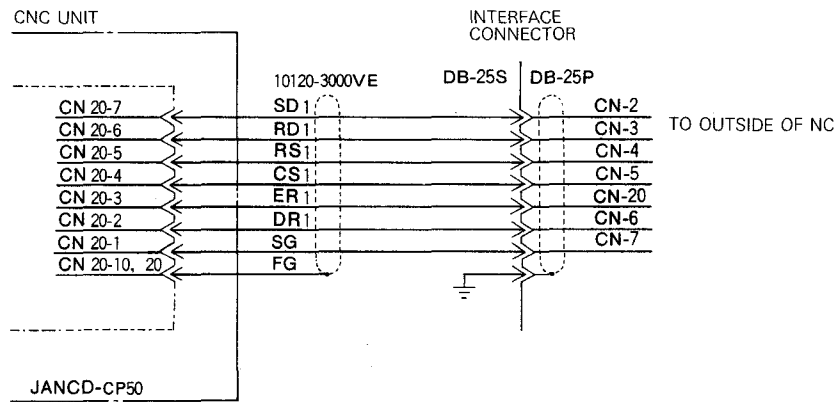

Fig. 14.2 Connection to RS-232C

14.3 RS-232C INTERFACE

(1) Transmission Mode

Start-stop synchronization: Each data bit is preceded by a start signal, and followed by a stop signal.

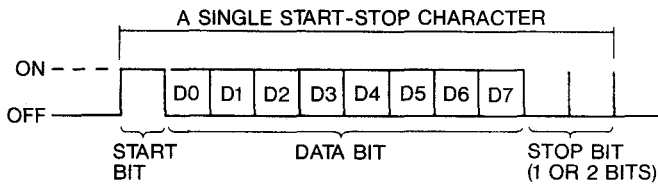

Table 14.1

	$V_0 < -3V$	$0_0 > +3V$
Function	OFF	ON
Signal Condition	Mark	Space
Logic	1	0

(2) Codes Used

The following two types of codes are used, and are selectively used by parameters (#6026D5, #6028D5).

- EIA codes or ISO codes
- EIA codes or ISO codes + control codes (DC1 - DC4)

To use control codes, the machine to be controlled must be able to discriminate codes DC1 through DC4. Codes DC1 - DC4 are as follows.

Table 14.2

Character		8	7	6	5	4	Feed Hole	3	2	1
DC1	Tape reader start				○					○
DC2	Tape reader punching				○				○	
DC3	Tape reader stop	○			○				○	○
DC4	Tape punch release				○			○		

(3) Transmission Baud Rate

Transmission baud rates can be selected at any rate between 50 and 9600 bauds with parameters.

Refer to (7) in Par. 14.2.

(4) Cable Length

The permissible maximum cable length varies with the machine to be controlled. Refer to the machine builder's manual. (Standard maximum cable length is 15 m.)

(5) Interconnection

Table 14.3 RS-232C Interface Connecting Cable (A)

NC (DB-25P)			Connections	External Equipment
Symbol	Signal Name	Pin No.		Symbol
FG	Frame grounding	1	○ — ○	FG
SD	Sending data	2	○ — ○	SD
RD	Receiving data	3	○ — ○	RD
RS	Sending data	4	○ — ○	RS
CS	Capable of sending	5	○ — ○	CS
DR	Data set ready	6	○ — ○	DR
SG	Signal grounding	7	○ — ○	SG
ER	Data terminal ready	20	○ — ○	IO BUSY
			○ — ○	ER

NC outputs control codes DC1 - DC4 to start and stop the machine, but the machine can not output control codes to control the NC. However, when the machine under control is unable to process data in time, it can control the CS signals of the NC to halt the data outputting of the NC.

When CS signals of the NC are not used, short CS and RS as shown Table 14.4.

Table 14.4 RS-232C Interface Connecting Cable (B)

NC (DB-25P)			Connections	External Equipment
Symbol	Signal Name	Pin No.		Symbol
FG	Frame grounding	1	○ — ○	FG
SD	Sending data	2	○ — ○	SD
RD	Receiving data	3	○ — ○	RD
RS	Sending data	4	○ — ○	RS
CS	Capable of sending	5	○ — ○	CS
DR	Data set ready	6	○ — ○	DR
SG	Signal grounding	7	○ — ○	SG
ER	Data terminal ready	20	○ — ○	ER (OR IO ARARM)

· Description of signals

FG : Safety grounding

SD : Transmission data (output)

RD : Received data (input)

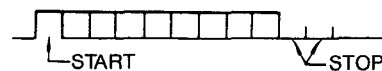

RS: Request for sending (output) – When sending data, NC is turned ON when starting transmission, and turned OFF when transmission ends.

CS: For sending (input) – When this input signal is ON, NC can send data. If the machine under control is unable to process data in time, it can turn OFF this signal to interrupt the transmission of data from NC within 2 characters. When this signal is not used, connect lines as shown in Table 14.4.

SG: Signal grounding.

ER: Data terminal ready – Use this signal as a tape rewinding signal if a tape reader is connected to an RS-232C interface. The tape reader can be rewound if this signal is ON.

NOTE

Among the RS-232C interface signals, the following are normally not used by the NC.

DR: Data set ready

ER: Data terminal ready

CD: Data receiving carrier detection

However, when “1” is set for parameter CHKDR (#6021 D4), a DR (data set ready) interlock is added.

(6) Signal Exchange Timing

· When NC receives data.

Data can be received in the following sequence and timing.

- (a) NC sends code DC1.
- (b) At code DC1, the machine under control starts to send data to NC.
- (c) If the NC can not process data in time, it sends out code DC3.
- (d) At code DC3, the machine stops sending data within 10 characters.
- (e) NC again sends code DC1 after processing data.
- (f) At code DC1, the machine sends out the data that succeeds the previously sent one.
- (g) Upon reading in the data, NC sends out code DC3.
- (h) The machine stops sending data.

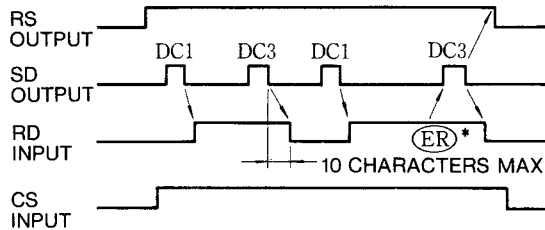

Fig. 14.3

* (ER) represents “rewind stop code”, which is the same as “%” of ISO.

· When NC sends out data

NC sends out data in the following sequence and timing.

- (a) NC sends out code DC2, and subsequently sends out data.
- (b) If the machine under control can not process the data in time, NC stops CS at no IO BUSY signal.
- (c) Upon completion of the data processing by the machine, NC turns on CS. NC sends out data that succeeds the previous one.
- (d) Upon completion of data sending, NC sends out code DC4.

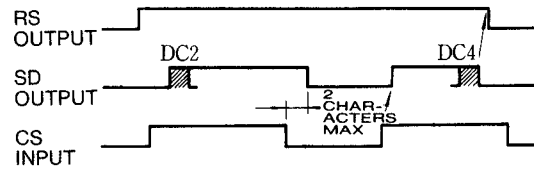

Fig. 14.4

NOTE

DC1 and DC3 code from RD is not available when NC sends out data.

(7) Parameter Setting

When using RS-232C, set data transmission baud rates, stop bit lengths, and control code sending specifications with the parameters shown in Table 14.6.

(a) RS-232C interface port selection

Select the RS-232C interface port by setting #6003.

Table 14.5 RS-232C Interface Port Selection

Interface	Input	Output
RS-232C Port 1	#6003D0	#6003D4

Note: The above bit is selected at parameter setting “1”

(b) RS-232C interface port 1

Baud rate setting of RS-232C interface port 1 is shown in Table 14.6.

Table 14.6 Baud Rate Setting

Baud Rate Values	Input	# 6026D3	# 6026D2	# 6026D1	# 6026D0
	Output	# 6028D3	# 6028D2	# 6028D1	# 6028D0
50	0	0	0	0	0
100	0	0	0	1	0
110	0	0	1	0	0
150	0	0	1	1	1
200	0	1	0	0	0
300	0	1	0	1	1
600	0	1	1	1	0
1200	0	1	1	1	1
2400	1	0	0	0	0
4800	1	0	0	0	1
9600	1	0	1	1	0

14.3 RS-232C INTERFACE (Cont'd)

- Stop bit length setting
 - # 6026 D4 for input 1: Sets stop bit at two bits.
 - # 6028 D4 for output 0: Sets stop bit at one bit.
- Setting of control code sending
 - # 6026 D5 for input 1: Does not send control code.
 - # 6028 D5 for output 0: Sends control code.

15. DIRECT-IN SIGNAL CONNECTION

15.1 CONNECTION TO EACH UNIT

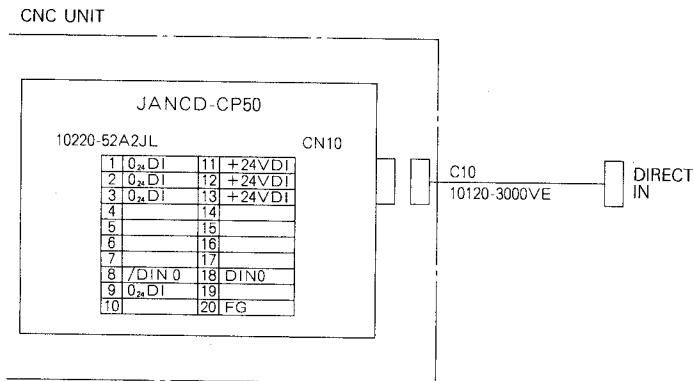

Fig. 15.1

15.2 DETAILS OF CONNECTION

The following input signals require high-speed processing and are connected to the PC board (type JANCD-PC50), instead of general-purpose I/O boards.

These signals are processed directly by the NC main processing unit without coursing through the PC.

DINO: Skip input

Direct-in signal connection is shown in Fig. 15.1 and 15.2.

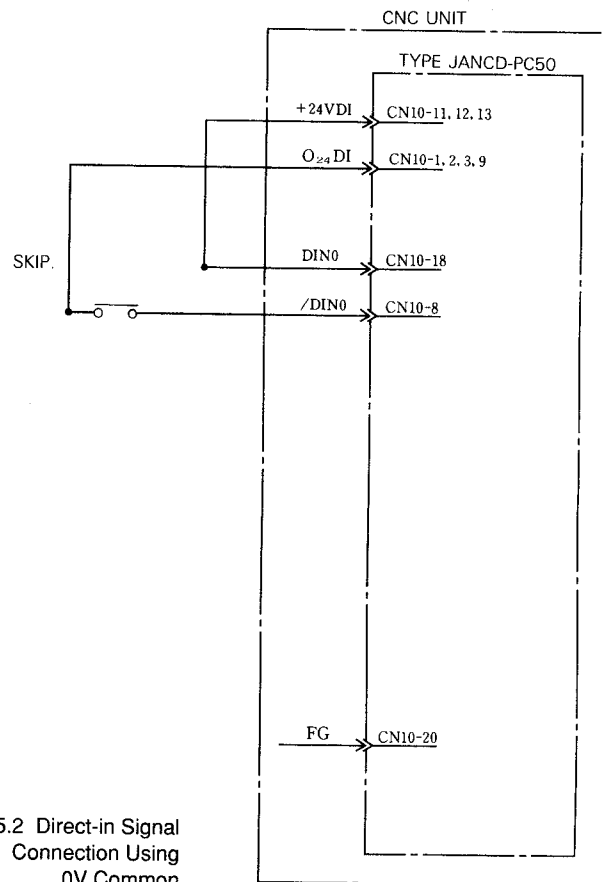

Fig. 15.2 Direct-in Signal Connection Using 0V Common

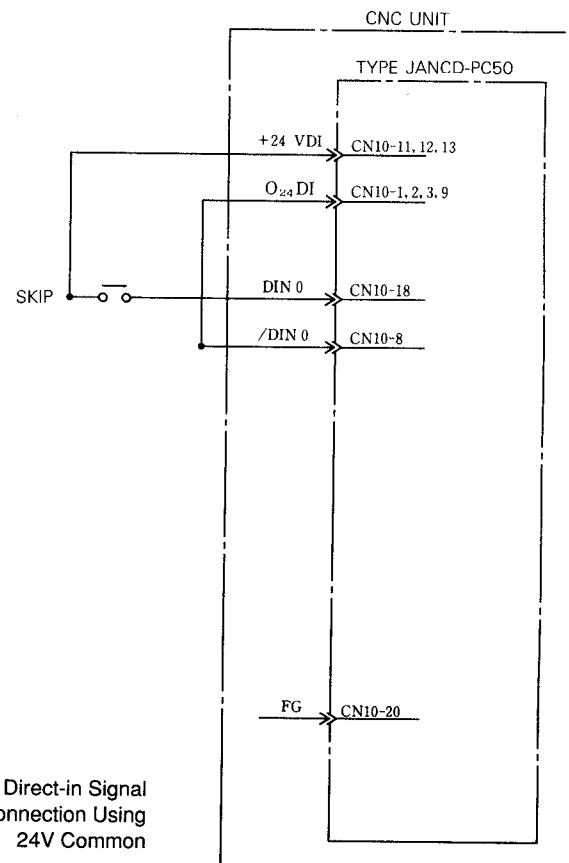

Fig. 15.3 Direct-in Signal Connection Using 24V Common

15.3 DETAILS OF SIGNALS

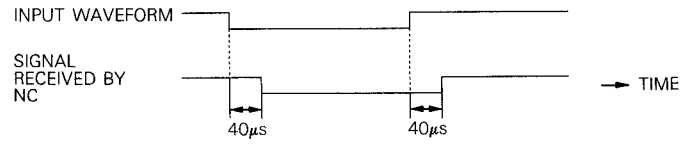

Fig. 15.4 Time Chart

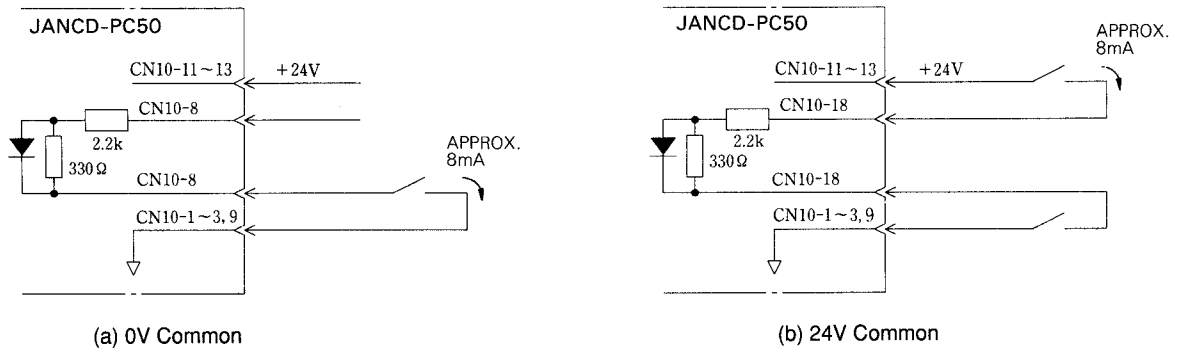

Fig. 15.5 I/O Circuit

16. CONNECTION TO GENERAL-PURPOSE I/O SIGNALS

16.1 CONNECTION TO EACH UNIT

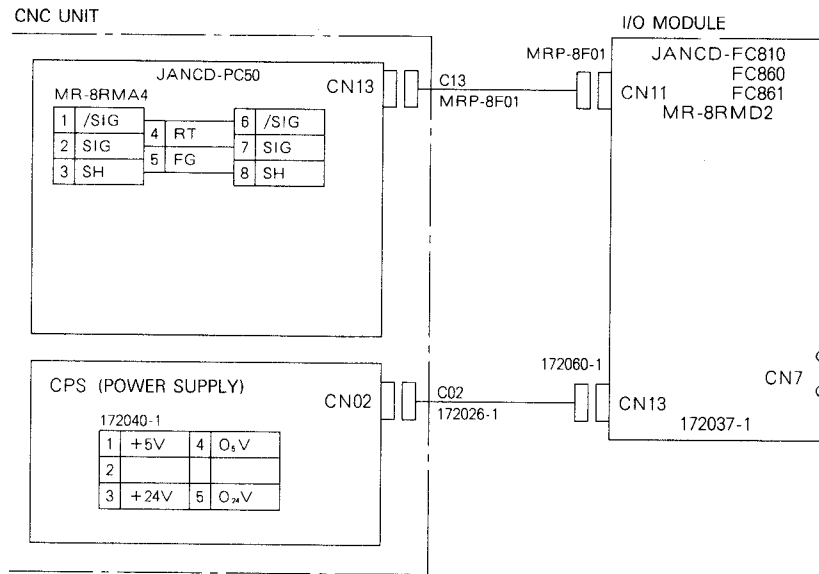

Fig. 16.1

16.2 DETAILS OF CONNECTION

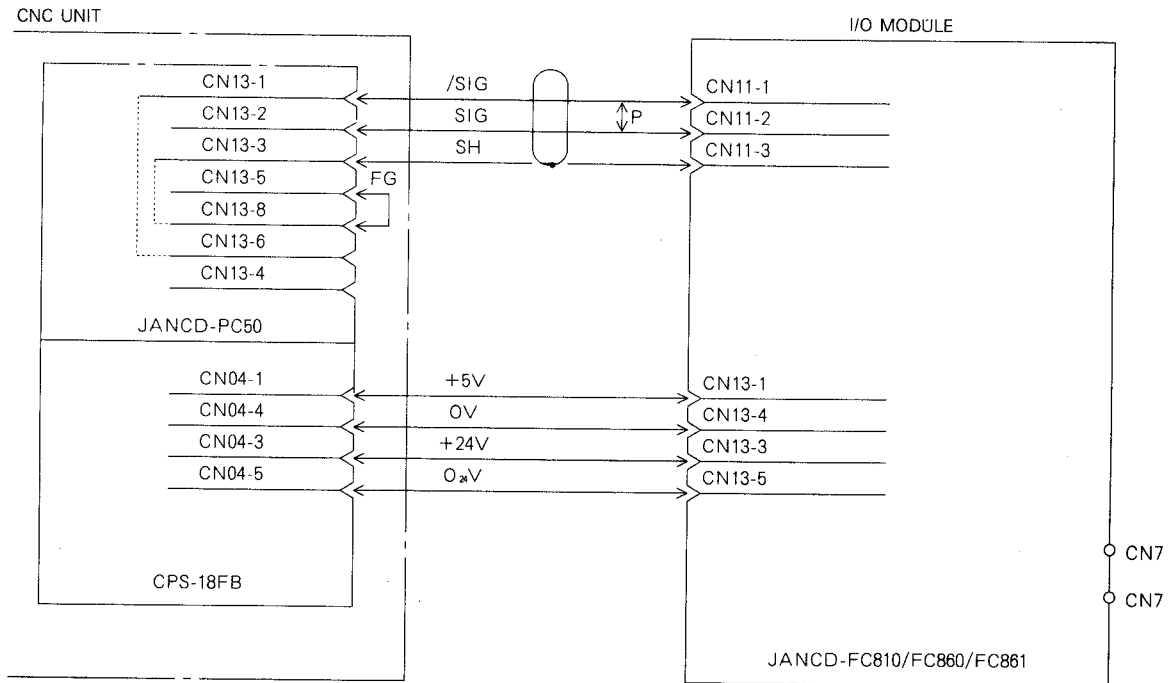

Fig. 16.2 Connection to General-purpose I/O Signal

16.3 CONNECTION TO ADDITIONAL GENERAL-PURPOSE I/O SIGNALS

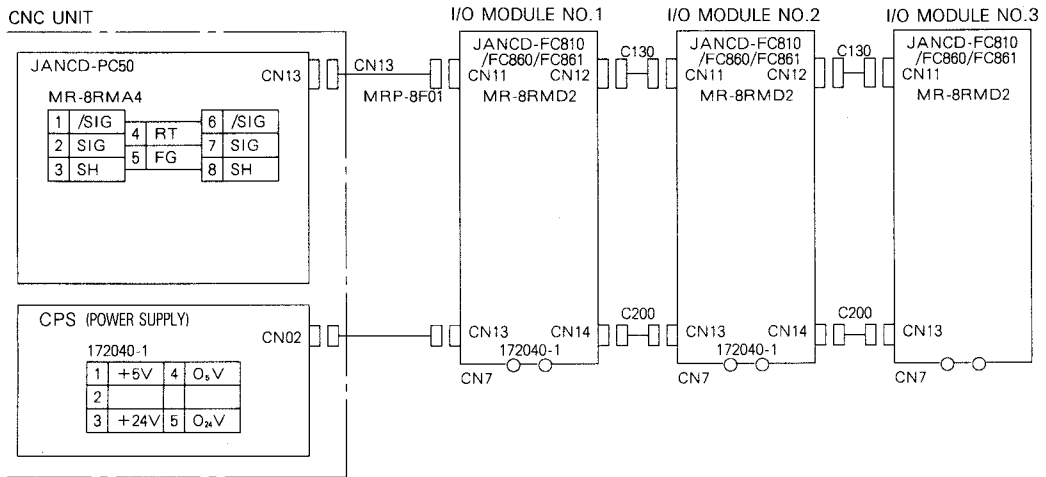

Fig. 16.3

16.4 DETAILS OF CONNECTION

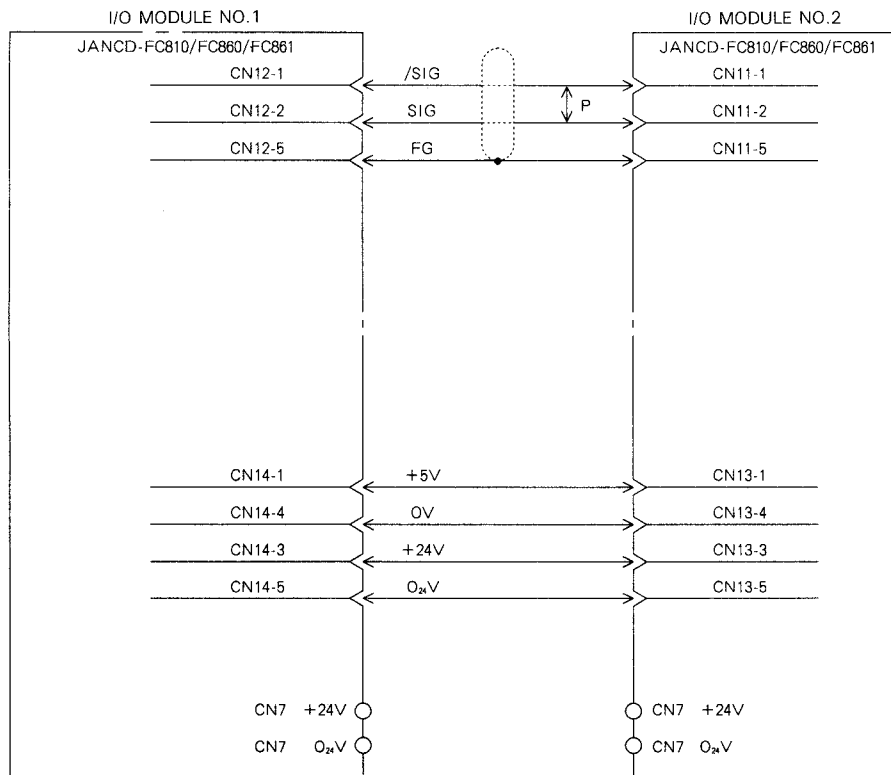
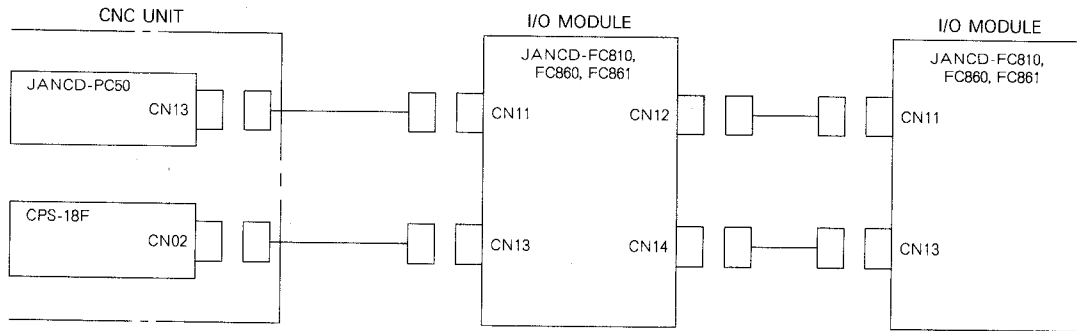

Fig. 16.4 Connection to Additional General-purpose I/O Signal

Notes:

1. Up to 3 general-purpose I/O modules can be connected (when FC810 or F860 is used.)
2. It is necessary to terminate the final module since another general-purpose I/O module can be added.

<Example>



NO.1 SETTING
TERMINATION (SW 3)
ON/OFF

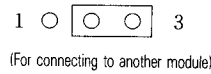

NO.2 SETTING
TERMINATION (SW 3)
ON/OFF

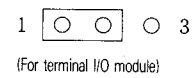

3. Logic can be set to "1" by short-pin SW2 setting of an I/O module (FC810, FC860, FC861) when the input contact is "closed" disregarding whether common 0V or 24V is used.

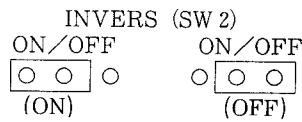

4. I/O port I/O addresses of an I/O module can be set by rotary switch (SW1).

Positions of TERMINATION, INVERS, and ADDRESS switches

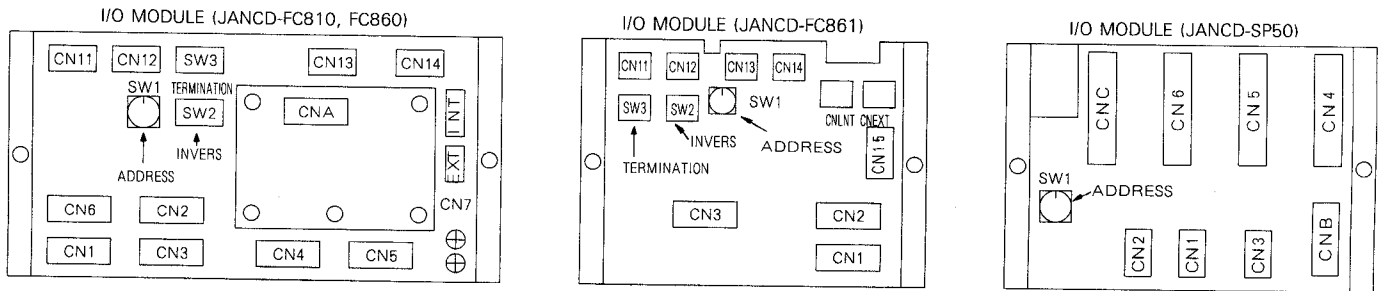

17. CONNECTION TO GENERAL-PURPOSE I/O

17.1 CONNECTION TO EACH UNIT

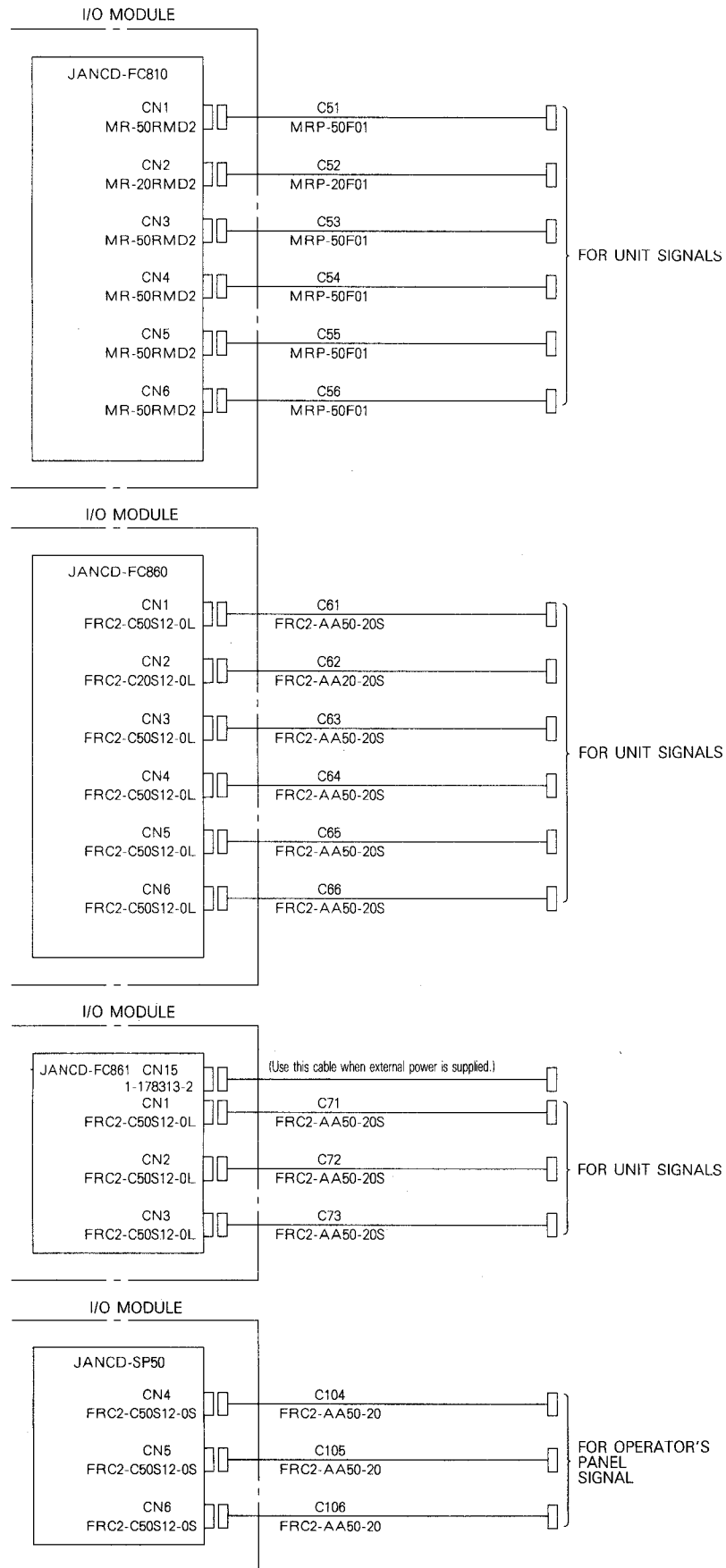
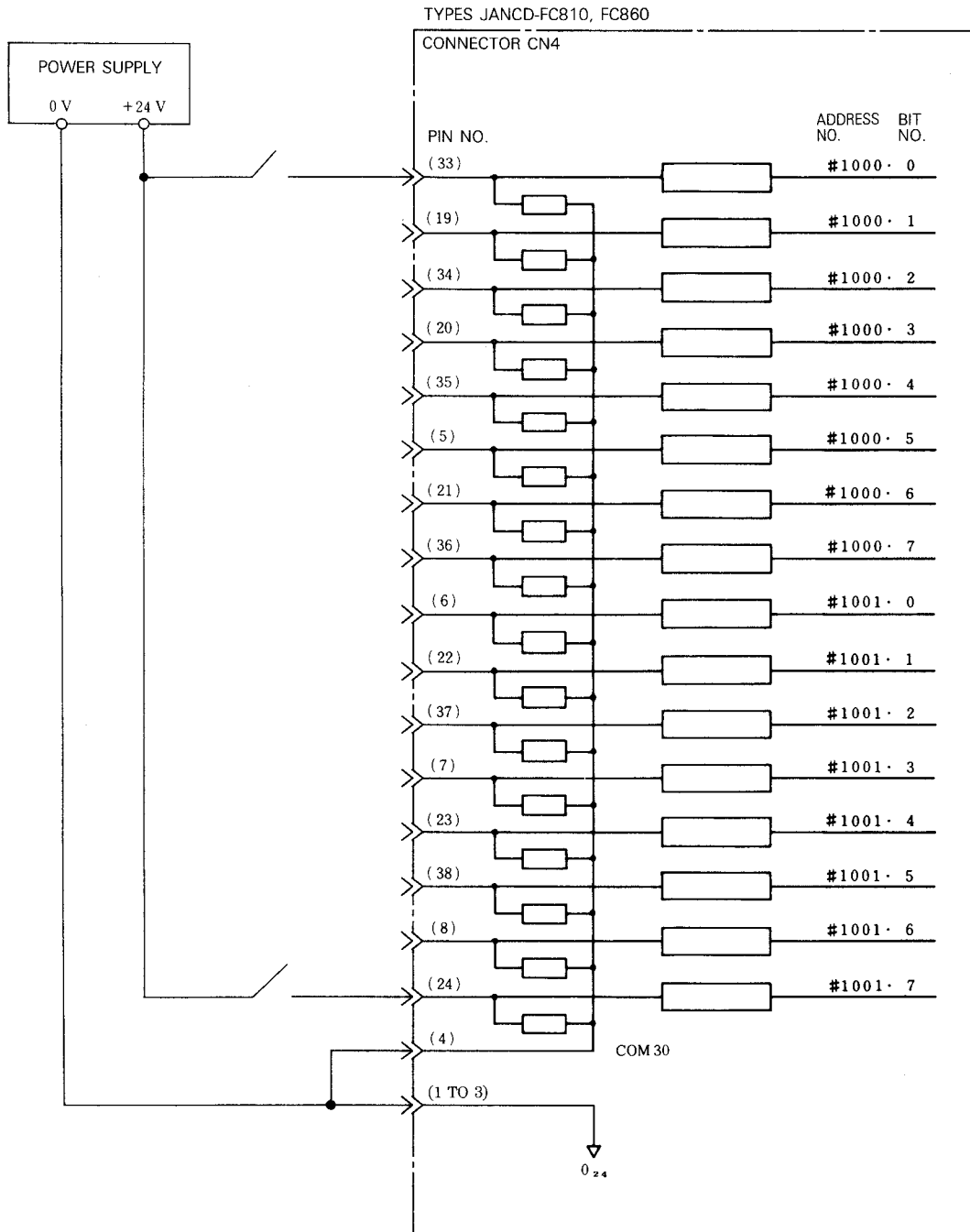

Fig. 17.1

17.2 DETAILS OF CONNECTION

17.2.1 FC810/FC860 MODULE



Notes :

1. This connection example shows +24 V common.
0 V common is also available. Refer to Par. 18.3.2.1 I/O Module Types JANCD-FC810/FC860 for connection details.
2. The addresses are those for module No.1. The address layouts for modules Nos. 2 and 3 are the same as shown above starting with newer addresses. Refer to Appendix B (3), Address Classification for details.

Fig. 17.2 Connection to Address and Bit Nos.
#1000.0 to #1001.7 on FC810/FC860 Modules

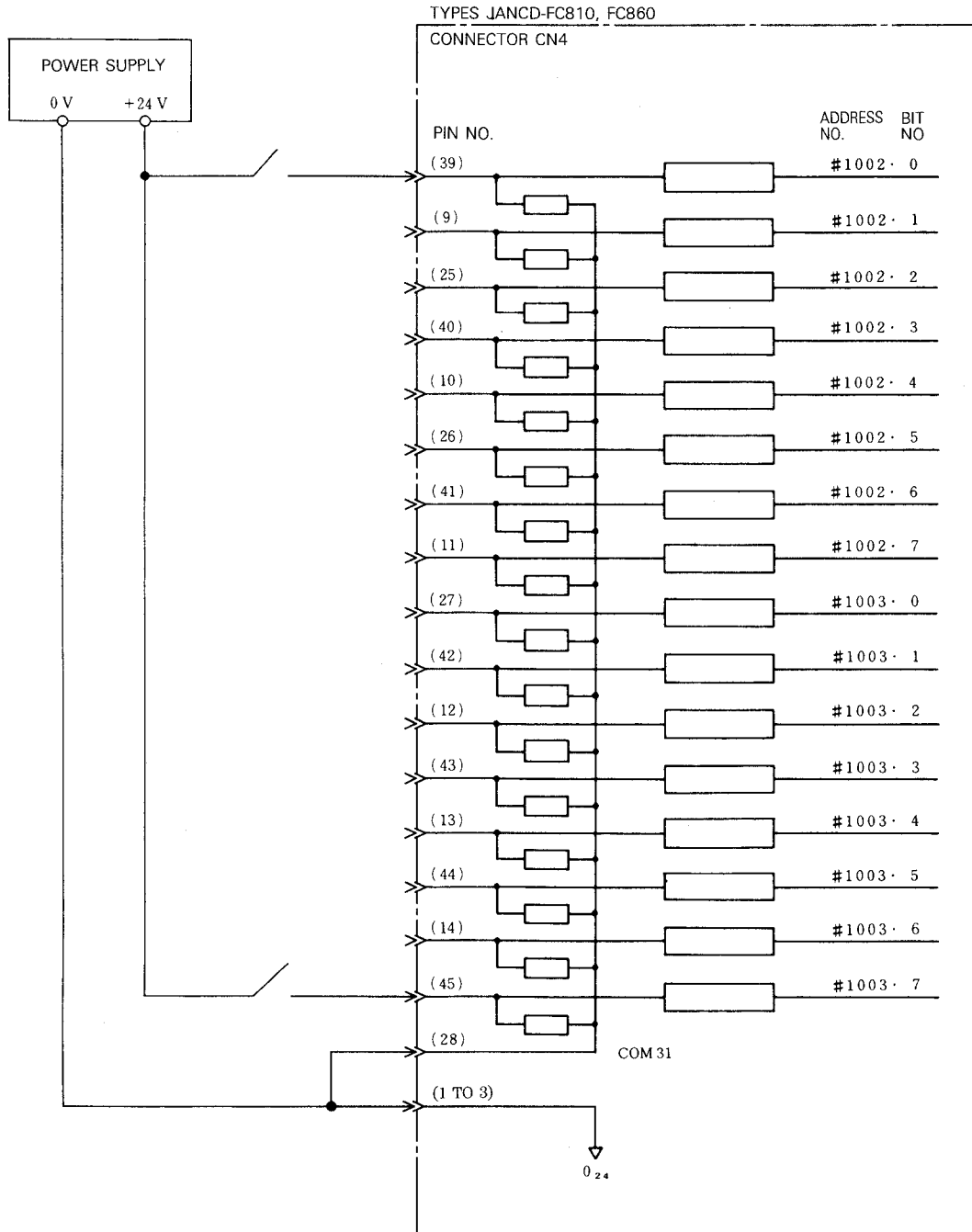

Notes :

1. This connection example shows +24 V common.
0 V common is also available. Refer to Par. 18.3.2.1, I/O Module Types JANCD-FC810/FC860 for connection details.
2. The addresses are those for module No.1. (#1002.0 to #1003.7). The address layouts for modules Nos. 2 and 3 are the same as shown above starting with newer addresses. Refer to Appendix B (3), Address Classification for details.

Fig. 17.3 Connection to Address and Bit Nos.
#1002.0 to #1003.7 on FC810/FC860 Modules

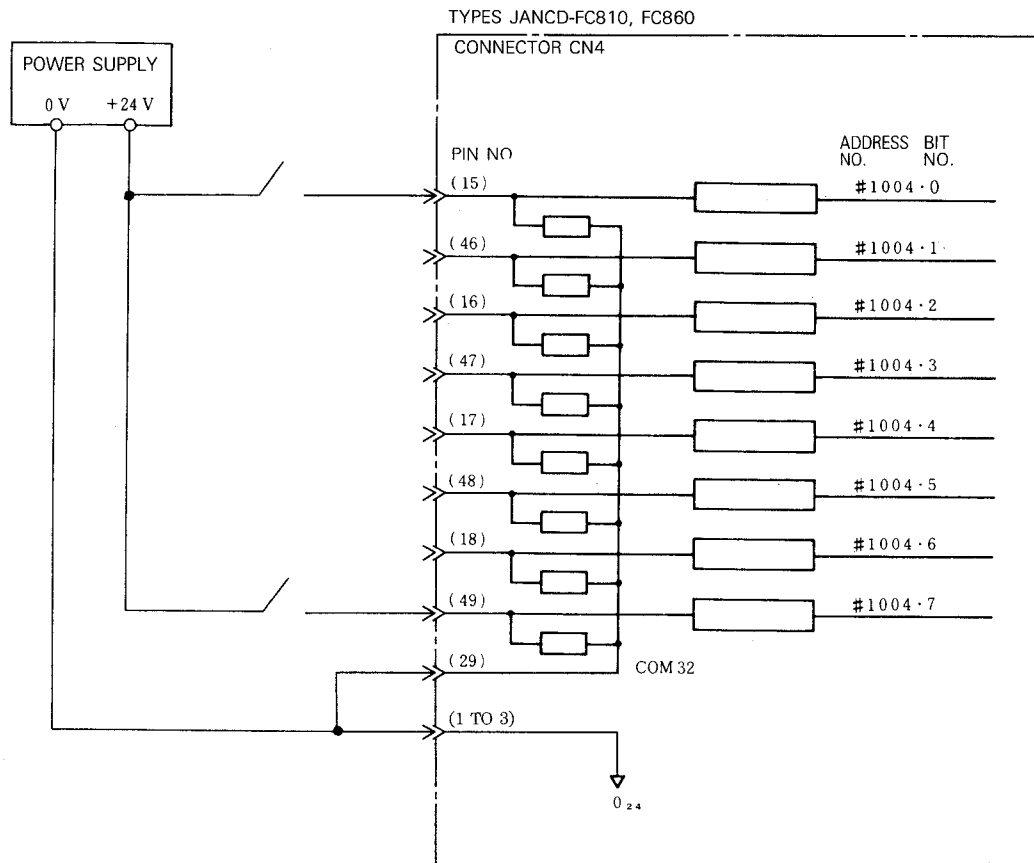

Notes :

1. This connection example shows +24 V common.
0 V common is also available. Refer to Par. 18.3.2.1, I/O Module Types JANCD-FC810/FC860 for connection details.
2. The addresses are those for module No.1. (#1004.0 to #1004.7). The address layouts for modules Nos. 2 and 3 are the same as shown above starting with newer addresses. Refer to Appendix B (3), Address Classification for details.

Fig. 17.4 Connection to Address and Bit Nos. #1004.0 to #1004.7 on FC810/FC860 Modules

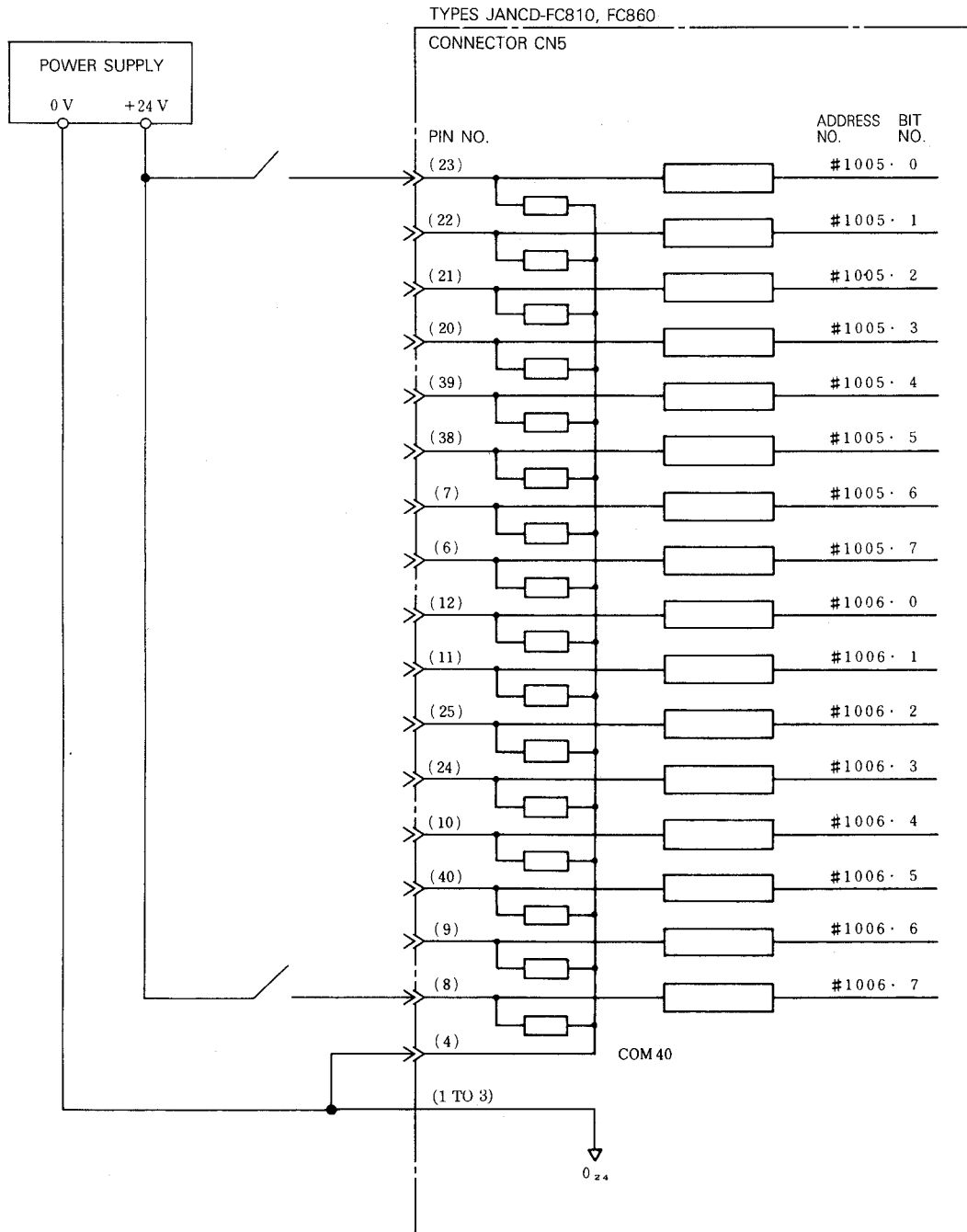

Notes :

1. This connection example shows +24 V common.
0 V common is also available. Refer to Par. 18.3.2.1, I/O Module Types JANCD-FC810/FC860 for connection details.
2. The addresses are those for module No.1. (#1005.0 to #1006.7). The address layouts for modules Nos. 2 and 3 are the same as shown above starting with newer addresses. Refer to Appendix B (3), Address Classification for details.

Fig. 17.5 Connection to Address and Bit Nos. #1005.0 to #1006.7 on FC810/FC860 Modules

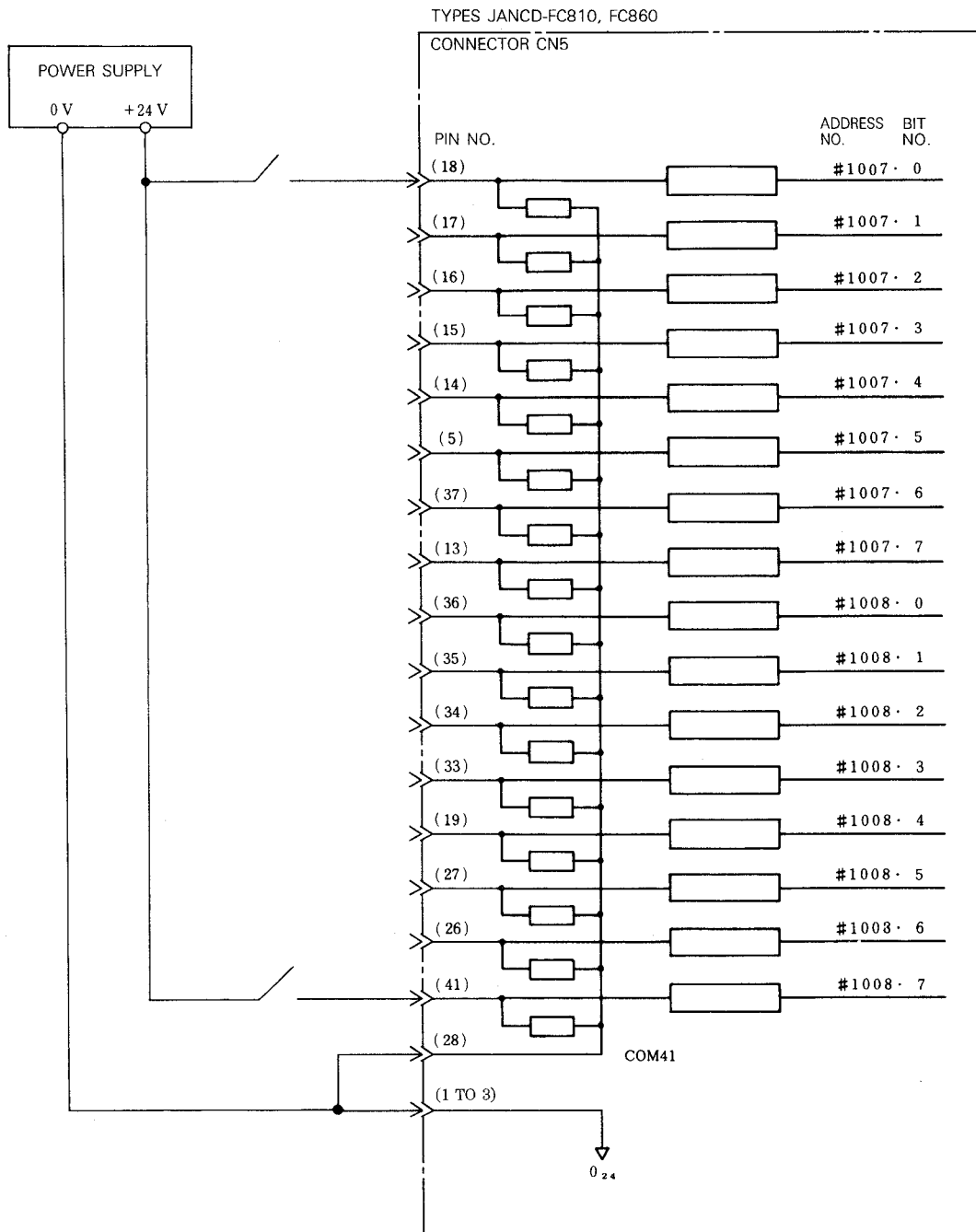

Notes :

1. This connection example shows +24 V common.
0 V common is also available. Refer to Par. 18.3.2.1, I/O Module Types JANCD-FC810/FC860 for connection details.
2. The addresses are those for module No.1. (#1007.0 to #1008.7). The address layouts for modules Nos. 2 and 3 are the same as shown above starting with newer addresses. Refer to Appendix B (3), Address Classification for details.

Fig. 17.6 Connection to Address and Bit Nos. #1007.0 to #1008.7 on FC810/FC860 Modules

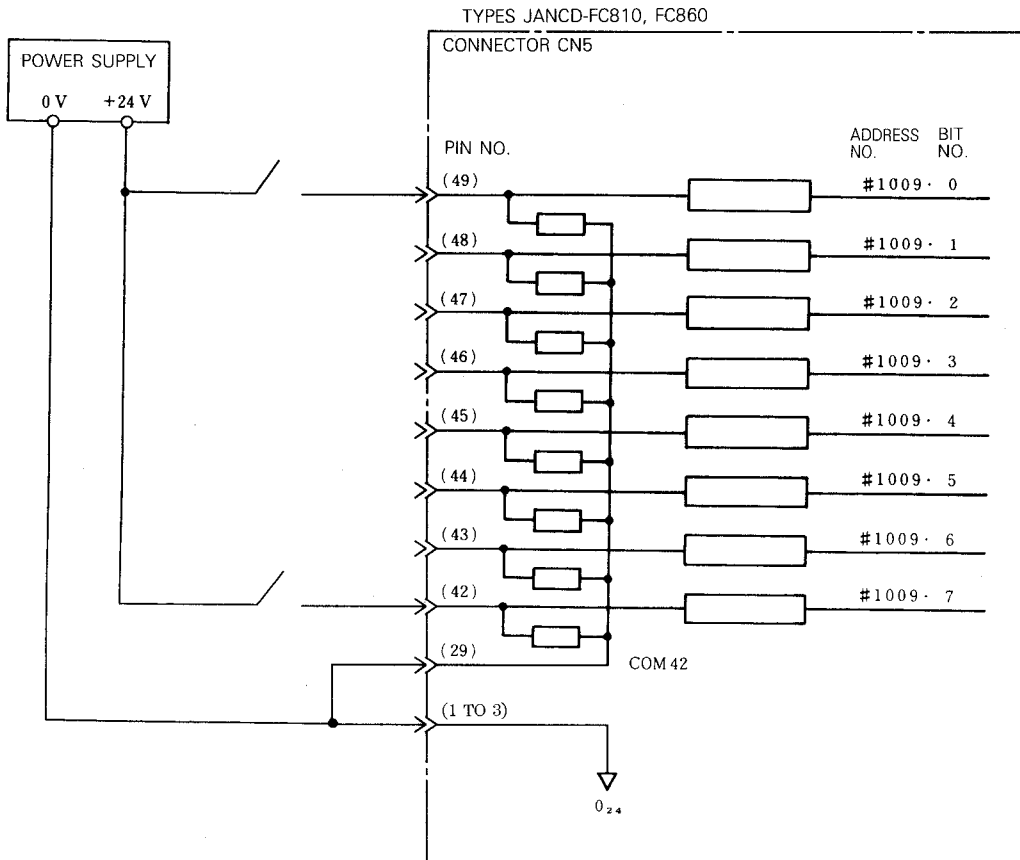

Notes :

1. This connection example shows +24 V common.
0 V common is also available. Refer to Par. 18.3.2.1, I/O Module Types JANCD-FC810/FC860 for connection details.
2. The addresses are those for module No.1. (#1009.0 to #1009.7). The address layouts for modules Nos. 2 and 4 are the same as shown above starting with newer addresses. Refer to Appendix B (3), Address Classification for details.

Fig. 17.7 Connection to Address and Bit Nos.
#1009.0 to #1009.7 on FC810/FC860 Modules

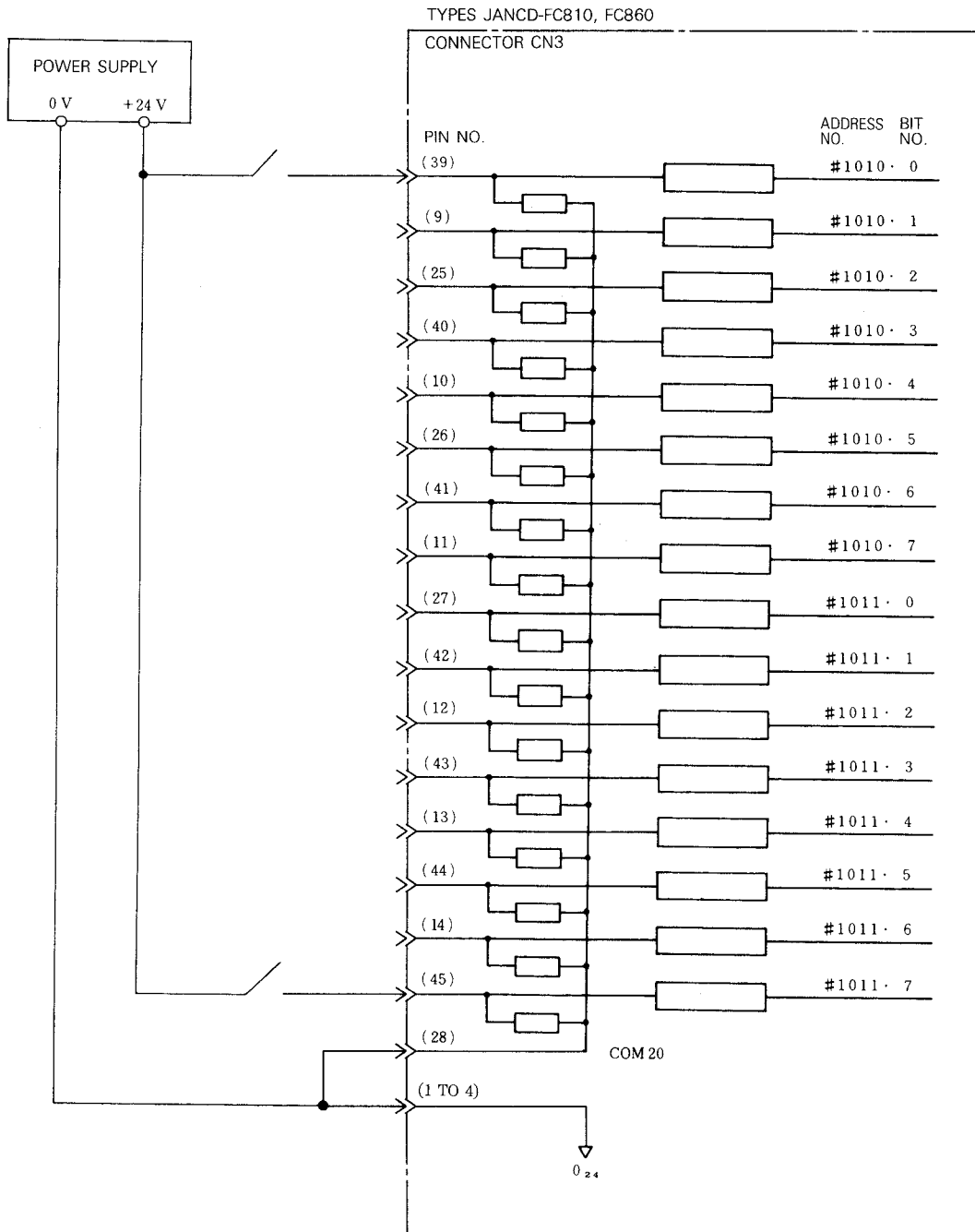

Notes :

1. This connection example shows +24 V common.
0 V common is also available. Refer to Par. 18.3.2.1, I/O Module Types JANCD-FC810/FC860 for connection details.
2. The addresses are those for module No.1. (#1010.0 to #1011.7). The address layouts for modules Nos. 2 and 3 are the same as shown above starting with newer addresses. Refer to Appendix B (3), Address Classification for details.

Fig. 17.8 Connection to Address and Bit Nos.
#1010.0 to #1011.7 on FC810/FC860 Modules

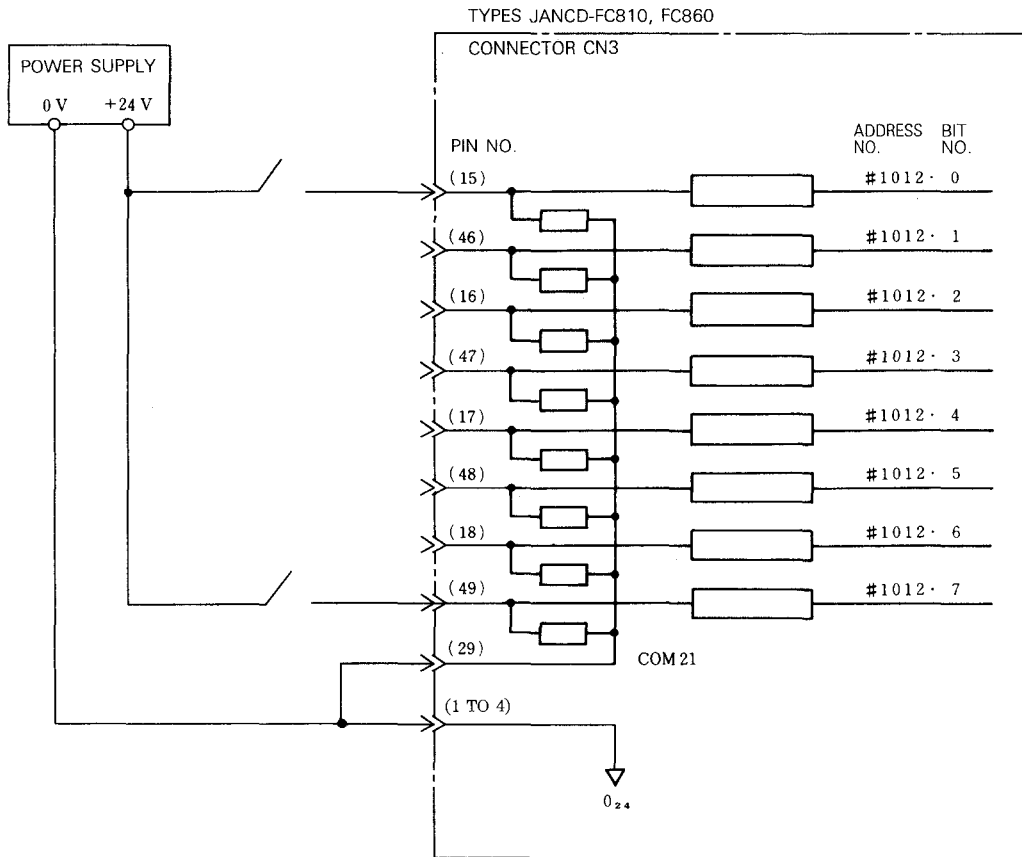

Notes :

1. This connection example shows +24 V common.
0 V common is also available. Refer to Par. 18.3.2.1, I/O Module Types JANCD-FC810/FC860 for connection details.
2. The addresses are those for module No.1. (#1012.0 to #1012.7). The address layouts for modules Nos. 2 and 3 are the same as shown above starting with newer addresses. Refer to Appendix B (3), Address Classification for details.

Fig. 17.9 Connection to Address and Bit Nos.
#1012.0 to #1012.7 on FC810/FC860 Modules

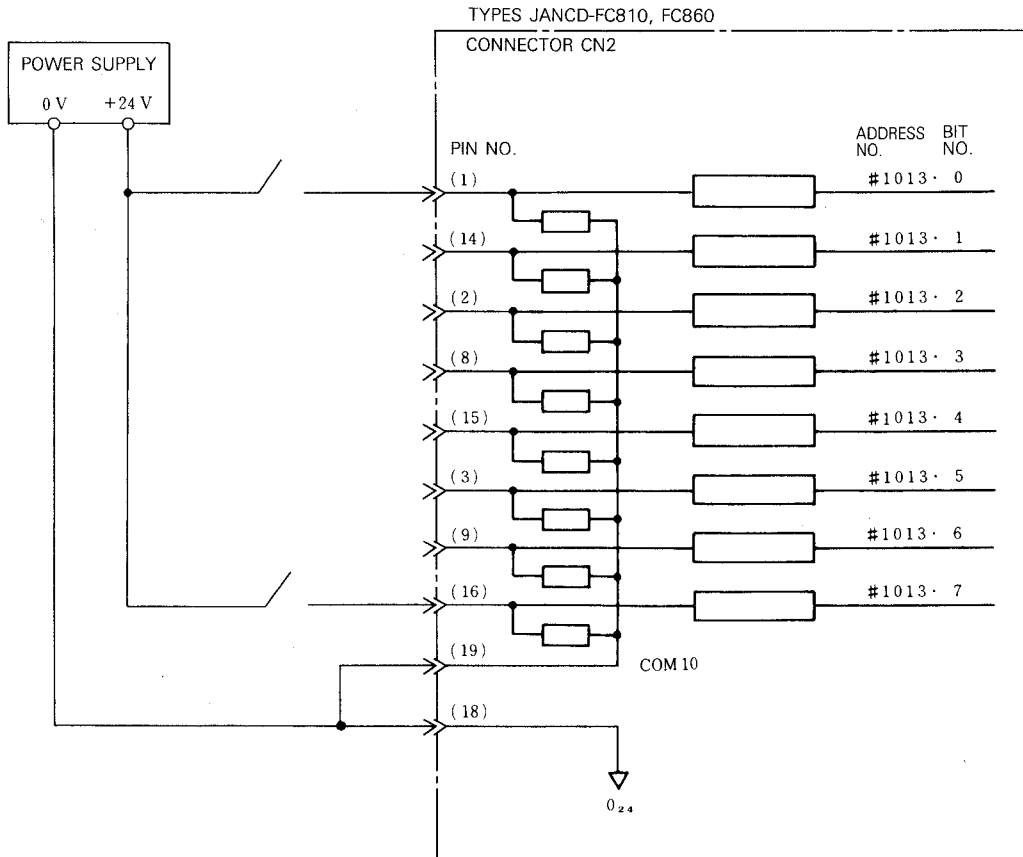

Notes :

1. This connection example shows +24 V common.
0 V common is also available. Refer to Par. 18.3.2.1, I/O Module Types JANCD-FC810/FC860 for connection details.
2. The addresses are those for module No.1. (#1013.0 to #1013.7). The address layouts for modules Nos. 2 and 3 are the same as shown above starting with newer addresses. Refer to Appendix B (3), Address Classification for details.

Fig. 17.10 Connection to Address and Bit Nos.
#1013.0 to #1013.7 on FC810/FC860 Modules

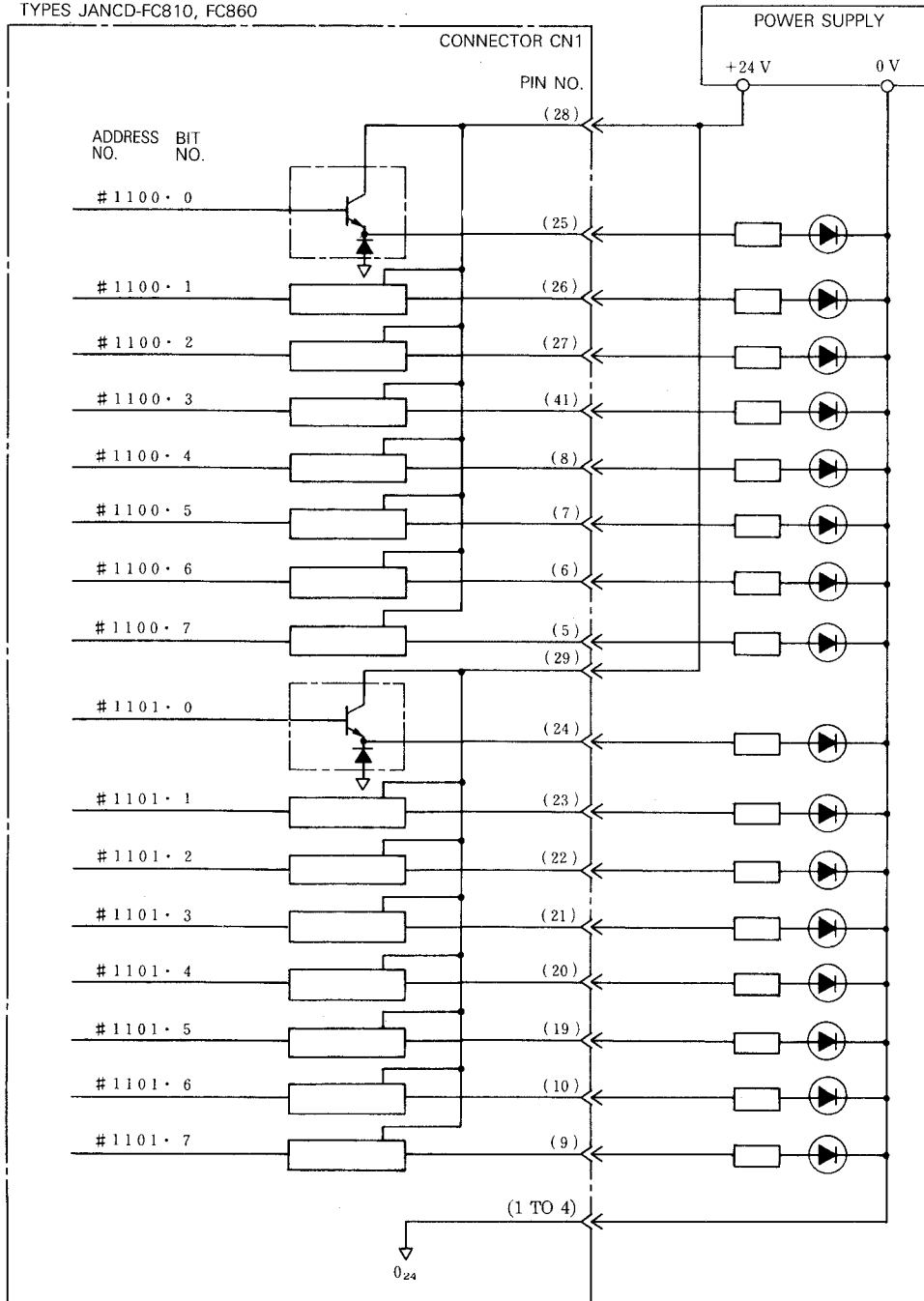

Note :

The addresses are those for module No.1. (#1100.0 to #1101.7). The address layouts for modules Nos. 2 and 3 are the same as shown above starting with newer addresses. Refer to Appendix B (3), Address Classification for details.

Fig. 17.11 Connection to Address and Bit Nos. #1100.0 to #1101.7 on FC810/FC860 Modules

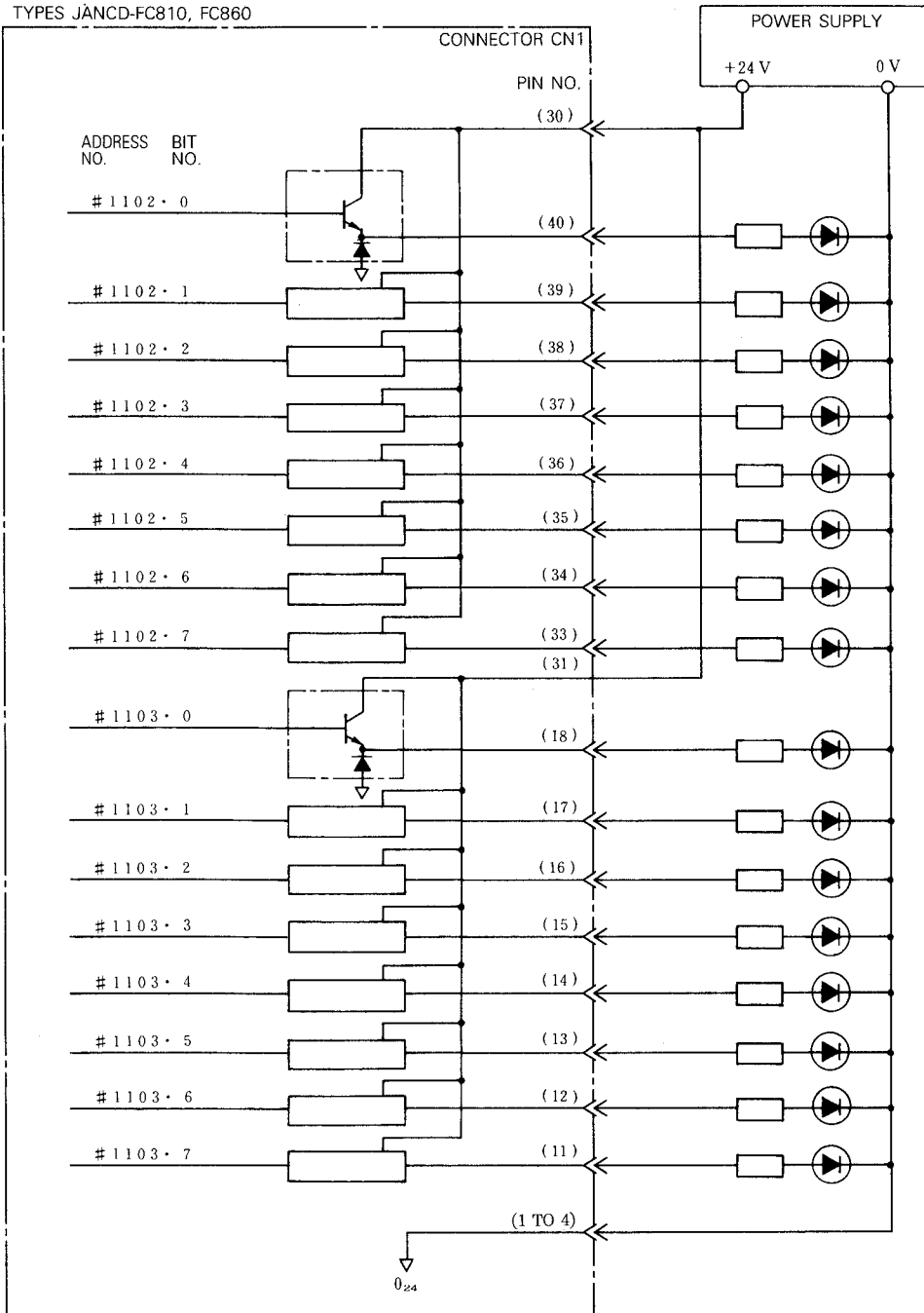

Note :

The addresses are those for module No.1. (#1102.0 to #1103.7). The address layouts for modules Nos. 2 and 3 are the same as shown above starting with newer addresses. Refer to Appendix B (3), Address Classification for details.

Fig. 17.12 Connection to Address and Bit Nos.
#1102.0 to #1103.7 on FC810/FC860 Modules

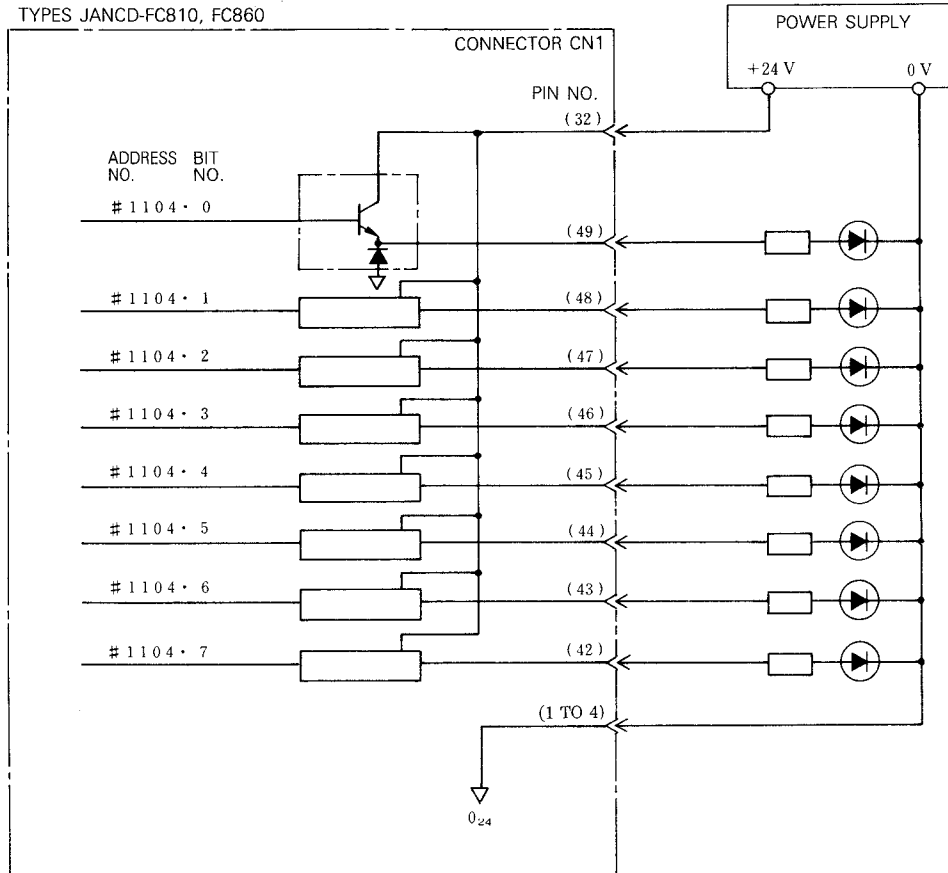

Note :

The addresses are those for module No.1. (#1104.0 to #1104.7). The address layouts for modules Nos. 2 and 3 are the same as shown above starting with newer addresses. Refer to Appendix B (3), Address Classification for details.

Fig. 17.13 Connection to Address and Bit Nos.
#1104.0 to #1104.7 on FC810/FC860 Modules

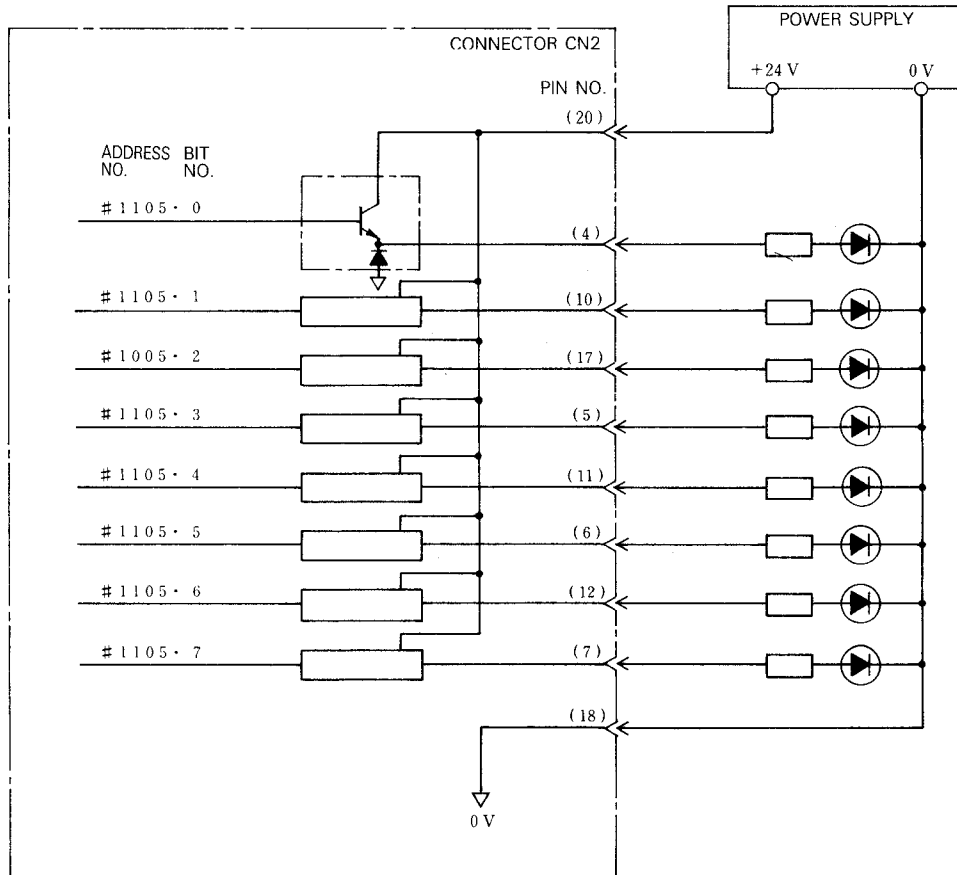

Note :

The addresses are those for module No.1. (#1105.0 to #1105.7). The address layouts for modules Nos. 2 and 3 are the same as shown above starting with newer addresses. Refer to Appendix B (3), Address Classification for details.

Fig. 17.14 Connection to Address and Bit Nos.
#1105.0 to #1105.7 on FC810/FC860 Modules

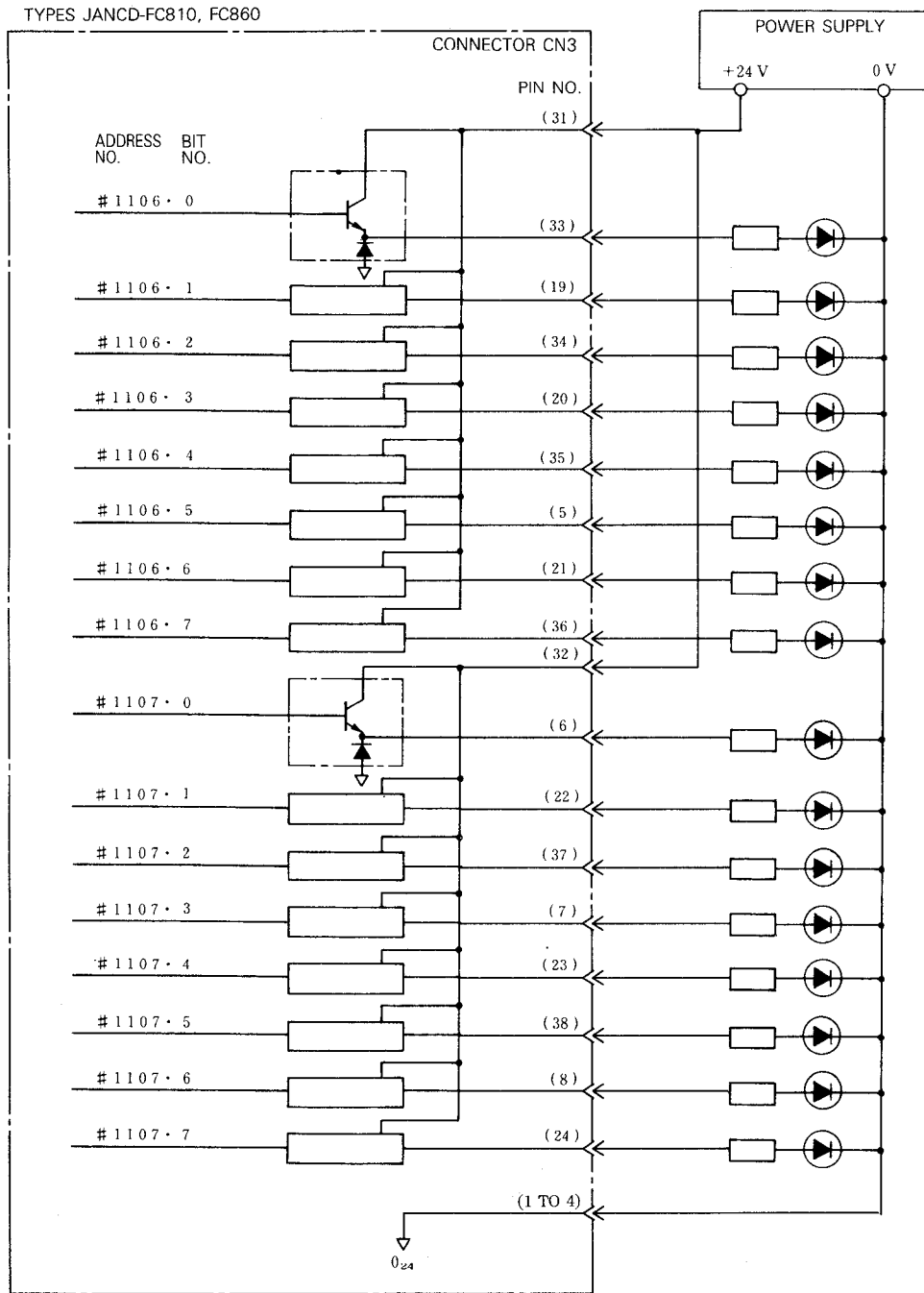

Note :

The addresses are those for module No.1. (#1106.0 to #1107.7). The address layouts for modules Nos. 2 and 3 are the same as shown above starting with newer addresses. Refer to Appendix B (3), Address Classification for details.

Fig. 17.15 Connection to Address and Bit Nos.
#1106.0 to #1107.7 on FC810/FC860 Modules

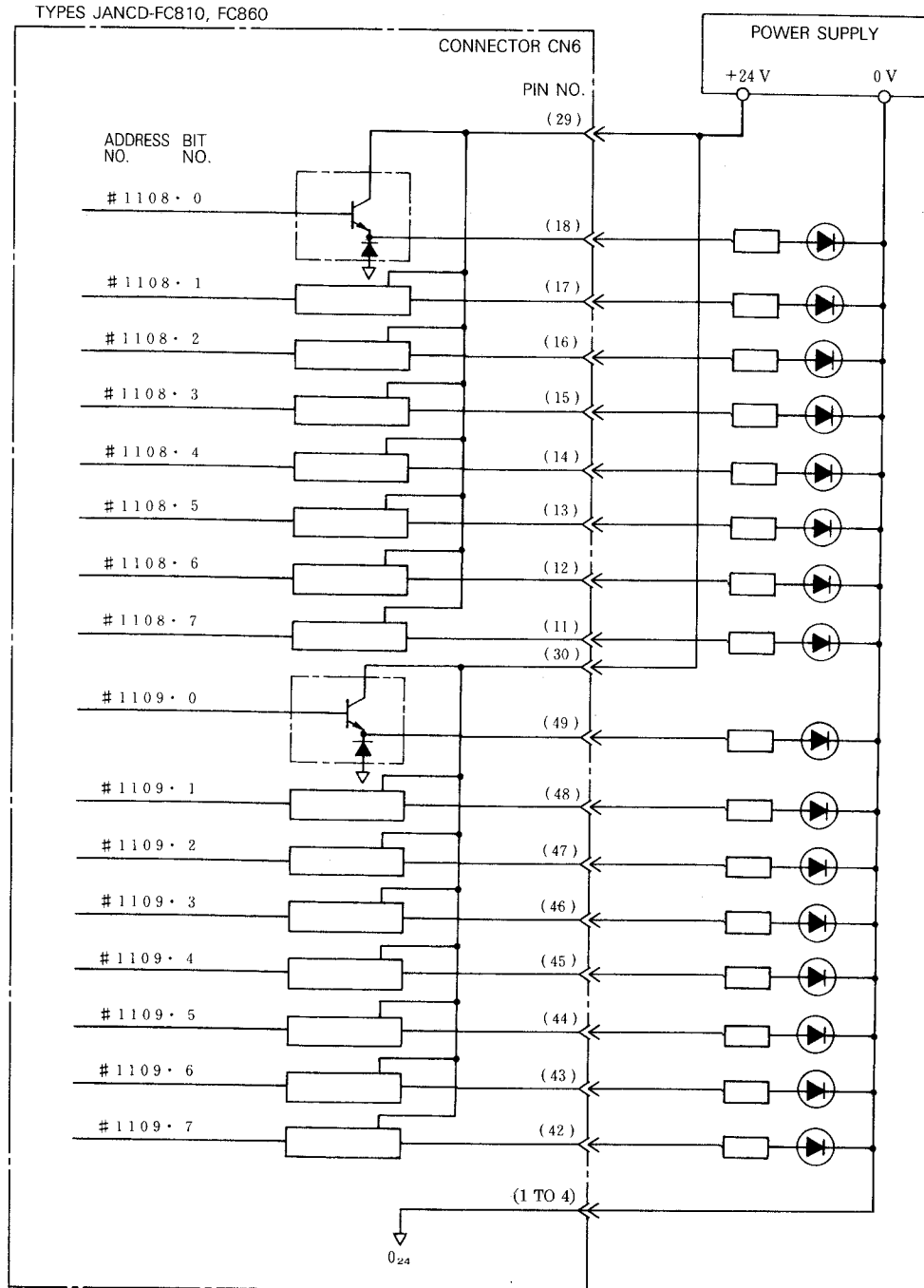

Note :

The addresses are those for module No.1. (#1108.0 to #1109.7). The address layouts for modules Nos. 2 and 3 are the same as shown above starting with newer addresses. Refer to Appendix B (3), Address Classification for details.

Fig. 17.16 Connection to Address and Bit Nos.
#1108.0 to #1109.7 on FC810/FC860 Modules

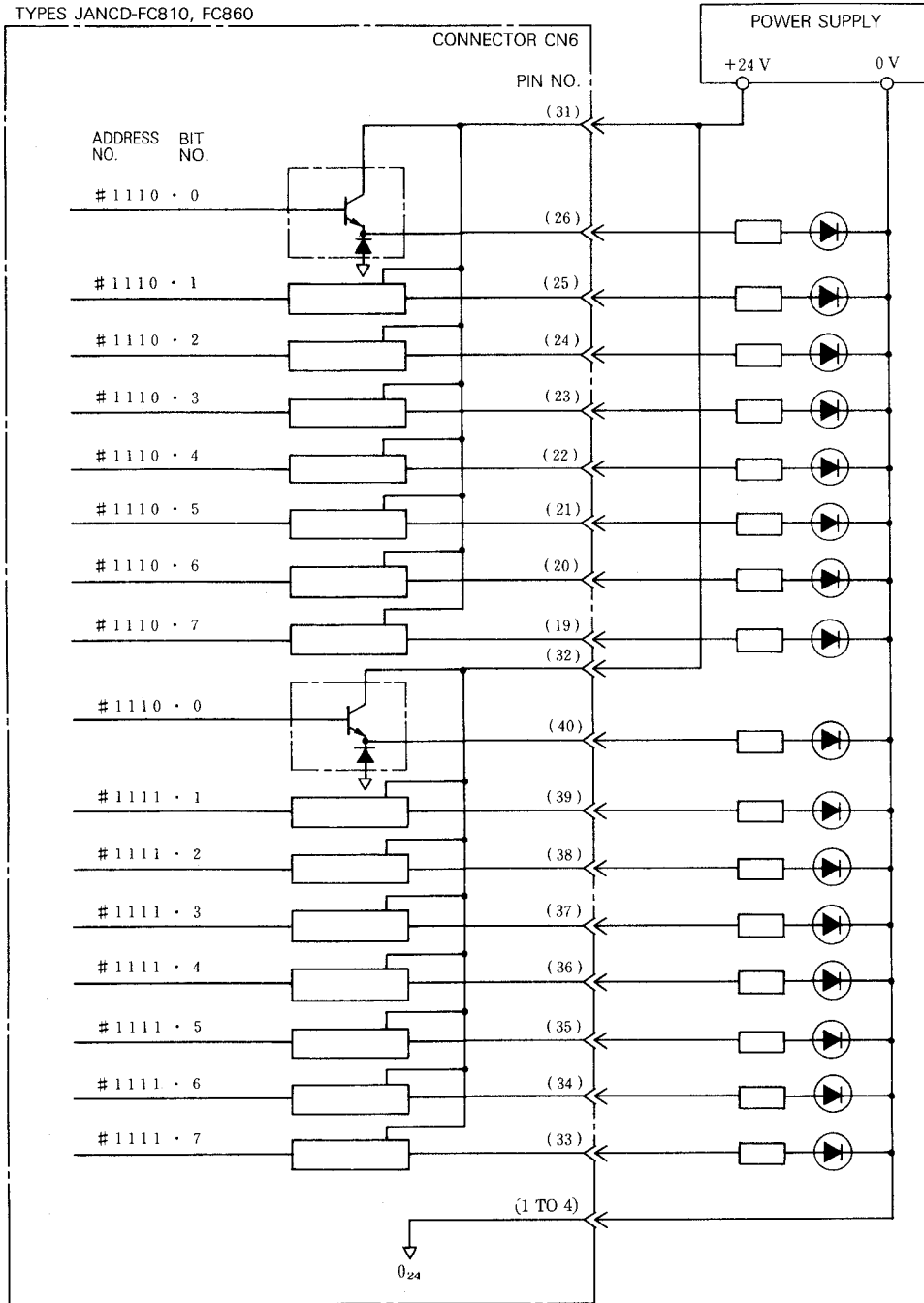

Note :

The addresses are those for module No.1. (#1110.0 to #1111.7). The address layouts for modules Nos. 2 and 3 are the same as shown above starting with newer addresses. Refer to Appendix B (3), Address Classification for details.

Fig. 17.17 Connection to Address and Bit Nos. #1110.0 to #1111.7 on FC810/FC860 Modules

17.2.2 FC 861 MODULE

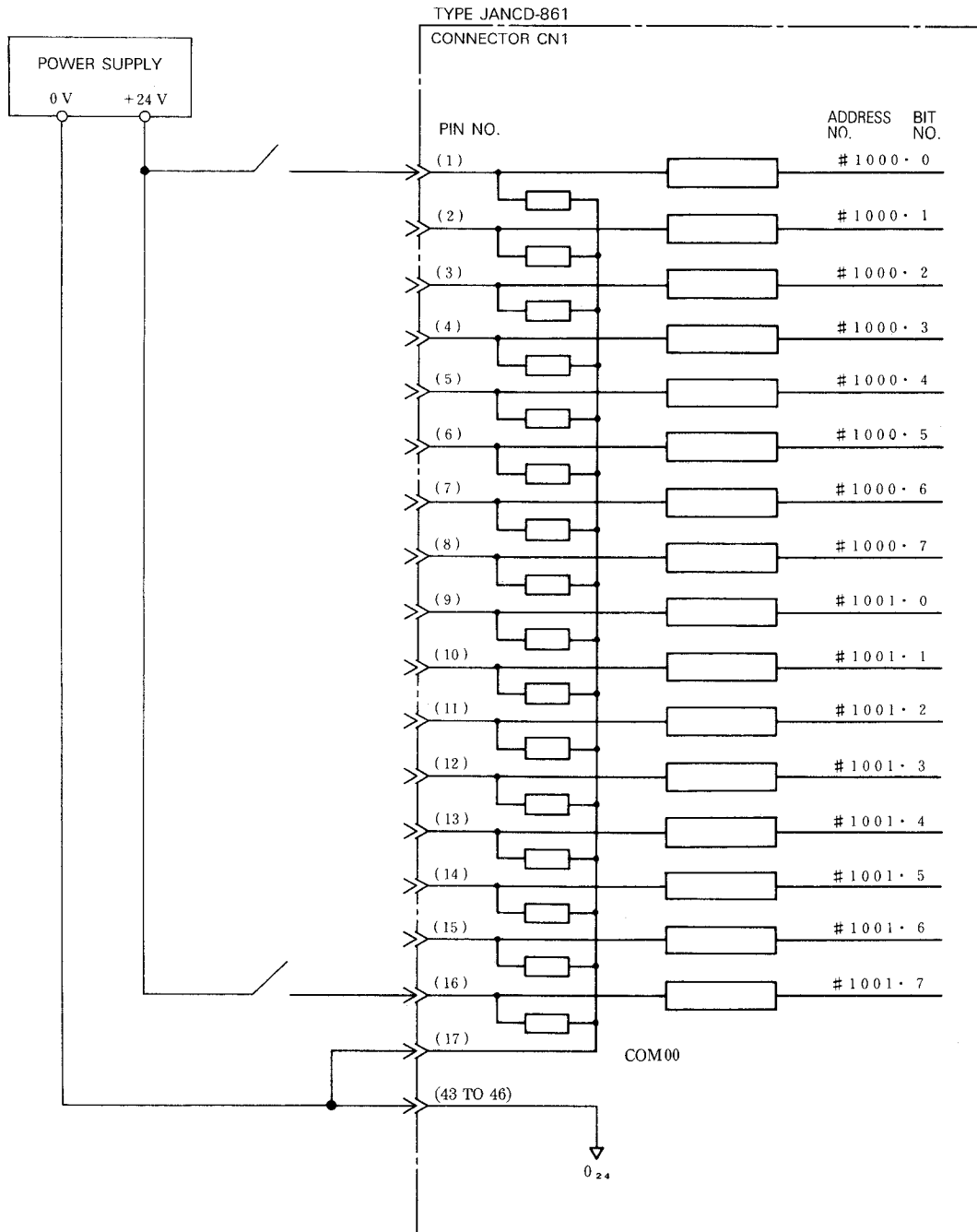

Notes :

1. This connection example shows +24 V common.
0 V common is also available. Refer to Par. 18.3.2.2, I/O Module Types JANCD-FC861 for connection details.
2. The addresses are those for module No.1. (#1000.0 to #1001.7). The address layouts for modules Nos. 2 to 7 are the same as shown above starting with newer addresses. Refer to Appendix B (3), Address Classification for details.

Fig. 17.18 Connection to Address and Bit Nos. #1000.0 to #1001.7 on FC861 Module

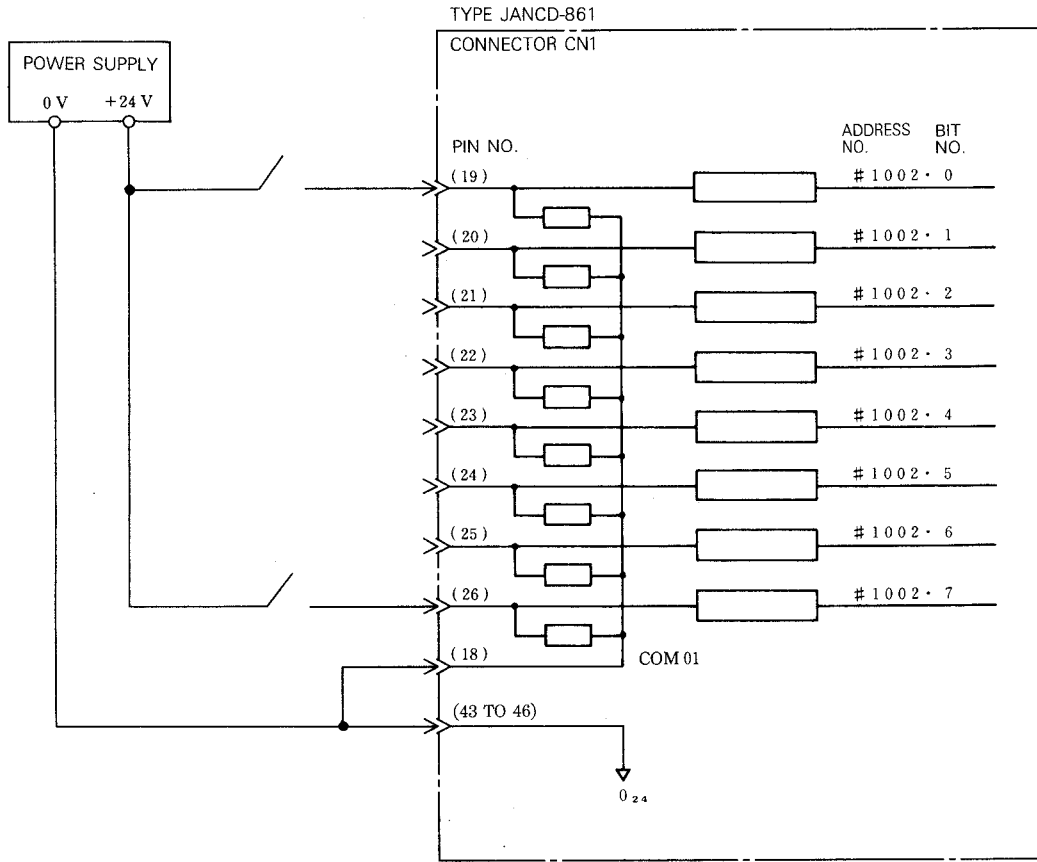

Notes :

1. This connection example shows +24 V common.
0 V common is also available. Refer to par. 18.3.2.2 I/O Module Types JANCD-FC861 for connection details.
2. The addresses are those for module No.1. (#1002.0 to #1002.7). The address layouts for modules Nos. 2 to 7 are the same as shown above starting with newer addresses. Refer to Appendix B (3), Address Classification for details.

Fig. 17.19 Connection to Address and Bit Nos.
#1002.0 to #1002.7 on FC861 Module

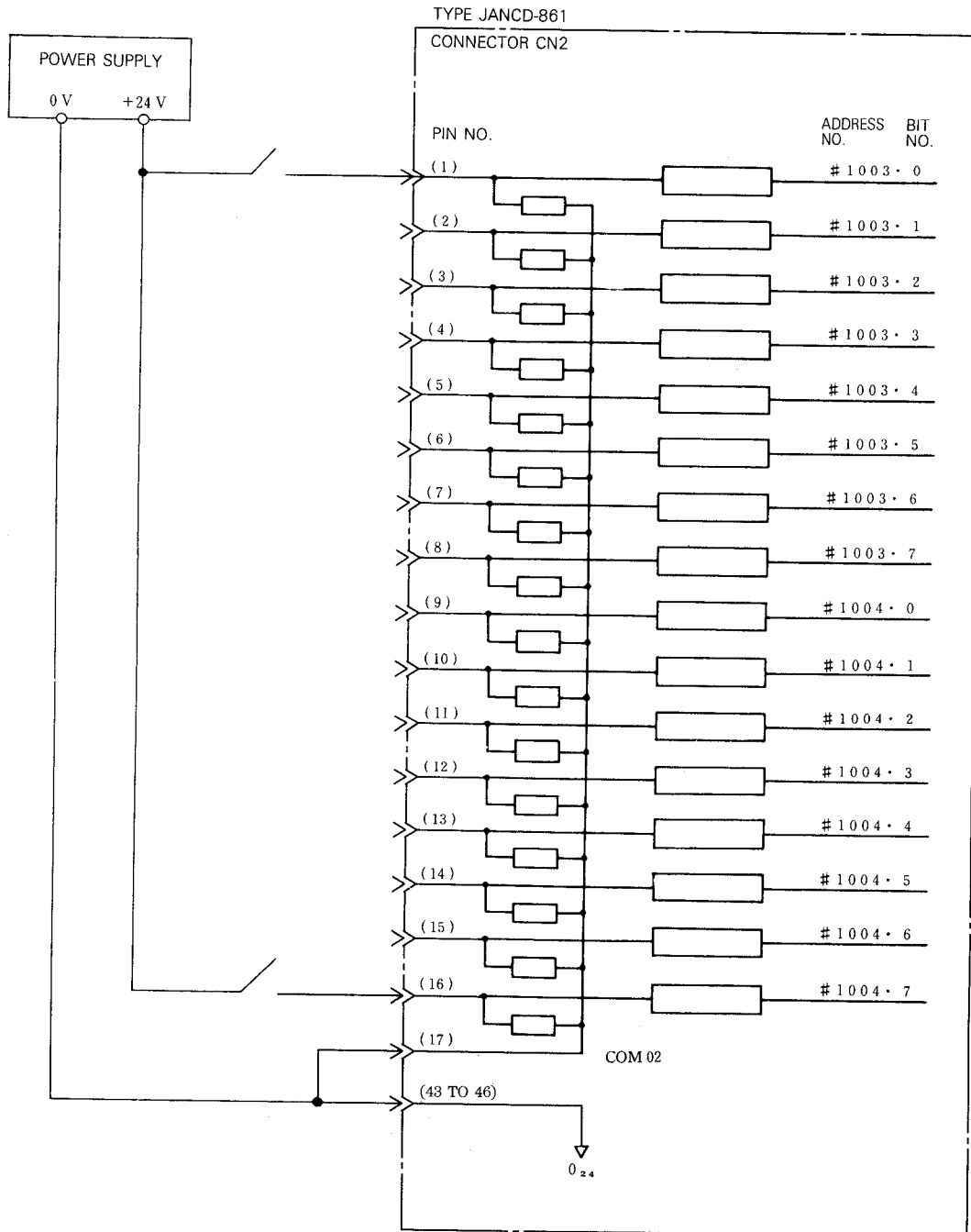

Notes :

1. This connection example shows +24 V common.
0 V common is also available. Refer to Par. 18.3.2.2, I/O Module Types JANCD-FC861 for connection details.
2. The addresses are those for module No.1. (#1003.0 to #1104.7). The address layouts for modules Nos. 2 to 7 are the same as shown above starting with newer addresses. Refer to Appendix B (3), Address Classification for details.

Fig. 17.20 Connection to Address and Bit Nos.
#1003.0 to #1104.7 on FC861 Module

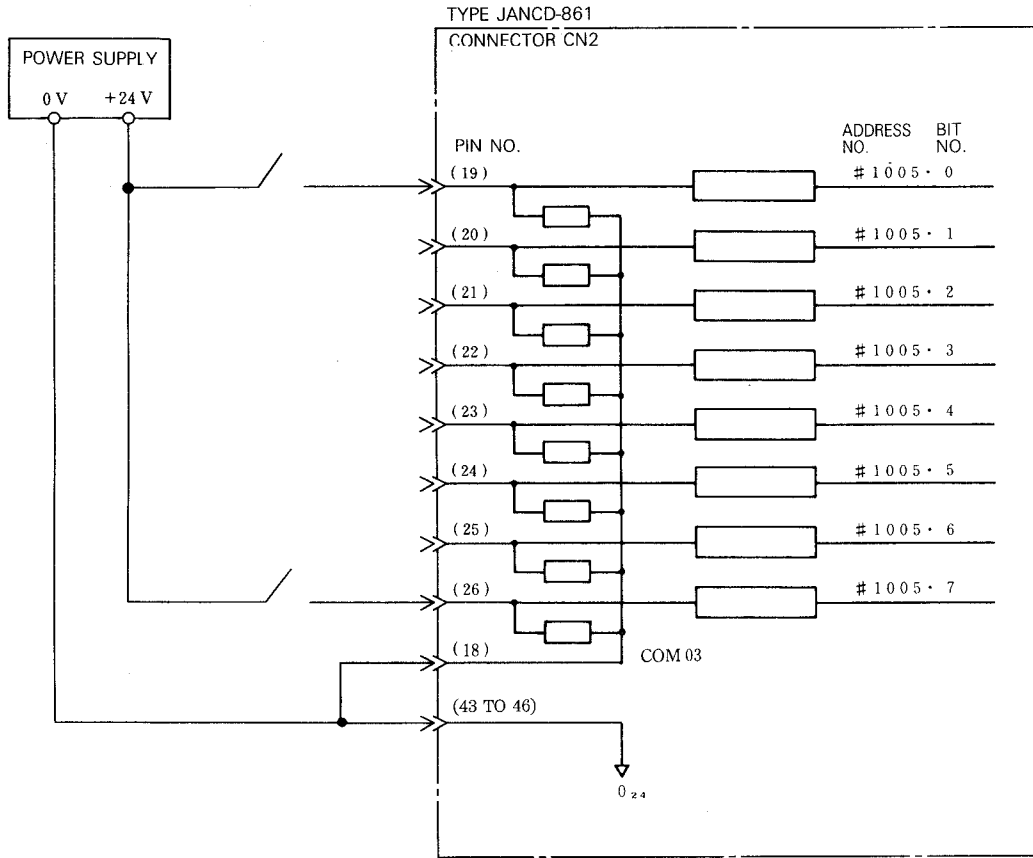

Notes :

1. This connection example shows +24 V common.
0 V common is also available. Refer to Par. 18.3.2.2, I/O Module Types JANCD-FC861 for connection details.
2. The addresses are those for module No.1. (#1005.0 to #1105.7). The address layouts for modules Nos. 2 to 7 are the same as shown above starting with newer addresses. Refer to Appendix B (3), Address Classification for details.

Fig. 17.21 Connection to Address and Bit Nos.
#1005.0 to #1005.7 on FC861 Module

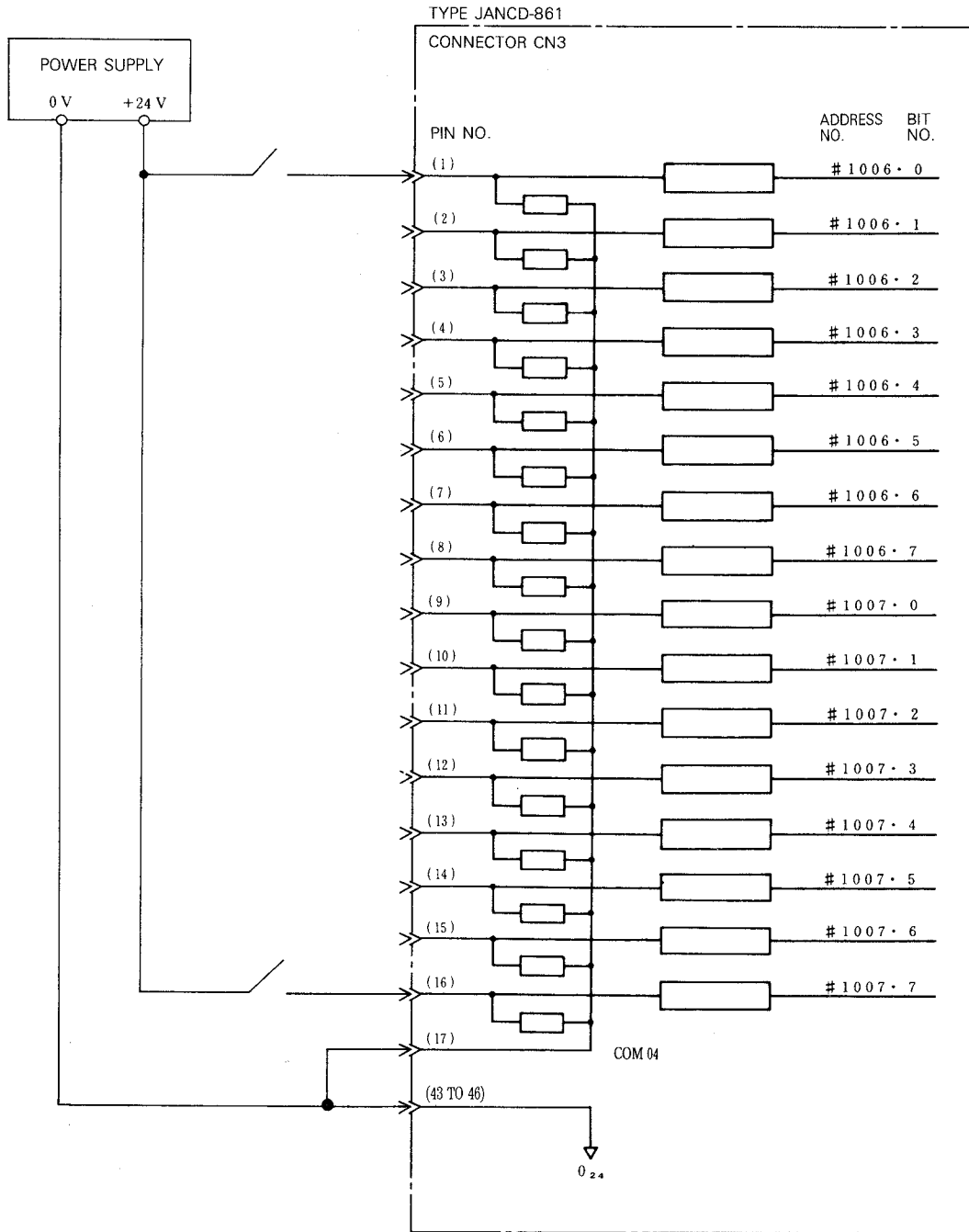

Notes :

1. This connection example shows +24 V common.
0 V common is also available. Refer to Par. 18.3.2.2, I/O Module Types JANCD-FC861 for connection details.
2. The addresses are those for module No.1. (#1006.0 to #1007.7). The address layouts for modules Nos. 2 to 7 are the same as shown above starting with newer addresses. Refer to Appendix B (3), Address Classification for details.

Fig. 17.22 Connection to Address and Bit Nos.
#1006.0 to #1007.7 on FC861 Module

TYPE JANCD-861

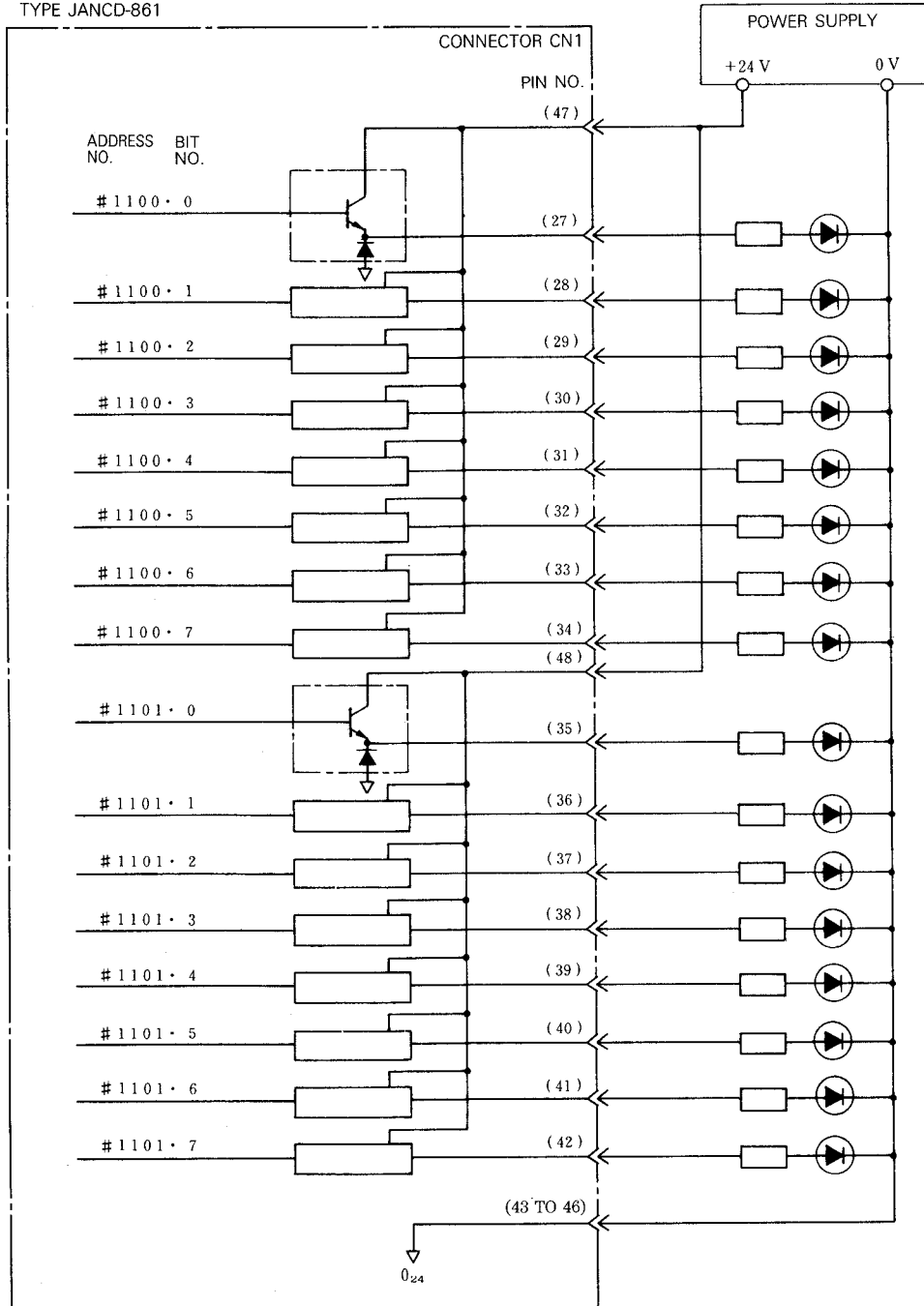

Note :

The addresses are those for module No.1-1. (#1100.0 to #1101.7). The address layouts for modules Nos. 2 to 7 are the same as shown above starting with newer addresses. Refer to Appendix B (3), Address Classification for details.

Fig. 17.23 Connection to Address and Bit Nos. #1100.0 to #1101.7 on FC861 Module

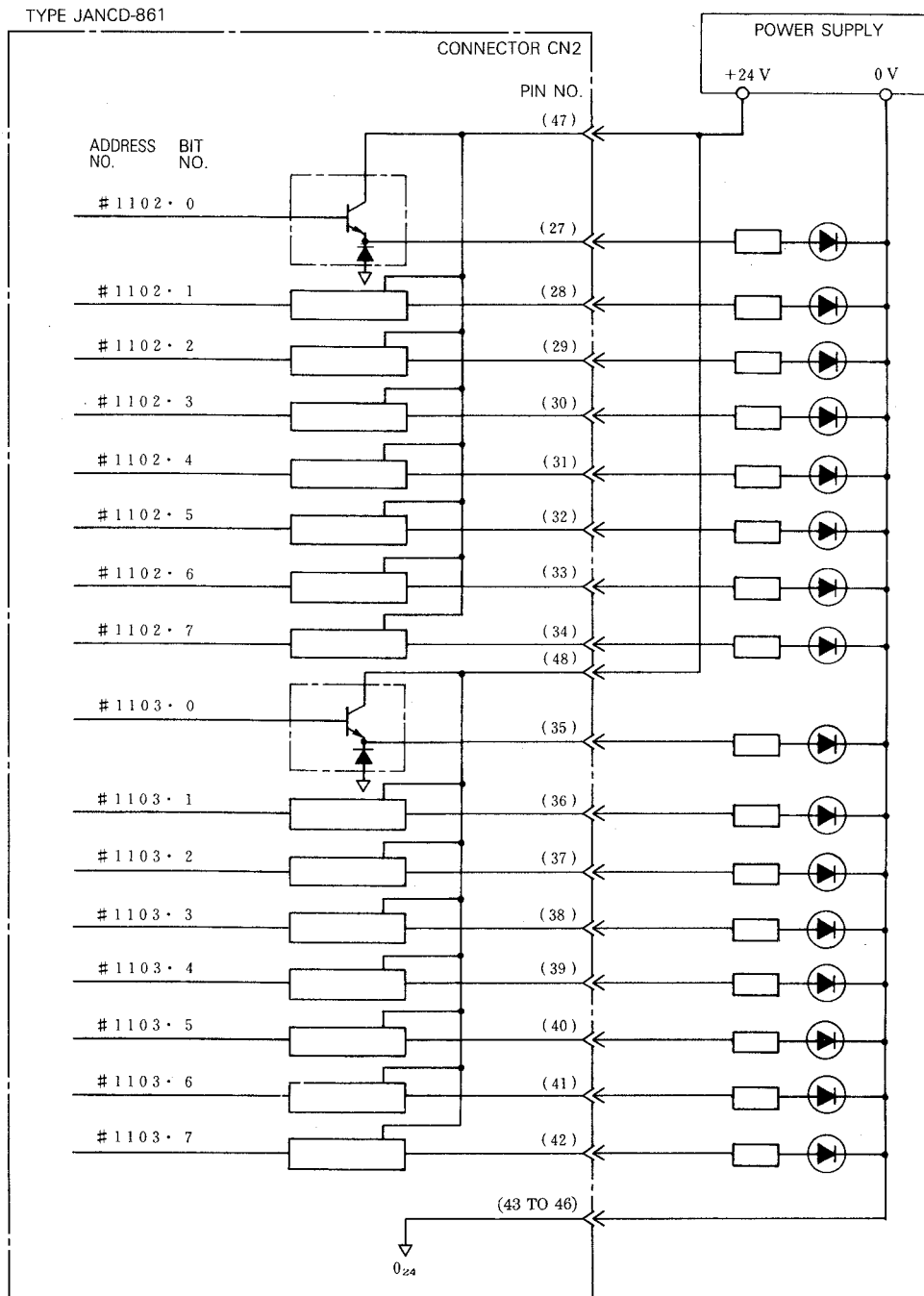

Note :

The addresses are those for module No.1-1. (#1102.0 to #1103.7). The address layouts for modules Nos. 2 to 7 are the same as shown above starting with newer addresses. Refer to Appendix B (3), Address Classification for details.

Fig. 17.24 Connection to Address and Bit Nos.
#1102.0 to #1103.7 on FC861 Module

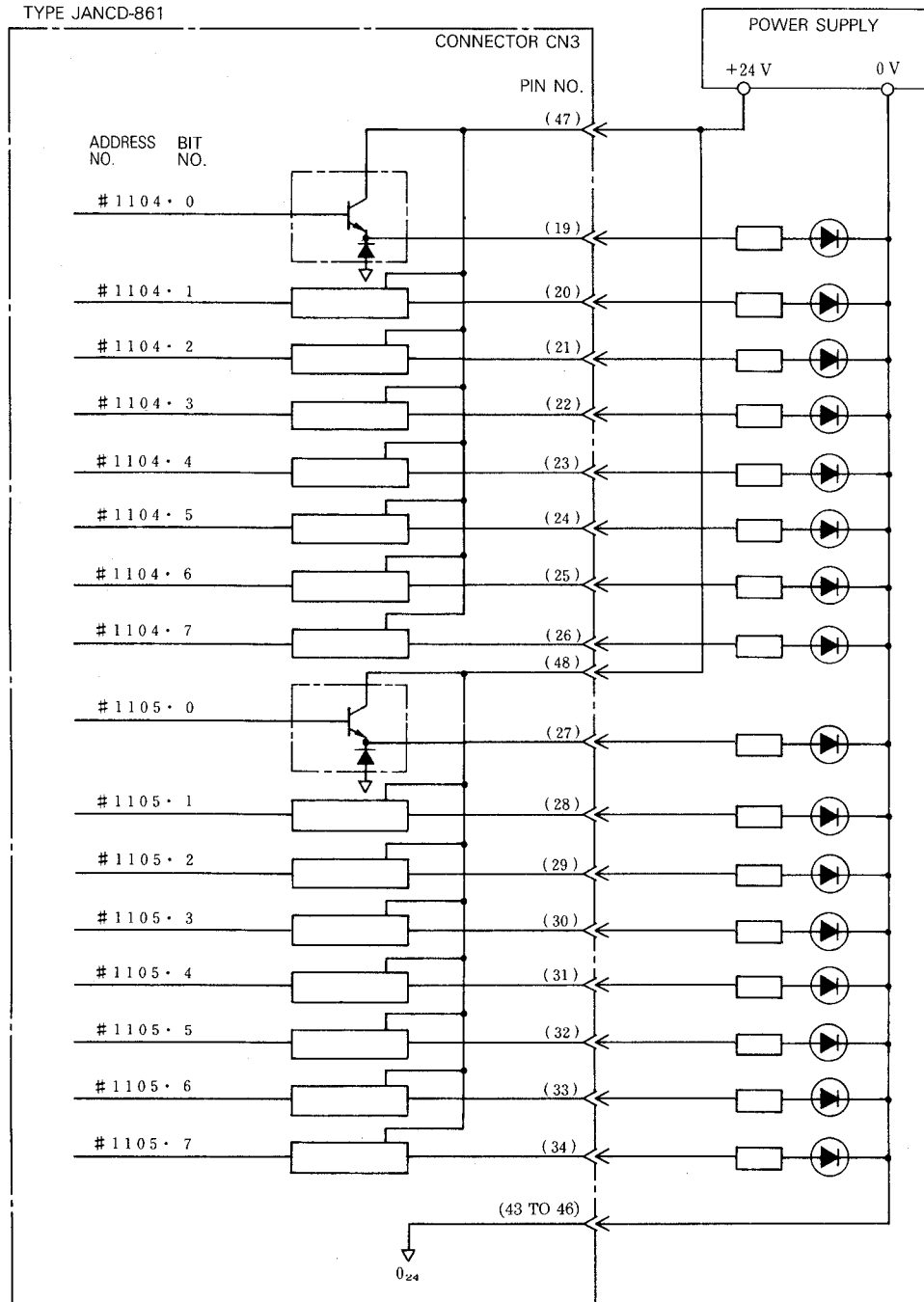

Note :

The addresses are those for module No.1-1. (#1104.0 to #1105.7). The address layouts for modules Nos. 2 to 7 are the same as shown above starting with newer addresses. Refer to Appendix B (3), Address Classification for details.

Fig. 17.25 Connection to Address and Bit Nos
#1104.0 to #1105.7 on FC861 Module

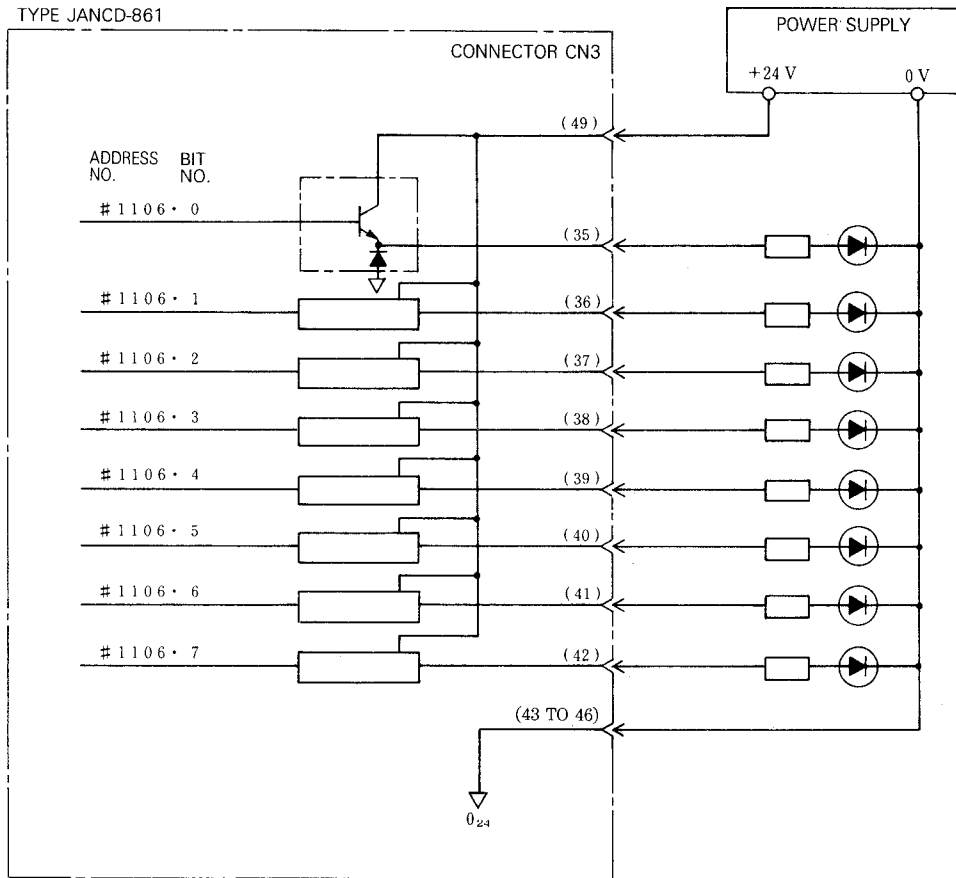

Note :

The addresses are those for module No.1-1. (#1106.0 to #1106.7). The address layouts for modules Nos. 2 to 7 are the same as shown above starting with newer addresses. Refer to Appendix B (3), Address Classification for details.

Fig. 17.26 Connection to Address and Bit Nos. #1106.0 to #1106.7 on FC861 Module

17.2.3 SP 50 BOARD

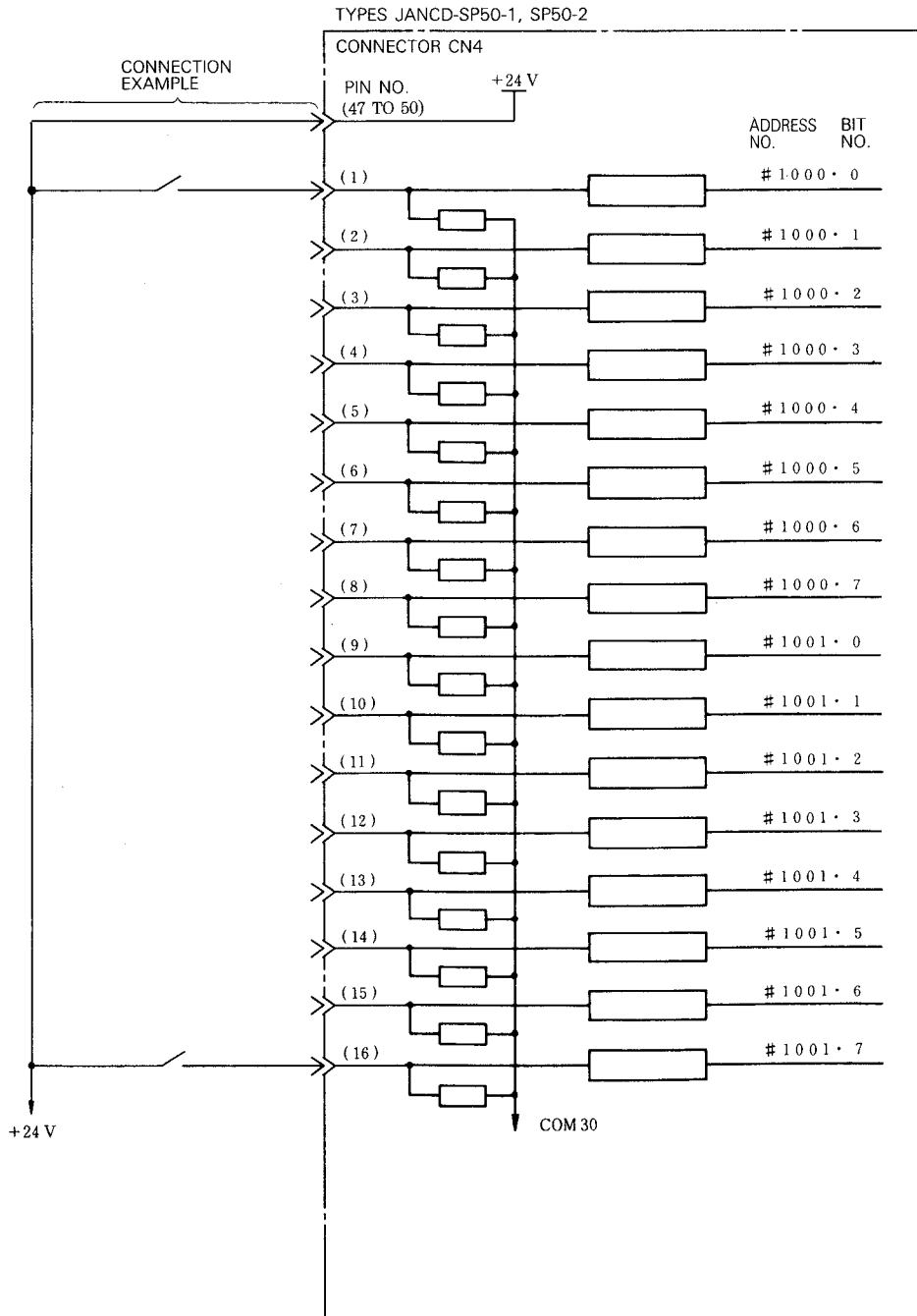

Notes :

1. This connection example shows +24 V common.
0 V common is also available. Refer to Par. 18.3.2.3, SP50 Board for connection details.
2. The addresses are those for module No.1-1. (#1000.0 to #1001.7). The address layouts for modules Nos. 2 to 8 are the same as shown above starting with newer addresses. Refer to Appendix B (3), Address Classification for details.

Fig. 17.27 Connection to Address and Bit Nos.
#1000.0 to #1001.7 on SP50 Board

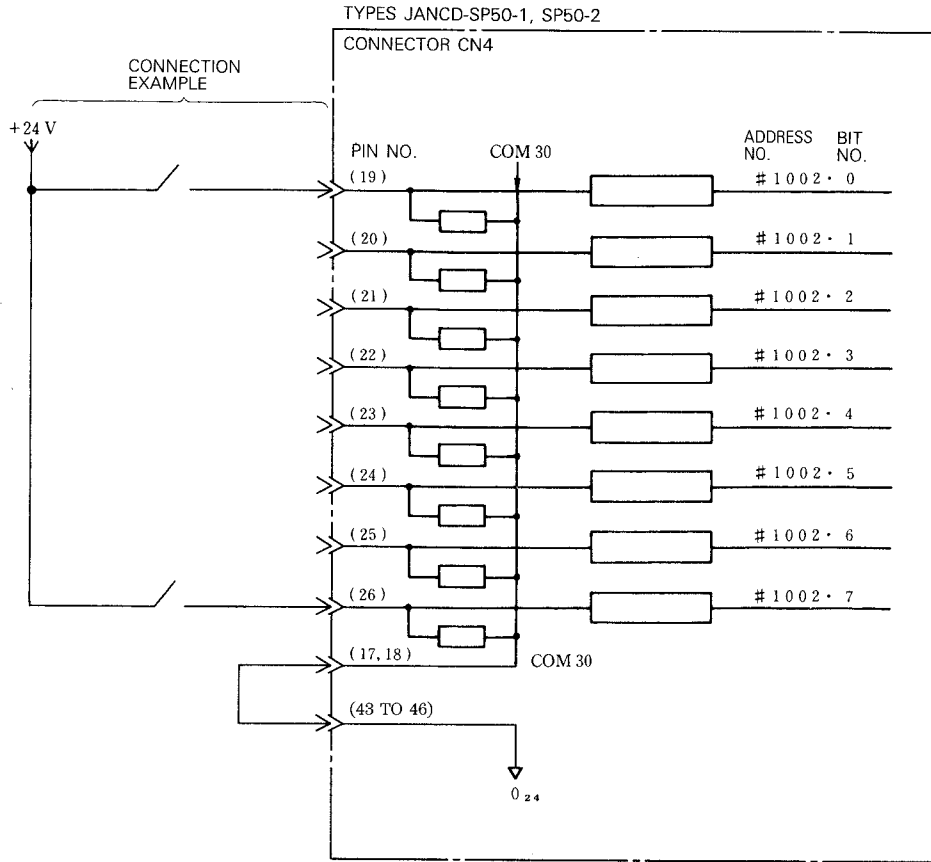

Notes :

1. This connection example shows +24 V common.
0 V common is also available. Refer to Par. 18.3.2.3, SP50 Board for connection details.
2. The addresses are those for module No.1-1. (#1002.0 to #1002.7). The address layouts for modules Nos. 2 to 8 are the same as shown above starting with newer addresses. Refer to Appendix B (3), Address Classification for details.

Fig. 17.28 Connection to Address and Bit Nos.
#1002.0 to #1002.7 on SP50 Board

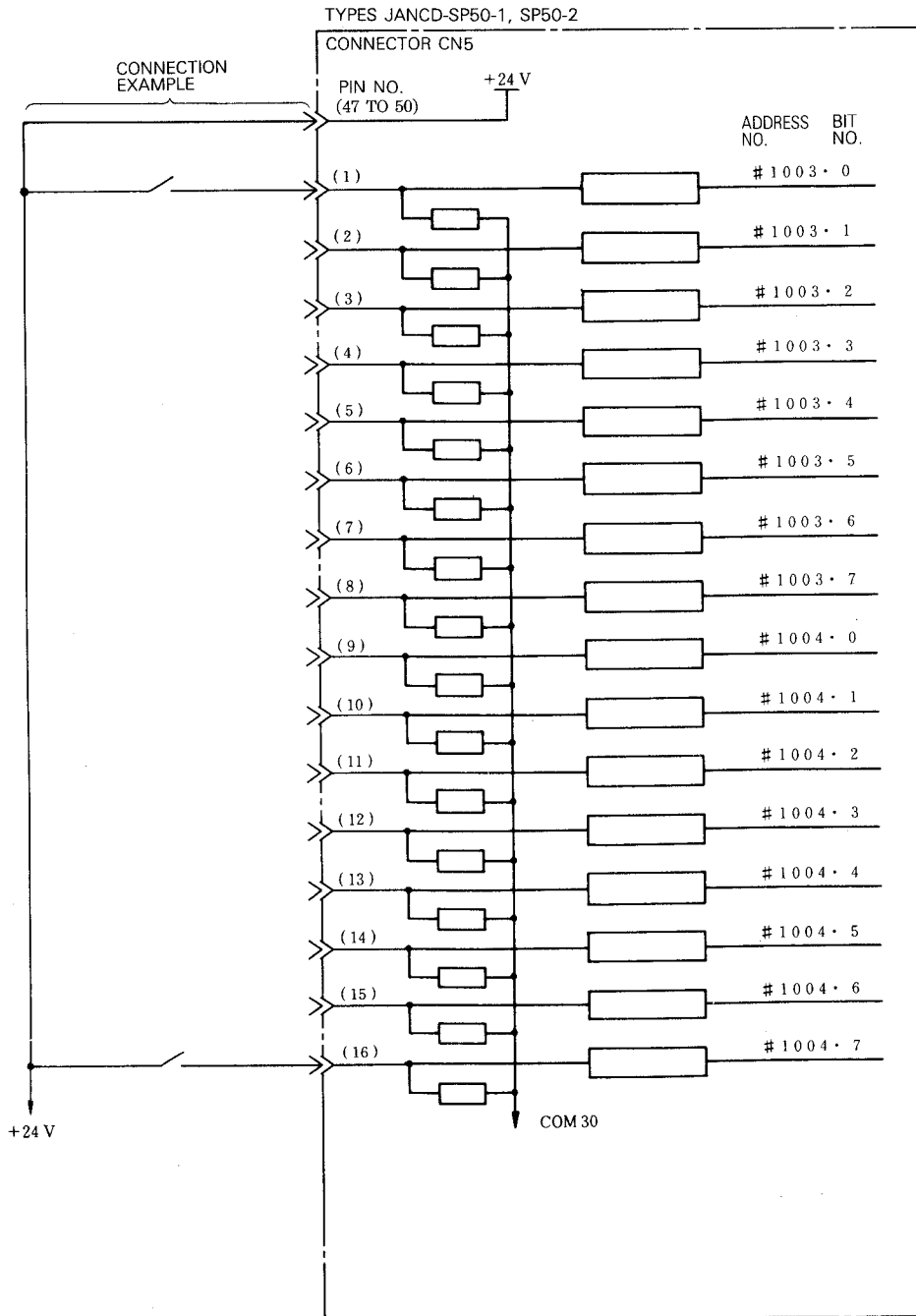

Notes :

1. This connection example shows +24 V common.
0 V common is also available. Refer to Par. 18.3.2.3, SP50 Board for connection details.
2. The addresses are those for module No.1-1. (#1003.0 to #1004.7). The address layouts for modules Nos. 2 to 8 are the same as shown above starting with newer addresses. Refer to Appendix B (3), Address Classification for details.

Fig. 17.29 Connection to Address and Bit Nos.
#1003.0 to #1004.7 on SP50 Board

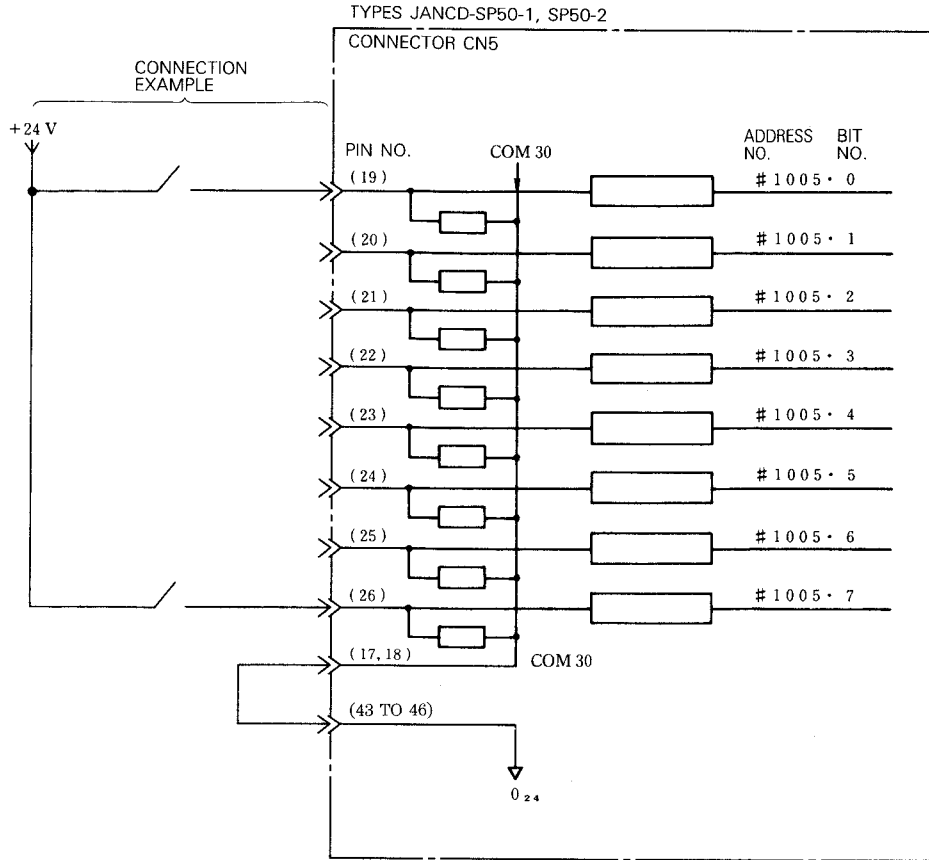

Notes :

1. This connection example shows +24 V common.
0 V common is also available. Refer to Par. 18.3.2.3, SP50 Board for connection details.
2. The addresses are those for module No.1-1. (#1005.0 to #1005.7). The address layouts for modules Nos. 2 to 8 are the same as shown above starting with newer addresses. Refer to Appendix B (3), Address Classification for details.

Fig. 17.30 Connection to Address and Bit Nos.
#1005.0 to #1005.7 on SP50 Board

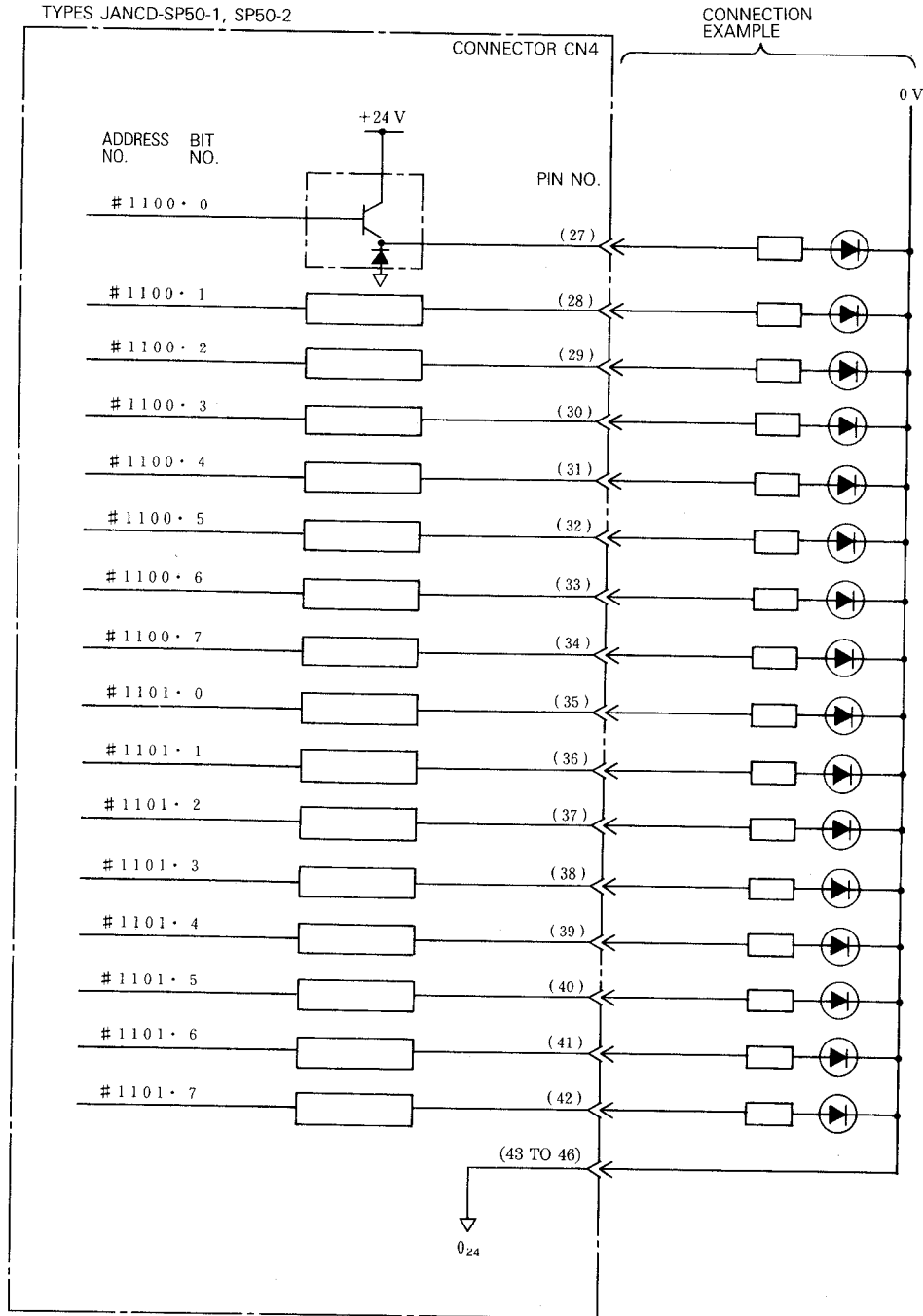

Notes :

1. This connection example shows +24 V common.
0 V common is also available. Refer to par. 18.3.2.3 SP50 Board for connection details.
2. The addresses are those for module No.1-1. (#1100.0 to #1101.7). The address layouts for modules Nos. 2 to 8 are the same as shown above starting with newer addresses. Refer to Appendix B (3), Address Classification for details.

Fig. 17.32 Connection to Address and Bit Nos.
#1100.0 to #1101.7 on SP50 Board

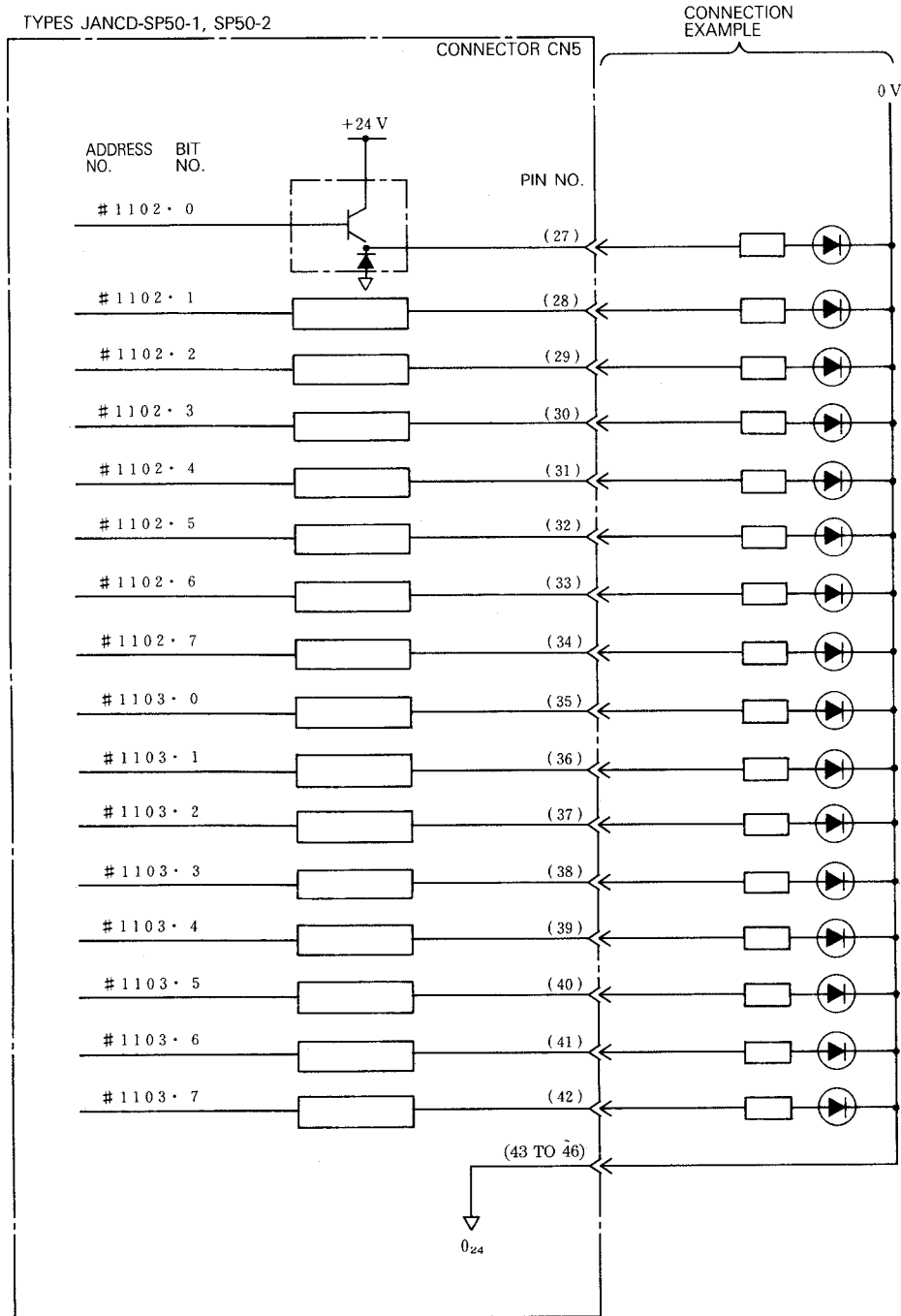

Notes :

1. This connection example shows +24 V common.
0 V common is also available. Refer to Par. 18.3.2.3, SP50 Board for connection details.
2. The addresses are those for module No.1-1. (#1102.0 to #1103.7). The address layouts for modules Nos. 2 to 8 are the same as shown above starting with newer addresses. Refer to Appendix B (3), Address Classification for details.

Fig. 17.33 Connection to Address and Bit Nos.
#1102.0 to #1103.7 on SP50 Board

TYPES JANCD-SP50-2

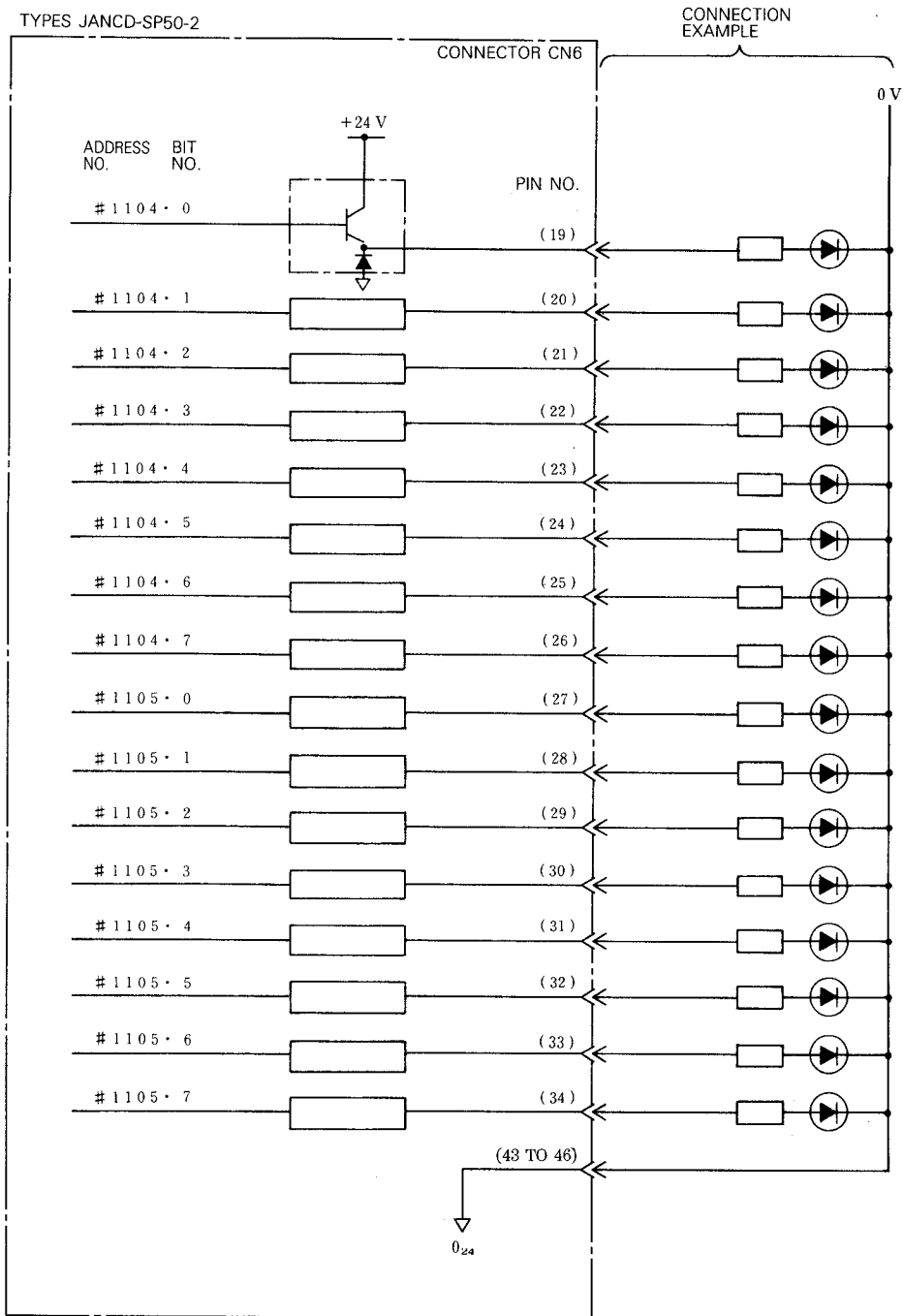

Notes :

1. This connection example shows +24 V common.
0 V common is also available. Refer to Par. 18.3.2.3, SP50 Board for connection details.
2. The addresses are those for module No.1-1. (#1104.0 to #1105.7). The address layouts for modules Nos. 2 to 8 are the same as shown above starting with newer addresses. Refer to Appendix B (3), Address Classification for details.

Fig. 17.34 Connection to Address and Bit Nos.
#1104.0 to #1105.7 on SP50 Board

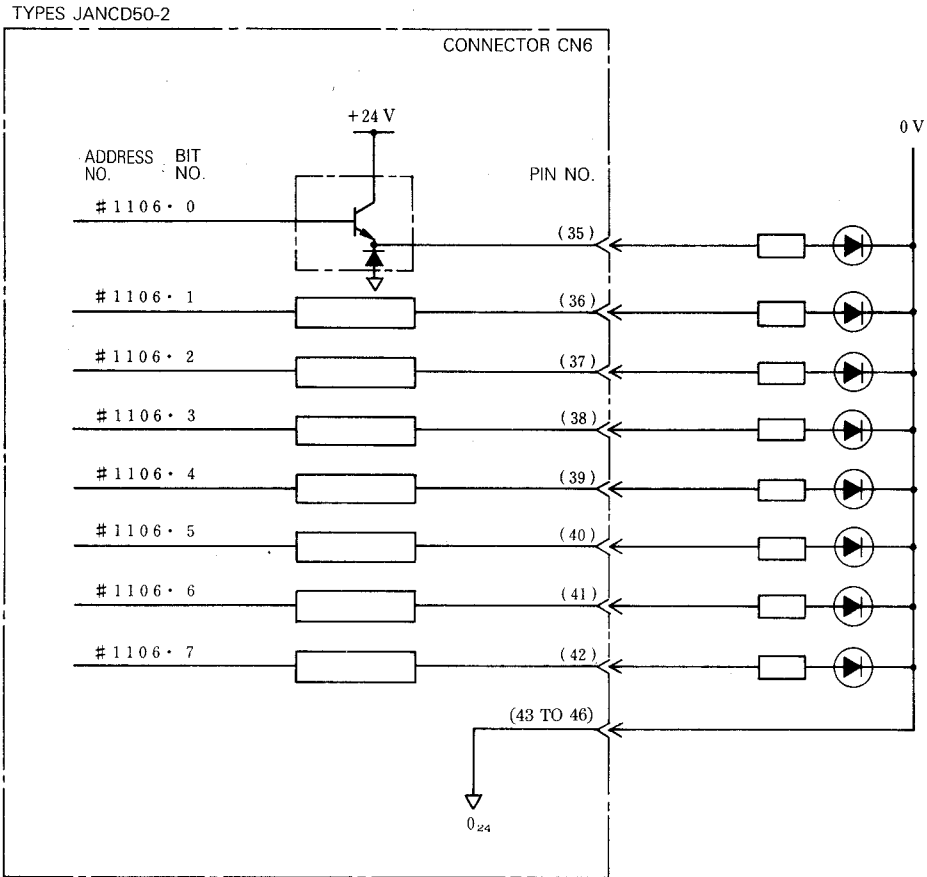

Notes :

1. This connection example shows +24 V common.
0 V common is also available. Refer to Par. 18.3.2.3, SP50 Board for connection details.
2. The addresses are those for module No.1-1. (#1106.0 to #1106.7). The address layouts for modules Nos. 2 to 8 are the same as shown above starting with newer addresses. Refer to Appendix B (3), Address Classification for details.

Fig. 17.35 Connection to Address and Bit Nos.
#1106.0 to #1106.7 on SP50 Board

17.3 EXPLANATION OF GENERAL-PURPOSE I/O SIGNALS

17.3.1 I/O PORTS

(1) The YASNAC J50 contains the programmable controller system (PC). External signals can be allocated to its I/O ports freely when the machine manufacturer designs a built-in PC. For details, refer to Instruction Manual for YASNAC J50 PC System (SIE-C843-12.1).

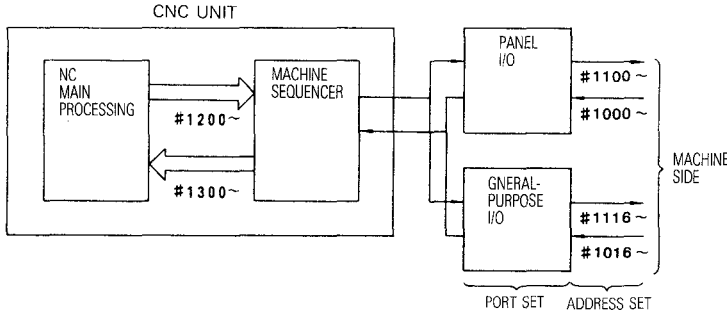

Fig. 17.36 System Configuration

(2) The general-purpose I/O ports are mounted on the I/O module types JANCD-FC810, FC860, FC861 and on the SP50 board of the CNC operator's panel.

The numbers of I/O points of these modules are shown in Table 17.1.

Table 17.1 Numbers of I/O Points of Modules

Module Type	Input Points	Output Points	Remarks
JANCD-FC810/FC860	112	96	For machine panels
FC861	64	56	
SP50-1	64	32	
SP50-2	64	56	

Notes :

1. YASNAC J50 needs one I/O board incorporated in a CNC operator's panel (SP50-1 or SP50-2). Therefore, up to 3 board (max. inputs: 512 points, max. outputs: 344 points) can be connected when only FC 810/FC860 is added. Up to 7 boards (max. inputs: 512 points, max. outputs: 448 points) can be connected.
2. Each module can be used together with the other. However, an I/O area number must not be overlapped. (Refer to Appendix 2.) If any I/O area number is overlapped, alarm No. 374 occurs or status changes to the input disabled status.
3. In order to make it possible to add more modules, it is necessary for each I/O module to terminate the final board.

(3) Address Setting

The relationship between the address and connectors is indicated in Table 18.1. (This table applies to port 1. If a different port is used, address changes are required.)

Table 17.2 Address and Connector

Address		Panel I/O	General-purpose I/O	General-purpose I/O
Input	Output	(JANCD-SP50-1, SP50-2)	(JANCD-FC810, FC860)	(JANCD-FC861)
#1000		CN4	CN4 COM30	CN1 COM00
#1001		CN4	CN4 COM30	CN1 COM01
#1002		CN4	CN4 COM31	CN2 COM02
#1003		CN5	CN4 COM32	CN2 COM03
#1004		CN5	CN5 COM40	CN3 COM04
#1005		CN5	CN5 COM41	
#1006		CN6	CN5 COM42	
#1007		CN6	CN3 COM20	
#1008		—	CN3 COM21	
#1009		—	CN3 COM21	
#1010		—	CN2 COM10	
#1011		—		
#1012		—		
#1013		—		
#1100		CN4	CN1	CN1
#1101		CN4	CN1	CN1
#1102		CN5	CN1	CN2
#1103		CN5	CN1	CN2
#1104		[CN6]	CN1	CN3
#1105		[CN6]	CN2	CN3
#1106		[CN6]	CN3	CN3
#1107		—	CN3	
#1108		—	CN6	
#1109		—	CN6	
#1110		—	CN6	
#1111		—	CN6	
Sum		IN64/OUT32 (OUT56)	IN112/OUT96	IN64/OUT56

17.3.2 I/O CIRCUITS OF I/O PORTS

17.3.2.1 I/O MODULE TYPE JANCD-FC810/FC860

(1) Input Circuits

0 V common and 24 V common can be set by an external device for the input circuit.

Internal power supply and external power supply can be used for 24 V power supply.

(a) When the internal power supply is used.

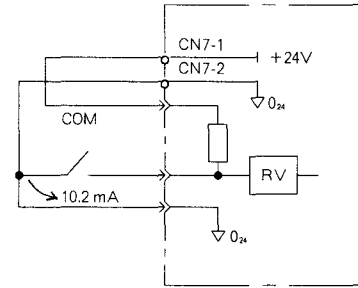

0 V Common

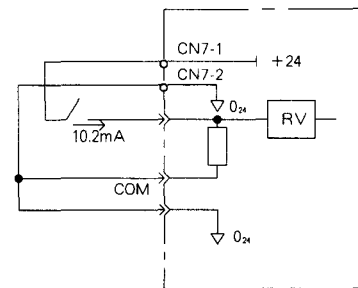

+24 V Common

Fig. 17.37 Internal Input Circuits

(b) When the external power supply is used.

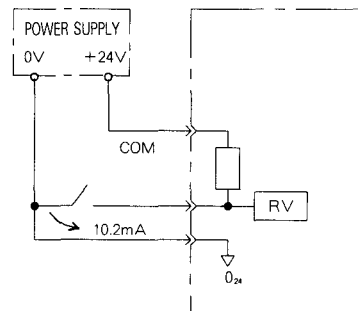

0 V Common

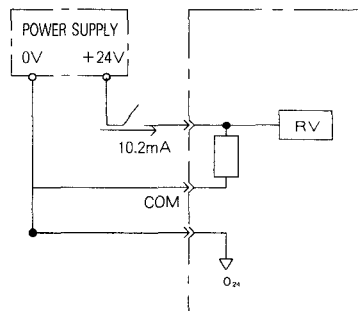

+24 V Common

Fig. 17.38 External Input Circuits

Note :

"Common" in the input circuit (for example, COM10, COM20, COM21...total 9) can be either "+24 V common" or "0 V common" for every 8 or 16 input points as mentioned in Par. 17.3 I/O signal interface and can be selected freely. Set by wiring on the cable side.

17.3.2.1 I/O MODULE TYPE JANCD-FC810/FC860 (Cont'd)

(2) Output Circuits

An noncontact wity polarity is used for outputs. Current under operation must be 60 mA max (per circuit).

Internal power supply and external power supply can be used for 24 V power supply.

(a) When the internal power supply is used.

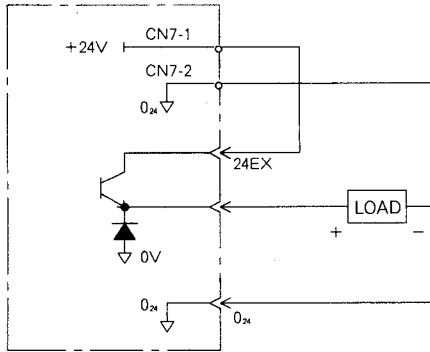

Fig. 17.39 Internal Output Circuit

(b) When the external power supply is used.

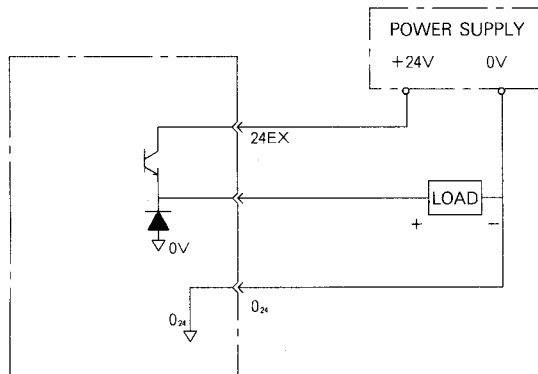

Fig. 17.40 External Output Circuit

Notes :

1. All 96 output points are transistor source driver outputs. The current when ON should be maximum 60 mA per circuit.
2. Every 8 points out of 96 outputs can be connected to some external power supplies.
3. When driving to LEDs with internal power supply, the current of all the I/O circuits should be 3.5 A max.

17.3.2.2 I/O MODULE TYPE JANCD-FC861

(1) Input Circuits

0 V common and +24 V common can be set by an external device for the input circuit.

Internal power supply and external power supply can be used for 24 V power supply. When internal power supply is used, mount power supply selection connector on CNINT. When external power supply is used, mount power supply selection connector on CNINT.

(a) When the Internal power supply is used.

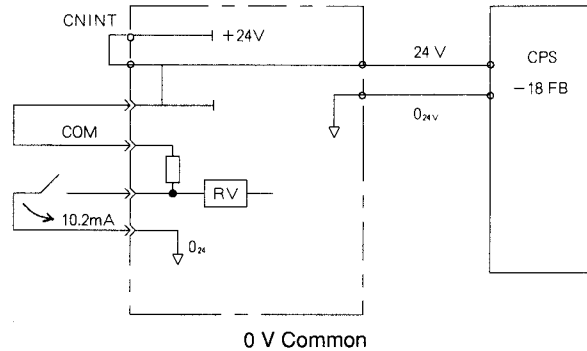

0 V Common

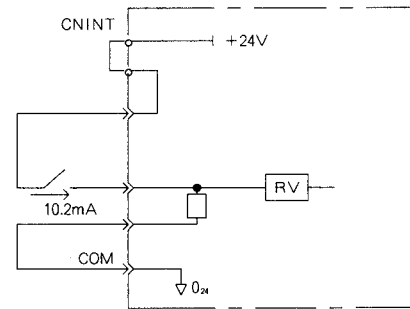

+24 V Common

Fig. 17.41 Internal Input Circuits

(b) When the external power supply is used.

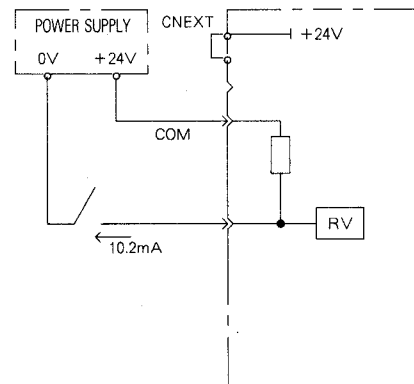

0 V Common

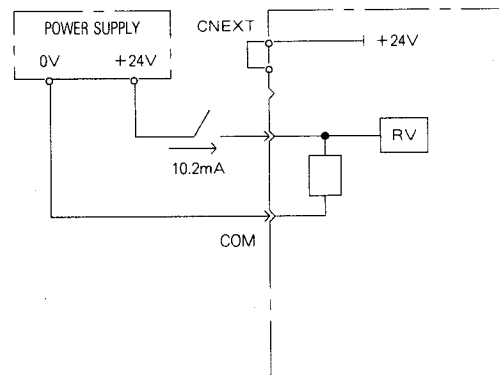

+24 V Common

Fig. 17.42 External Input Circuits

Note :

"Common" in the input circuit (for example, COM10, COM20, COM21...total 9) can be either "+24 V common" or "0 V common" for every 8 or 16 input points as mentioned in Par. 17.3 I/O signal interface and can be selected freely. Set by wiring on the cable side.

(2) Output Circuits

A noncontact with polarity is used for outputs. Current under operation must be at most 60 mA (per circuit).

Internal power supply and external power supply can be used for 24 V power supply.

(a) When the internal power supply is used.

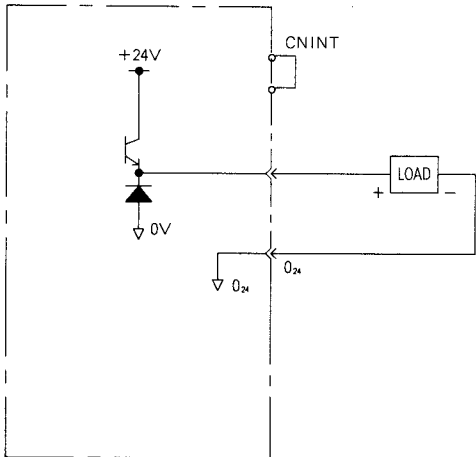

Fig. 17.43 Internal Output Circuit

(b) When the external power supply is used.

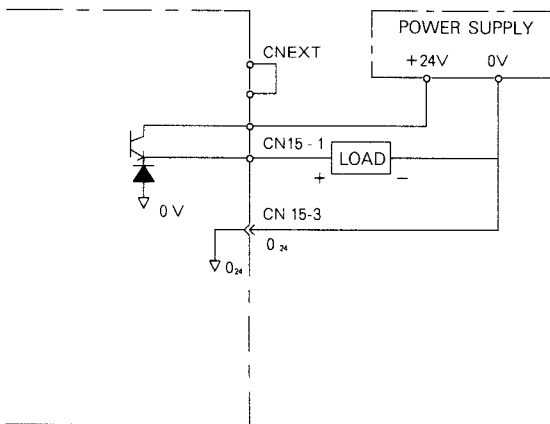

Fig. 17.44 External Output Circuit

Notes :

1. All 56 output points are polarized contactless (transistorized source driver) outputs. The current when ON should be maximum 60 mA per circuit.
2. When driving the LEDs with internal power supply, the current of all the I/O circuits should be max. 3.5 A.

17.3.2.3 SP50 BOARD (TYPE JANCD-SP50)

(1) Input Circuits

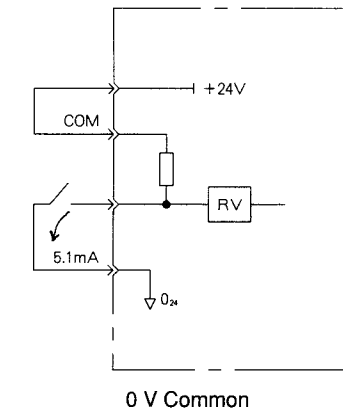

0 V Common

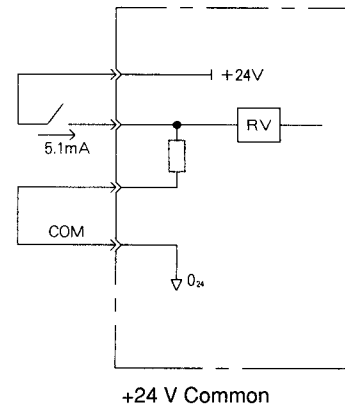

+24 V Common

Fig. 17.45 Input Circuits

(2) Output Circuits (with Internal Power Supply)

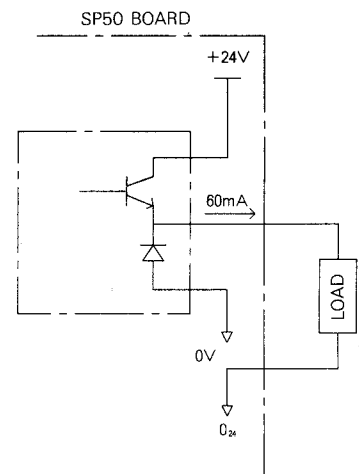

Fig. 17.46 Output Circuit

Note :

A noncontact with polarity is used for 56 outputs. Current under operation must be at most 60 mA (per circuit).

17.3.3 POWER SUPPLY FOR I/O SIGNALS

(1) Internal power Supply

Internal power supply +24 V for I/O signals should be provided by the machine tool builder. If internal power supply is used, calculate the load current according to I/O points and confirm that the current is within the allowable current value since there is a current capacity limit according to I/O ON points.

The allowable current capacity of the internal power supply is 1.5A.

- Unit consumed current (When internal power supply is used) : 0.1 A

- Panel I/O JANCD-SP50-1, SP50-2 consumed current (When internal power is used)

Input current (1-point) : 5.1 mA (at ON)

Output current (1-point) : 60 mA max
(differs from load.)

- General-purpose I/O signal I/O module JANCD-FC810, FC860, FC861 consumed current

Input current (1-point) : 10.2 mA (at ON)

Output current (1-point) : 60 mA max
(differs from load.)

(Example of Calculation)

When JANCD-SP50-1 All I/O output are ON with LED load (2.7kΩ):

$5.1 \text{ mA} \times 64 = 326.4 \text{ mA}$ (JANCD-SP50-1 input consumed current)

$24 \text{ V} / 2.7 \text{ k} \times 32 = 28.4 \text{ mA}$ (JANCD-SP50-1 output consumed current)

$1500 \text{ mA} - 326 \text{ mA} - 284 \text{ mA} - 100 \text{ mA} = 790 \text{ mA}$ (possible supply current)

If the internal power supply is connected to JANCD-FC810 under these conditions, overcurrent alarm of the internal power supply (CPS18F) occurs to the input ON of 77 points or above.

$790 \text{ mA} / 10.2 \text{ mA} = 77 \text{ points}$

(2) Specifications of External Power Supply

Voltage : 24 VDC $\pm 5\%$

Ripple : 10% (P-P)

Provide external supply with the above.

18. CABLES

18.1 LIST OF CABLES

The interface cable are furnished with or without connectors.

Those cables shown in Table 18.1 are available.

If the machine builder is supplying the cables, prepare equivalent cables based on the cable specifications.

· Connector Cable Type

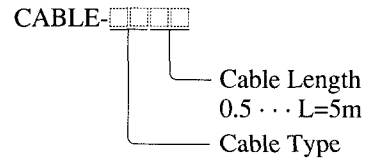

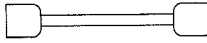
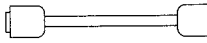



Table 18.1 List of Cables

Cable No.	CableType	Configuration	Remarks
(C12)	—	<p>(Type 10120-3000VE) (Type 10120-3000VE) (Type 10320-52A0-008) (Type 10320-52A0-008)</p> <p>UL 20276 AWG 28 × 10 pairs (Characteristic impedance: 120Ω)</p>	<ul style="list-style-type: none"> · I/O · CRT panel signal
(C32) (C34)	—	<p>(Type 10120-3000VE) (Type MRP-20M01(G)) (Type 10320-52A0-008) (Type MR-20L)</p> <p>UL 20276 AWG 28 × 10 pairs</p>	<ul style="list-style-type: none"> · Spindle drive unit feed back
(C30) (C31) (C33-1) (C36)	—	<p>(Type 10126-3000VE) (Type 10156-3000VE) (Type 10326-52A0-008) (Type 10350-52A0-008)</p> <p>UL 20276 AWG 28 × 13 pairs</p>	<ul style="list-style-type: none"> · Servo drive unit
(C33) (C35)	—	<p>(Type 10126-3000VE) (Type MRP-50F01) (Type 10320-52A0-008) (Type MR-50L)</p> <p>UL 20276 AWG 28 × 13 pairs</p>	<ul style="list-style-type: none"> · Spindle drive unit
(C300) (C310) (C330) (C360)	—	<p>(Type 10126-3000VE) (Type MS3108B20-29S) (Type 10326-52A0-008) (Type MS3057-12A)</p>	<ul style="list-style-type: none"> · Servomotor · Optical encoder
(C32-1) (C34-1)	—	<p>(Type 10120-3000VE) (Type MS3108B20-29S) (Type 10320-52A0-008) (Type MS3057-12A)</p> <p>UL 20276 AWG 28 × 10 pairs</p>	<ul style="list-style-type: none"> · Spindle optical encoder
(C101)	—	<p>(Type 10120-3000VE) (Type 10320-52A0-008)</p> <p>UL 20276 AWG 28 × 10 pairs</p>	<ul style="list-style-type: none"> · Manual pulse generator <p>CABLE-JK: LGF-011-100</p>

Table 18.1 List of Cables (Cont'd)

Cable No.	Cable Type	Configuration	Remarks
(C01)	—	Type 1-178288-5 Type 172026-1 	I/O Power supply
(C02) (C200)	—	Type 172026-1 Type 172026-1  Type VCT DE 8402398 2mm ² × 5 cores	I/O Power supply
(C10) (C11) (C20)	*	Connector : 10120-3000 VE 10320-52A0-008 Cable : UL 20276 AWG 28×10 cores	· Direct-IN · Closing sequence · RS-232C interface (Tape reader unit)
(C51) (C53) (C54) (C55) (C56) (C73)	*	Connector : MRP-50F01 MR-50L Cable : KQVV-SB DE 8400095 0.2 mm ² × 50 cores	I/O (FC810, FC861)
(C52)	*	Connector : MRP-20F01 MR-20L Cable : KQVV DE 6428673 0.2 mm ² × 20 cores	I/O (FC810)
(C03)	*	Connector : 172025-1 Cable : VCT DE 8402398 0.2 mm ² × 5 cores	AC power supply
(C13) (C130)	—	(Type MRP-8F01) (Type MRP-8F01) (Type MR-8L) (Type MR-8L)  KEV SB 0.2 × 1 core (Characteristic impedance: 120Ω)	I/O
(C320) (C340)	—	(Type MRP-20F01(G)) (Type MS3108B20-29S) (Type MR-20L) (Type MR3057-12A)  KQVV-SB DE 8400093 0.2 mm ² × 10 pairs	Spindle optical encoder connection
(C61) (C72) (C63) (C104) (C64) (C105) (C65) (C106) (C66) (C71)	*	Connector : FRC2-AA50-20S Cable : B-50S61.0M	I/O (FC860, FC861, SP50)
(C62)	*	Connector : FRC2-AA20-20S Cable : B-20S 60.0M	I/O (FC860)

* Conector and cable are separately provided.

18.2 SPECIFICATIONS OF CABLE

(1) Cable Dwg. No. DE8400093 (Type KQVV-SB, 0.2 mm² × 10 pairs)

Table 18.2 Construction

No. of Pairs		10
Conductor	Material	Tinned annealed - copper stranded wire
	Nominal Sectional Area mm ²	0.2
	No. of Conductors per mm	16/0.12
	Dimensions mm	0.55
Insulation	Material	Cross-linked vinyl
	Thickness mm	0.3
Winding		Paper tape lap winding Pitch: 18, 22, 25, 32
Shield		Tinned annealed copper stranded wire
Sheath	Material and Color	Vinyl, black
	Thickness mm	1.2
Finished Cable Diameter mm		10.0
Approx. Mass kg/km		130

Table 18.3 Characteristics

Max. Conduction Resistance (20°C)	Ω/km	113
Min. Insulation Resistance (20°C)	MΩ·km	50
Withstand Voltage	VAC/min	1000
Continuous Operation Temperature Range	°C	-30 to +60

Layout of 10 Pairs

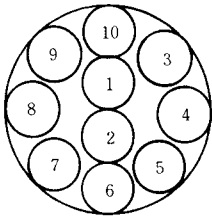

Pair No.	Colors
1	Blue/White
2	Yellow/White
3	Green/White
4	Red/White
5	Purple/White
6	Blue/Brown
7	Yellow/Brown
8	Green/Brown
9	Red/Brown
10	Purple/Brown

Note :
Drain wires of 0.2mm² are provided inside tinned annealed-copper stranded wire.

(2) Cable Dwg. No. DE8400095 (Type KQVV-SB, 0.2 mm² × 50 cores)

Table 18.4 Construction

No. of Cable Cores		50
Conductor	Material	Tinned annealed - copper stranded wire
	Nominal Sectional Area mm ²	0.2
	No. of Conductors per mm	16/0.12
	Dimensions mm	0.55
Insulation	Material	Cross-linked vinyl
	Thickness mm	0.3
Winding		Paper tape lap winding
Sheath	Material and Color	Soft Vinyl, black
	Thickness mm	1.2
Finished Cable Diameter mm		Approx. 13
Approx. Mass kg/cm		230

Table 18.5 Characteristics

Max. Conduction Resistance (20°C)	Ω/km	113
Min. Insulation Resistance (20°C)	MΩ·km	50
Withstand Voltage	VAC/min	1000
Continuous Operation Temperature Range	°C	-30 to +60

Details of Cable DWG.
No. DE8400095

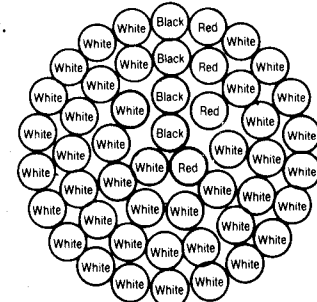

(3) Cable Dwg. No. DE6428673 (Type KQVV, 0.2 mm² × 20 cores)

Table 18.6 Construction

No. of Cable Cores		20
Conductor	Material	Tinned annealed - copper stranded wire
	Nominal Sectional Area mm ²	0.2
	No. of Conductors per mm	16/0.12
	Dimensions mm	0.55
Insulation	Material	Cross-linked vinyl
	Thickness mm	0.3
Winding		Paper tape lap winding
Sheath	Material and Color	Soft Vinyl, black
	Thickness mm	1.2
Finished Cable Diameter mm		8.0
Approx. Mass kg/cm		90

Table 18.7 Characteristics

Max. Conduction Resistance (20°C)	Ω/km	113
Min. Insulation Resistance (20°C)	MΩ-km	50
Withstand Voltage	VAC/min	1000
Continuous Operation Temperature Range	°C	-30 to +60

Details of Cable Dwg.
No. DE6428673

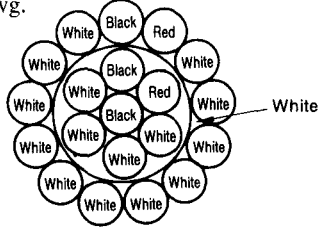

(4) Cable Dwg. No. DE8402398 (Type VCT, 2 mm² × 5 cores)

Table 18.8 Construction

No. of Pairs		5
Conductor	Material	Tinned annealed copper stranded wire
	Nominal Sectional Area mm ²	2.0
	No. of Conductors per mm	37/0.26
	Dimensions mm	1.8
Insulation	Material	Insulation vinyl
	Thickness mm	0.8
	Diameter mm	3.4
Stranding		Right twisted (outer diameter: approx. 9.2 mm)
Sheath	Material and Color	Vinyl, black
	Thickness mm	Approx. 1.9
Finished Cable Diameter mm		Approx. 13.0

Table 18.9 Characteristics

Max. Conduction Resistance (20°C)	Ω/km	10.2
Min. Insulation Resistance (20°C)	MΩ-km	50 or more
Withstand Voltage	VAC/min	3000
Continuous Operation Temperature Range	°C	0 to +60

Details of Cable Dwg. No. DE8402398

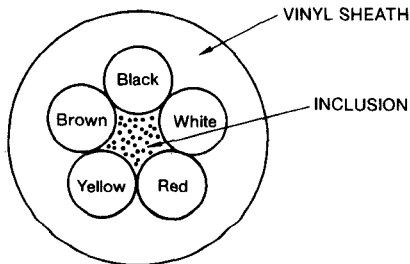

18.3 LIST OF CONNECTORS

(1) CNC UNIT

Table 18.10 Connectors for CNC Unit

CNC Unit Type	Connector No.	Connector Type for Board Side	Cable Side			
			Connector Type	Case Type	Contact Type	Manufacturer
CPS-18FB	CN1	172040-1 (5 pins)	172026-1	—————	170289-1 170289-1 or 170289-1	AMP
	CN2	172040-1 (5 pins)	172026-1	—————		
	CN3	172039-1 (7 pins)	172025-1	—————		
JANCD-SR 50-1	CN30	10226-52 A 2 JL (26 pins)	10126-3000 VE (10126-6000 EL)	10326-52 A 0-008 (10326-A200-00)	—————	3M
	CN31	10226-52 A 2 JL (26 pins)	10126-3000 VE (10126-6000 EL)	10326-52 A 0-008 (10326-A200-00)	—————	
	CN32	10220-52 A 2 JL (20 pins)	10120-3000 VE (10120-6000 EL)	10320-52 A 0-008 (10320-A200-00)	—————	
	CN33	10226-52 A 2 JL (26 pins)	10126-3000 VE (10126-6000 EL)	10326-52 A 0-008 (10326-A200-00)	—————	
JANCD-SR 50-2	CN30	10226-52 A 2 JL (26 pins)	10126-3000 VE (10126-6000 EL)	10326-52 A 0-008 (10326-A200-00)	—————	3M
	CN31	10226-52 A 2 JL (26 pins)	10126-3000 VE (10126-6000 EL)	10326-52 A 0-008 (10326-A200-00)	—————	
	CN33	10226-52 A 2 JL (26 pins)	10126-3000 VE (10126-6000 EL)	10326-52 A 0-008 (10326-A200-00)	—————	
	CN34	10226-52 A 2 JL (26 pins)	10120-3000 VE (10120-6000 EL)	10320-52 A 0-008 (10320-A200-00)	—————	
	CN35	10226-52 A 2 JL (26 pins)	10126-3000 VE (10126-6000 EL)	10326-52 A 0-008 (10326-A200-00)	—————	
JANCD-SR 50-3	CN30	10226-52 A 2 JL (26 pins)	10126-3000 VE (10126-6000 EL)	10326-52 A 0-008 (10326-A200-00)	—————	3M
	CN31	10226-52 A 2 JL (26 pins)	10126-3000 VE (10126-6000 EL)	10326-52 A 0-008 (10326-A200-00)	—————	
	CN32	10220-52 A 2 JL (20 pins)	10120-3000 VE (10120-6000 EL)	10320-52 A 0-008 (10320-A200-00)	—————	
	CN33	10226-52 A 2 JL (26 pins)	10126-3000 VE (10126-6000 EL)	10326-52 A 0-008 (10326-A200-00)	—————	
	CN34	10220-52 A 2 JL (20 pins)	10120-3000 VE (10120-6000 EL)	10320-52 A 0-008 (10320-A200-00)	—————	
	CN35	10226-52 A 2 JL (26 pins)	10126-3000 VE (10126-6000 EL)	10326-52 A 0-008 (10326-A200-00)	—————	
JANCD-SR 51	CN36	10226-52 A 2 JL (26 pins)	10126-3000 VE (10126-6000 EL)	10326-52 A 0-008 (10326-A200-00)	—————	3M
JANCD-CP 50	CN20	10220-52 A 2 JL (20 pins)	10120-3000 VE (10120-6000 EL)	10320-52 A 0-008 (10320-A200-00)	—————	3M
JANCD-PC 50	CN10	10220-52 A 2 JL (20 pins)	10120-3000 VE (10120-6000 EL)	10320-52 A 0-008 (10320-A200-00)	—————	3M
	CN11	10220-52 A 2 JL (20 pins)	10120-3000 VE (10120-6000 EL)	10320-52 A 0-008 (10320-A200-00)	—————	3M
	CN12	10220-52 A 2 JL (20 pins)	10120-3000 VE (10120-6000 EL)	10320-52 A 0-008 (10320-A200-00)	—————	3M
	CN13	MR-8RMA 4 (8 pins)	MRP-8F01	MR-8L	MRP-F112	HONDA
JANCD-MM 51	No connector is provided					

Note :

Connectors for the cable side are not attached to the cables.
The machine builder must supply equivalent connectors.

Connector Position
JZNC-JRK 00

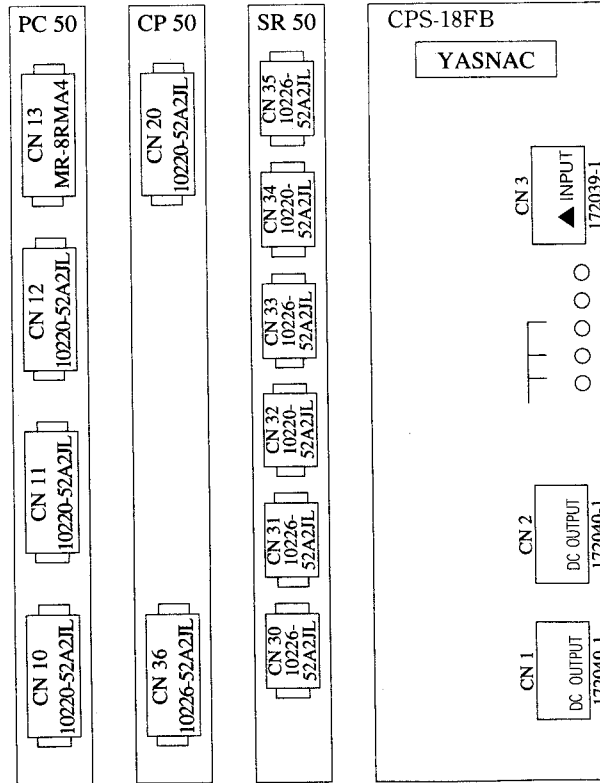

Fig. 18.1 Connector Layout (JZNC-JRK00)

(2) CNC Operator's Panel

Table 18.11 Connectors for CNC Operator's Panel

CNC Panel Type	Connector No.	Connector Type for Board Side	Cable Side			
			Connector Type	Case Type	Contact Type	Manufacturer
JANCD-SP 50-1	CN1	10220-6202JL (20 pins)	10120-3000 VE (10120-6000 EL)	10320-52 A 0-008 (10326-A200-00)	_____	3M
JANCD-SP 50-2	CN2	10220-6202JL (20 pins)	10120-3000 VE (10120-6000 EL)	10320-52 A 0-008 (10326-A200-00)	_____	3M
	CN3	1-178315-2 (5 pins)	1-178288-5	_____	175218-2	AMP
	CN4	FRC2-C50S12-0S (50pins)	FRC2-AA 50-20	_____	_____	DDK
	CN5	FRC2-C50S12-0S (50pins)	FRC2-AA 50-20	_____	_____	DDK
	CN6	FRC2-C50S12-0S (50pins)	FRC2-AA 50-20	_____	_____	DDK

Note :

Connectors for the cable side are not attached to the cables.

The machine builder must supply equivalent connectors.

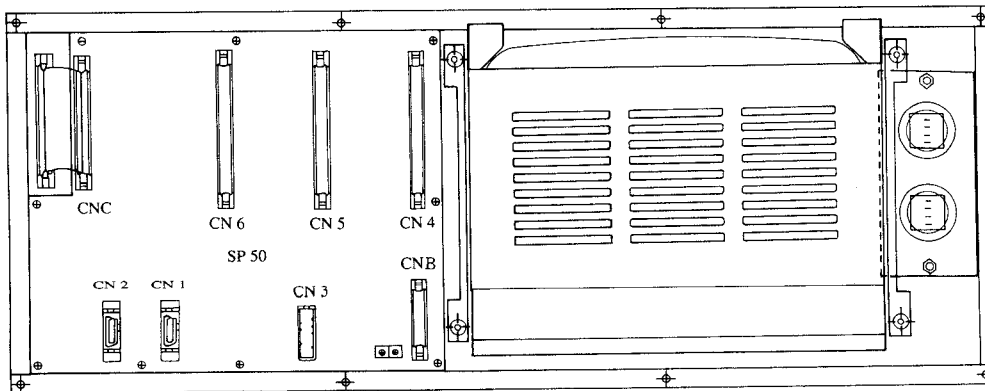

Fig. 18.2 Connector Layout of CNC Operator's Panel (Type JANCD-SP50-1, -2)

(3) I/O Module Connector

Table 18.12 Connectors for I/O Module

I/O Module Type	Connector No.	Connector Type for Board Side	Cable Side				
			Connector Type	Case Type	Contact Type	Manufacturer	
JANCD-FC810	CN1	MR-50 RMD 2 (50 pins)	MRP-50F 01	MR-50L	MRP-F112	HONDA	
	CN2	MR-20 RMD 2 (20 pins)	MRP-20F 01	MR-20L	MRP-F112	HONDA	
	CN3	MR-50 RMD 2 (50 pins)	MRP-50F 01	MR-50L	MRP-F112	HONDA	
	CN4	MR-50 RMD 2 (50 pins)	MRP-50F 01	MR-50L	MRP-F112	HONDA	
	CN5	MR-50 RMD 2 (50 pins)	MRP-50F 01	MR-50L	MRP-F112	HONDA	
	CN6	MR-50 RMD 2 (50 pins)	MRP-50F 01	MR-50L	MRP-F112	HONDA	
	CN11	MR-8 RMA 4 (8 pins)	MRP-qF 01	MR-8L	MRP-F112	HONDA	
	CN12	MR-8 RMA 4 (8 pins)	MRP-qF 01	MR-8L	MRP-F112	HONDA	
	CN13	172040-1 (5 pins)	172026-1	_____	170289-1	AMP	
	CN14	172040-1 (5 pins)	172026-1	_____	170289-1	AMP	
	JANCD-FC860	CN1	FRC2-C50S12-0L (50 pins)	FRC2-AA 50-20S	_____		DDK
		CN2	FRC2-C20S12-0L (20 pins)	FRC2-AA 20-20S	_____		DDK
		CN3	FRC2-C50S12-0L (50 pins)	FRC2-AA 50-20S	_____		DDK
		CN4	FRC2-C50S12-0L (50 pins)	FRC2-AA 50-20S	_____		DDK
CN5		FRC2-C50S12-0L (50 pins)	FRC2-AA 50-20S	_____		DDK	
CN6		FRC2-C50S12-0L (50 pins)	FRC2-AA 50-20S	_____		DDK	
CN11		MR-8RMD 2 (8 pins)	MRP-8F01	MR-8L	MRP-F112	HONDA	
CN12		MR-8RMD 2 (8 pins)	MRP-8F01	MR-8L	MRP-F112	HONDA	
CN13		172037-1 (5 pins)	172026-1	_____	170289-1	AMP	
CN14		172037-1 (5 pins)	172026-1	_____	170289-1	AMP	
JANCD-FC861		CN1	FRC2-C50S12-0L (50 pins)	FRC2-AA 50-20S	_____		DDK
		CN2	FRC2-C50S12-0L (20 pins)	FRC2-AA 20-20S	_____		DDK
		CN3	MR-50 RMD 2 (50 pins)	MRP-50F01	MR-50L	MRP-F112	HONDA
		CN11	MR-8 RMA 2 (8 pins)	MRP-8F01	MR-8L	MRP-F112	HONDA
	CN12	MR-8 RMA 2 (8 pins)	MRP-8F01	MR-8L	MRP-F112	HONDA	
	CN13	172037-1 (5 pins)	172060-1	_____	170289-1	AMP	
	CN14	172037-1 (5 pins)	172060-1	_____	170289-1	AMP	
	CN15	1-178313-2 (3 pins)	1-178288-3	_____	175217-2	AMP	

Note :
 Connectors for the cable side are not attached to the cables.
 The machine builder must supply equivalent connectors.

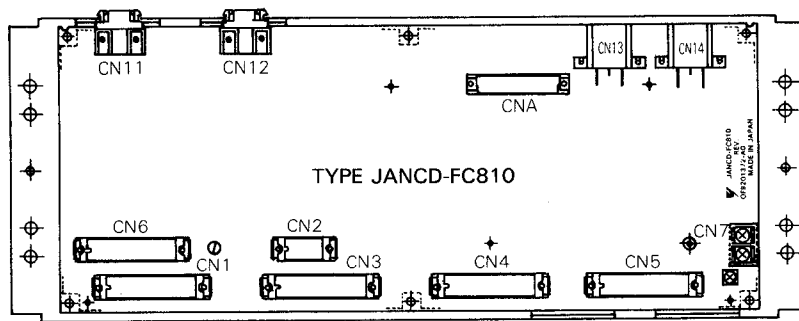

Fig. 18.3 Connector Layout of I/O Module (JANCD-FC810)

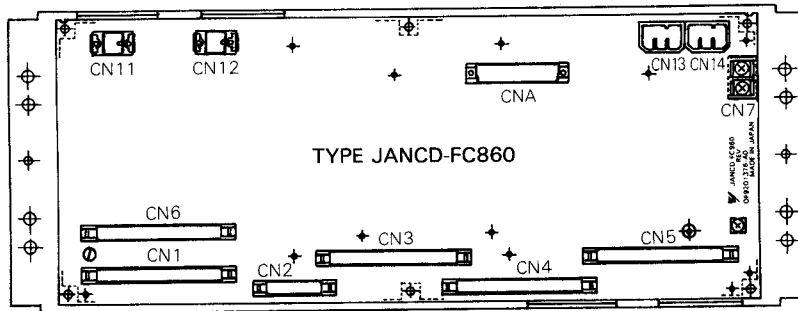

Fig. 18.4 Connector Layout of I/O Module (JANCD-FC860)

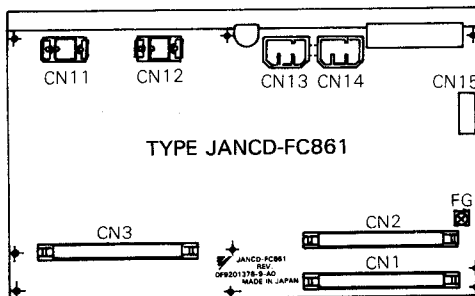

Fig. 18.5 Connector Layout of I/O Module (JANCD-FC861)

(4) Drive Unit

Table 18.13 Connectors for Drive Unit

Unit Type	Connector No.	Connector Type for Board Side	Cable Side			
			Connector Type	Case Type	Contact Type	Manufacturer
SGDB-□AD□	CN1	10250-52A2JL (50 pins)	10150-3000VE	10350-52A0-008	————	3M
	CN2	10220-52A2JL (20 pins)	10120-3000VE	10320-52A0-008	————	3M
CIMR-VM3□□	1CN	MR-50 RMA(G) (50 pins)	MRP-50 F01 (G)	MR-50L	————	HONDA
	2CN	MR-20 RFA(G) (20 pins)	MRP-20 M01 (G)	MR-20L	————	HONDA
	3CN	MR-20 RMA(G) (20 pins)	MRP-20 F01 (G)	MR-20L	————	HONDA

Note :

Connectors for the cable side are not attached to the cables.

The machine builder must supply equivalent connectors.

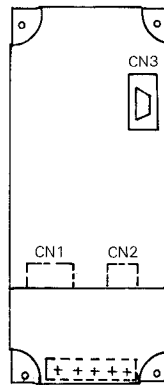

(a) SGDB-□AD□

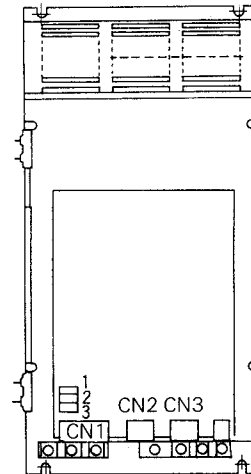

(b) CIMR-VM3

Fig. 18.6 Connector Layout of Drive Unit

18.4 SHORTING PIN SETUPS

JANCD-CP50

SW1 : System number switch (16-position rotary switch)

- SW1 [0] - Normal operation mode
- [1] - Parameter change mode
- [4] - Ladder edit mode

Note :

Positions [2], [3], and [5] through [F] of switch SW1 are for maintenance use only.

No one should be allowed to use these switch positions except a qualified YASKAWA representative.

JANCD-PC50

Panel switch ON function selector switch

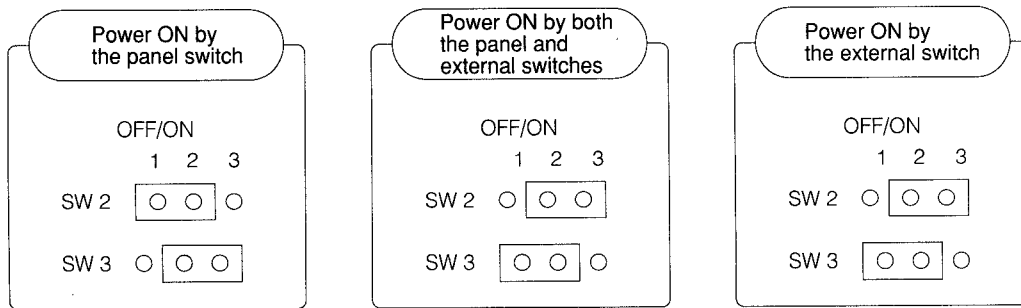

JANCD-SR50-1 (-2) (-3), SR51

D/A voltage adjustment trimmers : Factory-adjusted prior to shipment. No further adjustments are needed.

<SR 50-1>

- VR1: First servo axis zero adjustment
- VR2: First servo axis gain adjustment
- VR3: Second servo axis zero adjustment
- VR4: Second servo axis gain adjustment
- VR5: First spindle zero adjustment
- VR6: First spindle gain adjustment

<SR50-2, -3>

- VR1: First servo axis zero adjustment
- VR2: First servo axis gain adjustment
- VR3: Second servo axis zero adjustment
- VR4: Second servo axis gain adjustment
- VR5: Third servo axis (first spindle) zero adjustment
- VR6: Third servo axis (first spindle) gain adjustment
- VR7: Second spindle zero adjustment
- VR8: Second spindle gain adjustment

<SR51>

- VR1: Third (forth) servo axis zero adjustment
- VR2: Third (forth) servo axis gain adjustment

I/O address of I/O port (SP50, FC861, FC810, FC860) each module can be set by rotary switch (SW1).

For details, refer to Appendix B.

19. J50L STANDARD I/O SIGNALS

19.1 LIST OF NC STANDARD I/O SIGNALS

Standard input/output signals are listed below.

For custom-built signals depending on the system, refer to the list of I/O signals provided for that particular system.

DISPLAY

D7 D6 D5 D4 D3 D2 D1 D0
 0 0 0 0 1 1 1 1

↑
Contact open

↑
Contact closed

Input Signals (PLC→NC)

	D7	D6	D5	D4	D3	D2	D1	D0
#1300	EDT EDIT	MEM MEMORY	MDI MANUAL DATA INPUT	T TAPE		H/S HANDLE/STEP	J MANUAL JOG	RPD MANUAL RAPID TRAVERSE
#1301	MP 1	ROV 2	ROV 1	FV 16	FV 8	FV 4	FV 2	FV 1
	RAPID SPEED OVERRIDE			FEEDRATE OVERRIDE/MANUAL JOG SPEED				
#1302	HZ	HX	-Z	+Z	-X	+X	MP 4	MP 2
	MANUAL PG AXIS SELECT		MANUAL TRAVERSE AXIS DIRECTION SELECT			MANUAL PG MULTIPLY SELECT		
#1303	INHEDT INHIBIT EDIT	AFL M.S.T LOCK	ABS MANUAL ABS.	DRN DRY RUN	BDT BLOCK DELETE	DLK DISPLAY LOCK	MLK MACHINE LOCK	SBK SINGLE BLOCK
#1304	ZRN RETURN TO REFERENCE	CDZ THREAD CUT UP	SMZ ERROR DETECT ON	RWDH HIGH-SPEED REWIND	SRN SET UP POINT RETURN	PST CURRENT POSITION SET	*SP FEED HOLD	ST CYCLE START
#1305	ERR1	ERR0	STLK	RWD	EOP	ERS	FIN	MRD
	EXTERNAL ERROR INPUT		INTER-LOCK START	REWIND	END OF PROGRAM	EXTERNAL RESET	MST COMPLETED	MACHINE READY
#1306	SAGR SPINDLE SPEED AGREEMENT		*DCZ	*DCX	*-LZ	*+LZ	*-LX	*+LX
		DECREASE INPUT FOR REFERENCE POINT			OVERTRAVEL INPUT			
#1307	GRS	GSC	SSTP	SINV	GR 4	GR 3	GR 2	GR 1
	DURING GEAR SHIFT	SPINDLE SPEED CONSTANT	SPINDLE COMMAND "0"	SPINDLE COMMAND INVERT	SPINDLE GEAR RANGE SELECT			
#1308	EOUT	EVER	EIN	DRSZ	DRSX			EXTC
	NC PROGRAM PUNCH OUT	NC PROGRAM VERIFY	NC PROGRAM STORE	DISPLAY RESET				TIME COUNT
#1309	BDT 9	BDT 8	BDT 7	BDT 6	BDT 5	BDT 4	BDT 3	BDT 2
	OPTIONAL BLOCK DELETE							

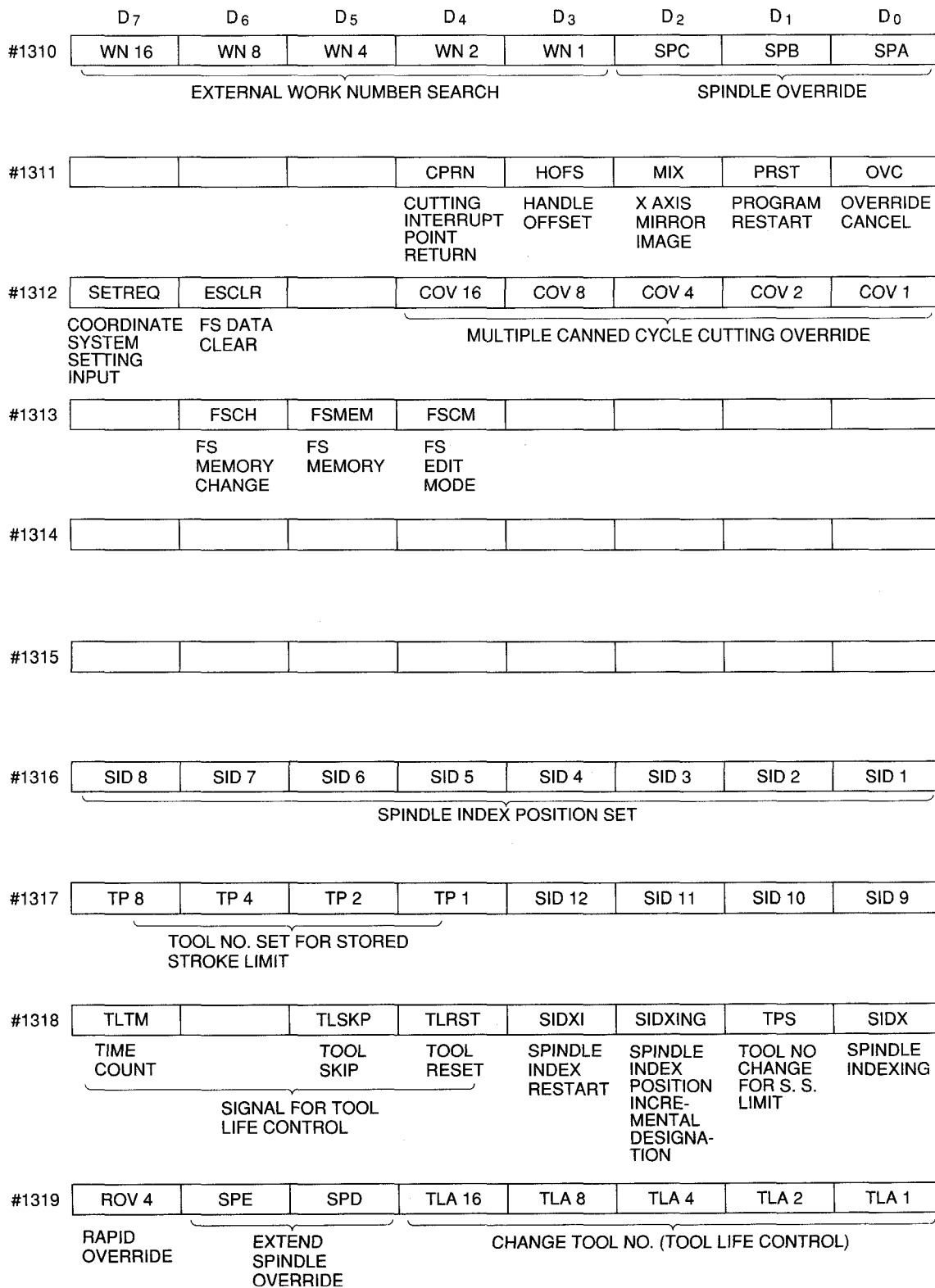

19.1 LIST OF NC STANDARD I/O SIGNALS (Cont'd)

Input Signals (PLC→NC)

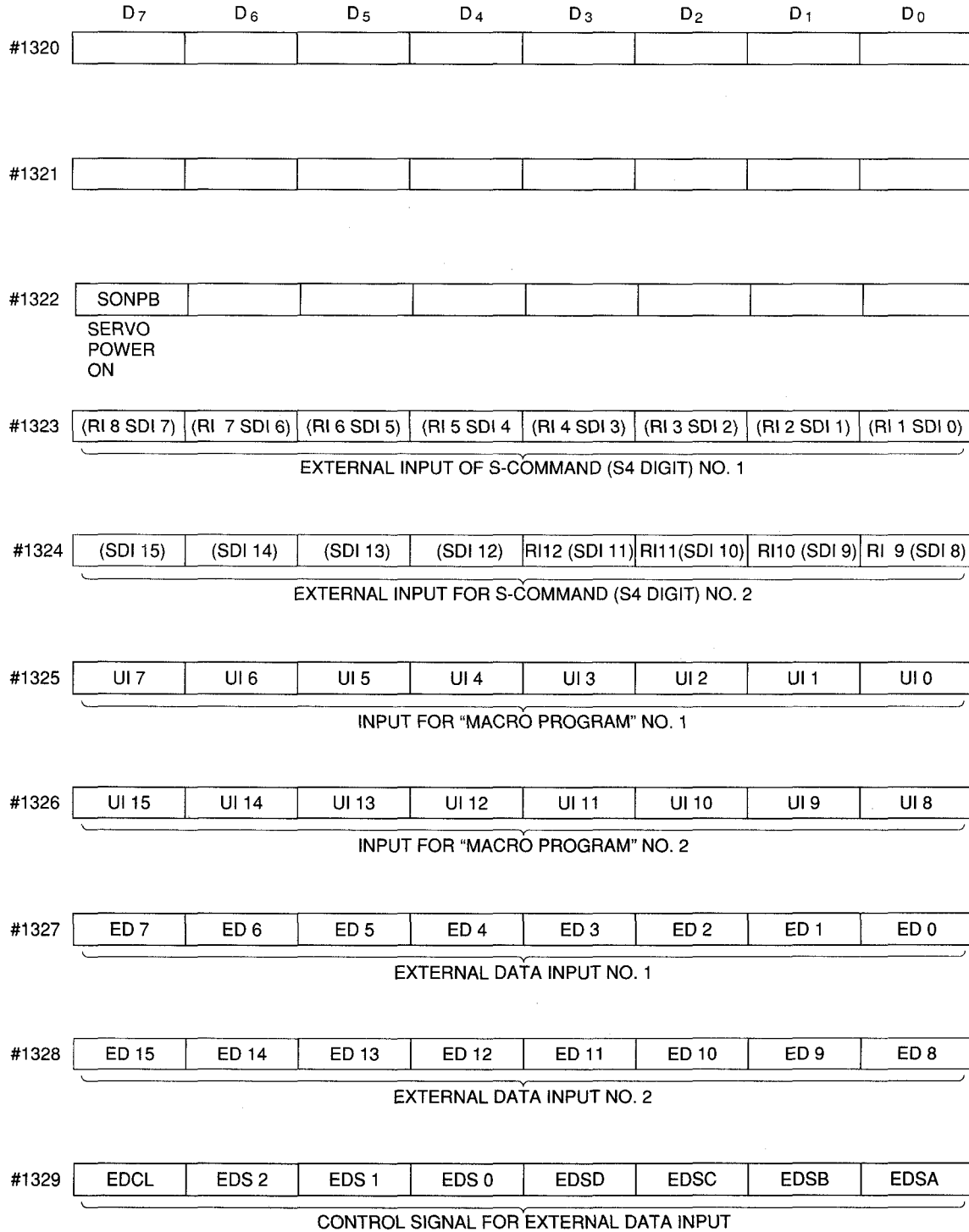

Output Signals (NC→PLC)

	D ₇	D ₆	D ₅	D ₄	D ₃	D ₂	D ₁	D ₀
#1200	M 28	M 24	M 22	M 21	M 18	M 14	M 12	M 11
	M FUNCTION BCD OUTPUT							
#1201	M 30 R	M 02 R	M 01 R	M 00R	M 38	M 34	M 32	M 31
	M 30 DECODE OUTPUT	M 02 DECODE OUTPUT	M 01 DECODE OUTPUT	M 00 DECODE OUTPUT				
#1202	TF	SF	MF	SINVA	IER	*ESPS	RST	ALM
	T-FUNC- TION SAMPL- ING OUTPUT	S-FUNC- TION SAMPL- ING OUTPUT	M-FUNC- TION SAMPL- ING OUTPUT	S4 DIGIT OUT INVERT STATUS	INPUT ERROR OUTPUT	EMERGENCY STOP OUTPUT	RESET OUT- PUT	ALARM OUTPUT
#1203		EDTS	AUTO	MAN	THC	RWDS	OP	DEN
		EDIT OPERAT- ING STATUS	AUTO MODE STATUS	MANUAL MODE STATUS	THREAD CUTTING STATUS	REWIND STATUS	FEEDING	POSITION- ING END
#1204	S 28	S 24	S 22	S 21	S 18	S 14	S 12	S 11
	S-FUNCTION BCD OUTPUT							
#1205	T 28	T 24	T 22	T21	T 18	T 14	T 12	T 11
	T-FUNCTION BCD OUTPUT							
#1206	2 ZPZ	2 ZPX	ZPZ	ZPX			SPL	STL
	Z AXIS NO.2 REFERENCE POSITION	X AXIS	Z AXIS REFERENCE POSITION	X AXIS			FEED HOLD LAMP	CYCLE START LAMP
#1207								
#1216	R 08 (SDO 7)	R 07 (SDO 6)	R 06 (SDO 5)	R 05 (SDO 4)	R 04 (SDO 3)	R 03 (SDO 2)	R 02 (SDO 1)	R 01 (SDO 0)
	EXTERNAL OUTPUT FOR S-COMMAND (S4 DIGIT) NO. 1							
#1217	(SDO 15)	(SDO 14)	(SDO 13)	(SDO 12)	RO 12(SDO11)	RO 11(SDO10)	RO10(SDO9)	R 09(SDO8)
	EXTERNAL OUTPUT FOR S-COMMAND (S 4 DIGIT) NO. 2							
#1218				FSCE	FSMD		ASF	G 96 S
				FS MEMORY CHANGE END	DURING FS EDIT MODE		S-COMMAND (S 4 DIGIT) ANALOG SF	CONSTANT SURFACE SPEED CONTROL

19.1 LIST OF NC STANDARD I/O SIGNALS (Cont'd)

Input Signals (NC→PLC)

	D7	D6	D5	D4	D3	D2	D1	D0
#1219	ESEND	EREND		SETEND	TLCH	SIDXO	TRSA	SIDXA
	EXTERNAL DATA SEARCH COMPLETION	EXTERNAL DATA INPUT COMPLETION		COORDINATE SYSTEM SETTING END	TOOL CHANGE COMMAND (TOOL LIFE CONTROL)	SPINDLE INDEX EXECUTING	STORED STROKE LIMIT AREA CHANGE END	SPINDLE INDEX END

#1220	UO 7	UO 6	UO 5	UO 4	UO 3	UO 2	UO 1	UO 0
OUTPUT FOR "MACRO PROGRAM" NO. 1								

#1221	UO 15	UO 14	UO 13	UO 12	UO 11	UO 10	UO 9	UO 8
OUTPUT FOR "MACRO PROGRAM" NO. 2								

#1222								
-------	--	--	--	--	--	--	--	--

#1223					FSC LRE			
FS DATA CLEAR END								

#1224	MD 7	MD 6	MD 5	MD 4	MD 3	MD 2	MD 1	MD 0
HIGH-SPEED M-FUNCTION								

Monitor Signals

#1280	SSW 3	SSW 2	SSW 1	SSW 0				SKIP
SYSTEM NUMBER SWITCH								SKIP INPUT

#1281	0	* OFFPB		ONPB	* OLD	SVAM	* ESP	* OHT
		POWER OFF PB.		POWER ON PB	OVER-LOAD	SERVO ALARM	EMERGENCY STOP	OVER-HEAT

#1282	1 HP 7	1 HP 6	1 HP 5	1 HP 4	1 HP 3	1 HP 2	1 HP 1	1 HP 0
MANUAL PULSE GENERATOR MONITOR								

#1283					SET 3	SET 2	SET 1	SET 0
# 6219 MONITOR								

#1284	SVMX	SVMX						
SERVO POWER ON (= "NRD")								

#1285	0	0	0	0	0	0	0	1
CONSTANT "1"								

	D ₇	D ₆	D ₅	D ₄	D ₃	D ₂	D ₁	D ₀
#1286	0	0	0	0	0	0	0	0
	CONSTANT "0"							
#1287		PCS	PBS	PAS				
		PHASE-C	PHASE-B	PHASE-A				
	SPINDLE PG FEED BACK MONITOR							
#1288	TGONX	PCY	PBX	PAX	*ALX	*OLX	FUX	SRDX
	X-AXIS TGON	PHASE-C	PHASE-B	PHASE-A	MONITOR FOR SERVO UNIT OF X-AXIS			
	X-AXIS PG FEED BACK MONITOR							
#1289	TGONZ	PCZ	PBZ	PAZ	*ALZ	*OLZ	FUZ	SRDZ
	Z-AXIS TGON	PHASE-C	PHASE-B	PHASE-A	MONITOR FOR SERVO UNIT OF Z-AXIS			
	Z-AXIS PG FEED BACK MONITOR							
#1290	SCOM 28	SCOM 24	SCOM 22	SCOM 21	SCOM 18	SCOM 14	SCOM 12	SCOM 11
	S-COMMAND MONITOR							
#1291	SCOM 48	SCOM 44	SCOM 42	SCOM 41	SCOM 38	SCOM 34	SCOM 32	SCOM 31
	S-COMMAND MONITOR							
#1292	SO 28	SO 24	SO 22	SO 21	SO 18	SO 14	SO 12	SO 11
	SPINDLE OUTPUT MONITOR							
#1293	SO 48	SO 44	SO 42	SO 41	SO 38	SO 34	SO 32	SO 11
	SPINDLE OUTPUT MONITOR							
#1294	ALM 28	ALM 24	ALM 22	ALM 21	ALM 18	ALM 14	ALM 12	ALM 11
	ALARM OUTPUT MONITOR							
#1295					ALM 38	ALM 34	ALM 32	ALM 31
	ALARM CODE MONITOR							
#1296	INHEDTT	AFLT	ABST	PRNT	BDTT	DLKT	MLKT	SBKT
	#6000 MONITOR							

19.2 DETAILS OF SIGNALS

19.2.1 INPUT SIGNALS FOR CYCLE START (ST), STOP (*SP) OUTPUT SIGNALS DURING CYCLE START (STL) AND FEEDHOLD (SPL)

- (1) With the control in any of the TAPE, MEMORY, and MDI modes, when the input contact ST is closed, the control starts automatic operation control to execute the part program, and at the same time, turn on the STL output signal for cycle start. However, an ST input is neglected under the following condition.
 - While the control is in an alarm state.
(While an alarm output or an input error output is on.)
 - While the feedhold *SP input contact is open.
 - While the external reset ERS input contact is closed.
 - While the RESET button on the MDI & CRT panel is being pushed.
 - While the system No. switch is in any state except for 0 and 4.
- (2) When the following state is entered after cycle start, the control completes operation control, and turns off the STL output.
 - When a part program has been executed by manual data input in the MDI mode.
 - When one block of a part program has been executed with the single block (SBK) input contact closed.
 - When the program end (EOP) input contact has been closed by an M command of a part program.
- (3) When the feedhold input contact “*SP” is opened during automatic operation, the automatically controlled motions, etc. are interrupted, and at the same time the cycle start output STL is turned OFF and the feedhold output SPL is turned ON. While a block of thread cutting instruction is being executed, the feedhold input is neglected, unless the control is equipped with Thread Interruption function.
- (4) When the feedhold input contact *SP is closed, and cycle start input contact ST is closed, temporary stop SPL is turned OFF, and automatic operation is restarted. The cycle start output STL is turned ON also.

Timing chart for input of cycle start (ST), feedhold (*SP), and cycle start (STL) and temporary stop (SPL) is shown in Fig. 19.1.

*Asterisked signals activate at LOW.
(Normally closed contacts)

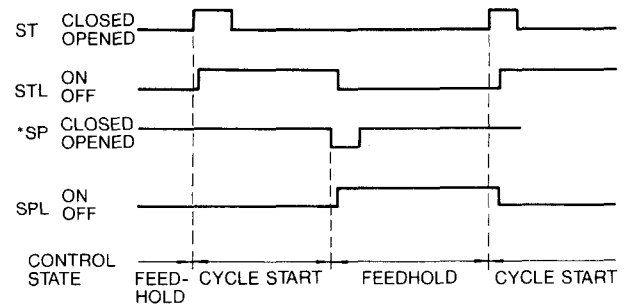

Fig. 19.1

Notes :

1. Be sure to keep the cycle start (ST) and feedhold (*SP) input contacts closed or open at least for 100 ms. If the duration is shorter than this, the input may sometimes be neglected.
2. The operation of the cycle start (ST) input contact is reversed by parameter STUD (#6007D6).
When the parameter is set to 1, the closing of the contact will start the operation of the control.
3. When the feedhold (*SP) input contact is opened, with the control waiting for the completion of the M, S, T, instruction (waiting for FIN input) feedhold (SPL) output is turned on, but when the M, S, T instruction completion (FIN) input contact is opened, the feedhold (SPL) output is turned off, and the control enters feedhold state.

19.2.2 INPUT AND OUTPUT FOR CONTROL OPERATION MODES (JOG, H/S, T, MDI, MEM, EDT, AUT, MAN)

(1) Operation Mode Input

The following six operation modes of the control are selected by the respective input contacts.

JOG:	Manual jog mode	}	Manual operation
H/S:	Manual handle/manual step feed mode		
T:	Tape operation mode	}	Automatic operation mode
MDI:	Manual data input operation mode		
MEM:	Memory operation mode		
EDT:	Program editing mode		

When any the input contacts is closed, the corresponding operation modes is tuned on.

JOG: manual jog mode input

When the JOG input contact is closed, and other mode input contacts are opened, the control enters the manual jog mode, and the machine is jogged in the respective directions in response to the input of +X, -X, +Z and -Z signals.

H/S: Manual handle/manual step feed mode input

When the H/S input contact is closed, and other mode input contacts are opened, the control enters the manual handle mode (when the control is provided with an optional manual pulse generator) or the manual step feed mode, and the machine will be manually fed by the manual pulse generator or fed in steps.

T: Tape operation mode

When the T input contact is closed and other mode input contacts are opened, the control enters the tape operation mode, and the machine will be controlled by the tape commands read by the tape reader.

MDI: Manual data input operation mode input

When the MDI input contact is closed, and other mode input contacts are opened, the control enters the manual data input mode, and part programs will be written or the machine will be operated through MDI.

MEM: Memory operation mode input

When the MEM input contact is closed, and other mode input contacts are opened, the control enters the memory operation mode, and the machine will be controlled by part programs stored in the memory.

EDT: Program edit mode

When the EDT input contact is closed and other operation mode input contacts are open, the control enters the program edit mode, and it can store part programs into the memory, correct and change them.

(2) Operation Mode Output

The control outputs the following signals to inform the current operation mode.

AUT: Automatic operation mode output

This output signal is turned on when the control is in the T (tape operation), MEM (memory operation), or MDI (manual data input operation) mode.

MAN: Manual operation mode output

This output signal is turned on when the control is in the H/S (manual handle/manual step operation mode) or JOG (manual jog mode.)

EDTS: Editing output

This output signal is turned on when the control is in the EDT (program editing) mode, and also performing and editing operation (part program reading, collation, punching, and stored program changing and other processing).

Timing chart for input and output for control operation modes are shown in Fig. 19.2

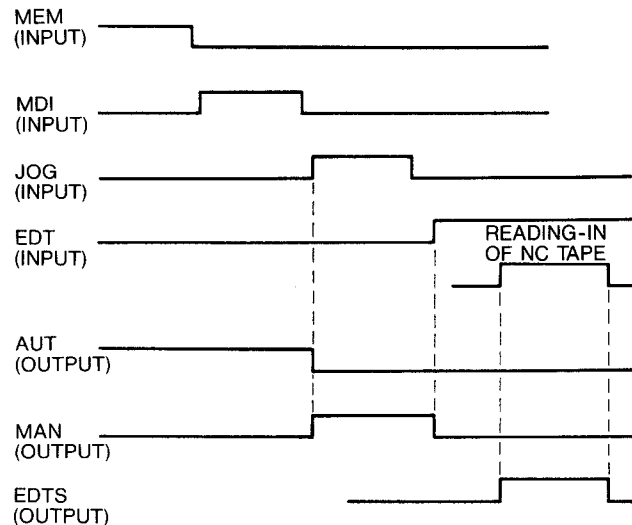

Fig. 19.2

Notes :

1. When any operation-mode-input except manual operation mode is given during NC program operation in the memory operation mode, the control stops the execution of the part program after the execution of the current block. The same applies to the part program operation in the tape and MDI modes.
2. When a manual-operation-mode-input contact is closed during the execution of a part program in the memory operation mode, the following changes take place.
 - Motion command
The current motion stops after deceleration, and the program is interrupted. The remaining program can be restarted when the automatic operation mode is turned on again and the cycle start (ST) input contact is closed.
 - M, S, T command
The sampling outputs (MF, SF, TF) and the M code outputs are turned off, and the M, S, T command is regarded to have been executed completely.
Even when the control is returned to the automatic operation mode, the interrupted M, S, T command is not resumed.
The above applies to S2-digit commands. S4-digit commands do not have sampling output.
3. When an automatic operation mode or program editing mode input contact is closed during motion in the manual operation mode, the motion decelerates and stops.
4. When any of these operation mode input contacts is closed, that mode becomes effective. Under other input states, the previous operation mode remains effective. When no operation-mode-input-contact is closed after the energization, or when two or more operation mode input contacts are closed, the control enters the manual jog mode.

19.2.2 INPUT AND OUTPUT FOR CONTROL OPERATION MODES (JOG, H/S, T, MDI, MEM, EDT, AUT, MAN) (Cont'd)

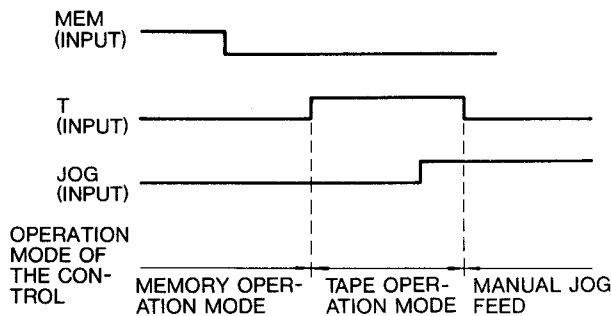

Fig. 19.3

- When a manual operation mode input contact is closed during the thread-cutting process in a part program, the automatic operation mode is retained while the thread is being cut.

19.2.3 MANUAL RAPID TRAVERSE SELECTION (RPD) INPUT

When the RPD input contact is closed while the control is in the manual jog mode, manual feeding in the +X, -X, +Z and -Z directions is performed in the rapid traverse rate.

After power supply is input, JOG feed rate can be used as RPD feed rate by parameter (#6009D3=1) until reference point return for each axis has been executed completely.

19.2.4 MANUAL HANDLE FEED AXIS SELECTION (HX, HZ) INPUT, AND AUTOMATIC MODE HANDLE OFFSET (HOFS) INPUT

(1) Manual Handle Feed Axis Selection (HX, HZ) Input

This is the input signal for selecting the motion axis for the motion by the manual pulse generator, with a control provided with a manual pulse generator. When the HX input contact is closed and the HZ input contact is open, the motion takes place along the X-axis. When the HZ input contact is closed and the HX input contact is open, the motion takes place along the Z-axis.

Notes :

- When both the HX and HZ input contacts are closed or open, motion cannot be obtained by the manual pulse generator.
- When the control is provided with a pulse generator for simultaneous 2-axis control, and when a manual step feed is intended, these input contacts are not used.

(2) Automatic Mode Handle Offset (HOFS) Input

This input is for enabling motion control with the manual handle even during the automatic operation mode (Tape mode, MDI mode, memory mode) with a control provided with a manual pulse generator.

With this input, relative displacements caused by the remounting of the workpieces during automatic operation can be compensated.

When the HOFS input contact is closed, the motion control by the manual pulse generator is effective even during the automatic operation mode. However, during the execution of a positioning command in the automatic operation mode, machine motion cannot be controlled by the manual pulse generator.

The motion axis for the manual pulse generator motion control is selected by the HX and HZ (manual handle feed axis selection) input contacts. When the control is provided with a simultaneous 2-axis manual pulse generator, the machine can be moved simultaneously along the two axes.

The travel distance per step of the manual pulse generator is determined by the MP1, MP2 and MP4 (manual handle multiplication factor setting) input.

Notes :

- In an alarm state (ALM or IER output contact is closed), automatic mode handle offset motion is ineffective.
- When the interrupt input (STLK) contact is closed, manual handle mode motion is possible, but automatic mode handle offset motion is not possible.
- When executing automatic mode handle offset motion, parameter #6022, D_0 and D_1 for HOF SX (X-axis motion) and HOF SZ (Z-axis motion) must be set to 1.
- When parameter HOF SMV (#6022D₂) is set to 1, the automatic mode handle offset motion can be applied only to the time during the interpolation in the automatic operation modes.

19.2.5 MANUAL FEED AXIS DIRECTION SELECTION (+X, -X, +Z, -Z) INPUT

These inputs specify the motion direction when the control is in the manual jog mode or manual step feed mode.

Table 19.1 Motion Direction of Axis

+X	-X	+Z	-Z	Motion Direction of Axis
1	0	0	0	Puls direction of X-axis
0	1	0	0	Minus direction of X-axis
0	0	1	0	Puls direction of Z-axis
0	0	0	1	Minus direction of Z-axis

1: Closed, 0: Open

Under other input conditions, axis motion is impossible, and current axis motion is stopped after deceleration.

19.2.6 MANUAL HANDLE/STEP MULTIPLICATION FACTOR (MP1, MP2, MP4) INPUT

When the control is in the manual handle/manual step feed mode, the motion distance per step is determined by these input signals.

Table 19.2 Manual Handle/Step Multiplication Factor

MP1	MP2	MP4	Manual Step Feed	Manual Feed Handle
0	0	0	1 pulse/step	
1	0	0	10 pulses/step	
0	1	0	100 pulses/step	
1	1	0	1000 pulses/step	100 pulses/step
1 or 0		1	10,000 pulses/step	100 pulses/step

1: Closed, 0: Open

Note :

Only when manual handle multiplication factor is 100 pulses/step, the control can be used by any multiplication. The multiplication factor should be set parameter #6223.

19.2.7 FEED OVERRIDE/MANUAL JOGGING SPEED SELECTION (FV1, FV2, FV4, FV8, FV16) INPUT, AND FEED OVERRIDE CANCEL (OVC) INPUT

- (1) These input signals are for specifying override speeds between 0 and 200% at 10% intervals on the programmed speeds. In the manual jog mode, these inputs determine the manual jog feed rates.

Table 19.3

FV1	FV2	FV4	FV8	FV16	Feedrate Override (Automatic Operation Mode)	Manual Jog Feedrate (Manual Operation Mode) Setting
0	0	0	0	0	0%	#6233
1	0	0	0	0	10%	#6234
0	1	0	0	0	20%	#6235
1	1	0	0	0	30%	#6236
0	0	1	0	0	40%	#6237
1	0	1	0	0	50%	#6238
0	1	1	0	0	60%	#6239
1	1	1	0	0	70%	#6240
0	0	0	1	0	80%	#6241
1	0	0	1	0	90%	#6242
0	1	0	1	0	100%	#6243
1	1	0	1	0	110%	#6244
0	0	1	1	0	120%	#6245
1	0	1	1	0	130%	#6246
0	1	1	1	0	140%	#6247
1	1	1	1	0	150%	#6248
0	0	0	0	1	160%	#6249
1	0	0	0	1	170%	#6250
0	1	0	0	1	180%	#6251
1	1	0	0	1	190%	#6252
0	0	1	0	1	200%	#6253
1	0	1	0	1	0%	#6254
0	1	1	0	1		#6255
1	1	1	0	1		#6256
0	0	0	1	1		#6257
1	0	0	1	1		#6258
0	1	0	1	1		#6259
1	1	0	1	1		#6260
0	0	1	1	1		#6261
1	0	1	1	1		#6262
0	1	1	1	1		#6263
1	1	1	1	1		#6264

1: Closed, 0: Open

Note : for Table 19.3:

- 1. When parameter FOVAB (#6020D_s) is set to 1, inputs FV1, FV2, FV4, FV8, and FV16 become effective when the contacts are open, and 0 and 1 in the table for the input state and feed override manual jog speeds are reversed.
- 2. The manual jog feed rates can be used as the feed rates for part program by run execution in the automatic operation modes. For details, refer to 19.2.14 Dry Run (DRN) Input.
- 3. For the thread-cutting in part program execution in the automatic operation modes, override is possible only at 100%.

(2) Feed Override Cancel (OVC) Input

This is the input for fixing the feedrate override at 100%. When the OVC input contact is closed, the feed rate in part program execution in the automatic operation modes is locked at the programmed value, irrespective of the override input conditions.

19.2.8 RAPID FEEDRATE OVERRIDE (ROV1, ROV2, ROV4) INPUT

These inputs are for overriding the rapid feed rates, i. e., the positioning speed when executing programs in the automatic operation modes, and the motion speed in the manual jog mode when the RT input contact is closed.

Table 19.4

Input State		Rapid Feedrate	
ROV1	ROV2	X-axis	Z-axis
1	1	#6280 Setting speed	#6281 Setting speed
0	1	#6280 Setting speed × 1/2	#6281 Setting speed × 1/2
1	0	#6280 Setting speed × 1/4	#6281 Setting speed × 1/4
0	0	F ₀ (#6231 Setting speed)	

1: Closed, 0: Open

Rapid feedrate override is changed from 4 steps to 6 steps by parameter #6018 D2=1.

Table 19.5

Input State			Rapid Feedrate	
ROV1	ROV2	ROV4	X-axis	Z-axis
1	0	1	100%	100%
0	0	1	50%	50%
1	1	0	25%	25%
0	1	0	10%	10%
1	0	0	5%	5%
0	0	0	F ₀ (#6231 Setting speed)	

1: Closed, 0: Open

19.2.9 REFERENCE POINT RETURN CONTROL I/O SIGNALS (ZNR, *DCX, *DCZ)

These are input and output signals for bringing the machine to the machine reference point upon the energization of the control.

(1) Grid Method

Reference point is determined by the origin pulse (1 pulse/revolution) of the position detector. After turning on the power supply, when the manual jog mode is turned on, and the manual reference point return input contact ZRN is closed, the direction of axis motion set by parameter ZRNDRX, ZRNDRZ (#6010 D0, D1) will result in the reference point return motion as shown below. (The same applies to the execution of G28 in the automatic operation modes.)

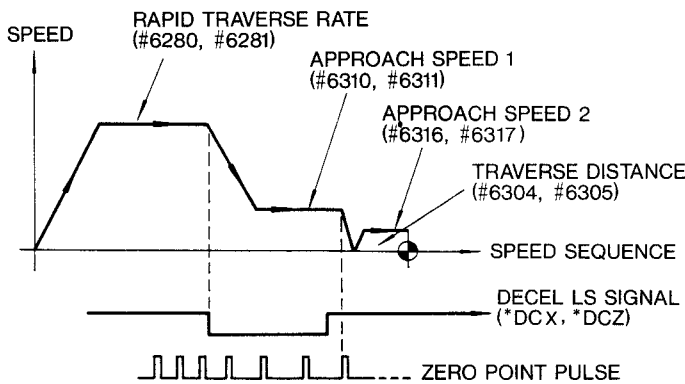

Fig 19.4

When the machine is returned to the reference point once, the return motion, thereafter will be in the positioning motion to the determined reference point.

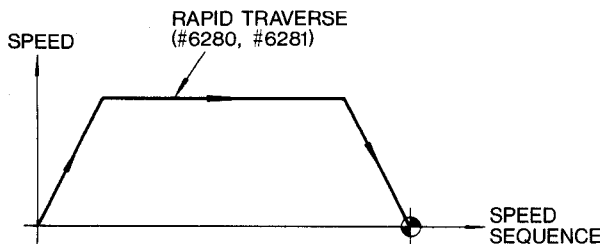

Fig. 19.5 Reference Point Return Motion after First Power ON

However, when parameters MZRNHS, AZRNHS (#6010 D4, D5) are set to 1, the same reference point return motion is obtained also for the 2nd time onward.

(2) X and Z Reference Points (ZPX, ZPZ) Output

While the machine is remaining at the reference point after the reference point return motion or positioning to the reference point, the ZPX and ZPZ output contacts are closed. If the actual position is not within ± 3 pulses from the reference point due to the use of metric input in the inch output system or vice versa, the ZPX and ZPZ output contacts are not closed.

(3) 2nd Reference Point (2ZPX, 2ZPZ) Output

When the machine has been positioned to the 2nd reference point by the execution of the part program command G30 in the automatic operation mode, the 2ZPX, and 2ZPZ output relays are closed, and remain closed as long as the machine remains at this point. The 2nd reference point is defined by the distance from the reference point as set by parameters XZP2L, ZPZ2L (#6612, #6613).

19.2.10 MANUAL ABSOLUTE ON/OFF (ABS) INPUT

During the execution of part programs in the automatic operation mode, the control stores the command values in an internal command value register (command values are displayed on the 1st CRT area), and the displacement distance between the stored value and the coordinate value in the part program.

Since the control must also control the current position, it controls the current values in the absolute coordinate system (to be displayed in the 2nd CRT area. The coordinate system is defined by a coordinate system setting command.)

This input is for determining whether the current value in the absolute coordinate system is transferred to the command value register or not at the start of the execution of the respective blocks of part programs in the automatic mode.

- When ABS input relay is open: Does not transfer.
- When ABS input relay is closed: To be transferred, except when circular interpolation is used.

The motion path after a manual control intervention in the automatic operation mode is changed as follows by an ABS input.

(1) When ABS Input Relay is Open

The motion path after an intervention by manual axial motion, is the one shifted parallel from the original path by the distance covered by the manual motion.

```
G01 Z20.000 FΔΔ;
X20.000 Z30.000 ← ①
X10.000 Z40.000
```

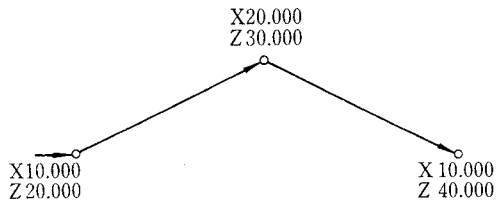

Fig. 19.6

① When the machine is manually moved during a block.

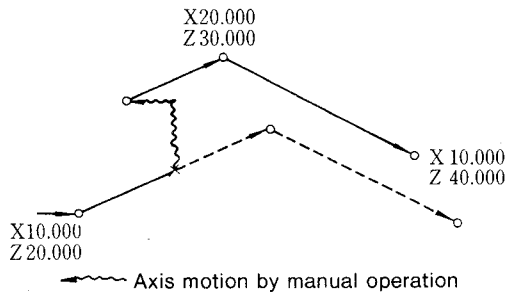

Fig. 19.7

(2) When ABS Input Relay is Closed.

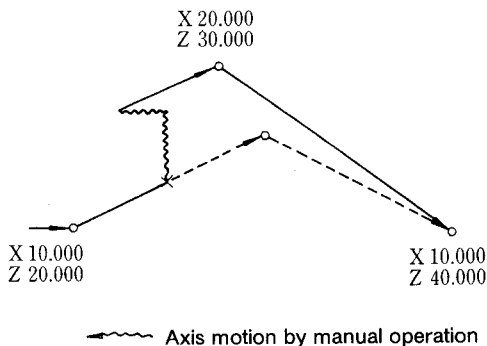

Fig. 19.8

(3) Supplementary Description

In the following cases, the control transfers current value in the absolute coordinate system (coordinate system displayed in the CRT current value 2nd area, or the one determined by coordinate system setting instructions) to the command value register unconditionally.

- RESET operation: MDI panel RESET key-on or external reset (ERS) input contact closed
 - End of program: Program reset through end of program (EOP) input contact closing by M02, M30 execution
 - Automatic return to reference point: Execution of G28 command
- After transferring the current value in the absolute coordinate system to the command value register, manual axial movement even when the ABS input contact is closed.

When the block ① is searched again by the RESET operation after axial motions by manual operation, the following motion takes place.

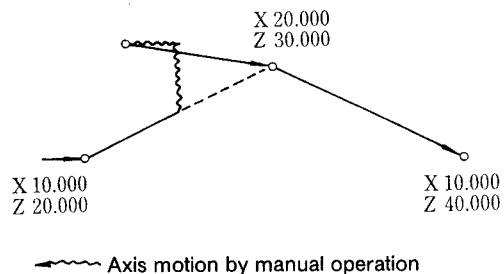

Fig. 18.9

19.2.11 SINGLE BLOCK (SBK) INPUT

This input is for executing part programs one block at a time in the automatic operation mode. With the control in the automatic operation mode, and the SBK input contact closed, when an automatic operation cycle is started, only one block of the part program is executed, and the machine stops. When the SBK input contact is closed during the execution of a part program, the control stops the machine after the execution of the current block.

For details of the use of single block during the execution of multiple cycles, user-macro programs, refer to "YASNAC J50L Instruction Manual (TOE-C843-12.20)."

19.2.12 OPTIONAL BLOCK DELETE (BDT, BDT2-BDT9) INPUT

This input is for determining whether data between “/” and “EOB” in a part program is executed or neglected when the part program contains “/.”

Table 19.6

	Neglected Data between
BDT INPUT CLOSED	“/” or “/1” and “EOB” (End of block)
BDT 2 INPUT CLOSED	“/2” and “EOB”
BDT 3 INPUT CLOSED	“/3” and “EOB”
BDT 4 INPUT CLOSED	“/4” and “EOB”
BDT 5 INPUT CLOSED	“/5” and “EOB”
BDT 6 INPUT CLOSED	“/6” and “EOB”
BDT 7 INPUT CLOSED	“/7” and “EOB”
BDT 8 INPUT CLOSED	“/8” and “EOB”
BDT 9 INPUT CLOSED	“/9” and “EOB”

Notes :

1. Data can be neglected only when part programs are executed. When storing or processing part programs, this input has no effect.
2. Whether data may be neglected or not depends on the state of the optional block delete input relay when the block containing “/” in a part program is stored in the buffer. Therefore, when controlling the optional block delete input relay by an external circuit with the use of the auxiliary function, take care to set the input state before the block containing “/” is stored in the buffer.

19.2.13 MACHINE LOCK (MLK) AND DISPLAY LOCK (DLK) INPUT

(1) Machine Lock (MLK) Input

This is the input for preventing the outputting of control output pulses to the servo unit. While the MLK input contact is closed, even when the logic circuit distributes pulses in the automatic and manual operation modes, the machine does not move. As the logic circuits distribute pulses, the current value display changes with the instructions. If the MLK contact is closed or opened during the automatic operation of the control, the operation is not influenced until the start of the next block, and during manual operation, until the end of the current motion.

(2) Display Lock (DLK) Input

This input is for preventing the output pulses of the control from being displayed on the external current value display. While the DLK input contact is closed, even when the machine is controlled automatically or manually, the external current value display (DRT. POS 1st display area “EXTERNAL,” and external 2-axes current value display) does not change.

19.2.14 DRY RUN (DRN) INPUT

This input is for changing the feedrates of the tools during the execution of part programs in the automatic mode to the rates selected by the manual continuous feed selection inputs (FV1, 2, 4, 8 and 16).

While the DRN input contact is closed, the feedrates during the execution of part programs in the automatic mode are changed from the programmed ones to the ones selected by the manual continuous feed selection inputs.

While the DRN input contact is closed, the feedrates in part program execution in the automatic mode are the ones specified by the manual continuous feed selection input signals, instead of the programmed one. (However, for thread cutting, programmed feedrates remain effective.)

When the DRN input contact is closed or opened during the automatic operation of the control, the following change takes place.

During mm/rev feeding: No change of feedrate for the current block.

During mm/min feeding: Feedrate changes even during the current block.

Notes :

1. When parameter RPDDRN (#6006 D2) is set to 1, while the DRN input contact is closed, the feedrate in positioning command is changed to a manual continuous feedrate.
2. When parameter SCRDRN (#6019 D5) is set to 1, while the DRN input contact is closed, the feedrate is changed to a manual continuous feedrate.

19.2.15 CURRENT VALUE STORING (PST) INPUT

This input is for storing current values in the control.

When the PST input contact is closed, the control stores current values (CRT screen POS display 1st area EXTERNAL) into the internal memory, and the LED incorporated in the OFS key in the MDI FUNCTION area flickers.

Then, it performs the following calculation on the offsets written by MDI, and stores the result in the offset memory.

$$\boxed{\text{Values to be written in offset memory}} = \boxed{\text{Input value}} - \boxed{\text{Current value stored in control}}$$

Resetting operation (depressing RESET key on MDI panel, or closing external reset input contact) cancels the current value storing mode and stops the flickering of the LED.

For the details of the usage of the PST input, refer to 5.2.3 Measured Workpiece Value Direct Input in YASNAC J50L Instruction Manual (TOE-C843-12.20).

19.2.16 PROGRAM RESTART (PRST) INPUT

This input is used when a part program is to be started again after interruption. Close the PRST input contact, turn of the memory mode, and search the sequence No. of program restart by the NC operator's panel. The M, S, T codes present between the leading end of the program and the searched sequence No. are displayed on the CRT.

For the details of the usage of the PST input, refer to "5.2.6 Program Restart" in YASNAC J50L Instruction Manual (TOE-C843-12.20).

19.2.17 EDIT LOCK (INHEDT)

This is the input for preventing the change of the contents of the stored part program. While the INHEDT input contact is closed, the following operations, among the ones in the program edit mode, are prohibited.

- Storing part programs by the MEM DATA "IN" key
- The change, addition or deletion of part programs in the memory with the EDIT "ALT," "INS" and "ERS" keys.

19.2.18 AUXILIARY FUNCTION LOCK (AFL) INPUT

This is the input for omitting the M, S, T function in executing part program in the automatic operation mode.

While the AFL input contact is closed, the control disregards M, S, T instructions of programs when executing part programs.

However, M code decoded outputs (M00R, M01R, M02R, M30R) are outputted.

When the AFL input contact is closed or opened during the execution of part programs, the change become effective from the block subsequent to the current block.

NOTE

With S4-digit instructions analog outputs are output in accordance with the instructions, even while the AFL input contact is closed.

19.2.19 SETUP POINT RETURN (SRN) INPUT

This is the input for positioning the machine at the setup point by manual jogging.

While the SRN input contact is closed, manual jog motion stops as the machine arrives at the setup point. When the machine is at the setup point, manual jogging is impossible unless the SRN input contact is opened.

19.2.20 INTERRUPTION POINT RETURN (CPRN) INPUT

This is the input for positioning the machine at the interruption point by manual jogging after the control was switched over from the automatic operation mode to the manual operation mode, and subsequently moved away under manual control.

While the CPRN input contact is closed, manual jogging motion stops after arriving at the interruption point. When the machine is at the interruption point, manual jogging is impossible unless the CPRN input contact is opened.

19.2.21 OVERTRAVEL (*+LX, *-LX, *+LZ, *-LZ) INPUTS

These input signals are for signifying the arrival of the machine slides at their respective stroke ends. When there overtravel input contacts are opened, the machine slides stop motion, as shown in Table 19.7, and close the alarm (ALM) output contact and, at the same time, display alarm on the CRT.

Table 19.7

	Manual Operation Mode	Automatic Operation Mode
*+LX Input Opened	Motion stop in +X direction	Motion stop of all axes
*-LX Input Opened	Motion stop in -X direction	
*+LZ Input Opened	Motion stop in +Zdirection	
*-LZ Input Opened	Motion stop in -Z direction	

When an overtravel input contact is opened, move the machine in the reverse direction in the manual operation mode (manual jogging or manual pulse generator) to close the contact, and then make the alarm output and display.

NOTE

Even when the overtravel input contacts are opened, the M code reading output (MF, S code reading output SF, and the T code reading output TF) are not turned off. If the motion by M codes, S codes of T codes must be stopped by overtraveling inputs, interlock the motion with external sequence.

19.2.22 MACHINE-READY (MRD) INPUT

This input informs that the external heavy-current circuit is ready. When MRD input is closed after closing of Servo Power Input/Output (SVMX) from the power-on/off unit of the control after the power is turned on, the control is ready and "RDY" is displayed on the CRT screen.

When MRD input is opened with the control being ready, the control is put in the alarm state alarm code "280" is displayed, thereby stopping the operation.

For the turning of power sequence, refer to "10 CONNECTION OF INPUT SEQUENCE"

19.2.23 EMERGENCY STOP ON (*ESPS) OUTPUT

When Emergency-Stop Input (*TESP) is opened, *ESPS output is opened.

19.2.24 EXTERNAL RESET (ERS) INPUT AND RESET ON (RST1,2) OUTPUT

ERS is the input to reset the control. When ERS input is closed, the control stops all of its operations, closing Reset On outputs RST1 and RST2 for one second. The output signals are opened except for the following.

Table 19.8

Output Signals	Output at ERS Input Closed
AUT/MAN ZPX/ZPZ ZYPX/ZYPZ *ESPS PO1-2 SO1-2	Previous conditions kept.
RST	Output contact is closed for one second while ERST input contact is closed or is opened.
ALM	Contact kept closed unless alarm causing factor is removed.
S11-S28 T11-T28 DS1-2 SINVA RO1-2 SDO0-15	Previous conditions kept.
TLCH1-2	Contact closed if any of selected, group of tools reaches end of life.
UO0-15	Previous conditions kept.

Note :

When ERS input is closed, the control is put in the label skip state. However, memory is rewound, while the tape is not.

19.2.25 INTERLOCK (STLK) INPUT

This input stops the spindle travel in the automatic operation mode. When "STLK" input is closed during the spindle travel in the automatic operation mode, only the spindle travel is stopped with the automatic operation being activated ("STL" output is in the closed state). When "STLK" input is opened again, the spindle travel is resumed.

"STLK" input does not affect the M, S, and T commands in both manual and automatic operation modes.

19.2.26 AMARM (ALM) AND INPUT ERROR (IER) OUTPUTS AND EXTERNAL ERROR DETECT (ERR0,1) INPUTS

(1) Alarm (ALM) and Input Error (IER) Outputs

These outputs inform that the control is in the alarm state.

IER: This output is closed on detection of an alarm caused by the information from the part program or the input device.

(Alarm codes "010" through "129.")

ALM: This output is closed on detection of any alarm other than the above. (However, the alarm for the fault of the logic circuitry in the control is not included.)

These outputs are opened again when the cause of the detected alarm has been removed and RESET operation is performed.

(2) External Error Detect (ERR0, ERR1) Inputs

These inputs put the control in the alarm state from the outside.

ERR0: When this input is closed, the control displays alarm code "180" and is put in the alarm state. If this input is closed during the execution of the part program in the automatic operation mode, the execution is stopped on completion of the block being executed.

ERR1: When this input is closed, the control displays alarm code "400" and is put in the alarm state. If this input is closed during the execution of the part program in the automatic operation mode, the tool travel is immediately slowed down and stopped.

19.2.27 RAPID THREADING PULL-OUT (CDZ) INPUT AND ERROR DETECT-ON (SMZ) INPUT

(1) Rapid Threading Pull-out (CDZ) Input

This input determines whether rapid threading pull-out is performed or not in the execution of G92 (thread cutting cycle) or G76 (composite thread cutting cycle). When CDZ input is closed, the rapid threading pull-out is performed; when this input is open, it is not performed.

The control determines by the CDZ input whether rapid threading pull-out is performed or not at the start of a thread cutting cycle. To open/close CDZ input by such a command as M, add the delay time of the input circuit processing and set the state of CDZ input to the start of thread cutting cycle.

(2) Error Detect ON (SMZ) Input

This input determines whether “Error Detect On” condition is added to the end conditions for the feed in the automatic operation mode.

Error Detect On:

Due to the servo system delay, during travelling, the position detected by the position detector follows, the position designated by the logic circuit with a delay. When the designated position and the detected position are found under the values set in parameters XPSET and ZPSET (#6056 and #6057), it is called in the “Error Detect On” state.

When SMZ input is closed, “Error Detect On” condition is added to the feed end conditions in the automatic operation mode.

When this input is open, this condition is not added.

SNZ input does not affect any positioning commands. (With each positioning command except G06 (Error Detect Off Positioning), “Error Detect On” condition is added to the end conditions.)

19.2.28 X-AXIS MIRROR IMAGE (MIX) INPUT

This input inverts the X-axis travelling direction in the automatic operation mode. When an automatic activation is performed with MIX input closed, the X-axis travelling direction by the part program is made opposite to the specified direction. When MIX input is closed then opened during the execution of the part program, it is made valid for the commands after the satisfaction of the following two conditions:

- (1) Compensation cancelled.
- (2) Out of automatic operation.

MIX input does not affect the X-axis travel in the manual operation mode.

19.2.29 M, S, AND T CODES (M11 THROUGH M38, S11 THROUGH S28, T11 THROUGH T28, MF, SF, TF, FIN) INPUTS/OUTPUTS

(1) M, S, and T Codes Output and M, S, and T Code Reading Outputs

Table 19.9

M code output	M11, M12, M14, M18, M21, M22, M24, M28, M31, M32, M34, M38
S code output	S11, S12, S14, S18, S21, S22, S24, S28
T code output	T11, T12, T14, T18, T21, T22, T24, T28
M code reading output	MF
S code reading output	SF
T code reading output	TF

These are outputs for the M, S, and T commands specified by the part program at its execution in the automatic operation mode. If any of M, S, and T commands is found at the execution of the part program in the automatic operation mode, the control outputs it in a BCD code according to the value that follows the detected command (M=2 digits / 3 digits, S=2 digits, T=2 digits).

Then, after the elapse of the time set in parameter MSTF (#6220), the M, S, and T code reading outputs are closed.

NOTE

- 1. With the S4 digit command, analog output is provided, disabling the S code output and the S-code read output.
- 2. M commands (M90 through M109) for logic circuit processing: With the T commands (T ○○○△△ , T51 △△ through T80 △△ , T90 △△ , T□□90 through T□□95, and T□□99), the M/T code output and the M/T code reading output are not provided.

(2) M Decode (M00R, M01R, M02R, and, M30R) Output

When any of M commands “M00,” “M01,” “M02,” and “M30” is executed, the corresponding decoded output “M00R,” “M01R,” “M02R,” or “M30R” is outputted in addition to the M code output and the M code reading output.

NOTE

When an M command for decoded output and a move command are specified in the same block, the M code output is provided at the start of the block, while the decoded output is provided after completion of the move command.

(3) M, S, and T Functions Completion (FIN) Inputs

These inputs give the completion of M, S, and T commands to the control. When FIN input is closed while the M, S, and T code reading (MF, SF, and TF) outputs are closed, they are opened. If FIN input is opened again after making sure of their opening, the control assumes that the M, S, or T command has been completed, starting the operation of the next step.

NOTE

- 1. For the S4-digit command, FIN input need not be closed.
- 2. When FIN input is closed then opened, the M code output and the M decoded output are all opened, but the S code and T code outputs remain without change.

19.2.29 M, S, AND T CODES (M11 THROUGH M38, S11 THROUGH S28, T11 THROUGH T28, MF, SF, TF, FIN) INPUTS/OUTPUTS (Cont'd)

(4) Time Chart of M, S, and T Signals

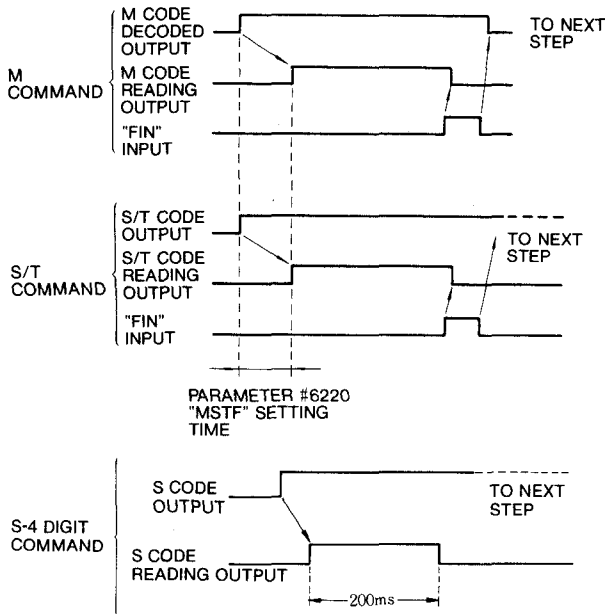

Note : Parameter #6011, D6=1

Fig. 19.10

If a move command and an M, S, or T command are specified in the same block, the move operation and the M, S, or T operation are executed simultaneously.

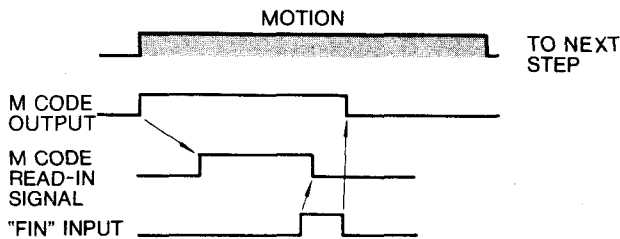

Fig. 19.11

19.2.30 POSITIONING COMPLETION (DEN 1,2) OUTPUTS

These outputs inform the completion of a move command when an M, S, or T command and the move command have been specified in the same block at the execution of a part program in the automatic operation mode.

The block in which an M, S, or T command and a move command are specified at the same time is executed if the M, S, or T command is not completed at the termination of the move command, positioning completion outputs DEN1 and DEN2 are closed.

When FIN input is closed then opened and the M, S, or T command is completed, the positioning completion outputs are opened.

19.2.31 TRAVEL ON (OP1,2) AND THREAD CUTTING ON (THC 1,2) OUTPUTS

(1) Travel ON (OP1, 2) Outputs

With these outputs, the control informs that the tool is traveling during the execution of a part program in the automatic operation mode. These outputs are closed in any of the following situations:

- During the execution of a move command.
- In the state in which a move command is discontinued by the interrupt (STLK) input or the FEEDHOLD (*SP) input.

(2) Thread Cutting ON (THC1, 2) Outputs

With these outputs, the control informs that thread cutting is being performed during the execution of part program in the automatic operation mode. These outputs are closed during thread cutting.

19.2.32 END-OF-PROGRAM (EOP) INPUT, REWIND (RWD) INPUT AND REWIND ON (RWDS1,2) OUTPUTS

(1) End-of-Program (EOP) and Rewind (RWD) Inputs

With these outputs, the controller determines what processing is to be performed at completion of an M02 or M30 command. The control performs the following processing, depending on the state of EOP and RWD inputs, when completion input FIN for an M02R or M30R commands is opened and then closed:

In general, EOP input is connected to M02R output and RWD input, to M30R output.

Table 19.10

EOP	RWD	Function
1	1	The control is at standby after rewinding part programs and resetting programs.
1	0	The control is at standby after resetting programs.
0	1	The control is at standby after rewinding part programs.
0	0	The control is at standby.

1: Closed, 0: Open

Notes :

1. Program reset provides the same effects as with depressing of RESET key on MDI panel (ERS) input. In the program reset, however, the NC memory rewind operation is not performed. For details of the reset operation by closing ERS input, refer to 19.2.24 "EXTERNAL RESET (ERS) INPUT AND RESET ON (RST 1, 2) OUTPUT."
2. When a program reset operation is performed, Reset On output RST is closed for one second.

(2) Rewind ON (REWDS1, 2) Outputs

With these outputs, the control informs that the part program is being rewound. If the part program is rewound by RWD input for an M02 or M30 command, RWDS1 and RWDS2 are closed during the rewinding operation.

NOTE

To use these outputs, set parameter RWDOUT (#6007 D4) to "1." Otherwise, they are not provided.

19.2.33 DISPLAY RESET (DRSX, DRSZ) INPUTS

These inputs set the external 2-axis current value display and the current value display on the operator's panel CRT to "0." When "DRSX" (X-axis display reset) or "DRSZ" (Z-axis display reset) is closed, "0" is set to the external 2-axis current value display and the current value display on the operator's panel CRT (the first screen "EXTERNAL").

19.2.34 EXTERNAL STORE, MATCH, AND OUTPUT (EIN, EVER, EOUT) INPUTS

These inputs are used to perform store, match, and output operations on the NC memory of the control from outside.

If these inputs are closed when the control is in the program edit mode and Edit Output On (EDTS) output is closed, the following operations take place:

EIN input is closed:

The part program is stored in the NC memory.

EVER input is closed:

The part program is matched against the NC memory.

EOUT is closed:

The contents of the NC memory are outputted.

While a store, match, or output operation is performed, the In-Edit (EDTS) output is closed.

NOTE

The I/O equipment for the store and match operations depends on setting IDVCE0, 1 and ODVCE0, 1 (#6003).

19.2.35 S4-DIGIT COMMANDS (DAS, SGS1, GR1 THROUGH GR4, SINV, AND SINVA) INPUTS/OUTPUTS

These signals are used to determine the speed of the spindle motor when the control is in the state of S Command 4-Digit Analog output.

GR1 through GR4 are used to enter into the control state of the gear range between the spindle and the spindle motor to determine the spindle motor speed by the spindle speed specified in the part program.

SINV input inverts the polarity of the analog output at the time of S Command 4-Digit Analog output.

While the polarity is inverted, SINVA signal is outputted.

(1) S4-digit Command Analog (GAS, SGS1) Output

Analog voltage (-10V to 0V to +10V) is outputted as follows by the spindle motor speed command and GR1 through GR4:

— — — — — ; The output when "GR1" input is closed. (Set the spindle motor maximum speed at gear range "GR1" to parameter GR1REV: #6271.)

— — — — — ; The output when "GR2" input is closed. (Set the spindle motor maximum speed at gear range "GR2" to parameter GR2REV: #6272.)

— — — — — ; The output when "GR3" input is closed. (Set the spindle motor maximum speed at gear range "GR3" to parameter GR3REV: #6273.)

— — — — — ; The output when "GR4" input is closed. (Set the spindle motor maximum speed at gear range "GR4" to parameter GR4REV: #6274.)

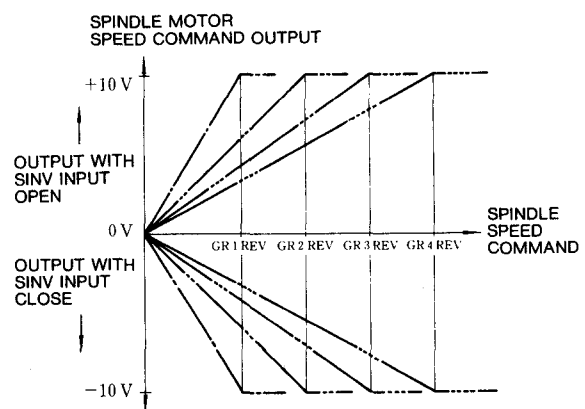

— — — — — : OUTPUT WITH "GR1" INPUT CLOSE
— — — — — : OUTPUT WITH "GR2" INPUT CLOSE
— — — — — : OUTPUT WITH "GR3" INPUT CLOSE
— — — — — : OUTPUT WITH "GR4" INPUT CLOSE

Fig. 19.12

19.2.35 S4-DIGT COMMANDS (DAS, SGS1, GR1 THROUGH GR4, SINV, AND SINVA) INPUTS/OUTPUTS (Cont'd)

(2) Time Chart of Analog Voltage Output, SINV Input, and SINVA Output for Spindle Motor Speed

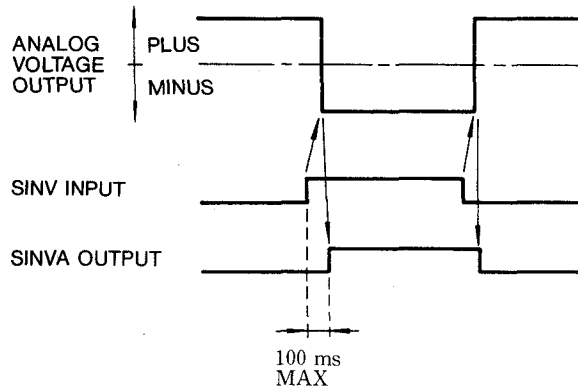

Fig. 19.13

(3) Spindle Maximum/Minimum Speed Clamp

The spindle maximum/minimum speed at each gear range may be set using the following parameters:

Table 19.11

Parameter	Function	No. in Fig below
MACGR1 (#6266)	Spindle maximum speed when "GR1" input is closed.	V
MACGR2 (#6267)	Spindle maximum speed when "GR2" input is closed.	VI
MACGR3 (#6268)	Spindle maximum speed when "GR3" input is closed.	VII
MACGR4 (#6269)	Spindle maximum speed when "GR4" input is closed.	VIII
MACGR1 (#6276)	Spindle maximum speed when "GR1" input is closed.	I
MACGR2 (#6277)	Spindle minimum speed when "GR2" input is closed.	II
MACGR3 (#6278)	Spindle minimum speed when "GR3" input is closed.	III
MACGR4 (#6279)	Spindle minimum speed when "GR4" input is closed.	IV

The following diagram shows an example of the S4-digit analog outputs when the spindle maximum/minimum speeds are clamped by these parameters:

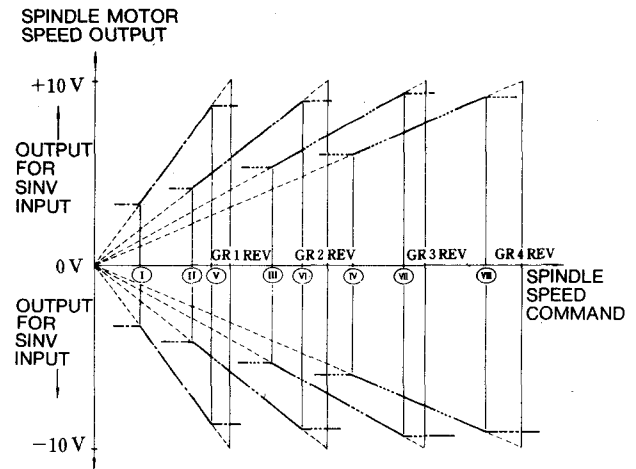

Fig. 19.14

Notes:

- The spindle motor speed command output is obtained from the following relation:
 $(\text{Spindle speed command}) \times (10V)$
 (Spindle gear range spindle maximum speed determined by GR1 through GR4 inputs: parameters #6271 through #6274)
- With the spindle motor speed command analog output, the polarity may be inverted by processing M03 (spindle forward rotation) or M04 (spindle reverse rotation) within the control by using parameter SDASGN1 or SDASGN2 (#6006 D6 or D7).

Table 19.12

SDASGN1 (#6006 D ₆)	SDASGN2 (#6006 D ₇)	M03 Output	M04 Output
0	0	+	+
1	0	-	-
0	1	+	-
1	1	-	+

When SINV input is closed, the above polarities are inverted.

- When spindle S Command Stop (SSTP) input is closed, a value other than those described earlier may be outputted for the spindle motor speed command. For details, refer to "SPINDLE S COMMAND STOP (SSTP) INPUT."
- When two or more of GR1 through GR4 inputs are closed or not closed, the control determines the gear ranges as follows:

Table 19.13

GR1 input	GR2 input	GR3 input	GR4 input	Gear Range
0	0	0	0	Gear range 1
1	1	0	0	
1	0	1	0	
0	1	1	0	Gear range 2
1	1	1	0	Gear range 1
1	0	0	1	
0	1	0	1	Gear range 2
1	1	0	1	Gear range 1
0	0	1	1	Gear range 3
1	0	1	1	Gear range 1
0	1	1	1	Gear range 2
1	1	1	1	Gear range 1

0: Input, 1: Input closed

Supplementary Explanation

Constant surface speed control and S4-digit command output:

When constant surface speed control (G96) is specified by the part program at its execution in the automatic operation mode, the output is varied every 100 ms according to the following relation during a cutting operation:

$$\frac{(\text{Surface speed by S command})}{(\text{X-axis current value}) \times (\pi)} \times (10V)$$

(Spindle gear range max. speed determined by GR1 to GR4 inputs)

Time Chart Example

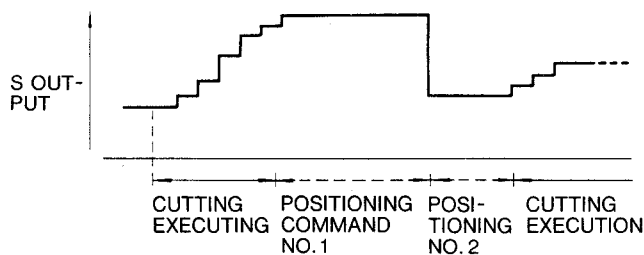

Fig. 19.15

Setting parameter POSG96 (#6020 D0) to "1" enables the control to perform the constant surface speed control also on the positioning command. (However, only the spindle speed obtained by the coordinate value of the positioning end point is outputted.)

19.2.36 SPINDLE S COMMAND "0" (SSTP), GEAR SHIFT ON (GRS) INPUT, AND SPINDLE CONSTANT SPEED (GSC) INPUT

These inputs are used to make the S4-digit command analog output provide the outputs other than the part program S command. When SSTP input is closed, the spindle motor speed command output based on the spindle speed specified in the part program is stopped.

If GRS input is closed in this state, the voltage to set to parameter GRSREV (#6270) is outputted.

If GSC input is closed, the spindle motor speed command voltage is outputted which corresponds to the spindle speed to be set to parameter GSCREV (#6275) by the spindle gear range input.

Table 19.14

SSTP Input	GRS Input	GSC Input	S4-digit Command Analog Voltage
0	0	0	Voltage corresponding to spindle speed commanded by NC program.
0	0	1	
0	1	0	
0	1	1	
1	0	0	0V
1	0	1	Voltage corresponding to parameter GSCREV.
1	1	0	Parameter GRSREV setting value.
1	1	1	0V

0: Contact open, 1: Contact closed

Notes :

1. It is possible to make the analog outputs for SSTP, GRS, and GSC inputs negative by the S4-digit analog output invert (SINV) input.
2. The period of time between the setting of SSTP, GRS, or GSC input and the catching-up of the analog voltage value is shorter than 100 ms.
3. Setting parameter SSTPAB (#6020 D₁) to 1 enable the control to provide "*SSTP" input.

19.2.37 SPINDLE SPEED REACHED (SAGR) INPUT

This input is used to inform, in the case of the S4-digit command, that the spindle speed has reached the specified value at the start of cutting at the execution of the part program in the automatic operation mode. At the start of cutting (when switching from a positioning command to a cutting command takes place), the control delays the time by the value specified in parameter SAGRRT (#6224), makes sure that SAGR input is closed, and starts cutting.

NOTE

1. To perform the above operation by SAGR input, set parameter SAGRCH (#6006 D4) to "1." If it is set to "0," SAGR input is ignored.
2. In G96 mode, SAGR input is checked every time the switching from a positioning command to a cutting command takes place. In G97 mode, SAGR input is checked at the switching only when the spindle speed is different between the positioning start and end times.

19.2.38 SPINDLE SPEED OVERRIDE (SPA, SPB, SPC, SPD AND SPE) INPUTS

These inputs are used, in the case of the S4-digit command, to override the S command in a range of 50% to 120% at the execution of the part program in the automatic operation mode.

19.2.38 SPINDLE SPEED OVERRIDE (SPA, SPB, SPC, SPD ANS SPE) INPUTS (Cont'd)

Table 19.15

SPA Input	SPB Input	SPC Input	Override to S Command
1	1	1	50%
0	1	1	60%
0	1	0	70%
1	1	0	80%
1	0	0	90%
0	0	0	100%
0	0	1	110%
1	0	1	120%

1: Closed, 0: Open

Override is specified to S command within 10% to 200% range by parameter #6018 D1.

Table 19.16

Input					Override to S Command
SPA	SPB	SPC	SPD	SPE	
0	0	0	1	0	10%
0	0	1	1	0	20%
0	1	1	1	0	30%
1	1	1	1	0	40%
1	1	1	0	0	50%
0	1	1	0	0	60%
0	1	0	0	0	70%
1	1	0	0	0	80%
1	0	0	0	0	90%
0	0	0	0	0	100%
0	0	1	0	0	110%
1	0	1	0	0	120%
1	0	1	1	0	130%
1	0	0	1	0	140%
1	1	0	1	0	150%
0	1	0	1	0	160%
0	1	0	1	1	170%
0	1	0	0	1	180%
0	0	0	0	1	190%
1	0	0	0	1	200%

1: Closed, 0: Open

19.2.39 S4-DIGIT COMMAND EXTERNAL OUTPUTS (SDO0 THROUGH SDO15) AND S4-DIGIT EXTERNAL INPUTS (SDI0 THROUGH SDI15)

These inputs and outputs are used, when the control is of S command 4-digit, to output the results of the operation by the S command in the part program to the outside and perform the actual S4-digit command analog output according to the inputs from the outside.

(1) S4-digit Command Analog Output

- Output of operation results to outside:
SDO0 through SDO15
- Inputs from outside to output analog voltage to DAS and SGS1:
SDI0 through SDI15

Note :

The input/output value is a signed binary 16-bit. The relationship with analog voltages is as follows: -32767 to 0 to +32768, -10V to 0 to +10V

NOTE

The primary purpose of this function is to control the S4-digit command by the sequencer built in the control. This function should not be used for other purposes unless especially required.

19.2.40 EXTERNAL WORK NUMBER SEARCH A (WN1, WN2, WN4, WN8, AND WN16) INPUTS

This is a function to select the program by the program number specified by external input from the part programs stored in the part program memory of the equipment.

- (1) To use this external work number search A, assign the program number as follows:

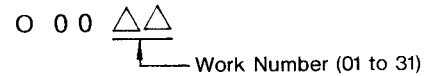

The work number search timing is as follows (provided that the external input (WN1 to WN16) is not "00"):

- a. At reset operation. (When RESET key is depressed, or the external reset input or EOP input is turned ON.)
 - b. When CYCLE START key is depressed in the memory mode and the label skip ON status.
- (2) The relationship between external inputs WN1 through WN16 and program numbers is as shown in Table 19.17.

Table 19.17

Program No.	Input Status				
	WN1	WN2	WN4	WN8	WN16
0001	1	0	0	0	0
0002	0	1	0	0	0
0003	1	1	0	0	0
0004	0	0	1	0	0
0005	1	0	1	0	0
0006	0	1	1	0	0
0007	1	1	1	0	0
0008	0	0	0	1	0
0009	1	0	0	1	0
0010	0	1	0	1	0
0011	1	1	0	1	0
0012	0	0	1	1	0
0013	1	0	1	1	0
0014	0	1	1	1	0
0015	1	1	1	1	0
0016	0	0	0	0	1
0017	1	0	0	0	1
0018	0	1	0	0	1
0019	1	1	0	0	1
0020	0	0	1	0	1
0021	1	0	1	0	1
0022	0	1	1	0	1
0023	1	1	1	0	1
0024	0	0	0	1	1
0025	1	0	0	1	1
0026	0	1	0	1	1
0027	1	1	0	1	1
0028	0	0	1	1	1
0029	1	0	1	1	1
0030	0	1	1	1	1
0031	1	1	1	1	1

1: Closed, 0: Open

Notes:

1. WN1 through WN16 inputs are disregarded at the start of a part program in other than memory and running modes. The start of a part program is when an automatic run is activated in the label skip state ("LSK" is being displayed on the CRT screen).
2. The program number selection by a reset operation is performed independently of the running mode.
3. When WN1 through WN16 inputs are all open, the program number selection is not performed.
4. If the part program memory of the control contains two or more part programs which have part program numbers 01 through 31 specified by WN1 through WN16, the program stored nearest the memory being is selected.
5. The program number for which this search function is valid are 00001 through 00031.
6. If the specified program number is not found after a search operation, error "134" is caused.
7. When this work number search A function is performed, FUNCTION is automatically changed to PROG.

19.2.41 TIME COUNT (EXTC) INPUT (OPTIONAL)

This input makes the control count the time. The control accumulates the time in which EXTC input is closed and displays the result in the bottom of "OPERATION TIME DISPLAY," which is on page 3 of "ALM" function on the operator's station CRT. (Operating time display "EXTERNAL" is optional.) The time display is reset by pressing "4" key then **ORG** key by the MDI. Until this reset operation is performed, the time display is retained after such an operation as power-on.

19.2.42 SPINDLE INDEXING FUNCTION (SID1-SID12) INPUT/OUTPUT

This input/output is used to perform the spindle indexing function which stops the spindle at the desired position by controlling the S4-digit analog output by the pulse from the spindle pulse generator.

(1) Input Signals

· SID 1 through SID 12:

Binary 12-bit (0 to 4095) input signals to specify the spindle stop position. Each signal corresponds to the pulse (4096 pulses/rev) from the spindle pulse generator. Usually, the stop position corresponds to the number of pulses entered by SID1 to SID12 from C-phase pulse (1 pulse/rev) of the spindle pulse generator.

Note: Use of parameter SIDREF (#6342) enables the control to shift the stop position by the number of pulses set from C-phase pulse to this parameter.

· SIDX:

The input signal to request the control for a spindle indexing operation. If this input is closed while the spindle is rotating, the speed command to perform indexing is output and the spindle indexing operation is started.

After the completion of the indexing operation, the spindle speed command analog output remains a spindle positioning command unless this input is turned off. Thereby making the control continue the indexing operation.

· SIDXI and SIDXINC:

SIDXI (spindle indexing restart input) and SIDXINC (spindle stop position designate incremental input) are the inputs for the repetitive spindle indexing sequence. For details, refer to (6), "Spindle Indexing Extension Function Input."

(2) Output Signals

· SIDXO:

This output goes on when the control is performing a spindle indexing operation (during the output of creep speed command or spindle positioning command).

19.2.42 SPINDLE INDEXING FUNCTION (SID1-SID12) INPUT/OUTPUT (Cont'd)

SIDXA:

This signal indicates the completion of a spindle indexing operation. It is on while the spindle position is in the range between the position set in parameter SPSET (#6058) and the position designated by SID1 to SID12.

(3) SPINDLE INDEX TIME CHART

- Spindle index by M-code at spindle stop (Spindle positioning is released after spindle index is completed.) See Fig. 19.16.
- Spindle index by m code at spindle forward operation (Spindle positioning is continued until next spindle speed command after spindle index is completed.) See Fig. 19.17.

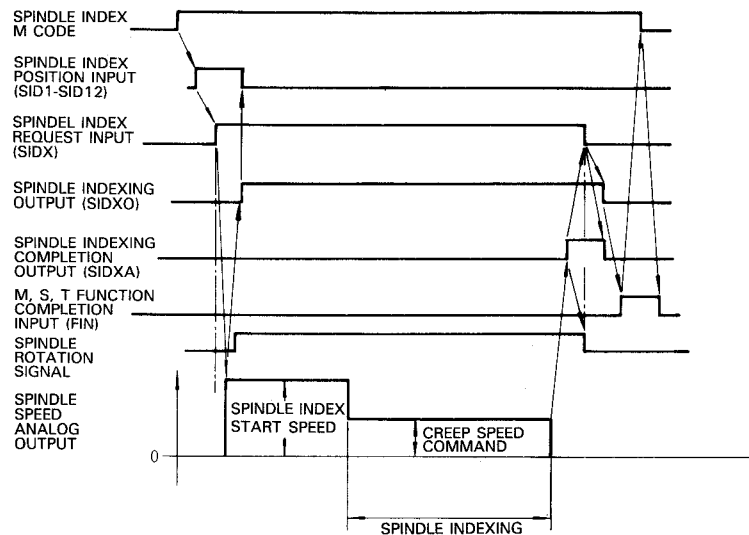

Fig. 19.16

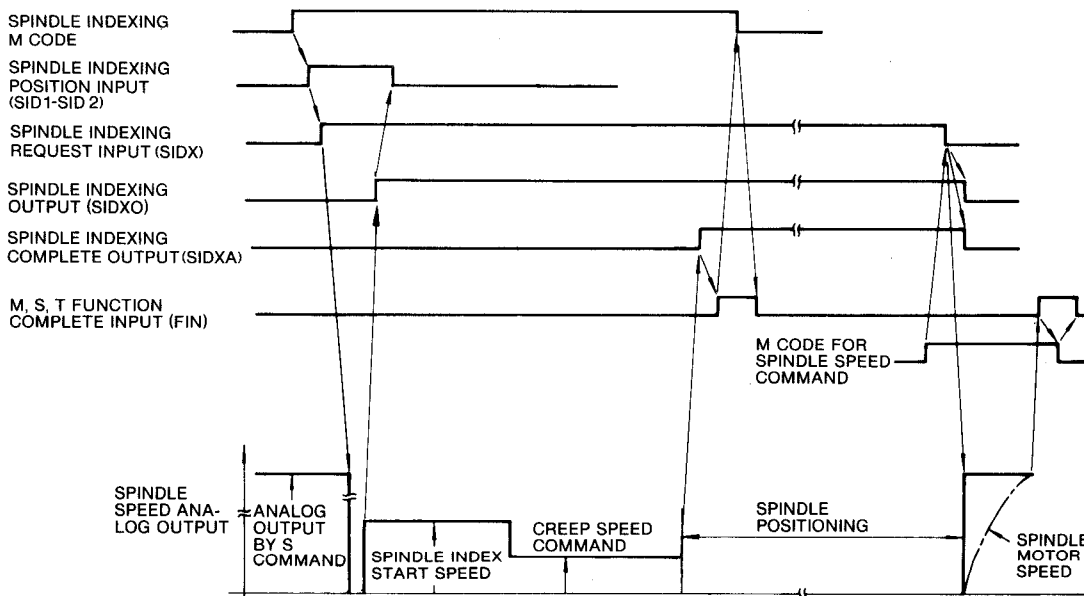

Fig. 19.17

(4) Parameters for Spindle Indexing and Detailed Spindle Indexing

Table 19.18

No.	Detailed Function of Spindle Indexing	Setting
#6058 (SPSET)	Pulse width of index completion output signal.	1=1 pulse
#6064 (BSS)	Bits setting for output saturation	Refer to parameter table.
#6076 (SSVER)	Servo alarm area setting for spindle drive	Refer to parameter table.
#6085 (SIDSER)	Timer setting to confirm the spindle stop	1=8 ms
#6342 (SIDREF)	Spindle index reference point setting	1=1 pulse
#6343 (SIDRV1)	Spindle index speed command	1=500 pps
#6344 (SIDCRP)	Spindle index creep speed command	1=500 pps
#6227 (KPS)	Position loop gain	Set 1024.

Note : 1 pulse = $0.088^\circ \left(\frac{360^\circ}{4096 \text{ pulses}} \right)$

(5) Display of Spindle Indexing Function

When the control contains the spindle indexing option, the following display is made under heading SPINDLE COUNTER on page 8 of the POSITION display on CRT screen:

- During a spindle indexing operation (SIDXO output is on), the number of pulses from the spindle pulse generator is displayed.

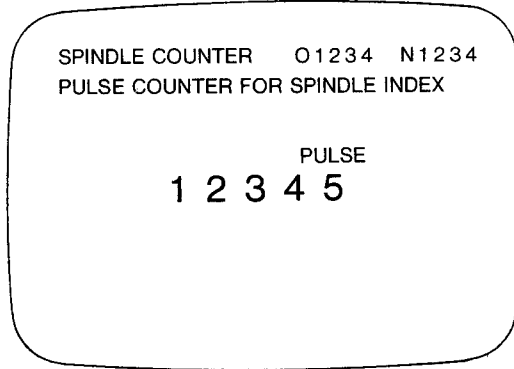

- When a spindle indexing operation is not performed (SIDXO output is off), the spindle speed (obtained by converting the number of pulses from the spindle pulse generator) is displayed.

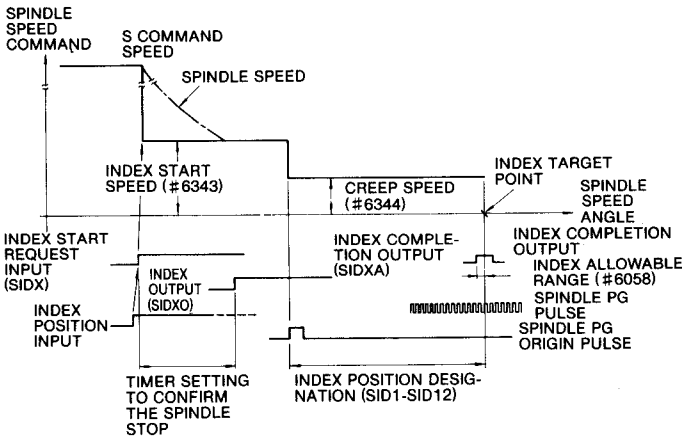
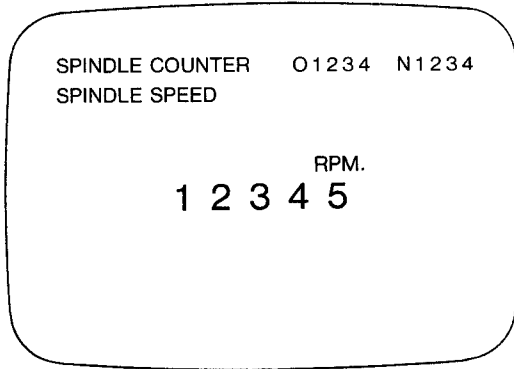

Fig. 19.18 Detailed Spindle Indexing

19.2.42 SPINDLE INDEXING FUNCTION (SID1-SID12) INPUT/OUTPUT (Cont'd)

(6) Spindle Indexing Extension Function Input

The control provides the following two inputs to process various spindle indexing sequence made available by application of the spindle indexing function described previously.

· SIDXI:

Spindle indexing restart input. If this input is closed with Spindle Indexing On (SIDXO) output on, the control stops the spindle indexing operation and turns the SIDXO output off. While the indexing operation is discontinued, the spindle speed command analog output becomes the spindle indexing start speed command.

When this input is turned off in this state, the control restarts the spindle indexing operation.

· SIDXING:

Spindle indexing position incremental input. This input is used to designate an incremental position of the spindle indexing position input (SID1 to SID12) from its previously designated position.

The use of this input enables the control to rotate the spindle from the current indexing position to the next indexing position without a full rotation. However, this input is invalid when the spindle indexing operation is first made after rotating the spindle in non-indexing operation or when the spindle indexing operation is first made after the power-on operation.

· Example of Spindle Indexing Time Chart using Spindle Indexing Extension Input:

- (i) Restart the spindle index if spindle index is not completed, the specified time after spindle indexing (Fig. 19.19).

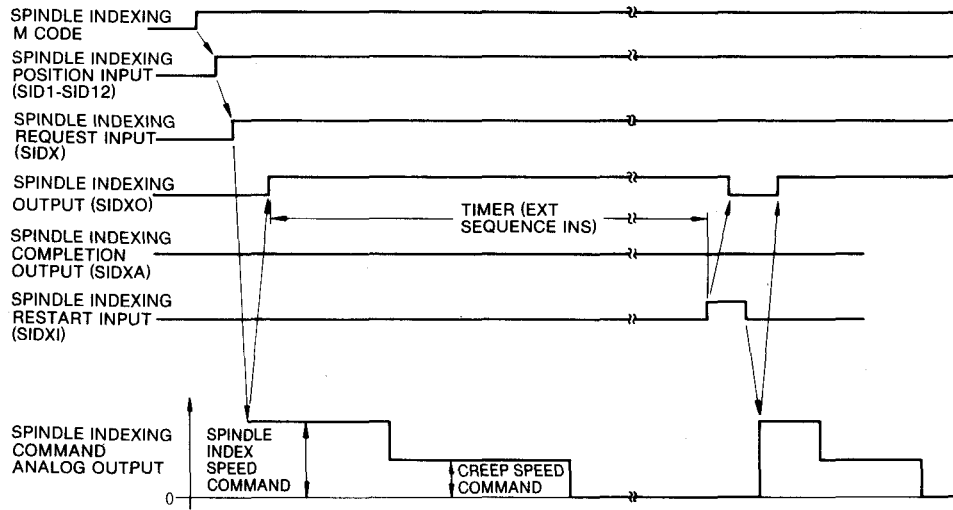

Fig. 19.19

(ii) Spindle indexing at a position 180° from the indexed position after spindle indexing and mechanical clamp and machining.
See Fig. 19.20.

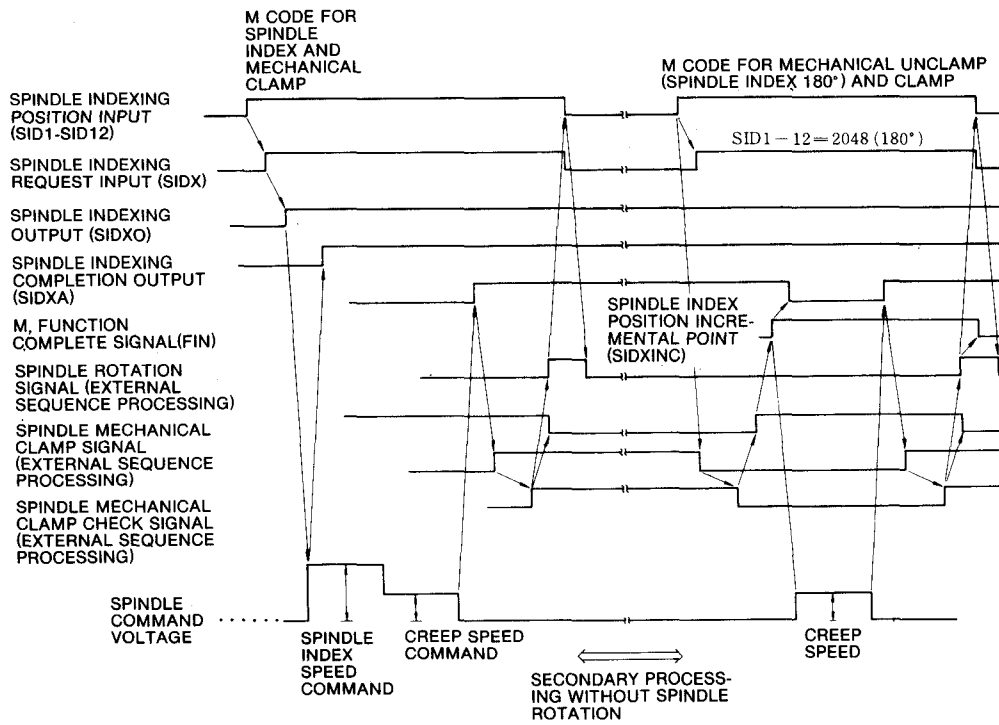

Fig. 19.20

Notes :

1. The spindle indexing function is available only when the control has the S command 4-digit analog output specification. The polarity of S 4-digit analog output should be externally determined by SINV input.
2. To make a spindle index from the spindle reverse rotating status, keep SINV input on while the spindle indexing request input (SIDX) is ON.
3. When an incremental spindle indexing operation is performed by turning SIDXINC input on with SINV input being on, the

4. A spindle indexing operation is not performed during interpolation pulse output.
5. Accumulated values of pulses by incremental command should be 10 pulses or less.
6. Spindle index is performed at the edge of C-phase pulse (1 pulse/rev) as a reference pulse. When C-phase pulse includes a pulse width as shown below, a spindle index position between the spindle forward and reverse rotating states is shifted by C-phase pulse width.

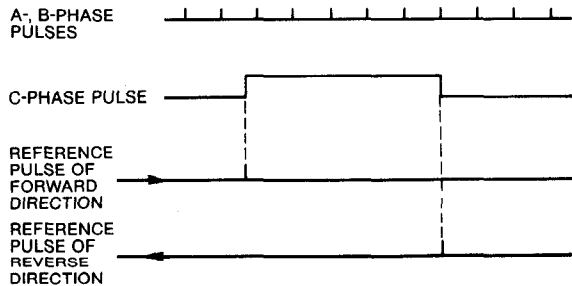

Fig. 19.21

19.2.43 STORED STROKE LIMIT 3 BY TOOL (TP1, TP2, TP4, TP8, TPS, TPSA) INPUTS/OUTPUTS

(1) Using the following input/output signals, this function sets a maximum of 15 types of stored stroke limit 3 as classified by tool. This is by the use of the external input:

- Tool number input — TP1, TP2, TP4, and TP8
- Area change input — TPS
- Area change complete output — TPSA

19.2.43 STORED STROKE LIMIT 3 BY TOOL (TP1, TP2, TP4, TP8, TPS, TPSA) INPUTS/OUTPUTS (Cont'd)

(2) At the power-ON, reset operation, or closing TPS input, the control selects the stored stroke limit area as follows according to TP input:

Table 19.19

Input Status				Parameter No. Setting Area
TP1	TP2	TP4	TP8	
1	0	0	0	#6508-#6511
0	1	0	0	#6512-#6515
1	1	0	0	#6516-#6519
0	0	1	0	#6520-#6523
1	0	1	0	#6224-#6527
0	1	1	0	#6528-#6531
1	1	1	0	#6532-#6535
0	0	0	1	#6536-#6539
1	0	0	1	#6540-#6543
0	1	0	1	#6544-#6547
1	1	0	1	#6548-#6551
0	0	1	1	#6552-#6555
1	0	1	1	#6556-#6559
0	1	1	1	#6560-#6563
1	1	1	1	#6564-#6567

1: Closed, 0: Open

(3) When the TPS input is closed, the control performs the area change, upon completion of which area change outputs TPSA1 and TPSA2 are closed.

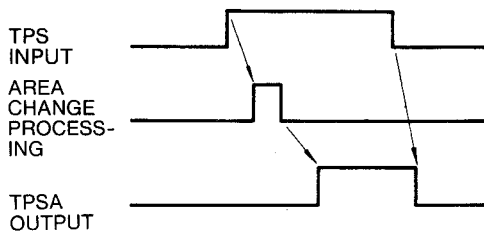

Fig. 19.22

If the TPS input is turned ON during the spindle shift in the auto or manual mode, the area change processing is not performed.

19.2.44 MACRO PROGRAM (UI0-UI15, UO0-UO15) INPUT/OUTPUT FUNCTION

These inputs/outputs are used as system variables in macro programs:

Table 19.20

System Variables	Input	System Variables	Input
#1000	UI 0	#1100	UO 0
#1001	UI 1	#1101	UO 1
#1002	UI 2	#1102	UO 2
#1003	UI 3	#1103	UO 3
#1004	UI 4	#1104	UO 4
#1005	UI 5	#1105	UO 5
#1006	UI 6	#1106	UO 6
#1007	UI 7	#1107	UO 7
#1008	UI 8	#1108	UO 8
#1009	UI 9	#1109	UO 9
#1010	UI 10	#1110	UO 10
#1011	UI 11	#1111	UO 11
#1012	UI 12	#1112	UO 12
#1013	UI 13	#1113	UO 13
#1014	UI 14	#1114	UO 14
#1015	UI 15	#1115	UO 15

19.2.45 EXTERNAL DATA INPUT (ED 0 THROUGH ED15, EDSA THROUGH EDSD, EDSA 0 THROUGH EDSA2, EDCL, EREND, ESEND) INPUTS/OUTPUTS

(1) These inputs/outputs are used to make the machine perform the following functions by external inputs.

- a. External work number search C
Search for a 4-digit program number.
- b. External tool compensation C
Modification of a 4-digit tool offset.
- c. External work coordinate system shift.
There are following input signals:
 - Data input — ED0 through ED15
 - Data designation — EDSA through EDSD
 - Axis designation — EDAS0 through EDAS2
 - Data request input — EDCL

The details of these input signals are as shown in Table 19.21.

Table 19.21

Item Signal Name	External Work No. Search	External Tool Compensation C
ED 0	Program No. No. of 1-digit (BCD code)	Compensation amount No. of 1-digit (BCD code)
ED 1		
ED 2		
ED 3		
ED 4	No. of 10-digit	No. of 10-digit
ED 5		
ED 6		
ED 7		
ED 8	No. of 100-digit	No. of 100-digit
ED 9		
ED 10		
ED 11		
ED 12	No. of 1000-digit	No. of 1000-digit (0 to 7)
ED 13		
ED 14		
ED 15		
EDSA	1	0
EDSB	0	1
EDSC	0	0
EDSD	0	0
EDAS 0	0 or 1	Axis designation 0: X, 1: Z
EDAS 1	0 or 1	0
EDAS 2	0 or 1	0: Incremental 1: Absolute
EDCL	Data read-in request	

1: Closed, 0: Open

There are following output signals:

- External data input complete — EREND
- External data search complete — ESEND

(2) External Work Number Search C

This function searches for the part program of a 4-digit program number designated by the input signal ED0 to ED15. The timing of signal transfer is as follows:

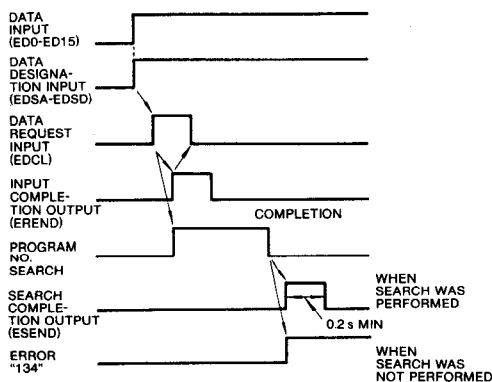

Fig. 19.23

- EDCL input is detected by the 8 ms scan.
- When EDCL goes ON, EREND is output within 8 ms, starting the search for the part program of the designated program number.
- If the desired program has been found, ESEND is output for more than 200 ms. However, this signal is not output when the Reset ON output is ON. It is output only when this output is turned OFF.
- If the desired program has not been found, error "134" is caused and ESEND is not outputted.

Note

This external work number search function is valid only in the memory mode and the label skip state. In any other conditions, EDCL input is invalid.

(3) External Tool Compensation C

This function adds or replaces the tool offset (0 to ±7.999 mm or 0 to ± 0.7999 in.) designated by input ED0 to ED15 to or with the currently designated tool offset memory value. When EDAS2 is "0," addition is made; when it is "1," replacement is made. The timing of signal transfer is as shown in Fig. 19.24.

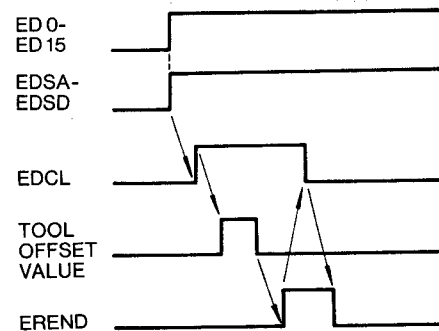

Fig. 19.24

- EDCL input is detected by the 8 ms scan.
- The tool offset number to be rewritten is the currently designated tool offset number. At the time of single block stop, the contents of the tool offset number of the terminated block are rewritten.

(4) External Work Coordinate System Shift

When the currently designated tool offset number is "00" in the external tool compensation C, this function adds or replaces the value (0 to ±7.999 mm or 0 to ±0.7999 in.) designated by input ED0 to ED15 to or with the work coordinate system memory value. When EDAS2 is "0," addition is made; when it is "1," replacement is made. The timing of signal transfer is the same as with the external tool compensation C.

19.2.45 EXTERNAL DATA INPUT (ED0 THROUGH ED15, EDSA THROUGH ESD, EDSA, 0 THROUGH EDSA2, EDCL, EREND, ESEND) INPUTS/OUTPUTS

Generally, the external tool compensation C and external work coordinate system shift functions must be activated by specifying a given M code in an appropriate location on the part program and turning on the data request input EDCL by that M code.

19.2.46 TOOL LIFE CONTROL (TLA1 THROUGH TLA16, TLTM, TLSKP, TLRST, TLCH1 AND TLCH2) INPUTS/OUTPUTS

The tool life control function enters the following into the control: the information on tool life (how long a tool is serviceable or how many workpieces a tool can cut), the tool numbers of tool groups of the same type and the compensation numbers to be used. This makes it possible, by simply specifying the T code for tool life control in the part program, for the control to control that T code according to the machining time and the number of workpieces entered.

Described here are only the signals associated with this function. For the program and other information, refer to "YASNAC J50L Instruction Manual (TOE-C843-12.20)."

This function uses the following inputs/outputs:

- Tool replacement completion tool group number inputs — TLA11, TLA12, TLA14, TLA18, and TLA21.
- Tool skip input — TLSKP
- Tool replacement request outputs — TLCH1 and TLCH2

It is also needed to make a registration of the following information through the program tape or CNC operator's panel MDI operation:

Table 19.22 Registration of Tool Groups

Setting Number	Registration
#8601	Tool group number of tool number "01." Setting 1 to 19.
to	to
#8650	Tool group number of tool number "50." Setting 1 to 19.

Table 19.23 Registration of Tool Life

Setting Number	Registration
#6161	Life of tool group "01."
to	to
#6169	Life of tool group "09." Machining count setting: 1=once.
#6170	Life of tool group "10."
to	to
#6179	Life of tool group "19." Machining count setting: 1=1min.

In addition, there are settings for registering compensation numbers and other information. Since they have no relation to the input/output, the explanation is omitted.

(1) Tool Replacement Complete Tool Group Number Inputs (TLA1, TLA2, TLA4, TLA8, AND TLA16) and Tool Replacement Complete Input (TLRST)

These inputs inform the control of the completion of tool replacement after the replacement of the tools of the group number whose life has terminated.

Set the tool group number of tool replacement complete to TLA1, TLA2, TLA4, TLA8, and TLA16 according to Table 19.24, and close TLRST input.

When the replacement of the tools of the group number whose life has terminated is all completed, tool replacement request outputs TLCH1 and TLCH2 are opened.

Table 19.24

Input					Tool Change Completion Group No.
TLA1	TLA2	TLA4	TLA8	TLA16	
1	0	0	0	0	01
0	1	0	0	0	02
1	1	0	0	0	03
0	0	1	0	0	04
1	0	1	0	0	05
0	1	1	0	0	06
1	1	1	0	0	07
0	0	0	1	0	08
1	0	0	1	0	09
0	1	0	1	0	10
1	1	0	1	0	11
0	0	1	1	0	12
1	0	1	1	0	13
0	1	1	1	0	14
1	1	1	1	0	15
0	0	0	0	1	16
1	0	0	0	1	17
0	1	0	0	1	18
1	1	0	0	1	19

1: Closed, 0: Open

(2) Tool Skip Input (TLSKP)

This input is used to replace registered tools before their lives terminate.

When TSKP input is closed in the automatic feedhold state (STL and SPL outputs are open), the processing that the service life of the currently used tool has terminated is performed within the controller. Then the new tool is specified by the following T command.

(3) Tool Replacement Request Outputs (TLCH)

When a program end or reset operation is performed after the termination of the service lives of all registered tools belonging to a tool group number, TLCH is closed.

When these outputs are closed, make sure of the tool group number which is being displayed on the CRT screen and replace the tools.

Note

When TLCH is closed, the automatic activation in the automatic operation mode is disabled.

19.2.47 SKIP INPUT

If SKIP input is closed during the execution of move command by G31 in the automatic operation mode, the control immediately stops the movement and stores the coordinate value where SKIP input changed from open to close. At this point, the block of G31 command is regarded to have been completed, and the following block is taken up.

The coordinate value of the skip position is stored in the following setting numbers:

#6568 --- X-axis coordinate value

#6569 --- Z-axis coordinate value

Note

1. The block of G31 command moves in the same way as G01. If parameter SKPFED (#6019 D4) is set to "1," the feed rate which is not specified in the part program but is set to parameter G31F (#6232) is provided.
2. If SKIP input is not closed after the completion of the block of G31 command, the following operation takes place:
 - When setting SKIPIN (#6004 D0) is set to "1," the following block is executed.
 - When setting SKIPIN (#6004 D0) is set to "0," the alarm state (alarm code "087") is generated.

19.2.48 COMBINED FIXED CYCLE CUTTING OVERRIDE (COV1, COV2, COV4, COV8, AND COV16) INPUTS

These inputs are used to override the cut depth of the stock removal cycle specified by G71 and G72. According to the state of these inputs, an override is applied to the cut depth specified in "D."

Table 19.25

Input					Override (%)
COV1	COV2	COV4	COV8	COV16	
0	0	0	0	0	0
1	0	0	0	0	10
0	1	0	0	0	20
1	1	0	0	0	30
0	0	1	0	0	40
1	0	1	0	0	50
0	1	1	0	0	60
1	1	1	0	0	70
0	0	0	1	0	80
1	0	0	1	0	90
0	1	0	1	0	100
1	1	0	1	0	110
0	0	1	1	0	120
1	0	1	1	0	130
0	1	1	1	0	140
1	1	1	0	0	150
0	0	0	0	1	160
1	0	0	0	1	170
0	1	0	0	1	180
1	1	0	0	1	190
0	0	1	0	1	200

1: Closed, 0: Open

19.2.49 SERVO POWER ON (SONPB) INPUT

- (1) If this input is closed when NC power is on (NCMX is ON), servo power turns on by power-on operation.
- (2) This input is equivalent to turning on servo power by the power ON pushbutton.
- (3) This input is effective if parameter #6030 $D_4=1$. If this parameter is selected, the power ON pushbutton cannot turn on servo power.

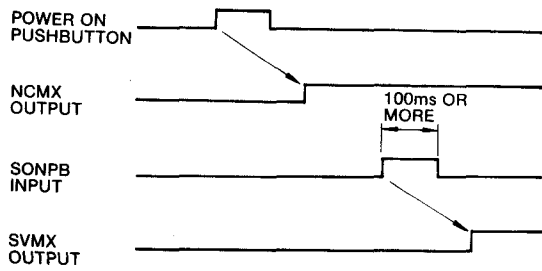

Fig. 19.25

19.2.50 HIGH-SPEED REWIND AND START (RWDH) INPUT

- (1) NC Performs high-speed rewinding by closing this input and by returning a completion signal (FIN) during execution of M30.
- (2) Automatic start is possible by selecting a parameter (#6023 $D_0=1$) when rewinding is completed.
- (3) This input is effective in the MEM mode.
- (4) Disregard the RWD, EOP input when this input is used.

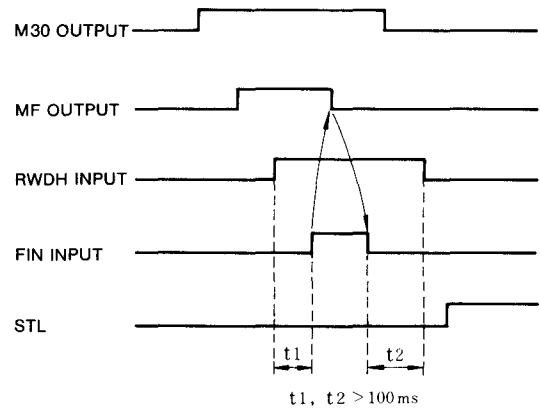

Fig. 19.26

20. J50M STANDARD I/O SIGNALS

20.1 LIST OF NC STANDARD I/O SIGNALS

Standard input/output signals are listed below.

For custom-built signals depending on the system, refer to the list of I/O signals provided for that particular system.

DISPLAY

D7	D6	D5	D4	D3	D2	D1	D0
0	0	0	0	1	1	1	1
↑				↑			
Contact open				Contact closed			

Input Signals (PLC→NC)

	D7	D6	D5	D4	D3	D2	D1	D0
#1300	EDT	MEM	MDI	T	S	H	J	RT
	EDIT	MEMORY	MANUAL DATA INPUT	TAPE	STEP	HANDLE	MANUAL FEED	RAPID TRAVERSE
#1301	OVC	ROV2	ROV1	OV16	OV8	OV4	OV2	OV1
	OVERRIDE CANCEL	RAPID TRAVERSE RATE OVERRIDE		FEEDRATE OVERRIDE				
#1302	-α	+α	-Z	+Z	-Y	+Y	-X	+X
	MANUAL FEED							
#1303	SPC	SPB	SPA	JV16	JV8	JV4	JV2	JV1
	SPINDLE SPEED OVERRIDE			MANUAL FEEDRATE OVERRIDE				
#1304	DRS	MP4	MP2	MP1	Hα	HZ	HY	HX
	DISPLAY RESET	HANDLE PULSE MULTIPLY			HANDLE AXIS			
#1305	AFL	MLK	OPT	DRN	BDT	DLK		SBK
	M-FUNCTION LOCK	MACHINE LOCK	OPTIONAL STOP	DRY RUN	BLOCK DELETE	DISPLAY LOCK		SINGLE BLOCK
#1306	SRN	F1	RET	TLMI	ZRN	EDTLK	*SP	ST
	PROGRAM RESTART	F1-DIGIT	RETRACT	TLMIN	ZERO RETURN	EDIT LOCK	FEED HOLD	CYCLE START
#1307	PINT	ZNG	ABS		Miα	MIZ	MIY	MIX
	PROGRAM INTERRUPTION	Z-AXIS LOCK	MANUAL ABSOLUTE		MIRROR IMAGE			
#1308	9BDT	8BDT	7BDT	6BDT	5BDT	4BDT	3BDT	2BD
	SPECIAL BLOCK DELETE							
#1309	ZRN2		4NG	EWS	PST		WSH	
	2ND ZERO RETURN		4TH AXIS NEGLECT	EXTERNAL WRITE	TOUCH SENSOR			

* Normally closed contacts

	D7	D6	D5	D4	D3	D2	D1	D0
#1310								

#1311								
-------	--	--	--	--	--	--	--	--

#1312	PLYBK	TCNT	SENSON	TLCTN	TLSKP	TLRST	ESC 1	ESC 0
	PLAYBACK	TOOL CUT COUNT INEFFECTIVE	TOUCH SENSOR EFFECTIVE	TOOL LIFE CONTROL			EXT STROKE CHECK SELECTION	
							0	0
							0	1
							1	0
							1	1
								Ineffective
								3rd axis
								4th axis
								5th axis

#1313	RWDH	FSCH	FSMEM	FSCM	SLPC			
	HIGH-SPEED REWIND & AUTO START	FEED/ SPINDLE CHANGE	FEED/ SPINDLE MEMORY	FEED/ SPINDLE EDIT MODE	SPINDLE LOOP COMMAND INPUT			

#1314	SPE	SPD	ROV 4		ECLM			
	SPINDLE OVERRIDE		RAPID TRAVERSE		EXT PROGRAM CLEAR			

#1315	MANINT	SSM	PPR		NTCRQ	TCFIN		
	MACHING INTERRUPT POINT RETURN	SENSOR STOP MODE	MACHING INTERRUPT POINT RETURN MODE		TOOL CHANGE REQUEST	TOOL CHANGE COMPLETED		

#1316	FFIN	FIN	RWD	EOP	ERS	EXTC	STLK	MRD
	COMMAND CYCLE	MST COMPLETION	EXTERNAL REWIND	END PROGRAM	EXTERNAL RESET	EXTERNAL TIME COUNT	CYCLE START	FUNCTION PREP COMPLETED

#1317	S-INV	S-FIN		SAGR	SOR	GRB	GRA	GST
	SPINDLE REVERSE	S-CODE COMPLETION		SPINDLE COINCIDENCE	SPINDLE INDEXING	GEAR SELECTION		GEAR SHIFT

#1318	ERR 2	ERR 1	ERR 0	SENS (G)	SENS (T)	EXOUT	EXVER	EXIN
	DEC TO STOP	IMMEDIATE STOP	SINGLE BLOCK STOP	GAP ELIMINATE	TOOL BROKEN	EXTERNAL OUTPUT	EXTERNAL COLLATION	EXTERNAL INPUT

#1319	*-Lα	*+Lα	*-LZ	*+LZ	*-LY	*+LY	*-LX	*+LX
	OVERTRAVEL							

#1320	HOFS				*ITα	*ITZ	*ITY	*ITX
	AUTO MODE HANDLE OFFSET				AXIS INTERLOCK			

* Normally closed contacts

20.1 LIST OF NC STANDARD I/O SIGNALS (Cont'd)

Input Signals (PLC→NC)

#1321	D7	D6	D5	D4	D3	D2	D1	D0
	*-ED α	*+ED α	*-EDZ	*+EDZ	*-EDY	*+EDY	*-EDX	*+EDX
EXTERNAL DECELERATION								
#1322	SONPB				*SVOF α	*SVOFZ	*SVOFY	SVOFX
	SERVO POWER ON	SERVO OFF						
#1323	UI 7	UI 6	UI 5	UI 4	UI 3	UI 2	UI 1	UI 0
	MACRO PROGRAM							
#1324	UI 15	UI 14	UI 13	UI 12	UI 11	UI 10	UI 9	UI 8
	MACRO PROGRAM							
#1325	ED 7	ED 6	ED 5	ED 4	ED 3	ED 2	ED 1	ED 0
	EXTERNAL DATA INPUT							
#1326	ED 15	ED 14	ED 13	ED 12	ED 11	ED 10	ED 9	ED 8
	EXTERNAL DATA INPUT							
#1327	EDCL	EDAS 2	EDAS 1	EDAS 0	EDSD	EDSC	EDSB	EDSA
	EXTERNAL DATA INPUT CONTROL SIGNAL							
#1328	EDAS 3				*DEC α	*DECZ	*DECY	*DECX
	EXTERNAL COORDINATE SHIFT ABS/INC	DECELERATION LS						
#1329		TL 64	TL 32	TL 16	TL 8	TL 4	TL 2	TL 1
	TOOL LIFE CONTROL TOOL GROUP NO. INPUT							
#1330								
#1331	SDI 8	SDI 7	SDI 6	SDI 5	SDI 4	SDI 3	SDI 2	SDI 1
	S 5-DIGIT COMMAND EXTERNAL INPUT							

* Normally closed contacts

	D7	D6	D5	D4	D3	D2	D1	D0
#1332	SDI 16	SDI 15	SDI 14	SDI 13	SDI 12	SDI 11	SDI 10	SDI 9

S 5-DIGIT COMMAND EXTERNAL INPUT

#1335	FSCLS	WSKAN 1						
-------	-------	---------	--	--	--	--	--	--

FS EDIT MANUAL
DATA CLEAR SKIP COMPLETED

#1338	WN 128	WN 64	WN 32	WN 16	WN 8	WN 4	WN 2	WN 1
-------	--------	-------	-------	-------	------	------	------	------

EXTERNAL WORK NO. SEARCH INPUT

#1341	SID 8	SID 7	SID 6	SID 5	SID 4	SID 3	SID 2	SID 1
-------	-------	-------	-------	-------	-------	-------	-------	-------

SPINDLE INDEX POSITION

#1342					SID 12	SID 11	SID 10	SID 9
-------	--	--	--	--	--------	--------	--------	-------

SPINDLE INDEX POSITION

#1343					SPCUT	SIDXI	SIDXINC	SIDX
-------	--	--	--	--	-------	-------	---------	------

SPINDLE INDEX STOP
SPINDLE INDEX RESTART
SPINDLE INDEX POSITION INC
SPINDLE INDEX REQUEST

Output Signals (NC→PLC)

	D7	D6	D5	D4	D3	D2	D1	D0
#1200	M 30	M 02	M 01	M 00	DEN	OP	SPL	STL

POSITIONING COMPLETED
FEEDING
TEMPORARY STOP
CYCLE START

#1201	2 ZPα	2 ZPZ	2 ZPY	2 ZPX	1 ZPα	1 ZPZ	1 ZPY	1 ZPX
-------	-------	-------	-------	-------	-------	-------	-------	-------

SECOND REFERENCE POINT LAMP

FIRST REFERENCE POINT LAMP

#1202	4 ZPα	4 ZPZ	4 ZPY	4 ZPX	3 ZPα	3 ZPZ	3 ZPY	3 ZPX
-------	-------	-------	-------	-------	-------	-------	-------	-------

FOURTH REFERENCE POINT LAMP

THIRD REFERENCE POINT LAMP

#1203								
-------	--	--	--	--	--	--	--	--

#1204								
-------	--	--	--	--	--	--	--	--

#1205			TLCHA	TLCHB	TCF	TCHGF		
-------	--	--	-------	-------	-----	-------	--	--

TOOL CHANGE
NEW TOOL SELECTION
TOOL CHANGE READ
TOOL CHANGE 1 GROUP COMPLETED

#1206							PRDO	SINVA
-------	--	--	--	--	--	--	------	-------

RAPID TRAVERSE OUTPUT
SPINDLE REVERSE OUTPUT

#1207					SIDXA	SIDXO	SLPS	G 93M
-------	--	--	--	--	-------	-------	------	-------

SPINDLE INDEX COMPLETION OUTPUT
SPINDLE INDEXING OUTPUT
SPINDLE GROUP STATUS OUTPUT
G 93 MODE OUTPUT

#1208	WSFTER	WSFTK						
-------	--------	-------	--	--	--	--	--	--

WORK COORDINATE DISPLAY SET

20.1 LIST OF NC STANDARD I/O SIGNALS (Cont'd)

Output Signals (NC→PLC)

	D7	D6	D5	D4	D3	D2	D1	D0
#1209	MANINTK					FSCLRK	FSCE	FSMD
	MACHING INTERRUPT POINT RETURN COMPLETRD					FS DATA CLEAR	FS MEMORY CHANGED	FS MEMORY EDIT MODE
#1210								
#1211					MIMGM α	MIMGMZ	MIMGMY	MIMGMX
	MIRROR IMAGE MODE							
#1212								
#1213								
#1214								
#1215	G84S							
	G74/G84 EXECUTING							
#1216	T8/T28	T7/T24	T6/T22	T5/T21	T4/T18	T3/T14	T2/T12	T1/T11
	T FUNCTION BINARY/BCD OUTPUT							
#1217	T16/T48	T15/T44	T14/T42	T13/T41	T12/T38	T11/T34	T10/T32	T9/T31
	T FUNCTION BINARY/BCD OUTPUT							
#1218	TAP	M04S	TLMO	G80S	EREND	ESEND	RST	AL
	TAPPING	SPINDLE REVERSING	TOOL LENGTH MEASUREMENT	CANNED CYCLE	EXTERNAL DATA INPUT COMPLETED	EXTERNAL DATA INPUT COMPLETED	RESET	ALARM

	D7	D6	D5	D4	D3	D2	D1	D0
#1219	SRV	SSP	FMF	EF	BF	TF	SF	MF
	SPINDLE REVERSE	SPINDLE STOP	MF	EXTERNAL	B- FUNCTION	T- FUNCTION	S- FUNCTION	M- FUNCTION
	FOR CANNED CYCLE							
#1220								
#1221								
#1222	M 8	M 7	M 6	M 5	M 4	M 3	M 2	M 1
	M-FUNCTION BINARY/BCD OUTPUT							
#1223	OS	EDTS	IER	4 NGC	AUTO	MAN	RDY	RWDS
	ORIENTA- TION	EDITING	INPUT ERROR	4TH AXIS NEGLECT	AUTO- MATIC	MANUAL	PREPARA- TION COMPLETED	REWIND
#1224	SDA 8/SB 8	SDA 7/SB 7	SDA 6/SB 6	SDA 5/SB 5	SDA 4/SB 4	SDA 3/SB 3	SDA 2/SB 2	SDA 1/SB 1
	S 5-DIGIT ANALOG OUTPUT/ S 4-DIGIT 12-BIT NON-CONTACT OUTPUT							
#1225	SDA 16	SDA 15	SDA 14	SDA 13	SDA 12/SB 12	SDA 11/SB 11	SDA 10/SB 10	SDA 9/SB 9
	S 5-DIGIT ANALOG OUTPUT/ S 4-DIGIT 12-BIT NON-CONTACT OUTPUT							
#1230								
#1231								
#1232	B 8/B 28	B 7/B 24	B 6/B 22	B 5/B 21	B 4/B 18	B 3/B 14	B 2/B 12	B 1/B 11
	B FUNCTION BINARY/BCD OUTPUT							
#1233	B 16/B 48	B 15/B 44	B 14/B 42	B 13/B 41	B 12/B 38	B 11/B 34	B 10/B 32	B 9/B 31
	B FUNCTION BINARY/BCD OUTPUT							
#1234	S 28	S 24	S 22	S 21	S 18	S 14	S 12/GRH	S 11/GRL
	S FUNCTION BCD OUTPUT						HIGH- SPEED GEAR	LOW- SPEED GEAR

20.1 LIST OF NC STANDARD I/O SIGNALS (Cont'd)

Output Signals (NC→NC)

	D7	D6	D5	D4	D3	D2	D1	D0	
#1235	S 48	S 44	S 42	S 41	S 38	S 34	S 32	S 31	S FUNCTION BCD OUTPUT
#1236	U 7	U 6	U 5	U 4	U 3	U 2	U 1	U 0	
#1237	U 15	U 14	U 13	U 12	U 11	U 10	U 9	U 8	MACRO PROGRAM
#1238									
#1239									
#1277	1 HP 7	1 HP 6	1 HP 5	1 HP 4	1 HP 3	1 HP 2	1 HP 1	1 HP 0	MONITOR HANDLE PULSES
#1278									
#1279									
#1280				SKIP	SN4	SN3	SN2	SN1	SYSTEM NO. SWITCH
#1281		0		ON-PB POWER ON SWITCH	OLD OVERLOAD	SVALM SERVO ALARM STOP	ESP EMER- GENCY	OHT OVERHEAT	
#1282	JSD	BALM	0	1	EXAXIS	PAGE 0	0	EXCMOS	CONTACT SIGNAL MONITOR FOR MAINTENANCE 0: SR 51 BOARD PROVIDED 1: SR 51 BOARD NOT PROVIDED
	JSD 0: NOT PROVIDED 1: PROVIDED	BATTERY ALARM MONITOR		CONSTANT "1"	OPTION AXIS BOARD MONITOR 0: SR 51 BOARD PROVIDED				
#1283					SNS 4	SNS 3	SNS 2	SNS 1	SYSTEM NO. SETTING

	D7	D6	D5	D4	D3	D2	D1	D0
#1284	SVON	NRD						
	SERVO POWER ON	NC READY						
#1285	0	0	0	0	0	0	0	1
	CONSTANTS "1"							
#1286	0	0	0	0	0	0	0	0
	CONSTANTS "0"							
#1287						PCS	PBS	PAS
						PG MONITOR FOR SPINDLE		
#1288	TGONX	PCX	PBX	PAX	*ALX	*OLX	FUX	SRDX
	PG MONITOR FOR X-AXIS				SERVO UNIT MONITOR FOR X-AXIS			
#1289	TGONY	PCY	PBY	PAY	*ALY	*OLY	FUY	SRDY
	PG MONITOR FOR Y-AXIS				SERVO UNIT MONITOR FOR Y-AXIS			
#1290	TGONZ	PCZ	PBZ	PAZ	*ALZ	*OLZ	FUZ	SRDZ
	PG MONITOR FOR Z-AXIS				SERVO UNIT MONITOR FOR Z-AXIS			
#1291	TGON 4	PC 4	PB 4	PA 4	*AL 4	*OL 4	FU 4	SRD 4
	PG MONITOR FOR 4TH AXIS				SERVO UNIT MONITOR FOR 4TH AXIS			
#1292								
#1293				ZNGC	ABSC	EDTLKC		
				Z-AXIS NEGLECT	MANUAL ABSOLUTE	EDIT LOCK		
#1294	AFLC	MLKC	OPTC	DRNC	BTDC	DLKC	STLKC	SBKC
	AUX FUNCTION LOCK	MACHINE LOCK	OPTIONAL STOP EFFECTIVE	DRY RUN	OPTIONAL BLOCK SKIP EFFECTIVE	DISPLAY LOCK	START LOCK	SINGLE BLOCK
#1295			PLBKC		MlαC	MIZC	MIYC	MIXC
			PLAY- BACK		MIRROR IMAGE AXIS			
#1296								
#1297	ALM 28	ALM 24	ALM 22	ALM 21	ALM 18	ALM 14	ALM 12	ALM 11
	ALARM CODE MONITOR (LOWER 2-DIGIT BCD CODE)							
#1298					ALM 38	ALM 34	ALM 32	ALM 31
					ALARM CODE MONITOR			

SETTING MONITOR

20.2 DETAILS OF SIGNALS

20.2.1 INPUT SIGNALS FOR CYCLE START (ST) AND STOP (*SP) OUTPUT SIGNALS FOR CYCLE START (STL) AND FEEDHOLD (SPL)

- (1) With the control in any of the TAPE, MEMORY, and MDI modes, when the input contact ST is closed and opened, the control starts automatic operation control to execute the part program, and at the same time, turn on the STL output signal for cycle start. However, an ST input is neglected under the following condition.
 - (a) While the control is in an alarm state. (While an alarm output or an input error output is on.)
 - (b) While the feedhold *SP input contact is open.
 - (c) While the external reset ERS input contact is closed.
 - (d) While the RESET button on the MDI & CRT panel is being pushed.
 - (e) While the system No. switch is in any state except for 0 and 4.
 - (2) When the following state is entered after cycle start, the control completes operation control, and turns off the STL output.
 - (a) When a part program has been executed by manual data input in the MDI mode.
 - (b) When one block of a part program has been executed with the single block (SBK) input contact closed.
 - (c) When the program end (EOP) input contact has been closed by an M command of a part program.
 - (3) When the feedhold input contact "* SP" is opened during automatic operation, the automatically controlled motions, etc. are interrupted, and at the same time the cycle start output STL is turned off and the feedhold output SPL is turned on. While a block of thread cutting instruction is being executed, the feedhold input is neglected.
 - (4) When the feedhold input contact *SP is closed, and cycle start input contact ST is closed and opened, temporary stop SPL is turned off, and automatic operation is restarted. The cycle start output STL is turned on also.
- Timing chart for input of cycle start (ST), feedhold (*SP), and cycle start (STL) and temporary stop (SPL) is shown in Fig. 20.1.

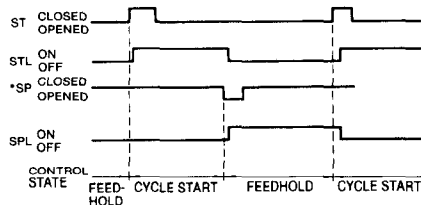

Fig. 20.1

Notes :

1. Be sure to keep the cycle start (ST) and feedhold (*SP) input contacts closed or open at least for 100 ms. If the duration is shorter than this, the input may sometimes be neglected.

2. When the feedhold (*SP) input contact is opened, with the control waiting for the completion of the M, S, T command (waiting for FIN input), feedhold (SPL) output is turned on, but when the M, S, T, command completion (FIN) input contact is opened, the control enters feedhold state.

20.2.2. INPUT AND OUTPUT FOR CONTROL OPERATION MODES (JOG, H, S, T, MDI, MEM, EDT, AUT, MAN)

(1) Operation Mode Input

The following six operation modes of the control are selected by the respective input contacts.

JOG: Manual jog mode	}	Manual operation
H: Manual handle		
S: Manual step feed mode		
T: Tape operation mode	}	Automatic operation mode
MDI: Manual data input operation mode		
MEM: Memory operation mode		
EDT: Program editing mode		

When any of the input contacts is closed, the corresponding operation mode is turned on.

(a) JOG: Manual jog mode input

When the JOG input contact is closed, and other mode input contacts are opened, the control enters the manual jog mode, and the machine is jogged in the respective directions in response to the input of +X, -X, +Y, -Y, +Z, -Z, +α and -α signals.

(b) H: Manual HANDLE mode input

When the H input contact is closed, and other mode input contacts are opened, the control enters the manual handle mode and the machine will be fed manually by the manual pulse generator according to the specified multiplication factor on the selected axis.

(c) S: Manual STEP feed mode

When the S input contact is closed, and other mode input contacts are opened, the control enters the manual step feed mode and the machine will be fed in steps.

(d) T : Tape operation mode

When the T input contact is closed and other mode input contacts are opened, the control enters the tape operation mode, and the machine will be controlled by the tape commands read by the tape reader.

(e) MDI: Manual data input operation mode input

When the MDI input contact is closed, and other mode input contacts are opened, the control enters the manual data input mode, and part programs will be written or the machine will be operated through MDI.

(f) MEM: Memory operation mode input

When the MEM input contact is closed, and other mode input contacts are opened, the control enters the memory operation mode, and the machine will be controlled by part programs stored in the memory.

(g) EDT: Program edit mode

When the EDT input contact is closed and other operation mode input contacts are open, the control enters the program edit mode, and it can store part programs into the memory, correct and change them.

(2) Operation Mode Output

The control outputs the following signals to inform the current operation mode.

(a) AUT: Automatic operation mode output

This output signal is turned on when the control is in the T (tape operation), MEM (memory operation), or MDI (manual data input operation) mode.

(b) MAN: Manual operation mode output

This output signal is turned on when the control is in the H (manual handle operation), S (manual step operation) or JOG (manual jog) mode.

(c) EDTS: Editing output

This output signal is turned on when the control is in the EDT (program editing) mode, and also performing and editing operation (part program reading, collation, punching, and stored program changing and other processing).

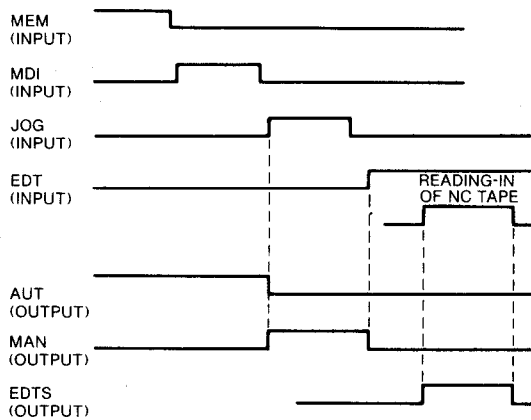

Fig. 20.2

Notes :

1. When any operation-mode-input except manual operation mode is given during NC program operation in the memory operation mode, the control stops the execution of the part program after the execution of the current block. The same applies to the part program operation in the tape and MDI mode.

2. When a manual-operation-mode-input contact is closed during the execution of a part program in the memory operation mode, the following changes take place.

i. Motion command

The current motion stops after deceleration, and the program is interrupted. The remaining program can be restarted when the automatic operation mode is turned on again and the cycle start (SP) input contact is closed.

ii. M, S, T command

The sampling outputs (MF, SF, TF) and the M code outputs are turned off, and the M, S, T command is regarded to have been executed completely.

Even when the control is returned to the automatic operation mode, the interrupted M, S, T command is not resumed.

3. When an automatic operation mode or program editing mode input contact is closed during motion in the manual operation mode, the motion decelerates and stops.

4. When any of these operation mode input contacts is closed, that mode becomes effective.

Under other input states, the previous operation mode remains effective. When no operation-mode-input-contacts is closed after the energization, or when two or more operation-mode-input-contacts are closed, the control enters the manual jog mode.

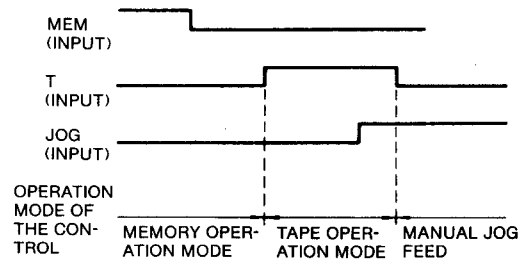

Fig. 20.3

5. When a manual operation mode input contact is closed during the tapping process in a part program, the automatic operation mode is retained while the thread is being cut.

20.2.3 MANUAL RAPID FEEDING SELECTION (RT) INPUT

When the control is in the manual jog mode and this input is closed, feeding in the manual feeding direction “+X”, “-X”, “+Y”, “-Y”, “+Z”, “-Z”, “+α”, or “-α” is performed in the rapid feeding speed.

19.2.4 MANUAL FEED AXIS DIRECTION SELECTION (+X, -X, +Y, -Y, +Z, -Z, +α, -α) INPUT

These inputs specify the motion direction and the axis to be moved when the control is in the manual jog mode, RT mode or manual step feed mode. Each axis moves when either of plus or minus direction axis contact is closed. If all the axes are selected, maximum number of simultaneous controllable axes will work.

When both plus and minus direction contacts for each axis are closed or opened, the selected axis cannot move or decelerates to stop during motion.

20.2.5 MANUAL HANDLE / STEP MULTIPLICATION FACTOR (MP1, MP2, MP4) INPUT

When the control is in the manual handle / manual step feed mode, the motion distance per step is determined by these input signals.

Table 20.1

MP1	MP2	MP4	Manual Step Feed	Manual Feed Handle
0	0	0	1 pulse/step	
1	0	0	10 pulses/step	
0	1	0	100 pulses/step	
1	1	0	1000 pulses/step	100 pulses/step
0	0	1	10,000 pulses/step	100 pulses/step
1 or 0		1	100,000 pulses/step	100 pulses/step

1: Closed, 0: Open

(1) Manual Handle Feed Axis Selection (HX, HY, HZ, Hα,) Input

This is the input signal for selecting the motion axis for the motion by the manual pulse generator, with a control provided with a manual pulse generator.

When the HX input contact is closed and the HY, HZ and Hα input contacts are open, the motion takes place along the X-axis. When the HY input contact is closed and the HX, HZ and Hα input contacts are open, the motion takes place along the Y-axis. When the HZ input contact is closed and HY, HZ and Hα input contacts are open, the motion takes place along the Z-axis. When the Hα input contact is closed and HX, HY and HZ input contacts are open, the motion takes place along the α-axis.

If any input other than above is provided, any axis will not move.

20.2.6 FEEDRATE OVERRIDE (OV1, OV2, OV4, OV8, OV16) INPUT AND FEED OVERRIDE CANCEL (OVC) INPUT

(1) These input signals are for specifying override speeds between 0 and 200% at 10% intervals on the programmed speeds.

Table 20.2

1: CLOSED, 0: OPEN					Feedrate Override (Automatic Operation Mode)
OV1	OV2	OV4	OV8	OV16	
0	0	0	0	0	0%
1	0	0	0	0	10%
0	1	0	0	0	20%
1	1	0	0	0	30%
0	0	1	0	0	40%
1	0	1	0	0	50%
0	1	1	0	0	60%
1	1	1	0	0	70%
0	0	0	1	0	80%
1	0	0	1	0	90%
0	1	0	1	0	100%
1	1	0	1	0	110%
0	0	1	1	0	120%
1	0	1	1	0	130%
0	1	1	1	0	140%
1	1	1	1	0	150%
0	0	0	0	1	160%
1	0	0	0	1	170%
0	1	0	0	1	180%
1	1	0	0	1	190%
0	0	1	0	1	200%
1	0	1	0	1	220%
0	1	1	0	1	240%
1	1	1	0	1	260%
0	0	0	1	1	280%
1	0	0	1	1	300%
0	1	0	1	1	340%
1	1	0	1	1	380%
0	0	1	1	1	420%
1	0	1	1	1	460%
0	1	1	1	1	500%
1	1	1	1	1	540%

Note :

For the control with feedrate override option, feedrate override is adjustable between 220% and 540%.

(2) Feed Override Cancel (OVC) Input

This is the input for fixing the feedrate override at 100%. When the OVC input contact is closed, the feedrate in part program execution in the automatic operation modes is locked at the programmed value, irrespective of the override input conditions.

20.2.7 MANUAL JOG FEEDRATE SELECTION (JV1, JV2, JV4, JV8, JV16) INPUT

(1) These inputs specify the manual jog feedrates in the manual JOG mode.

(2) The manual jog feedrates can be used as the feedrates for part program dry run execution in the automatic operation mode. For details, refer to "20. 2. 14 Dry Run (DRN) Input."

Table 20.3

1: CLOSED, 0: OPEN					Manual Jog Feedrate (Manual Operation Mode) Parameter Setting
JV1	JV2	JV4	JV8	JV16	
0	0	0	0	0	#6233
1	0	0	0	0	#6234
0	1	0	0	0	#6235
1	1	0	0	0	#6236
0	0	1	0	0	#6237
1	0	1	0	0	#6238
0	1	1	0	0	#6239
1	1	1	0	0	#6240
0	0	0	1	0	#6241
1	0	0	1	0	#6242
0	1	0	1	0	#6243
1	1	0	1	0	#6244
0	0	1	1	0	#6245
1	0	1	1	0	#6246
0	1	1	1	0	#6247
1	1	1	1	0	#6248
0	0	0	0	1	#6249
1	0	0	0	1	#6250
0	1	0	0	1	#6251
1	1	0	0	1	#6252
0	0	1	0	1	#6253
1	0	1	0	1	#6254
0	1	1	0	1	#6255
1	1	1	0	1	#6256
0	0	0	1	1	#6257
1	0	0	1	1	#6258
0	1	0	1	1	#6259
1	1	0	1	1	#6260
0	0	1	1	1	#6261
1	0	1	1	1	#6262
0	1	1	1	1	#6263
1	1	1	1	1	#6264

20.2.8 RAPID FEEDRATE OVERRIDE (ROV1, ROV2) INPUT

These input are for determining the rapid feedrates, i.e., the positioning speed when executing programs in the automatic operation modes, and the motion speed in the manual jog mode when the RT input contact is closed.

Table 20. 4

Input State	ROV1	1	0	1	0
	ROV2	1	1	0	0
Rapid Feedrate	X-axis	#6280 Setting speed	#6280 Setting $\times \frac{1}{2}$ speed	#6280 Setting $\times \frac{1}{4}$ speed	#6231 Setting speed
	Y-axis	#6281 Setting speed	#6281 Setting $\times \frac{1}{2}$ speed	#6281 Setting $\times \frac{1}{4}$ speed	
	Z-axis	#6282 Setting speed	#6282 Setting $\times \frac{1}{2}$ speed	#6282 Setting $\times \frac{1}{4}$ speed	
	α -axis	#6283 Setting speed	#6283 Setting $\times \frac{1}{2}$ speed	#6283 Setting $\times \frac{1}{4}$ speed	

1: Closed, 0: Open

20.2.9 REFERENCE POINT RETURN CONTROL I/O SIGNALS (ZRN, *DECX, *DECZ, *DEC α , *ZPX, ZPY, ZP α)

These are input and output signals for bringing the machine to the machine reference point upon the energization of the control.

The following reference point return methods are available.

(1) Grid Method

After turning on the power supply, when the manual jog mode is turned on, and the manual reference point return input contact ZRN is closed, the direction of axis motion set by parameter (D0, D1, D2, D3) will result in the reference point return motion as shown below. (The same applies to the execution of G28 in the automatic operation modes.)

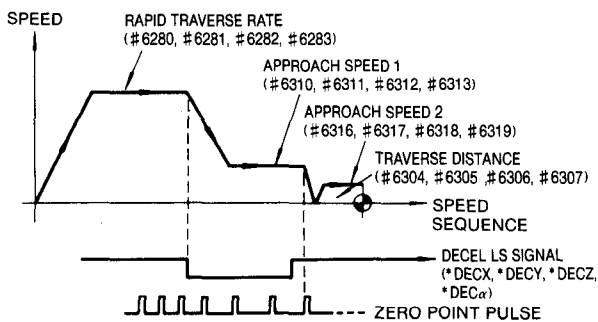

Fig 20. 4

When once the machine is turned to the reference point in high-speed reference point return (automatic, return), the return motion, thereafter will be in the positioning motion to the determined reference point. See Fig. 20. 5.

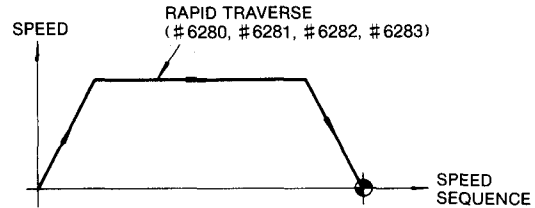

Fig. 20.5 Reference Point Return Motion after First Power ON

(2) X, Y, Z and Reference Points (ZPX, ZPY, ZPZ, ZP α) Output

While the machine is remaining at the reference point after the reference point return motion or positioning to the reference point, the ZPX, ZPY, ZPZ and ZP α output contacts are closed.

If the actual position is within ± 3 pulses from the reference point due to the use of metric input in the inch output system or the use of inch input in the metric output system, the ZPX, ZPY, ZPZ and ZP α output contacts are closed.

(3) 2nd Reference Point (2ZPX, 2ZPY, 2ZPZ, 2ZP α) Output

When the machine has been positioned to the 2nd reference point by the execution of the part program command G30 in the auto-matic operation mode, the 2ZPX, 2ZPY, 2ZPZ and 2ZP α output reays are closed, and remain closed as long as the machine remains at this point. The end reference point is defined by the distance from the reference point as set by parameters (#6612, #6613, #6614, #6615).

(4) 3rd Reference Point (3ZPX, 3ZPY, 3ZPZ, 3ZP α) Output

When the machine has been positioned to the 3rd reference point by the execution of the part program command G30P3 in the automatic operation mode, the 3ZPX, 3ZPY, 3ZPZ and 3ZP α output relays are closed. The 3rd reference point is defined by the distance from the reference point as set by parameters (#6618, #6619, #6620, #6621).

(5) 4th Reference Point (4ZPX, 4ZPY, 4ZPZ, 4ZP α) Output

When the machine has been positioned to the 4th reference point by the execution of the part program command G30P4 in the automatic operation mode, the 4ZPX, 4ZPY, 4ZPZ and 4ZP α output relays are closed. The 4th reference point is defined by the distance from the reference point as set by parameters (#6624, #6625, #6626, #6627).

20.2.10 MANUAL ABSOLUTE ON / OFF (ABS) INPUT

During the execution of part program in the automatic operation mode, the control stores the command values in an internal command value register (command values are displayed on the 1st CRT area), and the displacement distance between the stored value and the coordinate value in the part program.

Since the control must also control the current position, it controls the current values in the absolute coordinate system to be displayed in the 2nd CRT area. The coordinate system is defined by a coordinate system setting command.

This input is for determining whether the current value in the absolute coordinate system is transferred to the command value register or not at the start of the execution of the respective blocks of part programs in the automatic operation mode.

- When ABS input relay is open: Does not transfer.
- When ABS input relay is closed: To be transferred, except when circuit interpolation is used.

The motion path after a manual control intervention in the automatic operation mode is changed as follows by an ABS input.

(1) When ABS Input Relay is Open

The motion path after an intervention by manual axial motion, is the one shifted parallel from the original path by the distance covered by the manual motion.

```
G90 G01 Z20.000 FΔΔ:
X20.000 Y30.000 ← ①
X10.000 Y40.000
```

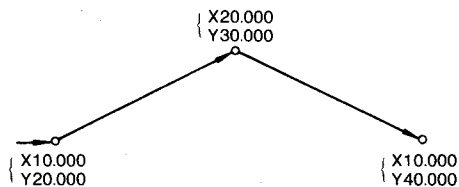

① When the machine is manually moved during a block.

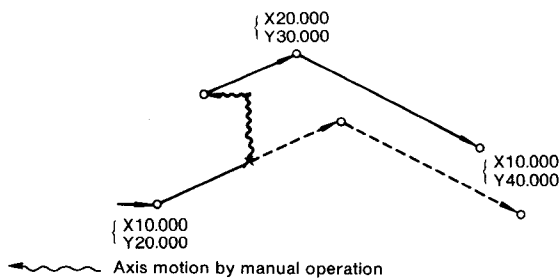

Fig. 20.6

(2) When ABS Input Relay is Closed.

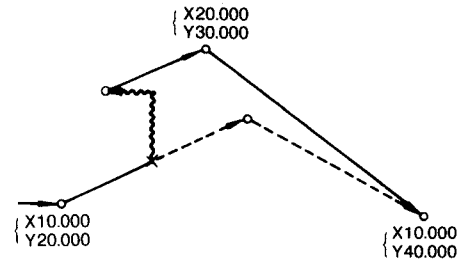

Fig. 20.7

(3) Supplementary Description

In the following cases, the control current value in the absolute coordinate system (coordinate system displayed in the CRT current value 2nd area, or the one determined by coordinate system setting instructions) to the command value register unconditionally.

- (a) RESET operation: MDI panel RESET key--on or external reset (ERS) input contact closed
- (b) End of program: Program reset through end of program (EOP) input contact closing by M02, M30 execution
- (c) Automatic return to reference point: Execution of G28 command

After transferring the current value in the absolute coordinate system to the command value register, manual axial movement is reflected on the automatic axial movement even when the ABS input contact is closed.

When the blok ① is searched again by the RESET operation after axial motions by manual operation, the following motion takes place.

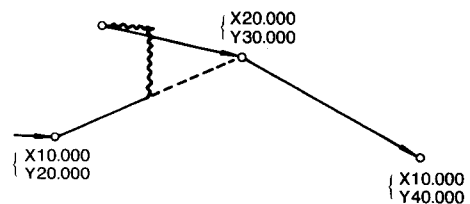

Fig. 20.8

20.2.11 SINGLE BLOCK (SBK) INPUT

This input is for executing part programs by one block in the automatic operation mode. With the control in the automatic operation mode, and the SBK input contact closed, when an automatic operation cycle is started, the part program is executed only by one block, and the machine stops. When the SBK input contact is closed during the execution of a part program, the control stops the machine after the execution of the current block.

For details of the use of single block during the execution of multiple cycles, macro programs, refer to the YASNAC J50M Instruction Manual (TOE-C843-12.30).

20.2.12 OPTIONAL BLOCK DELETE (BDT, BDT2-BDT9) INPUT

This input is for determining whether data between “/” and “EOB” in a part program is executed or neglected when the part program contains “/”.

Table 20.5

	Neglected Data between
BDT INPUT CLOSED	“/” or “/1” and “EOB” (End of block)
BDT2 INPUT CLOSED	“/2” and “EOB”
BDT3 INPUT CLOSED	“/3” and “EOB”
BDT4 INPUT CLOSED	“/4” and “EOB”
BDT5 INPUT CLOSED	“/5” and “EOB”
BDT6 INPUT CLOSED	“/6” and “EOB”
BDT7 INPUT CLOSED	“/7” and “EOB”
BDT8 INPUT CLOSED	“/8” and “EOB”
BDT9 INPUT CLOSED	“/9” and “EOB”

Notes:

1. Data can be neglected only when part programs are executed. When storing or processing part programs, this input has no effect.
2. Whether data may be neglected or not depends on the state of the optional block skip input relay when the block containing “/” in a part program is stored in the buffer. Therefore, when controlling the optional delete input relay by an external circuit with the use of the auxiliary function, take care to set the input state before the block containing “/” is stored in the buffer.

20.2.13 MACHINE LOCK (MLK) AND DISPLAY LOCK (DLK) INPUT

(1) Machine Lock (MLK) Input

This is the input for preventing the output of control output pulses to the servo unit. While the MLK input contact is closed, even when the logic circuit distributes pulses in the automatic and manual operation modes, the machine does not move. As the logic circuits distribute pulses, the current value display changes with the instructions. The controller must be stopped while MLK contact is closed or opened. The operation is not influenced except during block stop or feedhold state.

(2) Display Lock (DLK) Input

This input is for preventing the output pulses of the control from being displayed on the external current value display. While the DLK input contact is closed, even when the machine is controlled automatically or manually, the external current value display (CRT-POS “EXTERNAL”) does not change.

20.2.14 DRY RUN (DRN) INPUT

This input is for changing the feed rates of the tools during the execution of part programs in the automatic mode to the rates selected by the manual continuous feed selection inputs (JV1, 2, 4, 8 and 16).

While the DRN input contact is closed, the feedrate during the execution of part programs in the automatic mode are changed from the programmed ones to the ones selected by the manual continuous feed selection inputs.

When the DRN input contact is closed or opened during the automatic operation of the control, the following change takes place.

During mm/rev feeding:

No change of feedrate for the current block.

During mm/min feeding:

Feedrate changes even during the current block.

NOTE

When parameter #6006 D2 is set to 1, while the DRN input contact is closed, the feedrate in positioning command is changed to a manual continuous feedrate.

20.2.15 PROGRAM RESTART (SRN) INPUT

This input is used when a part program is to be started again after interruption. Close the SRN input contact, turn on the memory mode, and search the sequence number of program restart by the NC operator's panel. The M, S, T codes present between the leading end of the program and the searched sequence number are displayed on the CRT.

For the details of the uses of the uses of the PST input, refer to Par. 5. 2. 4, program Restart in YASNAC J50M Instruction Manual (TOE-C843-12.30).

20.2.16 EDIT LOCK (EDTLK)

This is the input for preventing the change of the contents of the stored part program. While the EDTLK input contact is closed, the following operations among the ones in the program edit mode are prohibited.

1. Storing part programs by the MEM DATA "IN" key.
2. The change, addition and deletion of part programs in the memory are made with the EDIT "ALT," "INS" and "ERS" keys.

20.2.17 AUXILIARY FUNCTION LOCK (AFL) INPUT

This is the input for omitting the M, S, T, function in executing part programs in the automatic operation mode.

While the AFL input contact is closed, the control ignores M. S. T. instructions of programs when executing part programs. However, M code decoded outputs (M00R, M01R, M02R, M30R) are output.

When the AFL input contact is closed or opened during the execution of part programs, the change becomes effective from the block subsequent to the current block.

NOTE

Analog outputs at S-command 5 digits are provided as commanded when "AFL" input is closed.

20.2.18 OVERTRAVEL (*+LX, *-LX, *+LY, *-LY, *+LZ, *-LZ, *+L α , *-L α ,) INPUT

These input signals are for signifying the arrival of the machine slides to their respective stroke ends. When these overtravel input contacts are opened, the machine slides stop motion as shown below, and close the alarm (ALM) output contact and at the same time, displays alarm on the CRT.

Table 20. 6

	Manual Operation Mode	Automatic Operation Mode
* +LX Input opened	Motion stop in +X direction	Motion stop of all axes-in-all directions
* -LX Input opened	Motion stop in -X direction	
* +LY Input opened	Motion stop in +Y direction	
* -LY Input opened	Motion stop in -Y direction	
* +LZ Input opened	Motion stop in +Z direction	
* -LZ Input opened	Motion stop in -Z direction	
* +L α Input opened	Motion stop in + α direction	
* -L α Input opened	Motion stop in - α direction	

*Activating at LOW. (Normally closed contacts.)

When an overtravel input contact is opened, move the machine in the reverse direction in the manual operation mode (manual, jogging or manual pulse generator) to close the contact, and then, make the RESET operation to clear the alarm output and display.

NOTE

Even when the overtravel input contacts are opened, the M code reading output MF, S code reading output SF, and the T code reading output TF are not turned off. If the motion by M codes, S codes or T codes is required to be stopped by overtravelling inputs, interlock the motion with external sequence.

20.2.19 MACHINE-READY (MRD) INPUT

This input informs that the external heavy-current circuit is ready. When MRD input is closed after closing of Servo Power Input/Output (SVON) from the power-on/off unit of the control after the power is turned on, the control is ready and "RDY" is displayed on the CRT screen.

When MRD input is opened with the control being ready, the control is put in the alarm state (alarm code "280" is displayed), thereby stopping the operation.

20.2.20 EXTERNAL RESET (ERS) INPUT AND RESET ON (RST)OUTPUT

ERS is the input to reset the control. When ERS input is closed, the control stops all of its operation, closing reset On outputs RST for one second. The output signals are opened except for the following.

Table 20.7

Output Signals	Output at ERS Input Closed
AUT, MAN 1ZPX, 1ZPY, 1ZPZ 1ZPα, 2ZPX, 2ZPY, 2ZPZ 2ZPα, 3ZPX, 3ZPY, 3ZPZ 3ZPα, 4ZPX, 4ZPY, 4ZPZ 4ZPα, 4NGC, 5NGC SO1-2, PO1-2	Previous conditions kept.
RST	Output contact is closed for one second while ERS input contact is closed or opened.
AL	Contact kept closed unless alarm causing factor is cleared.
SB1-SB12 SDA1-SDA16 S11-S48 B11-B48	Previous conditions kept.
UO0-15	Previous conditions kept.

Note : When ERS input is closed, the control is put in the label skip state. However, memory is rewound, while the tape is not.

20.2.21 INTERLOCK (STLK) INPUT

This input stops the spindle travel in the automatic operation mode. As long as "STLK" input is closed, spindle travel will not start by closing "ST" input.

20.2.22 ALARM (ALM) OUTPUT AND EXTERNAL ERROR DETECT (ERR0-2) INPUTS

(1) Alarm (ALM) Output

These outputs inform that the control is in the alarm state.

ALM: This output is closed on detection of alarm. (However, the alarm for the fault of the logic circuitry in the control is not included.)

These outputs are opened again when the cause of the detected alarm has been removed and RESET operation is performed.

(2) External Error Detect (ERR0, ERR1, ERR2) Inputs

These inputs put the control in the alarm state from the outside.

ERR0: When this input is closed, the control displays alarm code "180" and is put in the alarm state. If this input is closed during the execution of the part program in the automatic operation mode, the execution is stopped on completion of the block being executed.

ERR1: When this input is closed, the control displays alarm code "500" and is put in the alarm state. If this input is closed during the execution of the part program in the automatic operation mode, the tool travel is immediately stopped.

ERR2: When this input is closed, the control displays alarm code "400" and is put in the alarm state. If this input is closed during the execution of the part program in the automatic operation mode, the tool travel is immediately slowed down and stopped.

20.2.23 MIRROR IMAGE (MIX, MIY, MIZ, MIα)

This input inverts the travelling direction in the automatic operation mode. This input is effective with setting #6000 D0-D4 at "0."

When automatic activation is performed with MIX, MIY, MIZ and MIα input closed, the directions of X-, Y-, Z-, 4th, 5th axis are made opposite to the specified direction.

Mirror image input does not affect the axis travel in the manual operation mode. For details, refer to 2. 8. 5 Mirror Image ON/OFF (M95, M94) in YASNAC J50M Instruction Manual (TOE-C843-12.30).

20.2.24 M, S, T AND *B CODES (M01 THROUGH M08, S11 THROUGH S28, T11 THROUGH T48, B11 THROUGH B38, MF, SF, TF, *BF, FIN) INPUTS/OUTPUTS

(1) M, S, T and *B Codes Output and M, S, T and *B Codes Reading Outputs

Table 20. 8

M code output	M01-M08
S code output	S11, S12, S14, S18, S21, S22, S24, S28, S31, S32, S34, S38, S41, S42, S44, S48
T code output	T1, T2, T3, T4, T5, T6, T7, T8, T9, T10, T11, T12, T13, T14, T15, T16, T18, T21, T22, T24, T28, T31, T32, T34, T38, T41, T42, T44, T48
B code output	B1, B2, B3, B4, B5, B6, B7, B8, B9, B10, B11, B12, B13, B14, B15, B16, B18, B21, B22, B24, B28, B31, B32, B34, B38, B41, B42, B44, B48
M code reading output	MF
S code reading output	SF
T code reading output	TF
B code reading output	BF

These are outputs for the M, S, T and *B commands specified by the part program at its execution in the automatic operation mode. If any of M, S, T and *B commands is found at the execution of the part program in the automatic operation mode, the control outputs it in a BCD or binary code according to the value that follows the detected command (M = 2 digits/3 digits, S = 2 digits, T = 4 digits, *B = 3 digits).

Then, after the elapse of the time set in parameter (#6220), the M, S, T and *B code reading outputs are closed.

NOTE

M code or MF code of M commands (M90 through M99) in the logical circuit processing will not output.

(2) M Decode (M00R, M01R, M02R, and M30R) Output

When any of M commands "M00," "M01," "M02," and "M30" is executed, the corresponding decoded output "M00R," "M01R," "M02R," or "M30R" is output in addition to the M code output and the M code reading output.

NOTE

When an M command for decoded output and a move command are specified in the same block, the M code output is provided at the start of the block, while the decoded output is provided after completion of the move command.

(3) M, S, T and *B Functions Completion (FIN) Inputs

These inputs give the completion of M, S, T and *B commands to the control. When FIN input is closed while the M, S, T and *B code reading (MF, SF, TF and *BF) outputs are closed, they are opened. If FIN input is opened again after making sure of their opening, the control assumes that the M, S, T or *B command has been completed, starting the operation of the next step.

NOTE

When FIN input is closed then opened, the M code output and the M decoded output are all opened, but the S, T and *B code outputs remain as they are without change.

(4) Time Chart of M, S, T and *B Signals

(a) M command

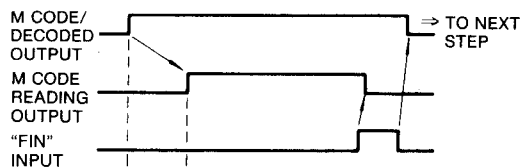

(b) S/T/*B command

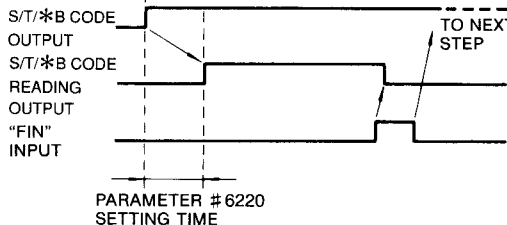

Fig. 20.9

(c) If a move command and an M, S, T or *B command are specified in the same block, the move operation and the M, S, T or *B operation are executed simultaneously.

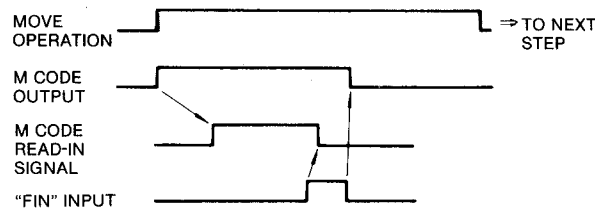

Fig. 20.10

20.2.25 POSITIONING COMPLETION (DEN) OUTPUTS

These outputs inform the completion of a move command when an M, S, T or *B command and the move command have been specified in the same block at the execution of a part program in the automatic operation mode.

The block in which an M, S, T or *B command and a move command are specified at the same time is executed, if the M, S, T or *B command is not completed at the termination of the move command, positioning completion output DEN is closed.

When FIN input is closed then opened and the M, S, T or *B command is completed, the positioning completion outputs are opened.

20.2.26 TRAVEL ON (OP), TAPPING AND CANNED CYCLE ON (G80S) Outputs

(1) Travel ON (OP) OUTPUTS

With these outputs, the control informs that the tool is traveling during the execution of a part program in the automatic operation mode. These outputs are closed when the machine starts.

The output is turned off by RESET operation (including RESET by M02, M30 command).

(2) Tapping (TAP) Output

With these outputs, the control informs that tapping is being performed during the execution of part program in the automatic operation mode.

These outputs are given when tapping starts from point R to point Z and turned off when tapping from point Z to point R is completed.

(3) Canned Cycles (G80S) Output

This output indicates that the control is performing canned cycles. The output G80S is given when canned cycle block starts and turned off by canned cycle block cancellation.

20.2.27 END-OF-PROGRAM (EOP) INPUT, REWIND (RWD) INPUT, AND REWIND ON (RWDS) OUTPUTS

(1) End-Of-Program (EOP) and Rewind (RWD) Inputs

With these outputs, the control determines what processing is to be performed at completion of an M02 or M30 command. The control performs the following processing depending on the state of EOP and RWD inputs when completion input FIN for an M02 or M30 command is opened then closed:

Table 20. 9

EOP	RWD	Processing
1	1	The control is standby after rewinding part programs and resetting programs.
1	0	The control is at standby after resetting programs.
0	1	The control is at standby after resetting part programs.
0	0	The control is at standby

1: Closed, 0: Open

Notes :

- Program reset provides the same effects as with pressing of RESET key on MDI panel and the reset operation by closing External Reset (ERS) input.
In the program reset, however, the NC memory rewind operation is not performed.
- Some parameters make resetting output RST "closed" for a second at program resetting.
#6009 (D4)
When both RWD and EOP are input or only EOP is input at M02/M30:
1: RST output provided
0: RST output not provided

(2) Rewind ON (RWDS)

With these outputs, the control informs that the part program is being rewound. If the part program is rewound by RWD input for an M02 or M30 command, RWDS2 is closed during the rewinding operation.

To use these outputs, set parameter #6007 D4 to "1." At "0," they are not given from the control.

20.2.28 EXTERNAL DATA INPUT (ED0 THROUGH ED15, EDSA THROUGH EDSO, EDSA0 THROUGH EDSA2, EDCL, EREND AND ESEND) INPUTS/OUTPUTS

(1) These inputs/outputs are used to make the machine perform the following functions by external inputs:

(a) External work number search

External inputting of 4-digit program (1 to 9999 BCD) selects the work number desired.

(b) External tool compensation input

This external input signals can command compensation values for tool length and diameter.

(c) External work coordinate system shift

The work coordinate system shift value can be entered externally.

Externally entered axis correction value is added to the shift value of the specified axis programmed by G54 to G59 and the result is stored as a new shift value.

(2) Input/Output Signals for Inputting External Data

(a) External data inputs (ED0 to ED15)

These inputs are used for work number input signal, offset amount input signal and work coordinate system shift signal.

External Data Input Signal							
ED7	ED6	ED5	ED4	ED3	ED2	ED1	ED0
ED15	ED14	ED13	ED12	ED11	ED10	ED9	ED8
Sign							

(b) External data selection (EDSA to ESDO)

Inputted data can be selected by the external data.

Table 20.10

	External Data Input Selection			
	EDSD	EDSC	EDSB	EDSA
External Work No. Designation	0	0	0	1
External Tool Compensation (H)	0	0	1	0
External Tool Compensation (D)	0	0	1	1
External Coordinate Shift	0	1	0	0

1: Closed, 0: Open

(c) External data axis selection (EDAS0 to EDAS2)

This signal is used for specifying the axis for external data and given in three bits.

Table 20.11

	External Data Axis Selection		
	EDAS2	EDAS1	EDAS0
X-axis	ABS/INC	0	0
Y-axis	ABS/INC	0	1
Z-axis	ABS/INC	1	0
4th axis	ABS/INC	1	1

ABS=1, INC=0

All external coordinate system shifts are of INC.

(d) External data selection strobe (EDCL)

External data input starts when this signal rises up.

(3) Output signal for external data input

When input data described in (a) to (d) are inputted and stored in the internal memory, it is indicated by outputting completion signal (EREND or ESEND).

(4) Time Chart of Inputting External Data

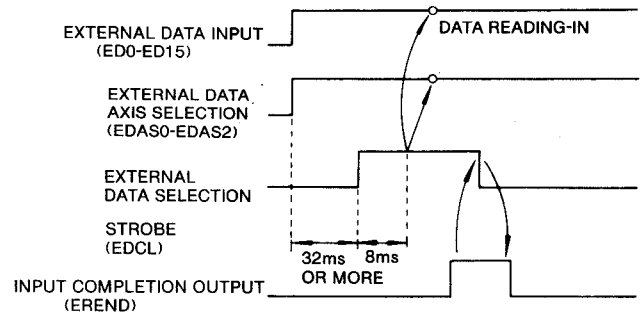

Fig. 20.11

For external work number input, when it is inputted ESEND instead EREND is given as input completion output.

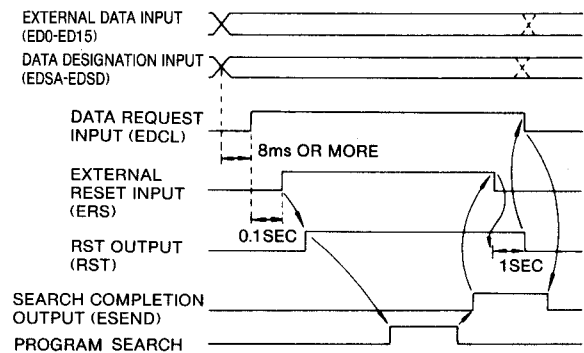

Fig. 20.12

(5) List of External Data Input/Output

(a) Inputs (24) (See Table 20.12.)

Table 20.12

External Data Input/Output	Input Strobe	Axis Selection			Data Selection				External Data																
		ED AS1	ED AS2	ED AS3	ED SD	ED SC	ED SB	ED SA	ED 15	ED 14	ED 13	ED 12	ED 11	ED 10	ED 9	ED 8	ED 7	ED 6	ED 5	ED 4	ED 3	ED 2	ED 1	ED 0	
External Work No. Designation	—	—	—	—	0	0	0	1	WNO1000				WND100				WND10				WND1				
External Tool Compensation (H)	—	ABS/INC	—	—	0	0	1	0	SIGN	±7999 (BCD) OR															
External Tool Compensation (D)	—	ABS/INC	—	—	0	0	1	1		SIGN	±32767 (BINARY)														
External Coordinate System shift	—	—	—	—	0	1	0	0	SIGN		Selected by parameter. †														

† Parameter selection #6040 D7 1=BCD, 0=BINARY

BCD:
4 digit
1-9999

20.2.28 EXTERNAL DATA INPUT (ED0 THROUGH ED15, EDSA THROUGH EDSB, EDSA0 THROUGH EDSA2, EDCL, EREND AND ESEND) INPUTS/OUTPUTS (Cont'd)

(b) Outputs (2)

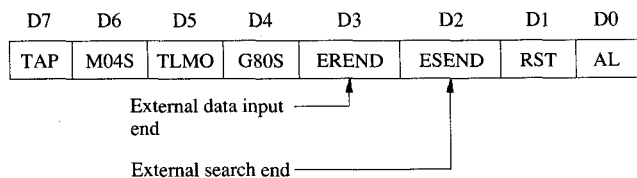

SUPPLEMENTARY EXPLANATION

(1) External Work No. Designation

- (a) Input-completion output is not given when work number other than 0 to 9999 is designated or work number is not found. In this case, alarm is not given.
- (b) Work number input is permitted by external reset operation or at the time of execution of M02 or M30. After reset operation, new work number is effective.

(2) External Tool Offset

- (a) The offset number to be modified is selected by program
- (b) Type of modification is selected by external input as follows.
 - EDAS2=0—Externally inputted data is added to the stored value.
 - EDAS2=1—Externally inputted data is replaced with the stored data.
- (c) External tool number address is selected by two bits of external data select (EDSA-EDSB) as follows.
 - EDSA="0," EDASB="1"—H For tool length offset
 - EDSA="1," EDASB="1"—D for tool diameter offset
- (d) If tool offset number is not selected (H is set at 00 or D is set at 00), input-completion signal is given without changing any offset value.
- (e) The offset value changed by external input is effective with the block including tool length offset (G43, G44) and tool diameter offset (G41, G42) command. Tool position offset A (G45 to G48) is effective with the next block including the command (G45 to G48).
- (f) Axis selection input EDAS0, EDAS1 is not required for external tool offset. If designated, the input is ignored.
- (g) The offset amount commanded by external tool offset input is equivalent to the amount entered by MDI key.

(3) External Work Coordinate System

- (a) The shift value commanded by external work coordinate system shift is equivalent to the value entered by MDI key.
- (b) The shift value commanded by external work coordinate system shift input is added to the stored shift value (G54 to G59).

20.2.29 CANNED CYCLE SPINDLE CONTROL (FMF, FFIN, SSP, SRV, OS, TAP)

FMF — Canned cycle auxiliary signal reading-in

FFIN — Canned cycle auxiliary completion signal

SSP — Spindle stop

SRV — Spindle reverse

TAP — Tapping

Canned cycles can be performed by G74, G84, G86 to G88 commands. At G74 and G84 commands, FMF and SRV are given, and at G86 to G88 commands, FMF and SSP or stop the spindle.

FMF is turned off when FFIN is sent back to the control at completion of spindle reverse or stop.

Turn off signal FFIN when FMF is turned off.

When FFIN signal is stopped, the tool retraction from tapped hole is started. Signals SRV from tapped hole is started. Signals SRV and SSP will be turned off when the tool leaves the tapped hole. Accordingly, reverse the spindle to the forward run. Motion by G74 and G84 commands, TAP signal is outputted indicating TAPPING operation. The TAP signal is used to check to see if the spindle runs at the beginning of tapping.

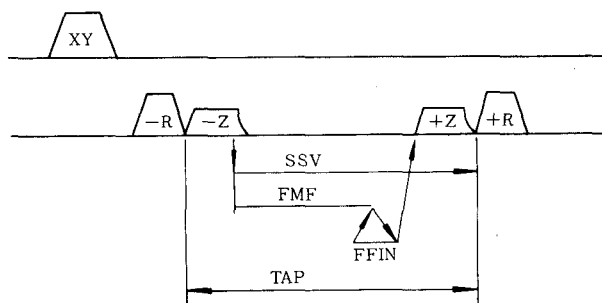

Fig. 20.13 Time Chart of G74, G84

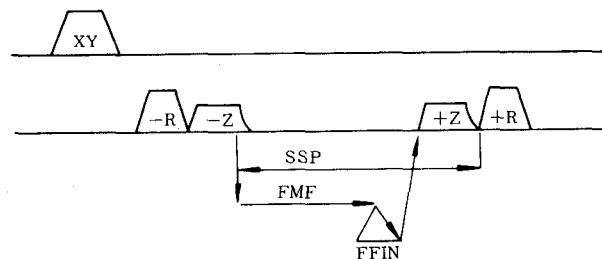

Fig. 20.14 Time Chart of G86 through G88

Setting parameter #6018 (D4) to "0" selects signals (M03, M04, M05, M19, MF, FIN) instead of canned cycles (FMF, SSP, SRV) in order to perform canned cycles. In spindle reverse by G74 and G84, spindle can be stopped by setting parameter #6018 (D5) to "1."

Time chart is as follows.

Parameter #6018 D5=0 M03 ↔ M04
 D5=0 M03 ↔ M05 ↔ M04

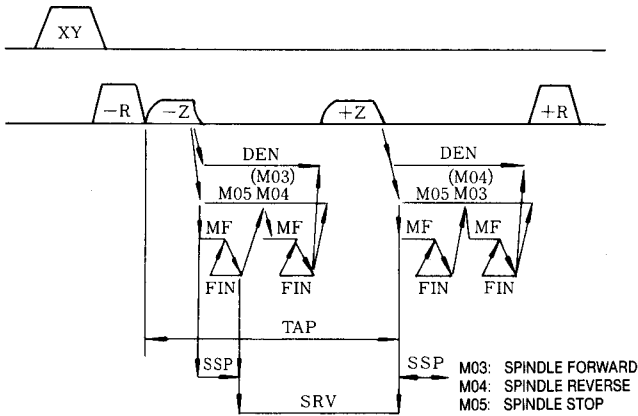

Fig. 20.15 Time Chart of G74, G84

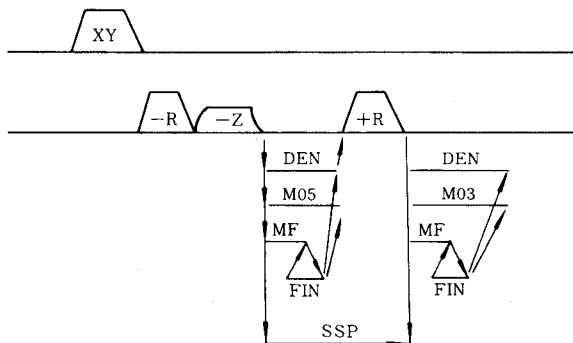
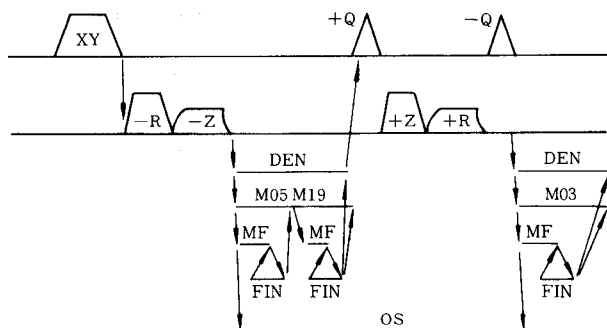

Fig. 20.16 Time chart of G86 through G88



M19: ORIENT SPINDLE STOP
 (SPINDLE STOP AT SPECIFIED POSITION)

Fig. 20.17 Time Chart of G76

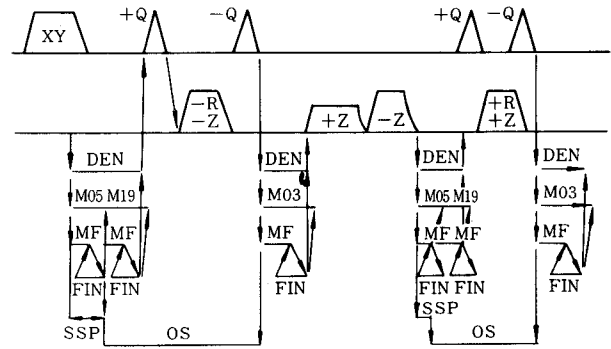

Fig. 20.18 Time Chart of G77

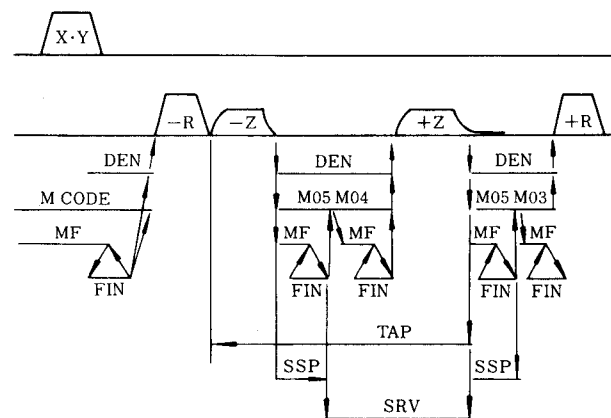

Fig. 20.19 Time Chart of M Command during Canned Cycle ON

Canned Cycle ON Signal (G80S)

When canned cycle starts, its output is given. The canned cycle signal is stopped in canned cycle cancel block.

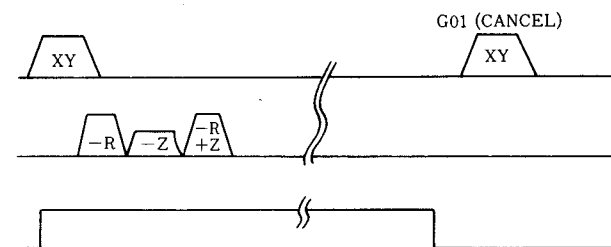
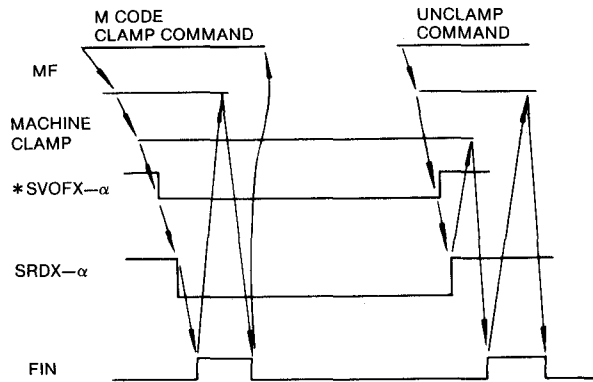

Fig. 20.20 Canned Cycle ON Signal (G80S)

20.2.30 SERVO OFF SIGNAL (*SVOFX, *SVOFY, *SVOFZ, *SVOF α .)

This signal is used for cutting with the axis mechanically clamped. When the signal *SVOFX to α contacts are open, servo lock for α -axis is released. To clamp the machine, use M-function. Shown below is the time chart of servo off signal, machine clamp, auxiliary function and servo ready (SRDX to SRD α). Output clamp command after positioning signal (DEN) is given.



*Activating at LOW.
(Normally closed contacts.)

Fig. 20.21 Time Chart of Servo Off Signal

When the signal *SVOFX to α contacts are open, parameter #6064 can select execution or no execution of the follow-up process.

#6064, D0 = 1: X-axis follow-up process

#6064, D0 = 0: X-axis no follow-up process

Other axes can be selected by D1, D2 and D3 in succession. When executing the follow-up process, shift the current NC value until the error counter becomes 0, as if there has been a command corresponding to the machine motion.

In this case, even when the SVOFF signal is restored to close, the machine remains at the shifted position, and it moves to the correct position when a subsequent absolute command is given, because the current NC value has been shifted from the machine position.

Conversely, when no follow-up process is executed, the servo setting remains in the error counter. Then the machine moves to cancel the setting when the SERVO OFF signal is restored to close.

20.2.31 EXTERNAL DECELERATION (*+EDX, *-EDX TO *+EDa, *-ED α)

This signal permits the maximum effective stroke of the machine in the control and controls the high-speed operation. When the external deceleration signal corresponding to axis is turned on during rapid traverse or manual jog operation, if the axis direction coincides with commanded direction, the machine decelerates to the speed set by parameter #6340.

If not, it does not decelerate. In this case, other axes will not have any effect.

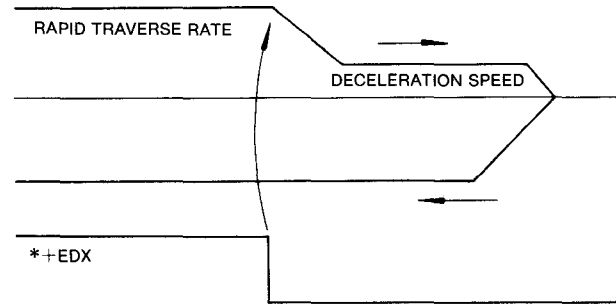

*+EDX

Fig. 20.22

Cutting feed function (*+EDX to *+ED β) enable or disable can be set by parameter #6012 to #6013.

				D3	D2	D1	D0	D3
#6012				α	Z	Y	X	

External deceleration in plus direction
Enable =1, Disable =0

#6013				α	Z	Y	X
-------	--	--	--	----------	---	---	---

External deceleration in minus direction
Enable =1, Disable =0

When the axis in moving meets the deceleration conditions, feedrate parameter #6341.

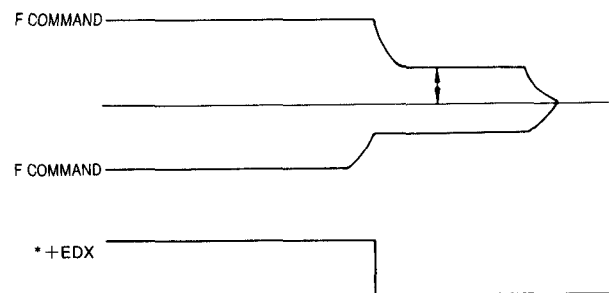

Fig. 20.23

When command speed is smaller than deceleration speed, command speed takes priority.

20.2.32 F1-DIGIT COMMAND (F1)

- (1) With a digit of 1 through 9 after an address F, feedrates corresponding to these digits can be selectively commanded.

F Command	F1-digit Speed Setting No.
F1	#6561
F2	#6562
F3	#6563
F4	#6564
F5	#6565
F6	#6566
F7	#6567
F8	#6568
F9	#6569

Setting value "1" = 0.1 mm/min

- (2) When F 1-digit switch is turned on, the feedrate specified by F 1-digit is increased or decreased by rotating manual pulse generator. Feedrate increase or decrease value per 1 pulse is set by parameter (F 1-digit multiplication) as shown in the table below.

F Command	F 1-digit Multiplication Parameter No.
F1	#6141
F2	#6142
F3	#6143
F4	#6144
F5	#6145
F6	#6146
F7	#6147
F8	#6148
F9	#6149

Setting value "1" = 0.1 mm/min pulse

In result, the contents of F1-digit speed setting are changed.

(3) Maximum Speed Limit

Maximum feedrate specified by F 1-digit can be set by parameters listed in the table below. The value exceeding usual maximum feedrate specified by parameter #6228 will be limited by parameter #6228 value.

Parameter No.	Function
#6226	Max feedrate by F1 to F4
#6227	Max feedrate by F5 to F9

Notes :

1. With this function, 1 to 9 mm/min cannot be commanded by usual F-function. Command exceeding 10 mm/min can be made.
2. Programming F0 will be indicated by alarm "030."
3. While Dry Run switch is on, dry run speed will take priority.
4. Feedrate override function will not work on F 1-digit command.
5. Stored feedrate will be kept after turning off power.

20.2.33 INTERFACE INPUT SIGNALS U10-U115, U00-U015 (#1000 THROUGH #1015, #1032)

- (1) When one of system variable #1000 through #1015 is specified to the right-hand of an operational expression, the on/off state of each of macro-program-dedicated 16-point input signal is read. The relationships between the input signals and the system variables are shown below.

#1007	#1006	#1005	#1004	#1003	#1002	#1001	#1000
UI7 2 ⁷	UI6 2 ⁶	UI5 2 ⁵	UI4 2 ⁴	UI3 2 ³	UI2 2 ²	UI1 2 ¹	UI0 2 ⁰
#1015	#1014	#1013	#1012	#1011	#1010	#1009	#1008
UI15 2 ¹⁵	UI14 2 ¹⁴	UI13 2 ¹³	UI12 2 ¹²	UI11 2 ¹¹	UI10 2 ¹⁰	UI9 2 ⁹	UI8 2 ⁸

Variable Value	Input Signal
1	Contact Closed
0	Contact Open

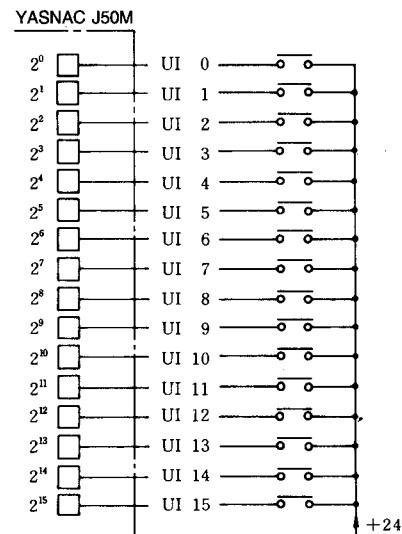

Each read variable is 1.0 or 0.0 when the associated contact is "closed" or "open" respectively, regardless of the unit system of the machine.

- (2) When system variable #1032 is designated, the input signals (UI0 through UI15) that consist of 16 points (16 bits) are collectively read as a decimal positive value.

$$\#1032 = \sum_{I=0}^{15} [1000 + I] * 2^I$$

Sample Program

- (a) 1F [#1015 EQ0] GOTO 100;

Bit 2¹⁵ (UI15) is read and, if it is "0," a branch is made to sequence number N100.

20.2.33 INTERFACE INPUT SIGNALS UI0-UI15, UO0-UO15 (#1000 THROUGH #1015, #1032) (Cont'd)

(b) #130 = #1032 AND 255

Bit 2⁰ through 2⁷ (UI0 through UI7) are collectively read to be stored in common variable #130 as a decimal positive value.

System variables #1000 through #1032 cannot be placed to the left-hand of operational expressions.

20. 2. 34 INTERFACE OUTPUT SIGNALS (#1100 THROUGH #1115, #1132) †

(1) When one of system variable #1100 through #1115 is specified to the left-hand of an operational expression, an on or off signal can be sent to each of user-macro-dedicated 16-point output signals.

The relationships between the output signals and the system variables are as shown below.

#1107	#1106	#1105	#1104	#1103	#1102	#1101	#1100
UO7	UO6	UO5	UO4	UO3	UO2	UO1	UO0
2 ⁷	2 ⁶	2 ⁵	2 ⁴	2 ³	2 ²	2 ¹	2 ⁰
#1115	#1114	#1113	#1112	#1111	#1110	#1109	#1108
UO15	UO14	UO13	UO12	UO11	UO10	UO9	UO8
2 ¹⁵	2 ¹⁴	2 ¹³	2 ¹²	2 ¹¹	2 ¹⁰	2 ⁹	2 ⁸

Variable Value	Output Signal
1	Contact Closed
0	Contact Open

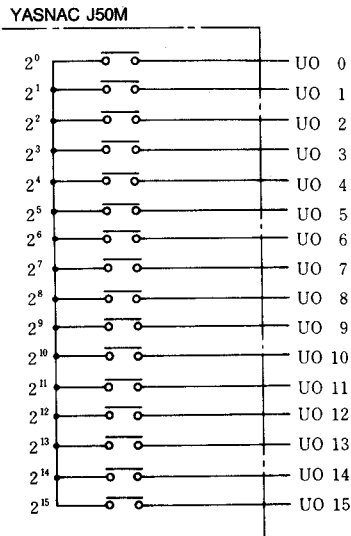

When 1.0 or 0.0 are substituted in any of #1100 through #1115, the associated output contact is output in the “closed” or “open” state.

(2) When system variable #1132 is specified, the output signals (UO0 through UO15) that consist of 16 points (16 bits) are collectively this time, the decimal positive value substituted in #1132 is output in the form of binary 16-bit value.

$$\#1132 = \sum_{I=0}^{15} [1000 + I] * 2^I$$

(3) With system variables #1100 through #1132, the value sent last is retained. Hence, when one of them is written to the right-hand of an operational expression, its value is read.

(4) Considerations

When any values other than 1.0 or 0.0 are substituted into one of #1100 through #1115, the values are handled as follows: “Blank” is assumed to be “0.” Values other than “blank” and 0 are assumed to be “1.”

Sample Program

(a) #1107 = #10; (#10 = 1.5)

The output signal of bit 2⁷(UO7) is outputted in the contact (closed) state.

(b) #1132 = (#1132 AND 240) OR (#8;)

The output signal of bits 2⁴ through 2⁷ (UO4 through UO7) are outputted without change and contents of local variable #8 are outputted to the output signals of bits 2⁰ through 2³ (UO0 through UO3).

(Decimal 240) = 11110000

20.2.35 SKIP INPUT

If SKIP input is closed during the execution of move command by G31 in the automatic operation mode, the control immediately stops the movement and stores the coordinate value where SKIP input changed from open to close. At this point, the block of G31 command is regarded to have been completed, and the following block is taken up.

The coordinate value of the skip position is stored in the following setting numbers.

The initial point coordinate value of the block of G31 command is stored for the axis not being specified.

- #6552 — X-axis coordinate value
- #6553 — Y-axis coordinate value
- #6553 — Z-axis coordinate value
- #6553 — α-axis coordinate value

NOTE

1. The block of G31 command moves in the same way as G01. If parameter (#6019, D4) is set to "1," the feedrate which is not specified in the part program but is set to parameter #6232 is provided.
2. If SKIP input is not closed after the completion of the block of G31 command, the following operation takes place:
 - a. When setting #6004, D0 is set to "1," the following block is executed.
 - b. When setting #6004, D0 is set to "0," the alarm state (alarm code "087") is generated.
3. SKIP signal is effective, when turned off, by setting parameter #6024, D4.
4. There is a parameter for determining enable or disable for the skip input control circuit. To enable the skip function, set parameter #6063, D1 to "1."

20.2.36 PROGRAM INTERRUPT (PINT) INPUT

This input is used to jump an NC program to be executed by the external input to a given location during the execution of a part program in the automatic operation mode.

When PINT input changes from open to close while the control is executing the block between M91 and M90 commands, it immediately discontinues this block and starts the execution of the part program of the program number (P) specified in the block of M91.

Note

If PINT input changes from open to close when the control is at standstill after the execution of a block between M91 and M90 commands on a single block basis, the execution of the part program specified in P is started at the time the automatic activation is performed.

20.2.37 DISPLAY RESET (DRS) INPUT

These inputs set the external 3-axis current value display (EXTERNAL DISPLAY) on the CRT operator's panel to "0." They are used with Handle axis selection input.

DRS	Closed	HX	Closed	External display X-axis reset
			Open	—
		HY	Closed	External display Y-axis reset
			Open	—
		HZ	Closed	External display Z-axis reset
			Open	—
		H α	Closed	External display α -axis reset
			Open	—

20.2.38 TOOL LENGTH OFFSET (TLMI, RET, TLM O) INPUTS/OUTPUTS

Opening TLMI contacts stores the Z-axis current value in the control as home position. In this case, tool length mode indicating TLMO is outputted. Closing RET after moving Z-axis to the measured point stores the move distance of Z-axis from the home position in the offset memory.

Opening TLMI contact again cancels TLM mode and stops TLMO output.

20.2.39 AXIS INTERLOCK (ITX, ITY, ITZ, IT α) INPUTS

Axis interlock is provided with each axis for inhibiting axis motion.

- (1) When axis interlock contact is opened during motion, the axis is coasted to stop. Closing the interlock will resume the remaining operation interrupted by opening the interlock contact.

When the remaining operation is completed, operation will advance to the next block.

- (2) For simultaneous controlled two axes or three axes in interpolation command, opening the axis interlock contact for any one axis of them stops interpolation and decelerates the axis to stop.

20.2.40 PLAYBACK (PLYBK) INPUT

To put the control in the Playback mode, close the playback input in the manual operation mode (HANDLE, STEP, JOG, RAPID). In the Playback mode, current value for each axis can be edited by PROGRAM function key. Usual manual operation is also permitted. Open the Playback input contact and usual manual operation mode is obtained.

20.2.41 S5-DIGIT COMMAND (SDA1 THROUGH SDA16, DAS, SGS0, GRL, GRH, GRA, GRB, M04S, SIN, SFIN) INPUTS/OUTPUTS

These signals are used to determine the speed of the spindle motor when the control is in the state of S command 5-Digit Non-Contact output or S Command 5-Digit Analog output.

GRA and GRB are used to enter the control state of the gear range between the spindle and the spindle motor to determine the spindle motor speed by the spindle speed specified in the part program.

SINV input inverts the polarity of the analog output at the time of S command 5-Digit Analog output.

While the polarity is inverted, SINV signal is output.

When M03 command is executed, M04S contact is opened. When M04 command is started, M04S contact is closed.

(1) S5-Digit Command 12-Bit Non-Contact Output

Binary code 12 bits (0 to 4095 = spindle motor speed) are output as follows by the spindle motor speed command and GR1 through GR4:

- ; The output when "GR1" input is closed. (Set the spindle motor maximum speed at gear range "GR1" to parameter #6271.)
- ; The output when "GR2" input is closed. (Set the spindle motor maximum speed at gear range "GR2" to parameter #6272.)
- ; The output when "GR3" input is closed. (Set the spindle motor maximum speed at gear range "GR3" to parameter #6273.)
- ; The output when "GR4" input is closed. (Set the spindle motor maximum speed at gear range "GR4" to parameter #6274.)

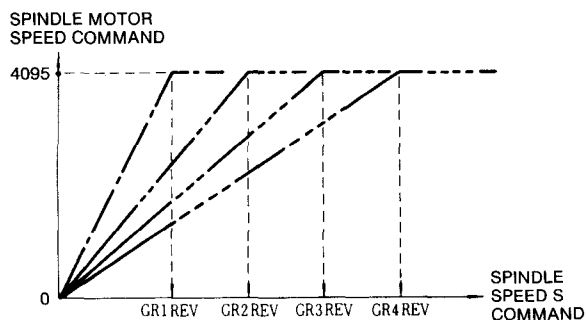

Fig. 20.24

(2) S5-Digit Command Analog (DAS, SGS0) Outputs

Analog voltages (-10 V to 0 V to +10 V) are output as follows by the spindle speed command, GR1 through GR4 inputs, and SINV input:

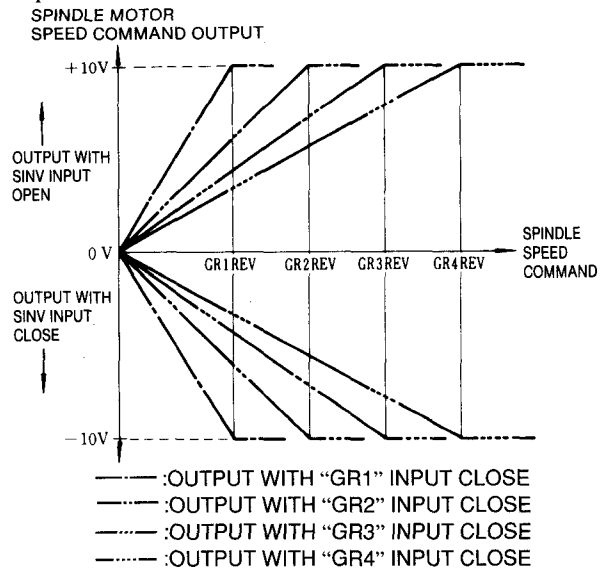

Fig. 20.25

(3) Time Chart of Analog Voltage Output, SINV Input, and SINVA Output for Spindle Motor Speed

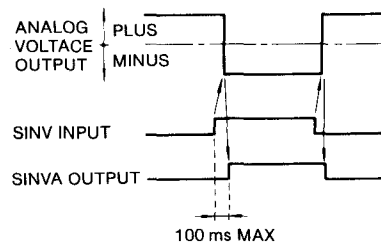

Fig. 20.26

(4) Spindle Maximum/Minimum Speed Clamp

The spindle maximum/minimum speed at each gear range may be set using the following parameters:

Table 20.13

Parameter		Fig. No.
#6266	Spindle maximum speed when "GR1" input is closed.	V
#6267	Spindle maximum speed when "GR2" input is closed.	VI
#6268	Spindle maximum speed when "GR1" input is closed.	VI
#6269	Spindle maximum speed when "GR3" input is closed.	VIII
#6276	Spindle maximum speed when "GR4" input is closed.	I
#6277	Spindle minimum speed when "GR1" input is closed.	II
#6278	Spindle minimum speed when "GR3" input is closed.	III
#6279	Spindle minimum speed when "GR4" input is closed.	IV

The following diagram shows an example of the S5-digit analog outputs when the spindle maximum/minimum speeds are clamped by these parameters:

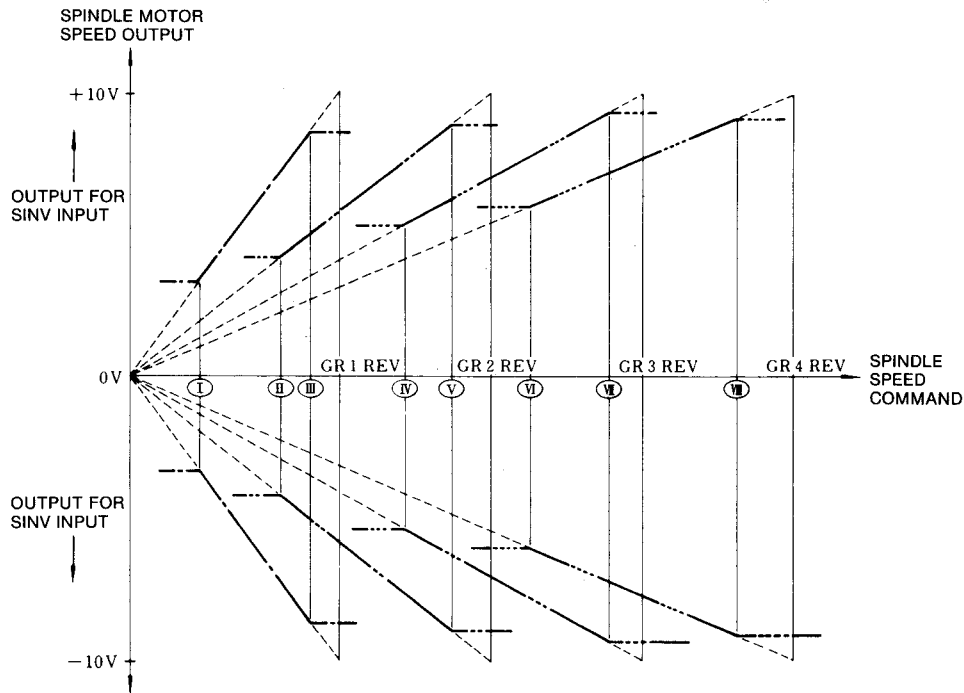

Fig. 20.27

Notes:

1. The spindle motor speed command output is obtained from the following relation:

$$\frac{(\text{Spindle speed command}) \times (4095 \text{ or } 10 \text{ V})}{(4095 \text{ or } 10 \text{ V output speed in spindle gear range determined by GR 1 through GR4 inputs: parameters \#6271 through \#6274.)}$$

2. With the spindle motor speed motor analog output, the polarity may be inverted by processing M03 (spindle forward rotation) or M04 (spindle reverse rotation) within the control by using parameter SDASGN1 or SDASGN2 (#6006, D6 or D7).

#6006, D6	#6006, D7	M03 Output	M04 Output
0	0	+	+
1	0	-	-
0	1	+	+
1	1	-	-

1: Closed, 0: Open

When SINV input is closed, the above polarities are inverted.

26.2.42 GEAR SELECTION COMMAND INPUT/OUTPUT (GRL, GRH, GRA, GRB, SF, SFIN) S4-DIGIT NON-CONTACT OUTPUT OR S5-DIGIT ANALOG OUTPUT

After executing S command, the control outputs SF signal and checks maximum gear speed designation (parameter #6266 to #6269) at the same time, and output gear selection command (GRL, GRH) corresponding to gear speed.

The control compares the outputted gear signal with current gear selection and sends back SFIN when they meet. If they are different, the control performs gear selection sequence. When the constant speed output is required for gear selection, GRO signal contact is closed. The control immediately outputs constant speed corresponds to GRO.

Input gear input signal (GRA, GRB) until gear selection is completed and send back spindle gear selection completion signal (SFIN) on completion of gear selection. The control outputs specified spindle speed command as non-contact or D/A output. Send back FIN signal when spindle speed agrees with command.

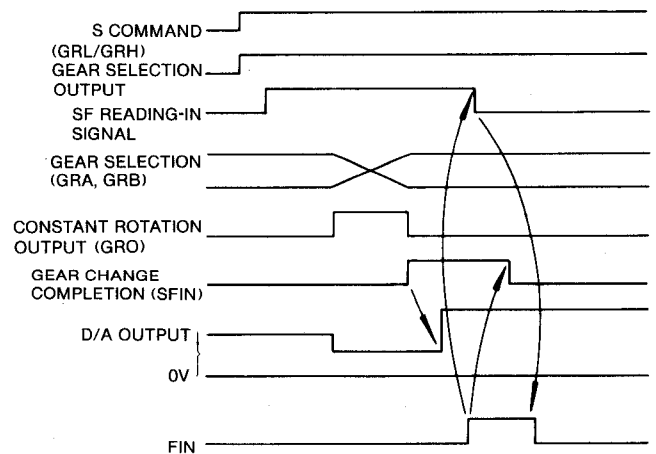

Fig. 20.28

20.2.42 GEAR SELECTION COMMAND INPUT/ OUTPUT (GRL, GRH, GRA, GRB, SF, SFIN) S4-DIGIT NON-CONTACT OUTPUT OR S5-DIGIT ANALOG OUTPUT (Cont'd)

Gesr selection output (GRL, GRH) and Gear selection input (GRA, GRB) select four types of gear range.

	GRB (H)	GRA (L)
GEAR 1 (CR1)	0	0
GEAR 2 (GR2)	0	1
GEAR 3 (CR3)	1	0
GEAR 4 (GR4)	1	1

1: Closed, 0: Open

20.2.43 GEAR SHIFT ON (GST) INPUT AND SPINDLE ORIENTATION (SOR) INPUT

These inputs are used to make the S5-digit command analog output and non-contact output provide the outputs other than the part program S command. When GST input is closed, the voltage set by parameter #6270 is outputted.

If SOR input is closed, the spindle speed set to parameter #6275 by the spindle gear range input and spindle motor speed command voltage corresponding to each gear are outputted.

Table 20. 14

GST Input	SOR Input	S5-digit Command Analog Voltage
0	0	Voltage corresponding to spindle speed command by NC program
0	1	Voltage corresponding to parameter #6275.
1	0	Voltage corresponding to oarameter #6270.
1	1	Voltage correspondong to parameter #6270.

1: Closed, 0: Open

Notes :

1. It is possible to make the analog output corresponding to GST, SOR inputs negative by the S5-digit analog output invert (SINV) input.
2. The period of time between the setting of GST and SOR inputs and the catching-up of the analog voltage value is shorter than 100 ms.

20.2.44 SINDLE SPEED REACHED (SAGR) INPUT

This input is used to inform, in the case of the S4-digit command, that the spindle speed has reached the specified value at the start of cutting at the execution of the part program in the automatic operation mode. At the start of cutting (when switching from a positioning command to a cutting command takes place), the control delays the time by the value specified in parameter #6224, make sure that SAGR input is closed, and starts cutting.

To perform the operation by SAGR input described above, set parameter #6006 D4 to "1."

If it is set to "0," SAGR input is ignored.

20.2.45 SPINDLE SPEED OVERRIDE (SPA, SPB, SPC, SPD, SPE) INPUTS

These inputs are used, in the case of the S5-digit analog command or non-contact output, to override the S command in a range of 50% to 120% at the execution of the part program in the automatic operation mode.

SPA Input	SPB Input	SPC Input	Override Corresponding S Command
1	1	1	50%
0	1	1	60%
0	1	0	70%
1	1	0	80%
1	0	0	90%
0	0	0	100%
0	0	1	110%
1	0	1	120%

1: Closed, 0: Open

It is possible to override the S command in a range of 10 to 200% by option.

Table 20. 15 Extension Type Spindle Override Input Setting and Override

SPA Input	SPB Input	SPC Input	SPD Input	SPE Input	Override Corresponding to S Command
0	0	0	1	0	10%
0	0	1	1	0	20%
0	1	1	1	0	30%
1	1	1	1	0	40%
1	1	1	0	0	50%
0	1	1	0	0	60%
0	1	0	0	0	70%
1	1	0	0	0	80%
1	0	0	0	0	90%
0	0	0	0	0	100%
0	0	1	0	0	110%
1	0	1	0	0	120%
1	0	1	1	0	130%
1	0	0	1	0	140%
1	1	0	1	0	150%
0	1	0	1	0	160%
0	1	0	1	1	170%
0	1	0	0	1	180%
0	0	0	0	1	190%
1	0	0	0	1	200%

1: Closed, 0: Open

20.2.46 S4-DIGIT COMMAND EXTERNAL OUTPUTS (SB1 THROUGH SB16) AND S5-DIGIT COMMAND EXTERNAL OUTPUTS (SDA1 THROUGH SDA16 OR SDI1 THROUGH SDI16)

These inputs and outputs are used, when the control is of S5-digit analog output or non-contact output to output the results of the operation by the S command in the part program to the outside and perform the actual S5-digit command 12-bit non-contact output or analog output according to the inputs from the outside.

(1) S5-Digit Command 12-Bit Non-Contact Output

Output of operation results to outside: SBL through SB12

(2) S5-Digit Command Analog Output

(a) Output of operation results to outside: SDA1 through SDA16.

Note: The input/output value is signed binary 16-bit.

The relationship with analog voltage is as follows.

-32768 to 0 to +32767
-10V to 0V to +10V

(b) Input from outside for outputting analog voltage to DAS. SGS0: SDI1 through SDI16.

The primary purpose of this function is to control the S5-digit analog output command or non-contact output command by the sequencer built in the control. This function should not be used for other purposes unless specifically required. Operation results are output selectively to the outside directly by NC or via outside inputs, depending on the setting of parameter #6032, D2. Set #6032, D2 to "1" to output via outside inputs.

20.2.47 EXTERNAL INPUT, VERIFY AND OUTPUT SIGNALS (EIN, EVER, EOUT, ECLM, IER, EDTS)

These signals are to command input, verification, and output of part programs to the part program memory by means of external signals.

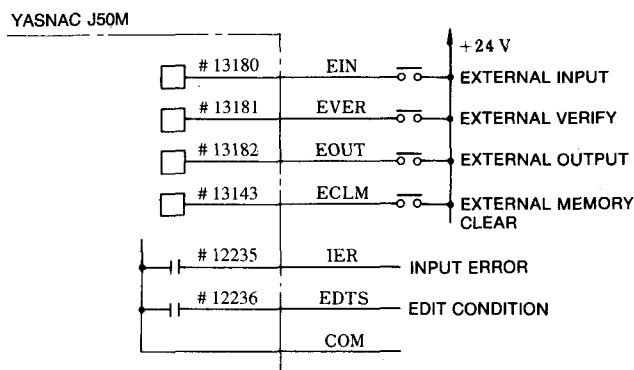

Fig. 20.28

(1) External Input (EIN) Input

If the EIN input is closed in label-skip state in the EDIT mode, the function will automatically switch to PROG. And it will start to store the part program in the part program memory through the input device (or interface) specified by parameter #6003. Set up the part program to be stored in the following format.

Registration of the program will be executed with the program number (O number) specified at the beginning of the part program. Program storage ends when the NC reads the EOR code (ER or %) at the end of the program.

Notes :

1. If O number has already been registered, store the program after erasing the existing program with the external memory clear (ECLM) input (see (4) this paragraph).
2. If parameter #6021 D6=1, execute storage after erasing the duplicate O number.

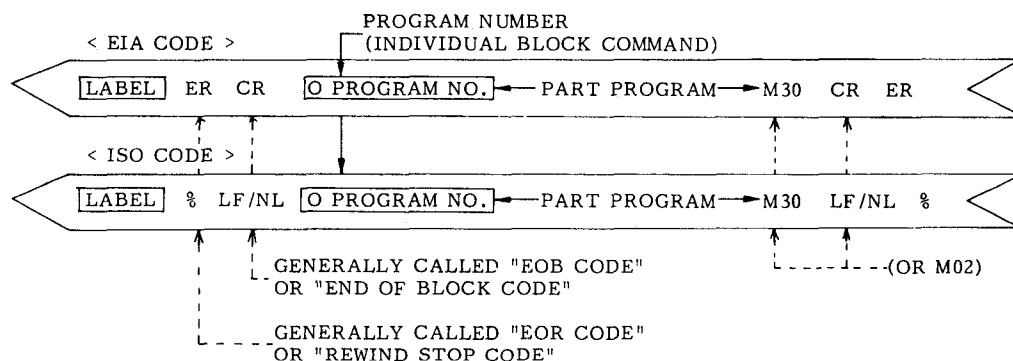

Fig. 20.29

20.2.47 EXTERNAL INPUT, VERIFY AND OUTPUT SIGNALS (EIN, EVER, EOUT, ECLM, IER, EDTS)

(2) External Verify (EVER) Input and Input Error (IER) Output

If the EVER input is closed in label-skip state in the EDIT mode, the function automatically changes over to PROG. And it will start to verify the external part program data and the part program data in the part program memory through the input device (or interface) specified by parameter #6003. Verification is performed on program with the specified O number.

When verifying a series of multiple part programs, execution does not stop at the end of each programs (M02 or M30). In this case, these data are continuously verified from the beginning EOR code (ER or %) to the ending EOR code.

If mismatch is found, the input error (IER) output signal is closed. This signal may be cleared and return to open by turning on the external reset (ERS) inputs.

(3) External Output (EOUT) Input

If the EOUT input is closed in label-skip state in the EDIT mode, the function automatically changes over to PROG. And it will output all part program data stored in the part program memory through the output interface specified by parameter #6003. However, specific part program specified by O number cannot be output.

(4) External Memory Clear (ECLM) Input

If the ECLM input is closed in label-skip state in the EDIT mode, the function automatically changes over to PROG. And it erases all part programs stored in the part program memory. However, specific part program specified by O number cannot be erased.

(5) Edit Condition (EDTS) Output

If input, verification, output and memory clear are being executed by turning EIN, EVER, EOUT and ECLM inputs on, this EDTS output signal closed. When execution is completed, this signal is opened again.

(6) Usage Example and The Time Chart

The following procedure is operating sequence during input (storage), verify and memory operation through an RS-232C interface using a DC code.

(a) Close EDIT mode.

(b) Close external reset (ERS) input.

The program pointer returns to the beginning of the part program currently selected, and label-skip function is effective.

(c) Close external memory clear (ECLM) input.

Function automatically changes over to PROG, and erase all part programs. The EDTS output is closed during erase condition and return to open when erasing is completed.

(d) Open EDTS signal to open external reset (ERS).

The label-skip function is effective.

(e) Close external input (EIN) signal. EDTS is closed.

i. The control unit turns on request sending signal RS of the RS-232C interface.

ii. If the NC unit becomes ready for sending, the combined equipment returns capable-of-sending signal CS to the NC unit.

iii. The NC unit sends control code DC1 through the sending data SD line.

iv. The combined equipment sends part program data to the NC unit through the receiving data RD line with DC1 as the trigger.

v. When the NC reads the EOR code (ER or %), control code DC3 is sent and at the same time request-sending signal RS is turned off.

vi. The combined equipment reads DC3 and, together with stopping sending of data, turns off capable-of sending signal CS.

(f) When the above part program storage is completed, the editing condition (EDTS) output is opened. If not in alarm state, the external reset (ERS) signal is closed. The label-skip function is effective.

(g) Close external verify (EVER) signal.

Verification between the part program data in NC and the external data is performed with the same operation as in (e)i. to vi, above. The EDTS output is closed during verify condition and returns to open when verification is completed.

(h) Close memory operation (MEM) mode if not in alarm state.

(i) Close external reset (ERS) signal.

The program pointer returns to the beginning of the part program which has been just verified. However, when batch verification is executed on a number of part programs, the program pointer returns to the beginning of the 1st part program. (When desiring to use a part program other than these, use "External Work No. Search" of the "External Data Input" function.

(j) Close cycle start (ST) input.

Automatic operation of the selected part program is performed.

(k) Automatic operation ends if the necessary FIN signal processing is executed to the M02 or M30 command of the last part program.

Fig. 12.30 shows the time chart of the various signals related above operation.

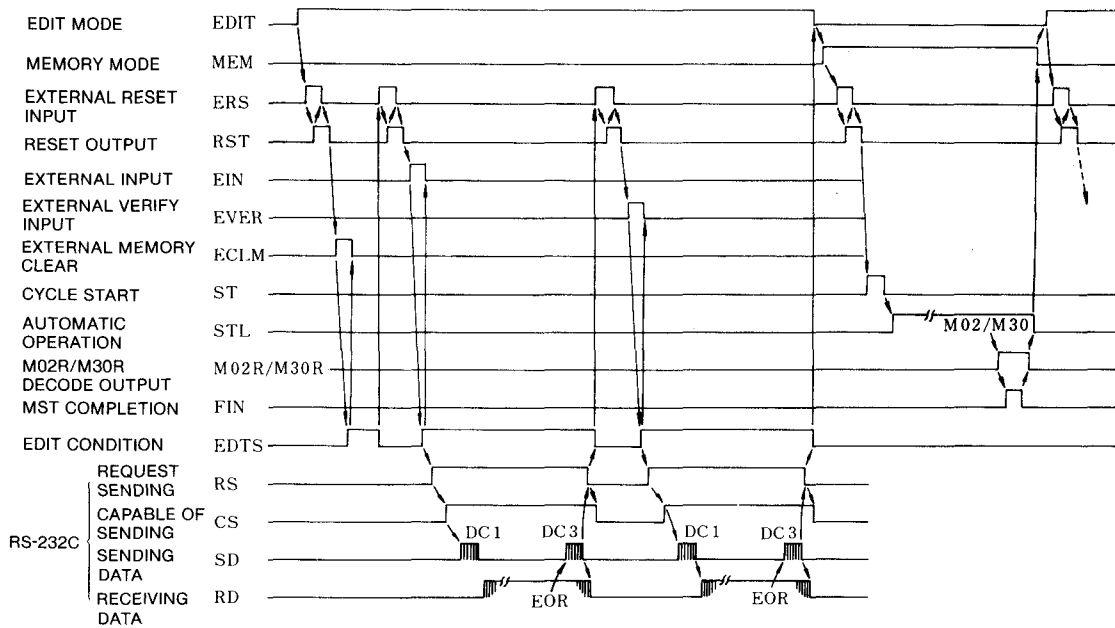

Fig. 20.30 Time Chart External Input and External Verify Input

(7) Precautions

- (a) For (6) operations, program number O 0000 cannot be used.
- (b) As a rule, part programs without a program number cannot be stored. However, the following cases are exceptions.
 - i. When setting #6207 = 0.
This normally be an input error. If O 0000 is displayed on the CRT screen, the program is stored in O 0000.
 - ii. When setting #6207 ≠ 0.
Stores part program normally with the numerical value set in #6207 as the program number.

(8) Alarm Status

- (a) If the part program memory capacity is exceeded when storing, "MEMORY OVER" is displayed on the CRT.
- (b) If the mismatch is found when program verifying, the input error (IER) output is closed. The alarm (ALM) output remains open.
- (c) When storing part program, command format checks are not executed. Format checks are executed during automatic operation and alarm status will be caused by error command.
- (d) To reset the alarm status and screen, close the external reset (ERS) input or depress the RESET key.
- (e) EDTS (Edit Condition) can be output not only during input, verify and output of part programs, but also during input, verify and output of offset parameter data.

20.2.48 TOOL LIFE CONTROL SIGNALS (TLCTN, TLSKP, TLRST, TL4-TL64, TLCHA, TLCHB)

Classify the tools into several groups and specify the tool life by use hours, number of works and use distance for each tool. Specify the tools in each group and when the specified life is reached, select and use the next tool in that same group.

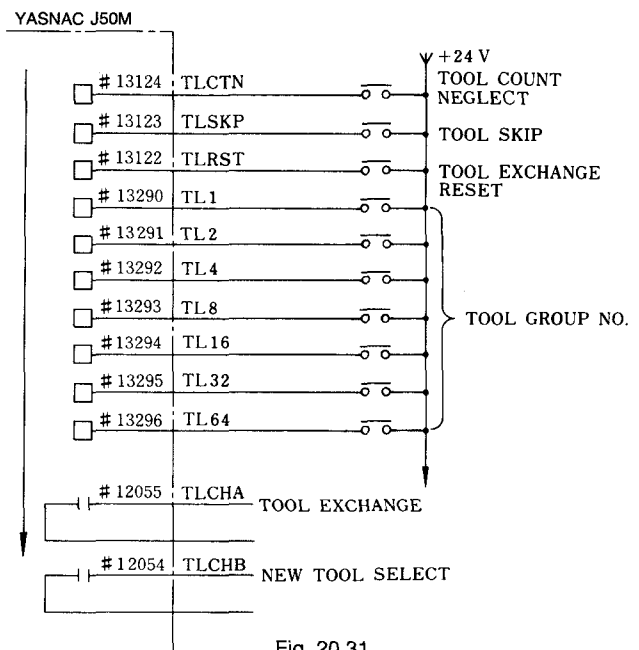

Fig. 20.31

20.2.48 TOOL LIFE CONTROL SIGNALS (TLCTN, TLSKP, TLRST, TL4-TL64, TLCHA, TLCHB) (Cont'd)

(1) Tool Life Neglect Input (TLCTN = #13124)

Tool life count stop in closing TLCTN signal during tool life control. Count function is applied only to the opening tool life neglect in the tool life set by time, frequency, or distance.

(2) Tool Skip Input (TLSKP = #13123)

This input is used when forcing change of a tool before the end of its life. Either (a) or (b) below before operation can be used by changing over parameter #6020 D7.

(a) Close tool skip input TLSKP after externally specifying the group number under the tool. With this operation, the group specified for skipping select the next tool at the next T code command.

(b) Set tool skip input close without specifying the group number. In this case, the current group number is specified.

(3) Tool Exchange Signal (TLCHA = #12055) and Tool Reset SignalL (TLRST = 13122)

The tool exchange signal (TLCHA) is closed when the life of all tools in one group is reached. In this case, the life count STS information is cleared by externally closing the tool exchange reset signal (TLRST).

NOTE

1. Although the TLCHA signal is output at the point where the end of tool life has been reached (when controlling life with time and distance), cutting continues.
2. The TLCHA signal is a signal that is output when the end of tool has been reached on all tool in one group. Even if tool change reset of a certain group is executed with the TLRST signal, the TLCHA signal remain closed, if there is even one other group in witch the end of tool life has been reached.
3. The TLRST signal is disregarded when it is closed during automatic operation (STL) or during feed hold (SPL).
4. When the TLRST signal is closed, the group in witch information is to be cleared is setting (#6024) or specified by the external input (TL1-TL64).
Selection of the alternative will be made with parameter #6020D5.

(4) New Tool Selection Signal (TLCHB = #12054)

When moving to a new tool within one group and, when the USED display of the new tool number is "0," the T code of that tool is output together with the new tool selection signal TLCHB.

Timing is shown in Fig. 20.32.

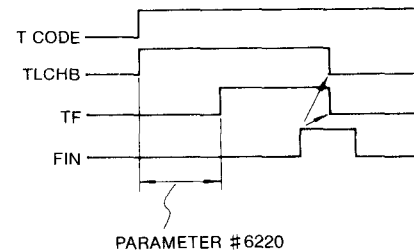

Fig. 20.32

(5) Tool Group Number Input (TL1 - TL64 = #13290 - #13296)

When inputting tool exchange reset signal TLRST and tool skip signal TLSKP, tool group number should be previously specified with tool number signal from TL1 to TL64. In this case, "the value of the tool group number to be commanded -1" is commanded with a binary number. During tool change reset, the tool group can be specified by setting (#6204) instead of using this value as input.

APPENDIX A DIMENSIONS in mm

(1) CNC Unit (Type JZNC-JRK00)

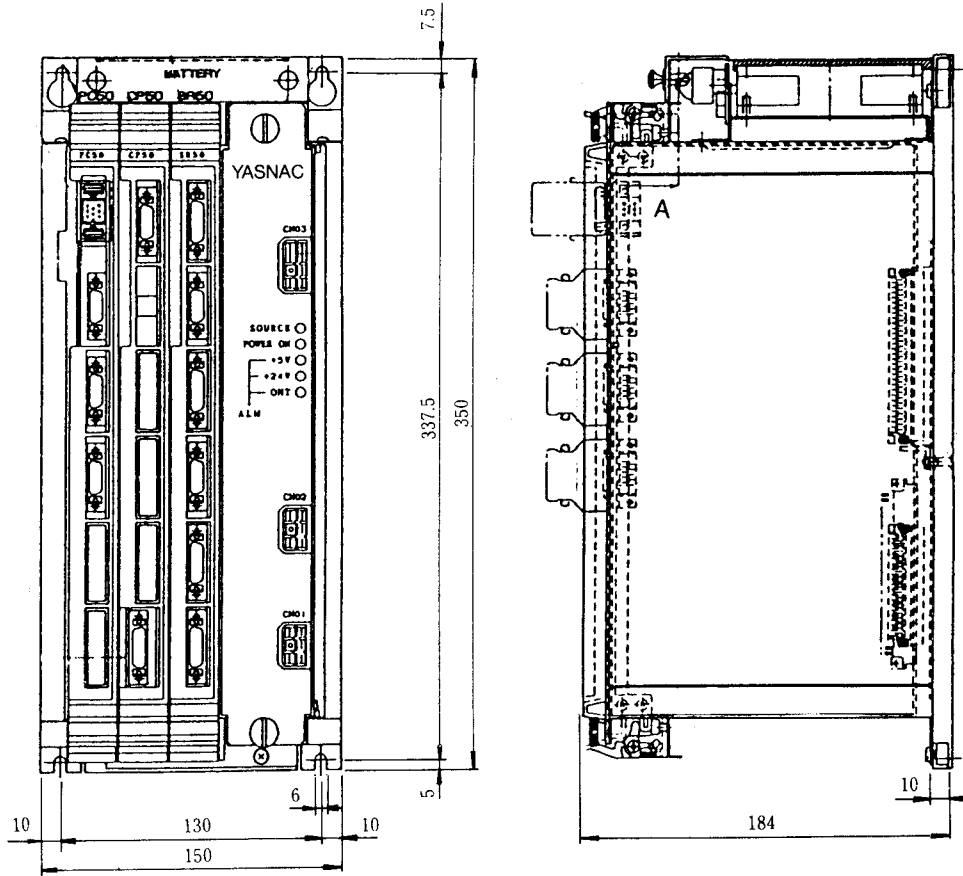

APPENDIX A DIMENSIONS in mm (Cont'd)

(2) Vertical Type CRT Operator's Panel (Type JZNC-JOP01)

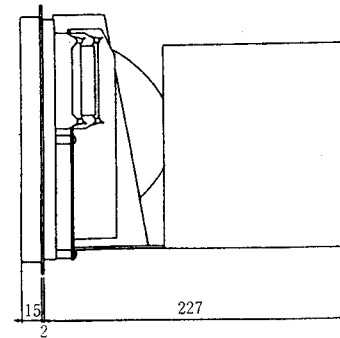
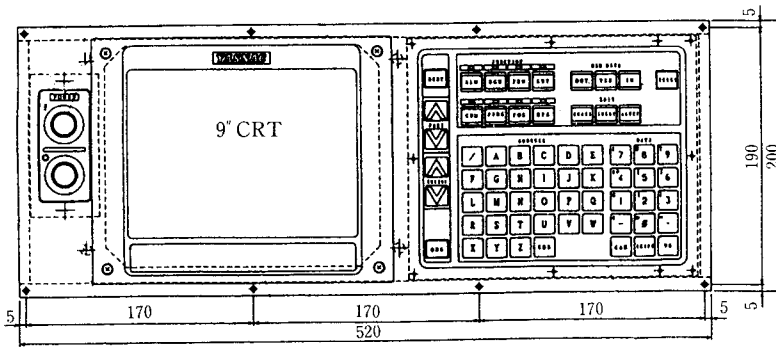
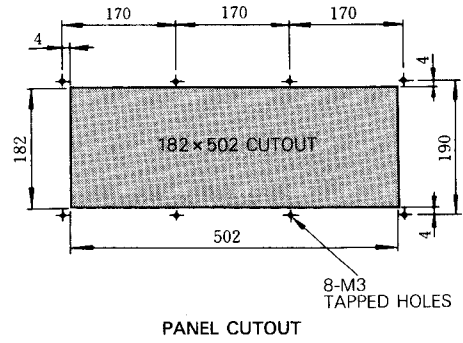
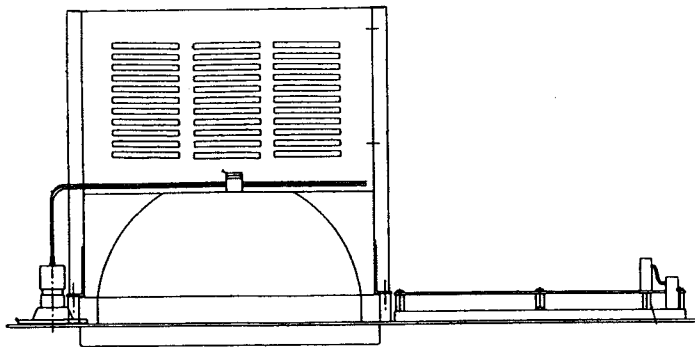

(3) Horizontal Type CRT Operator's Panel (Type JZNC-JOP02)

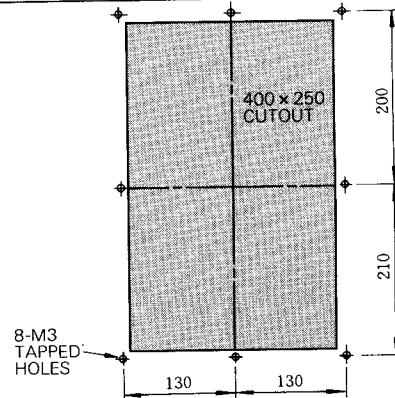
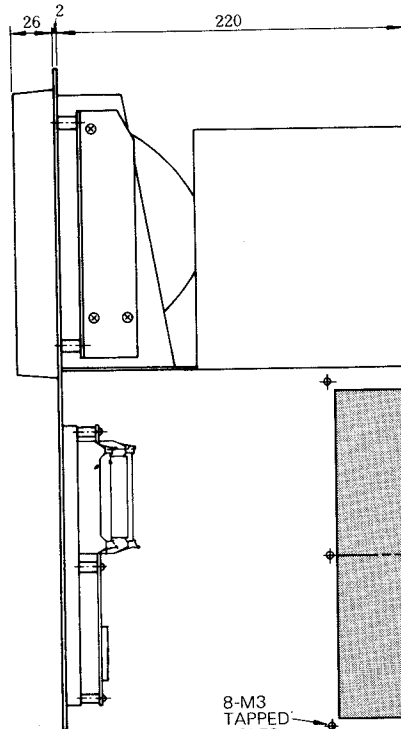
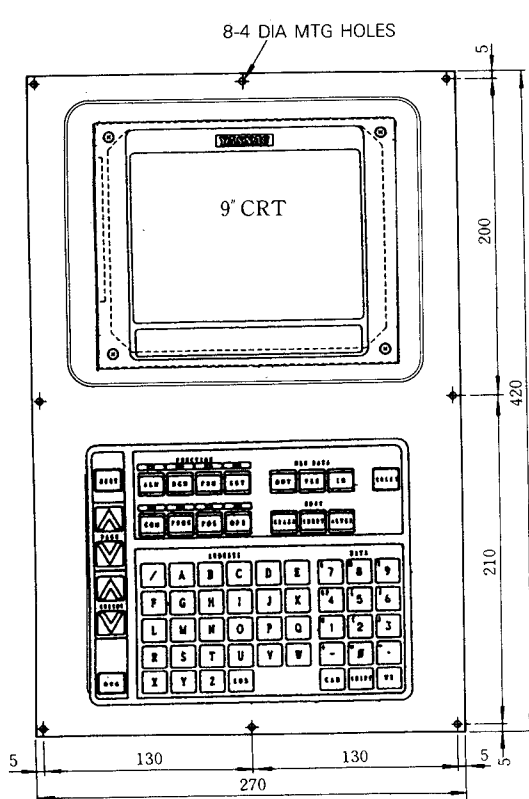

(4) Tape Reader Unit (Model 2801)

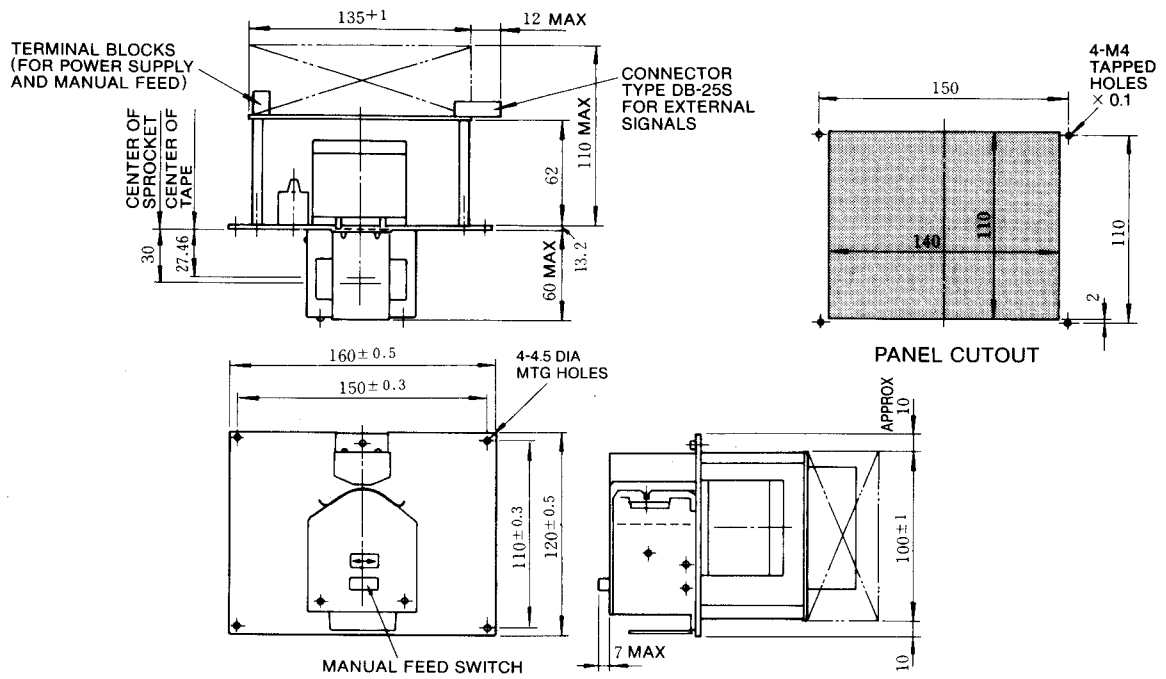

APPENDIX A DIMENSIONS in mm (Cont'd)

(5) Servo Units

(a) Types SGDB-05 to 15AD

Drawing No.: 9406975

(a) Types SGDB-20 to 30AD

Drawing No.: 9406975

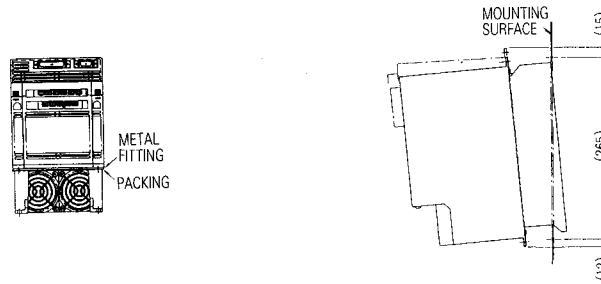
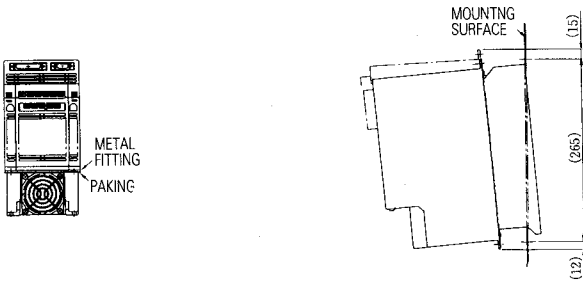
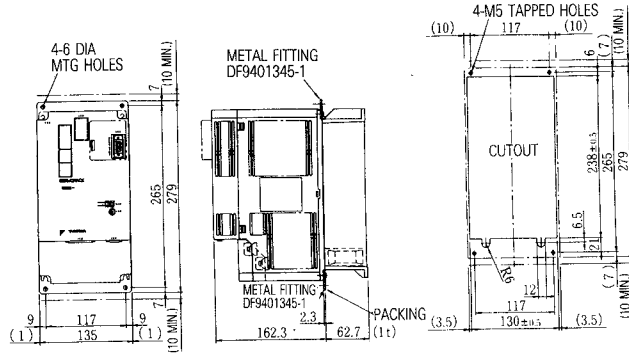
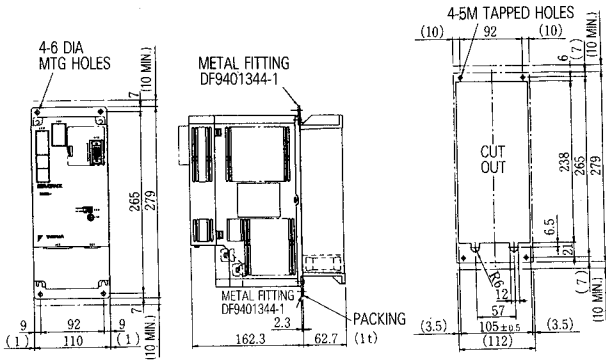

Approx mass: 5 kg

· Metal Fitting

Mount the metal fittings to the SERVOPACK.

Approx mass: 5 kg

· Packings A and B

After mounting the metal fittings, apply packings A and

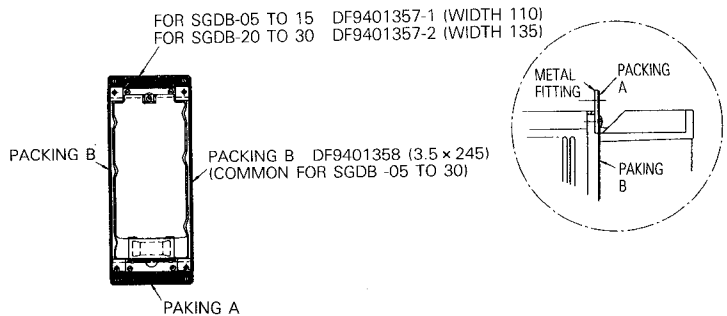
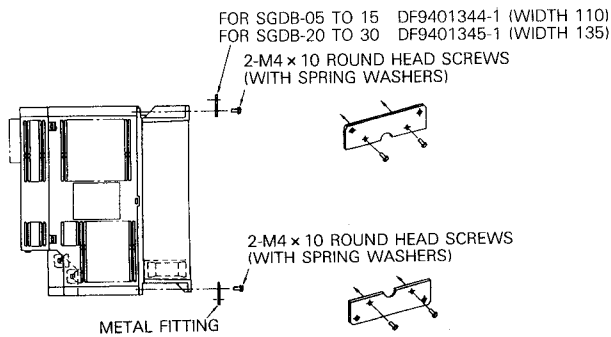

(6) Noise Filter (Types LF310, LF320, LF330)

Drawing No.: DE8302999

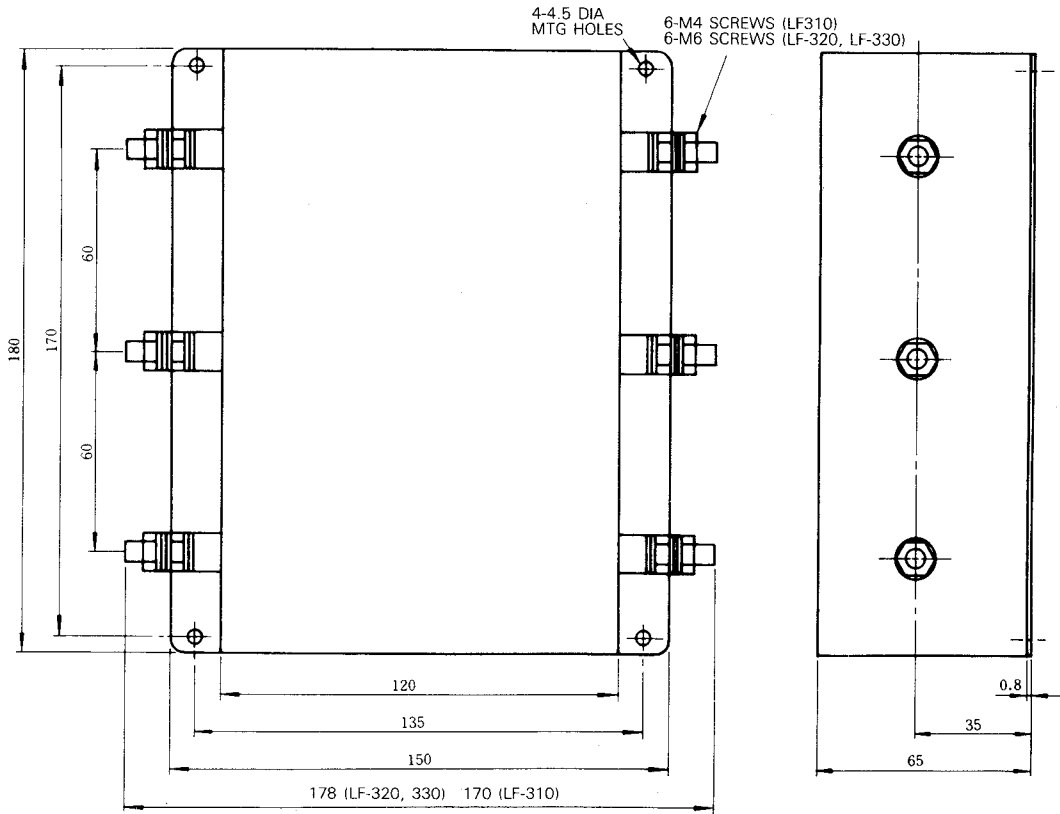

Approx. mass: 2.3 kg (LF-320, 330)
 1.9 kg (LF-310)

Noise Filter (Type LF340)
 Drawing No.: DE 8303000

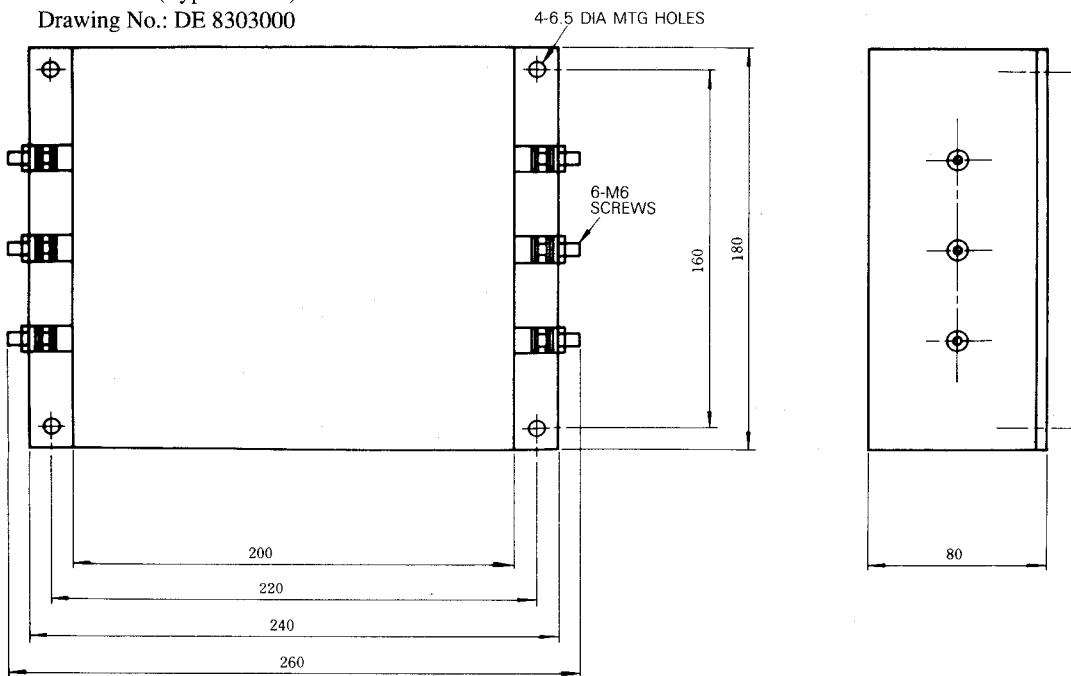

Approx. mass: 5 kg

APPENDIX A DIMENSIONS in mm (Cont'd)

(7) Power Supply Unit for Brake (Types LPDE-1H01, LPSE-2H01)

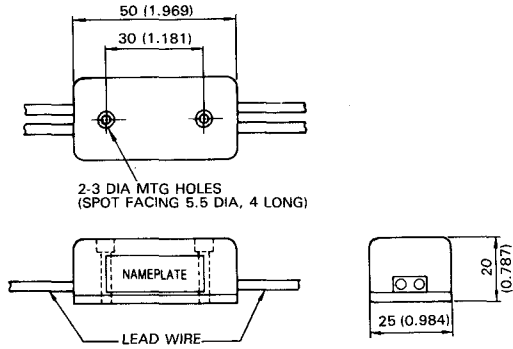

- Lead Length : 500 mm for each
- Lead Color

100VAC	200VAC	Brake Side
Blue, White	Yellow, White	Red, Black

- Ambient Temperature : 60°C max.

• Internal Circuit for 200VAC

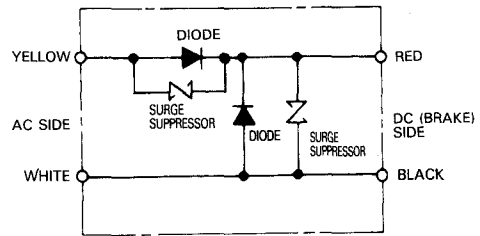

• Internal Circuit for 100VAC

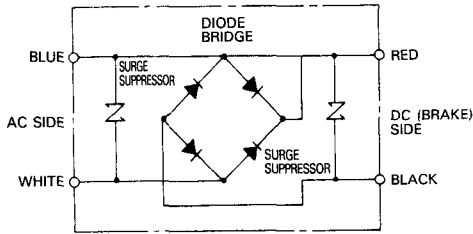

Note :

1. It is recommended that turning on or off of the brake power circuit be performed at the AC side.
For turning on or off at the DC side, provide the surge suppressor near the brake coils so as not to break the brake coils by surge voltage.

• Specifications

Type	Rectifier System	Frequency Hz	AC Input Voltage V	DC Output Voltage V	DC Output Current A	Approx Mass kg
LPDE-1H01	Single-phase half wave	50/60	180 to 230	90	1	0.1
LPSE-2H01	Single-phase full wave	50/60	90 to 120	90	1	0.1

(8) Manual Pulse Generator
(Type PREH-2E5T/100-M)

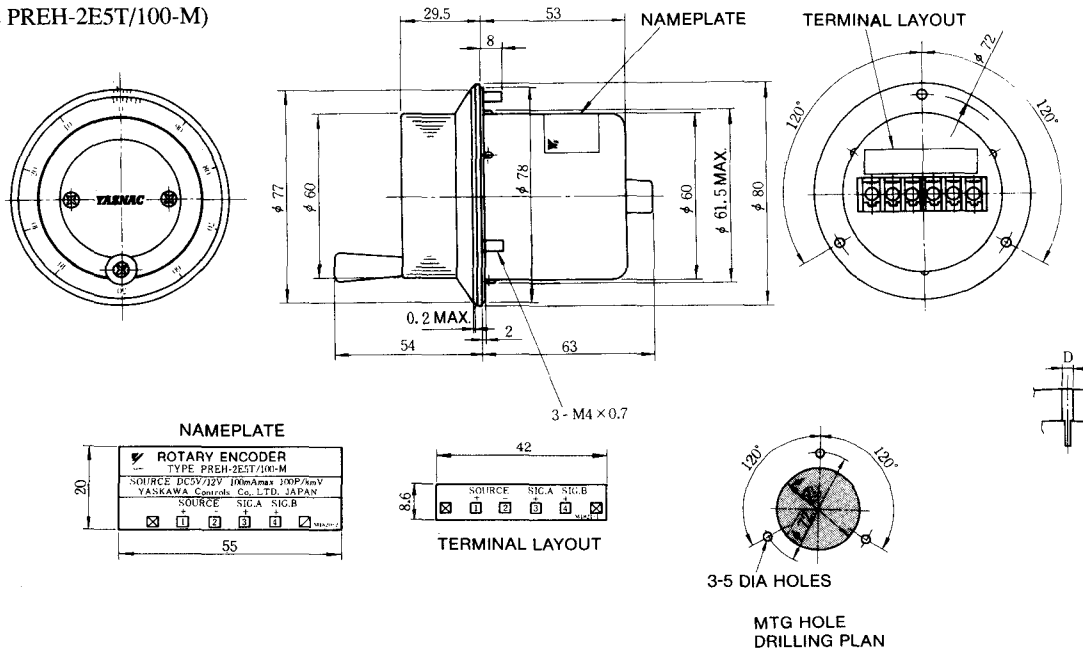

(9) Spindle Pulse Generator

(a) Types PC-1024ZL-4K-1, PC-1024ZL-6K-1

Drawing No.: DE6429539

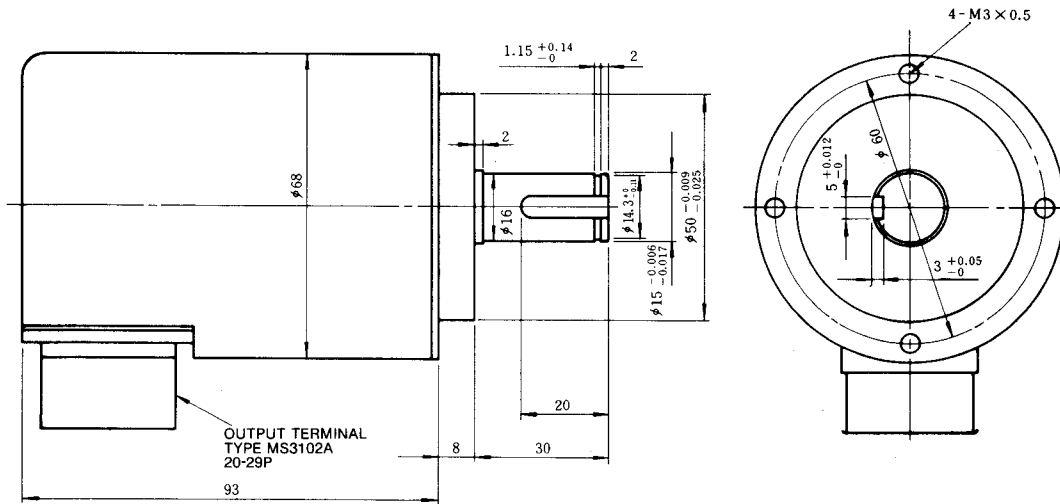

• Specifications

Power Supply	+5 VDC $\pm 5\%$, 350 mA max	
Number of Pulses	A- and B-phases: 1024 p/rev C-phase: 1 p/rev	
Max Response Speed	4k: 4000 r/min 6k: 6000 r/min	
Operation Temperature	0 to + 60°C	
Output Terminals	Type MS3102A, 20-29P	
Input Shaft Inertia	$1 \times 10^{-3} \text{ kg} \cdot \text{cm} \cdot \text{s}^2$ max	
Input Starting Torque	1kg · cm max	
Allowable Input Shaft Load	Thrust Load	At stop: 10 kg max, At rotating: 2 kg max
	Radial Load	At stop: 20 kg max, At rotating: 3 kg max
Approx Mass	1.5 kg	

• Output Terminal Layout

A	PA	G		N	*PA
B	PC	H	+5V	P	*PC
C	PB	J		R	*PB
D		K	0V	S	
E	FG	L		T	
F		M			

APPENDIX A DIMENSIONS in mm (Cont'd)

(b) Types PC-1024ZL-4K-68, PC-1024ZL-6K-68

Drawing No.: DE6429540

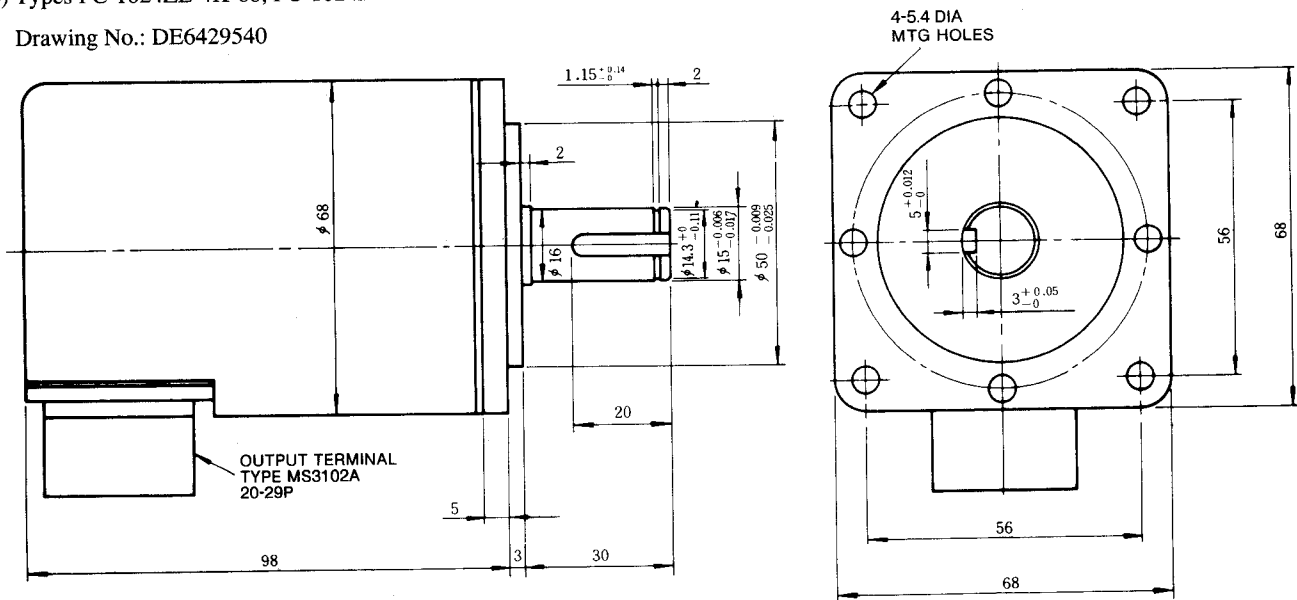

• Specifications

Power Supply	+5 VDC $\pm 5\%$, 350 mA max
Number of Pulses	A- and B-phase: 1024 p/rev C-phase: 1 p/rev
Max Response Speed	4k: 4000 r/min 6k: 6000 r/min
Operation Temperature	0 to +60°C
Output Terminals	Type MS3102A, 20-29P

Input Shaft Inertia	$1 \times 10^{-3} \text{ kg} \cdot \text{cm} \cdot \text{s}^2 \text{ max}$	
Input Starting Torque	1kg · cm max	
Allowable Input Shaft Load	Thrust Load	At stop: 10 kg max, At rotating: 2 kg max
	Radial Load	At stop: 20 kg max, At rotating: 3 kg max
Approx Mass	1.5 kg	

• Output Terminal Layout

A	PA	G	N	*PA
B	PC	H	+5V	*PC
C	PB	J	R	*PB
D		K	0V	S
E	FG	L	T	
F		M		

(c) Types PC-1024ZL-4K-160, PC-1024ZL-6K-160

Drawing No.: DE6429541

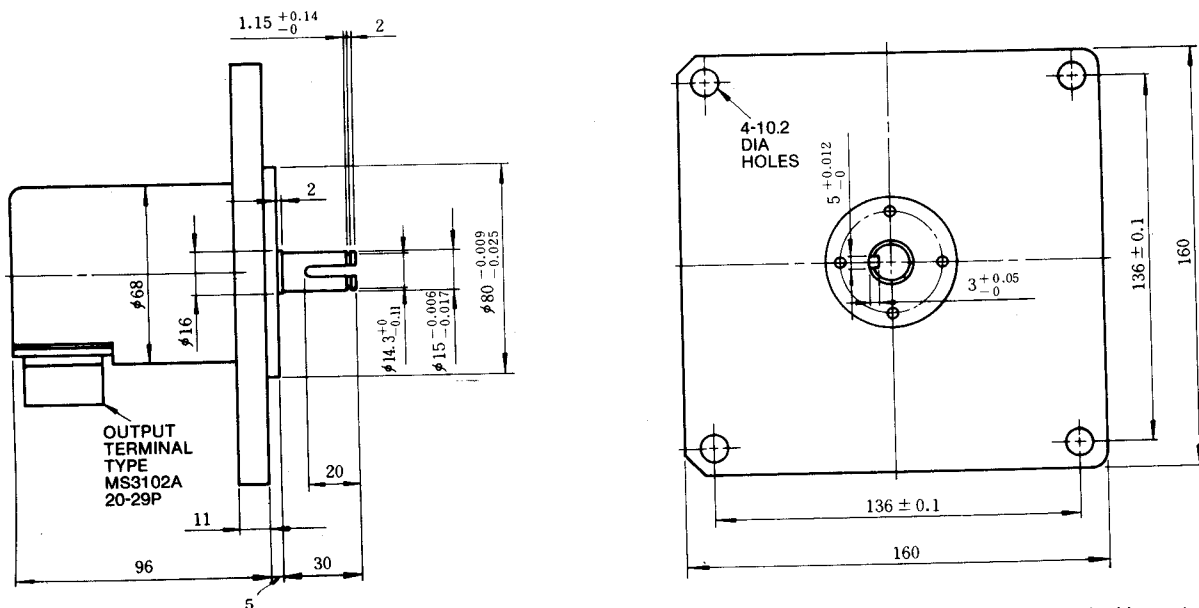

• Specifications

Power Supply	+5 VDC $\pm 5\%$, 350 mA max
Number of Pulses	A- and B-phase: 1024 p/rev C-phase: 1 p/rev
Max Response Speed	4k: 4000 r/min 6k: 6000 r/min
Operation Temperature	0 to +60°C
Output Terminals	Type MS3102A, 20-29P

Input Shaft Inertia	$1 \times 10^{-3} \text{ kg} \cdot \text{cm} \cdot \text{s}^2 \text{ max}$	
Input Starting Torque	1kg · cm max	
Allowable Input Shaft Load	Thrust Load	At stop: 10 kg max, At rotating: 2 kg max
	Radial Load	At stop: 20 kg max, At rotating: 3 kg max
Approx Mass	1.5 kg	

• Output Terminal Layout

A	PA	G	N	*PA
B	PC	H	+5V	*PC
C	PB	J	R	*PB
D		K	0V	S
E	FG	L	T	
F		M		

APPENDIX B

(1) I/O Area Classification

I/O area numbers of rotary switch are shown below.

Table A.1 I/O Area Classification

SW 1	I/O Area No.		
	SP 50	FC 861	FC 810/ FC 860
0	Setting ineffective	Setting ineffective	Setting ineffective
1	1-1	1-1	1
2	1-2	1-2	Setting ineffective
3	2-1	2-1	2
4	2-2	2-2	Setting ineffective
5	3-1	3-1	3
6	3-2	3-2	Setting ineffective
7	4-1	4-1	4
8	4-2	4-2	Setting ineffective
9 to F	Setting ineffective		

(2) Address Classification

Address classifications of SP 50, FC 861, FC 810 and FC 860 are shown below.

Table A.2 Input Port

SP 50		FC 861		FC 810/FC 860	
Area No.	Address Port	Area No.	Address Port	Area No.	Address Port
1-1	#1000 to #1007	1-1	#1000 to #1007	1	#1000 to #1013
1-2	#1008 to #1015	1-2	#1008 to #1015		
2-1	#1016 to #1023	2-1	#1016 to #1023	2	#1016 to #1029
2-2	#1024 to #1031	2-2	#1024 to #1031		
3-1	#1032 to #1039	3-1	#1032 to #1039	3	#1032 to #1045
3-2	#1040 to #1047	3-2	#1040 to #1047		
4-1	#1048 to #1055	4-1	#1048 to #1055	4	#1048 to #1061
4-2	#1056 to #1063	4-2	#1056 to #1063		

Table A.3 Output Port

SP 50-1		SP 50-2		FC 861		FC 810/FC 860	
Area No.	Address Port	Area No.	Address Port	Area No.	Address Port	Area No.	Address Port
1-1	#1100 to #1103	1-1	#1100 to #1106	1-1	#1100 to #1106	1	#1100 to #1111
1-2	#1108 to #1111	1-2	#1108 to #1114	1-2	#1108 to #1114		
2-1	#1116 to #1119	2-1	#1116 to #1122	2-1	#1116 to #1122	2	#1116 to #1127
2-2	#1124 to #1127	2-2	#1124 to #1130	2-2	#1124 to #1130		
3-1	#1132 to #1135	3-1	#1132 to #1138	3-1	#1132 to #1138	3	#1132 to #1143
3-2	#1140 to #1143	3-2	#1140 to #1146	3-2	#1140 to #1146		
4-1	#1148 to #1151	4-1	#1148 to #1154	4-1	#1148 to #1154	4	#1148 to #1159
4-2	#1156 to #1159	4-2	#1156 to #1162	4-2	#1156 to #1162		

(3) Invert Process

Logic can be set to “1” by short-pin SW2 setting of FC810, FC860, FC861 when the input contact is “closed” disregarding whether common 0V or 24V is used.

The following shows the inverted bit areas in the common status of each board.

Table A.4 Inverted Bit Area

Common Connector Terminal	FC810/FC860 INterval Area			
	Area No. 1	Area No. 2	Area No. 3	Area No. 4
COM 30	#1000 , #1001	#1016 , #1017	#1032, #1033	#1048, #1049
COM 31	#1002, #1003	#1018, #1019	#1034 , #1035	#1050, #1051
COM 32	#1004	#1004	#1004	#1004
COM 40	#1005, #1006	#1021, #1022	#1037, #1038	#1053, #1054
COM 41	#1007, #1008	#1023, #1024	#1039, #1040	#1055, #1056
COM 42	#1009	#1004	#1004	#1004
COM 20	#1010, #1011	#1026, #1027	#1042, #1043	#1058, #1059
COM 21	#1012	#1028	#1044	#1060
COM 10	#1013	#1029	#1045	#1061

Table A.5 Inverted Bit Area

Common Connector Terminal	FC 810/FC 860 Inverted Area			
	Area No. 1-1	Area No. 1-2	Area No. 2-1	Area No. 2-2
COM 00	#1000, #1001	#1008, #1009	#1016 , #1017	#1024, #1025
COM 01	#1002	#1010	#1018	#1026
COM 02	#1003, #1004	#1011, #1012	#1019 , #1020	#1027, #1028
COM 03	#1005	#1013	#1021	#1029
COM 04	#1006, #1007	#1014, #1015	#1022, #1023	#1030, #1031
	Area No. 3-1	Area No. 3-2	Area No. 4-1	Area No. 4-2
COM 00	#1032, #1033	#1040, 1041	#1048, #1049	#1056, #1057
COM 01	#1034	#1042	#1050	#1058
COM 02	#1035, #1036	#1043, #1044	#1051, #1052	#1059, #1060
COM 03	#1037	#1045	#1053	#1061
COM 04	#1038, #1039	#1046, #1047	#1054, #1055	#1062, #1063

APPENDIX C STANDARD WIRING COLORS OF YASNAC

The standard wiring colors of YASNAC are as follows:

Items		Wiring
Circuit		Green
Main Circuit	200 VAC	Black
	100 VAC	Yellow
Control Circuit (100 VAC)		Yellow
DC Power Circuit	+5 V, 24 V	Red
	0 V	Black
DC Signal Line	0.2 SG	Gray
	Other than 0.2 SG	Brown
Ground Wire		Green / Yellow

NOTES

YASNAC J50 CONNECTING MANUAL

TOKYO OFFICE Ohtemachi Bldg, 1-6-1 Ohtemachi, Chiyoda-ku, Tokyo, 100 Japan

Phone (03) 3284-9111 Telex YASKAWA J33530 Fax (03) 3284-9034

YASKAWA ELECTRIC AMERICA, INC.

Chicago-Corporate Headquarters 2942 MacArthur Blvd. Northbrook, IL 60062-2028, U.S.A.

Phone (708) 291-2340 Fax (708) 498-2430

Chicago-Technical Center 3160 MacArthur Blvd. Northbrook, IL 60062-1917, U.S.A.

Phone (708) 291-0411 Fax (708) 291-1018

MOTOMAN INC.

805 Liberty Lane West Carrollton, OH 45449, U.S.A.

Phone (513) 847-6200 Fax (513) 847-6277

YASKAWA ELÉTRICO DO BRASIL COMÉRCIO LTDA.

Rua Conde Do Pinhal 8-5, Andar Sala 51 CEP 01501-São Paulo-SP, Brasil

Phone (011) 35-1911 Fax (011) 37-7375

YASKAWA ELECTRIC EUROPE GmbH

Am Kronberger Hang 2, 65824 Schwalbach, Germany

Phone (49) 6196-569-300 Fax (49) 6196-888-301

Motoman Robotics AB

Box 130 S-38500, Torsås, Sweden

Phone 0486-10575 Fax 0486-11410

Motoman Robotec GmbH

Kammerfeldstraße 1, 85391 Allershausen, Germany

Phone 08166-900 Fax 08166-9039

YASKAWA ELECTRIC UK LTD.

3 Drum Mains Park Orchardton Woods Cumbernauld, Scotland, G68 9LD U.K.

Phone (1236)735000 Fax (1236)458182

YASKAWA ELECTRIC KOREA CORPORATION

Paik Nam Bldg, 901 188-3, 1-Ga Euljiro, Joong-Gu Seoul, Korea

Phone (02)776-7844 Fax (02)753-2639

YASKAWA ELECTRIC (SINGAPORE) PTE. LTD.

Head Office : CPF Bldg, 79 Robinson Road # 13-05, Singapore 0106, SINGAPORE

Phone 221-7530 Telex (87) 24890 YASKAWA RS Fax 224-5854

Service Center : 221 Henderson Road, # 07-20 Henderson Building Singapore 0315, SINGAPORE

Phone 276-7407 Fax 276-7406

YATEC ENGINEERING CORPORATION

Shen Hsiang Tang Sung Chiang Building 10F 146 Sung Chiang Road, Taipei, Taiwan

Phone (02) 563-0010 Fax (02) 567-4677

SHANGHAI OFFICE Room No. 8B Wan Zhong Building 1303 Yan An Road (West), Shanghai 200050, CHINA

Phone (86) 212-1015 Fax (86) 212-1015

TAIPEI OFFICE Shen Hsiang Tang Sung Chiang Building 10F 146 Sung Chiang Road, Taipei, Taiwan

Phone (02) 563-0010 Fax (02) 567-4677



YASKAWA

YASKAWA ELECTRIC CORPORATION

TOE-C843-12.2B

© Printed in Japan September 1995 94-9 (