

VS-606 V7 OPTION UNIT
PROFIBUS-DP INTERFACE UNIT
INSTRUCTIONS

MODEL: SI-P1/V7

Upon receipt of the product and prior to initial operation, read these instructions thoroughly and retain them for future reference.



Safety Information

Read this instruction manual and the related documents thoroughly before installation, operation, maintenance or inspection of this product. Make sure you understand product information, all precautions and safety information before using the product. Also, keep this manual in a convenient location so that it can be referred to whenever necessary.

The following conventions are used to indicate precautions in this manual.



Indicates precautions that, if not heeded, could possibly result in loss of life or serious injury.



Indicates precautions that, if not heeded, could result in relatively serious or minor injury, damage to the product, or faulty operation.

Even items described in  may result in a vital accident in some situations.

In either case, follow these important notes.

NOTE

: Items to be observed by users are described in the relevant sections.

WARNING

- **After turning OFF the main circuit's power supply, wait until the CHARGE indicator light goes out before connecting wires to the connectors or to the external terminals of the SI-P1/V7.**

The capacitor will remain charged and is dangerous.

CAUTION

- **A CMOS IC is used for the SI-P1/V7 unit. Handle the control board and CMOS IC carefully. The CMOS IC can be destroyed by static electricity if touched directly.**

- **To remove the SI-P1/V7 unit from the inverter and transport or store it separately, keep the optional unit in the anti-static electricity package used to protect the unit at delivery.**

- **Do not change the wiring or remove/insert the connectors while the power is turned ON.**

Failure to observe this caution may result in injury.

NOTE

: Before Use

- (1) Read this instruction manual, SI-P1/V7 User's Manual and the instruction manual of the inverter on which this optional unit is mounted before using the PROFIBUS-DP Communications Interface Unit SI-P1/V7.
- (2) The GSD file, which is not included with the SI-P1/V7, is needed to use the SI-P1/V7 in the PROFIBUS-DP slave. When the slave is registered in the GSD file in the PROFIBUS-DP master, the master also recognizes the SI-P1/V7 unit, and then the SI-P1/V7 can be used in the registered slave. To obtain the GSD file, please contact your Yaskawa representative.

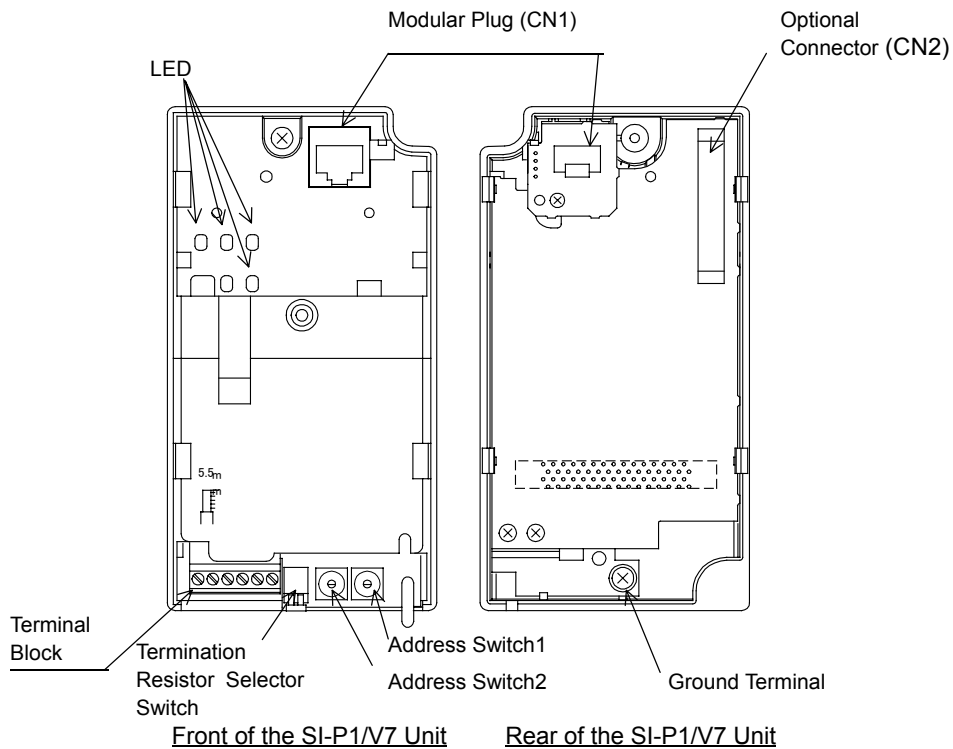

Fig. 1 PROFIBUS-DP Communications Interface Unit SI-P1/V7

1 OUTLINE OF PRODUCT

The PROFIBUS-DP Communication Interface Unit SI-P1/V7 is an option unit that can be mounted on the VS-606V7 Inverter and used for communications with the PROFIBUS-DP master.

Three types of I/O data length (32 bytes, 12bytes, 6bytes) can be selected. The run/stop status can be monitored and the inverter internal constants can be set/changed from the PROFIBUS-DP master.

The SI-P1/V7 unit can be mounted on these inverters.

VS-606V7:Standard series (Operates on inverter software No.0020 or later edition)

Name	Code No.	Function
SI-P1/V7 PROFIBUS-DP Communication Interface Unit SI-P1/V7	73606-V711X	PROFIBUS data Extended data 1 (Data length:32 bytes) High-speed I/O data area (input:16bytes, output 16bytes) MEMOBUS message (input:16bytes, output 16bytes) Extended data 2 (Data length:12bytes) High-speed I/O data area (input:4bytes, output 4bytes) MEMOBUS message (input:8bytes, output 8bytes) Basic data (Data length:6 bytes) High-speed I/O data area (input:6bytes, output 6bytes) Communication speed:9.6kbps to 12Mbps



Specify the name and code number when ordering the PROFIBUS-DP Communications Interface Unit SI-P1/V7.

2 RECEIVING

! CAUTION
<p>Verify that the product received is the product ordered. Installing the wrong product may cause injury or equipment damage.</p>

Products are rigorously inspected before delivery. Confirm the following points before installation.

Item	Inspection Method
Is the product what you have ordered?	Check it with the nameplate on the side of the SI-P1/V7 Unit (see 2.1.)
Is the inverter damaged?	Check the SI-P1/V7 Unit visually for any damage that may have occurred during transport.
Are any parts missing?	Check the parts list (see 2.2.)

Contact your Yaskawa representative immediately if any problem should be found concerning the shipment.

2.1 Nameplate

The following diagram shows the nameplate on the side of the SI-P1/V7 Unit.

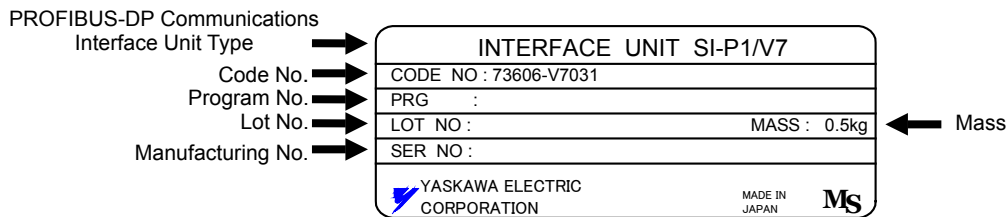

2.2 Parts List

The SI-P1/V7 Unit contains the following parts.

Parts Name	Q'ty
PROFIBUS-DP Communications Interface Unit	1
Mounting fixture	1
M3 × 8SW screw	1
Grounding cable (small): 150 mm	1
Grounding cable (medium): 220 mm	1
Grounding cable (large): 330 mm	1

3 INSTALLATION

The SI-P1/V7 Unit is mounted with the digital operator and the front cover of the inverter removed. To mount the unit, do the following.

- 1) Turn OFF the inverter's power supply and remove the digital operator and the front cover and then wait one minute after all the LEDs are turned OFF.
- 2) See Fig.1 for the three places where you should cut off the cover of the inverter's CN2 connector. Use nippers to cut it off. Be careful so that the nippers do not fall into the inverter unit. Should they fall in, be sure to remove them.
- 3) Fix the mounting fixture as shown in Fig.1.
- 4) Connect the correct grounding cable to the grounding screw shown in Fig.3 before mounting the SI-P1/V7 unit on the inverter. Three types of grounding cables corresponding to various inverter capacities are provided. Connect the correct cable with a crimped terminal. See Table 1.
- 5) Slowly mount the SI-P1/V7 unit on the main body of the inverter so that it is straight. When mounting, confirm that CN1 and CN2 are in the top half. (The wiring to the inverter must be completed in advance. After mounting the SI-P1/V7 unit, the terminal for inverter is hidden from view.)
- 6) Refer to Fig.2 for the location of the screws to screw the SI-P1/V7 unit on the inverter. The screw is already screwed in on the interface unit.
- 7) Connect the grounding cable for the SI-P1/V7 to the grounding terminal on the main body of the inverter.
- 8) Put the digital operator and the front cover back.

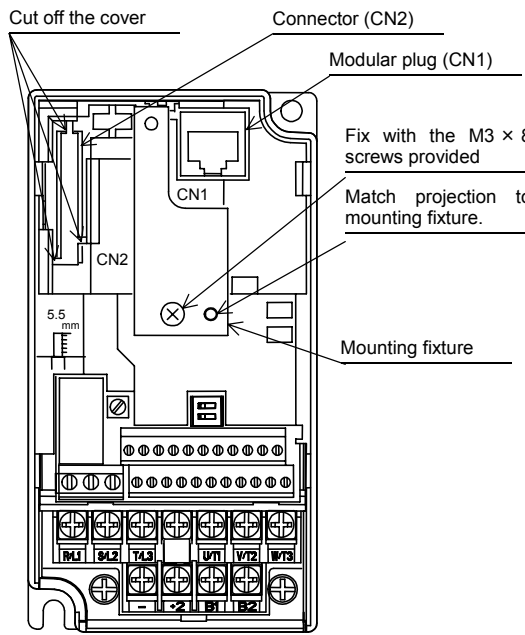

Fig. 1 Front of Inverter

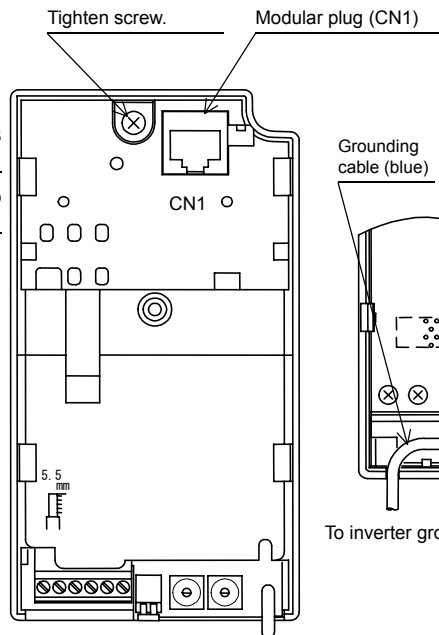

Fig. 2 Front the SI-P1/V7 Unit

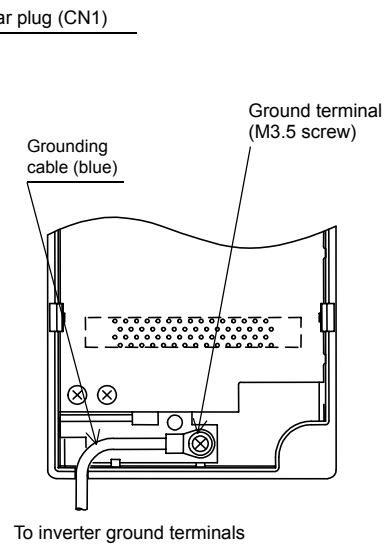

Fig. 3 Rear the SI-P1/V7 Unit

Table 1 Grounding Cables Corresponding to Inverter Capacity

Cable	Capacity of Inverter
Grounding cable (small): 150 mm	200V (single-phase): 0.1kW to 0.4kW, 200V (3-phase): 0.1kW to 0.75kW
Grounding cable (medium): 220 mm	200V (single-phase): 0.75kW to 3.7kW, 200V (3-phase): 1.5kW to 3.7kW, 400V (3-phase): 0.2kW to 3.7kW
Grounding cable (large): 300 mm	200V (3-phase): 5.5kW, 7.5kW, 400V (3-phase): 5.5kW, 7.5kW

4 INTERCONNECTION

Fig.2 shows the interconnection between the inverter, the SI-P1/V7 unit and the PROFIBUS-DP master.

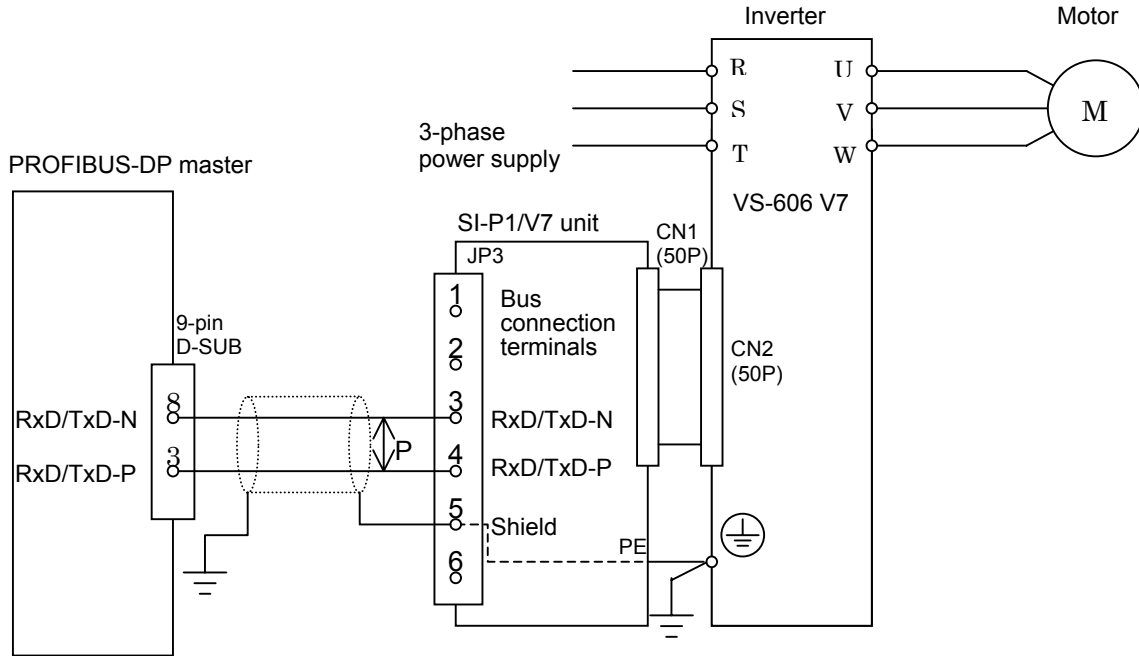

Fig. 2 Interconnection between Devices

NOTE

Precautions on Wiring

- (1) Separate the wiring for SI-P1/V7 communications from the main circuit wiring or other power cables.
- (2) Use a shielded twisted-pair cable conforming with the PROFIBUS specifications for the communications cable.

5 WIRING

(1) Table 2 shows the functions of the SI-P1/V7 PROFIBUS-DP bus connection terminals.

Table 2 Function of PROFIBUS-DP Bus Connection Terminals

Terminal No.	Name	Explanation
1	+5V BUS	Not used.
2	GND BUS	Not used.
3	A-Line	Minus RxD/TxD according to RS-485 specifications
4	B-Line	Plus RxD/TxD according to RS-485 specifications
5	Shield	Shielded connection terminal of bus cable
6	RTS	Not used.

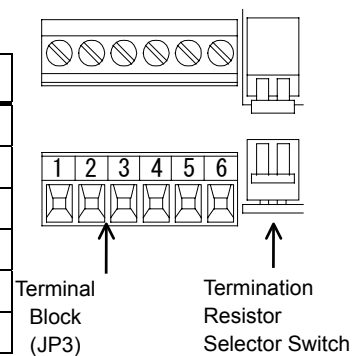

(2) To wire the PROFIBUS-DP master and the terminal for the SI-P1/V7 unit, use a shielded twisted-pair cable and do the following.

1) The following chart shows the applicable cable sizes for the terminal block JP3.

[Terminal: MINI COMBICON series, made by Phoenix Contact Co., Ltd.]

	[mm ²]	AWG	I [A]	VAC [V]
Twisted cable	0.14—1.5	28—16	8	160
Single cable	0.14—1.5	28—16	8	160
UL	—	30—14	8	300
CSA	—	28—16	8	300

2) Refer to Fig.3 for an illustration of how the end of the connecting cable on the SI-P1/V7 unit's side should be prepared.

3) Use a thin screwdriver, less than 2.5mm wide and less than 0.4mm thick, to loosen the terminal screw.

4) Connect the SI-P1/V7 unit's terminal block No. 3 with the PROFIBUS-DP master's No. 8 pin

and connect the SI-P1/V7 unit's terminal block No. 4 with the PROFIBUS-DP master's D-SUB No.3 pin. (See Fig.2.)

Stripped section of wire:
approx. 5.5mm long

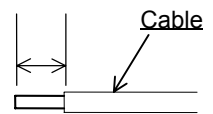

5) Insert the cable from the bottom of the terminal block.

6) Tighten the terminal screw so that the cable cannot be removed.

(Tightening torque: 0.22 to 0.25 [N · m])

Fig. 3 Connection Cable Termination at Bus Connection Terminal of the SI-P1/V7 Unit

6 SETTING

6.1 Setting of SI-P1/V7 Unit

6.1.1 Address Switch

Rotary address switches to set the slave address on the PROFIBUS-DP are provided.

Setting address switches 1 and 2 on the SI-P1/V7 unit can be used to set the inverter address on the PROFIBUS-DP.

To Set the address, do the following.

$$\text{Address} = (\text{setting of address switch 2}) \times 10 + (\text{setting of address switch 1}) \times 1$$

Example) To set the address to 15.

Set address switch 2 to "1".

Set address switch 1 to "5".

Address switch 2

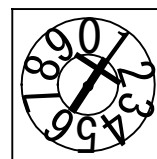

Set to 1.

Address switch 1

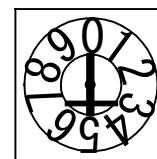

Set to 5.

6.1.2 Termination Resistor Selector Switch

To reduce the reflection of the signal and stabilise communications, a termination resistor must be attached on the end unit of the transmission line. When the SI-P1/V7 unit is connected as the end unit of the communications line, termination ON the termination resistor selector switch of the SI-P1/V7 unit will connect the termination resistor. Termination resistors do not have to be mounted externally.

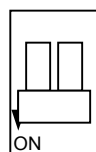

With termination resistor (Switch ON)

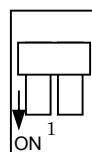

Without termination resistor (Switch OFF)

Termination Resistor Selector Switch

6.1.3 Setting of Communications Speed

When setting the communications speed is set on the PROFIBUS master, the speed for the SI-P1/V7 unit is also automatically set. The communications speed for the SI-P1/V7 unit does not have to be set.

6.2 Setting for the Inverter

Before starting communications between the inverter and the PROFIBUS-DP master, make the following settings for the constants if necessary.

Constant No.	Name	Description	Factory Setting
n003	Operation Reference Selection	0: Digital Operator 1: Control circuit terminal 2: MEMOBUS communications 3: Communications card (optional)	0
n004	Frequency Reference Selection	0: Digital Operator 1: Frequency reference 1 (n024) 2: Control circuit terminal (0-10V) 3: Control circuit terminal (4-20mA) 4: Control circuit terminal (0-20mA) 5: Pulse train 6: MEMOBUS communications 7: Digital Operator circuit terminal (0-10V) 8: Digital Operator circuit terminal (4-20mA) 9: Communications card (optional)	0

To run or stop using PROFIBUS-DP communications, set "3" to n003. To set the frequency, set "9" to n004.

6.3 Ordering the GSD Files

To configure the SI-P1/V7 unit for the PROFIBUS-DP master, the GSD file is necessary. To use the SI-P1/V7 card, register the GSD file in the PROFIBUS-DP master as slave.

The GSD file name (YASK00CA.gsd) for the SI-P1/V7 unit is the same as the GSD file name for the SI-P/V7 unit, however the GSD file version is different.

(Previous GSD file:Revision=Version1.0 → New GSD file:Revision=Version3.1)

Contact your Yaskawa representative to get the new GSD file for SI-P1/V7 unit.

The new GSD file (Version3.1) for SI-P1/V7 unit is applicable to both the SI-P1/V7 unit and the SI-P/V7 unit.

Table 3 GSD files

	Version1.0	Version3.1
SI-P/V7 unit	Applicable	Applicable
SI-P1/V7 unit	Not applicable	Applicable

VS-606 V7 OPTION UNIT PROFIBUS-DP INTERFACE UNIT INSTRUCTIONS

IRUMA BUSINESS CENTER (SOLUTION CENTER)

480, Kamifujisawa, Iruma, Saitama 358-8555, Japan
Phone 81-4-2962-5696 Fax 81-4-2962-6138

YASKAWA ELECTRIC AMERICA, INC.

2121 Norman Drive South, Waukegan, IL 60085, U.S.A.
Phone 1-847-887-7000 Fax 1-847-887-7370

YASKAWA ELÉTRICO DO BRASIL LTDA.

Avenida Fagundes Filho, 620 São Paulo-SP CEP 04304-000, Brazil
Phone 55-11-3585-1100 Fax 55-11-5581-8795

YASKAWA ELECTRIC EUROPE GmbH

Hauptstraße 185, 65760 Eschborn, Germany
Phone 49-6196-569-300 Fax 49-6196-569-398

YASKAWA ELECTRIC UK LTD.

1 Hunt Hill Orchardton Woods Cumbernauld, G68 9LF, United Kingdom
Phone 44-1236-735000 Fax 44-1236-458182

YASKAWA ELECTRIC KOREA CORPORATION

7F, Doore Bldg. 24, Yeoido-dong, Youngdungpo-Ku, Seoul 150-877, Korea
Phone 82-2-784-7844 Fax 82-2-784-8495

YASKAWA ELECTRIC (SINGAPORE) PTE. LTD.

151 Lorong Chuan, #04-01, New Tech Park 556741, Singapore
Phone 65-6282-3003 Fax 65-6289-3003

YASKAWA ELECTRIC (SHANGHAI) CO., LTD.

No.18 Xizang Zhong Road. Room 1702-1707, Harbour Ring Plaza Shanghai 200001, China
Phone 86-21-5385-2200 Fax 86-21-5385-3299

YASKAWA ELECTRIC (SHANGHAI) CO., LTD. BEIJING OFFICE

Room 1011A, Tower W3 Oriental Plaza, No.1 East Chang An Ave.,
Dong Cheng District, Beijing 100738, China
Phone 86-10-8518-4086 Fax 86-10-8518-4082

YASKAWA ELECTRIC TAIWAN CORPORATION

9F, 16, Nanking E. Rd., Sec. 3, Taipei, Taiwan
Phone 886-2-2502-5003 Fax 886-2-2505-1280



YASKAWA

YASKAWA ELECTRIC CORPORATION

In the event that the end user of this product is to be the military and said product is to be employed in any weapons systems or the manufacture thereof, the export will fall under the relevant regulations as stipulated in the Foreign Exchange and Foreign Trade Regulations. Therefore, be sure to follow all procedures and submit all relevant documentation according to any and all rules, regulations and laws that may apply.

Specifications are subject to change without notice for ongoing product modifications and improvements.

© 2002-2008 YASKAWA ELECTRIC CORPORATION. All rights reserved.

MANUAL NO. TOBZ-C736-70.4B

Published in Japan July 2008 00-7 -0
08-5-10