



Section	Page
1 <i>Introduction</i>	
Contents	3
1.1 Documentation Presentation	4
1.2 Module Description	5
1.3 Hardware Presentation	7
1.4 Hardware Installation	9
2 <i>Software Installation</i>	
Contents	13
2.1 General	15
2.2 COM Word Service	16
2.3 Text Block Reminders	26
2.4 UNI-TE Services	32
2.5 Application-to-Application Communication	39
2.6 Priority Communication - Telegram	43
2.7 PLC Scan Cycle	49
2.8 Multiple Network Configurations	50
3 <i>Maintenance</i>	
Contents	53
3.1 Troubleshooting	54
3.2 Self-Tests and Specific Tests	59
3.3 Data-Rate Control	62



Section	Page
4 <i>Technical Specifications</i>	
Contents	63
4.1 Performance	64
5 <i>Appendix</i>	
Contents	73
5.1 Module Design	74
5.2 TSX Series 7 V3 PLC Special Points	78
5.3 Uni-TE Read Requests	80
5.4 Uni-TE Write Requests	98



Sub-section	Page
1.1 Documentation Presentation	4
1.2 Module Description	5
1.2-1 General	5
1.2-2 Module Features	6
1.3 Hardware Presentation	7
1.3-1 TSX MAP 1074 Module	7
1.3-2 TSX MAP ACC1 Terminal Block	8
1.4 Hardware Installation	9
1.4-1 Installing the Module in the Rack	9
1.4-2 Coding the Address in the Terminal Block	10
1.4-3 Connection to the Network	11

1.1 Documentation Presentation

The TSX MAP 1074 Mapway Module User's Manual is designed for users installing a TSX MAP 1074 Module in a TSX Series 7 PLC and connecting to a Mapway network.

The complete documentation set and the points covered are described below:

The Mapway Reference Manual (TSX DR MAP V4E) covers Mapway network:

- Operating principles,
- Installation and testing principles,
- Implementation of Control, Adjust and Diagnostic functions,
- Technical characteristics.

Specialized User's Manuals (including this manual) are available for each device or family of devices that can be connected to a Mapway network. The main points covered by these manuals include:

- Device description,
- Mapway network implementation or connection of each device,
- Mapway network performance,
- Mapway network operation with Telemecanique terminals or programs,
- Remote diagnostics functions via the network.

This manual (TSX DM MAP 107 V4E) and the Mapway Network Reference Manual (TSX DR MAP V4E) are supplied with the TSX MAP 1074 module. These A5 format manuals can be inserted in an A5 format binder with dividers. The TSX DAC 1 binder must be ordered separately.

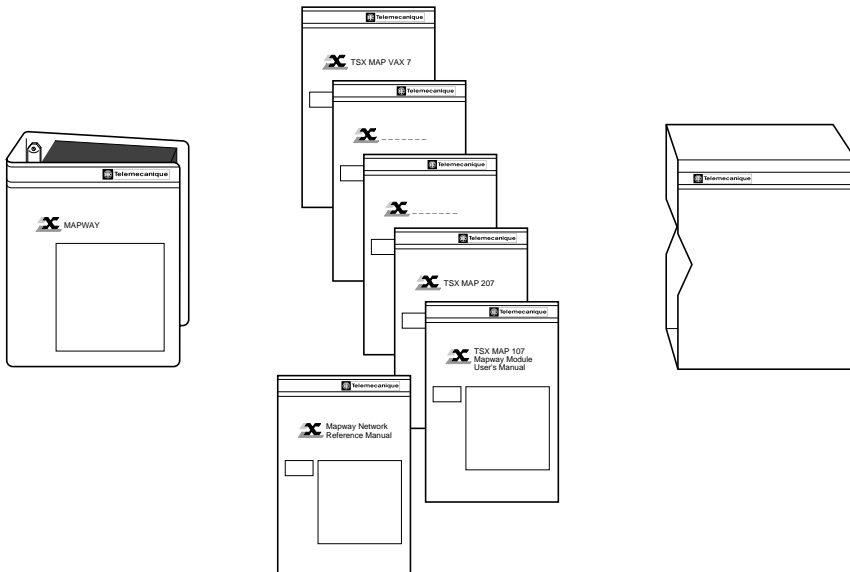

1.2 Module Description

1.2-1 General

The TSX MAP 1074 module is an intelligent module for use with TSX Series 7 modular PLCs. It can be installed in TSX Series 7 Model 40 PLCs (TSX 47-40, TSX 67-40, TSX 87-40 and TSX 107-40 PLCs) with the following processor modules:

- TSX P47-420,
- TSX P67-410/420,
- TSX P87-410/420,
- TSX P107-410/420,

and in TSX Series 7 V3 PLCs:

- TSX 47-31,
- TSX 67-21,
- TSX 87-31.

The module can be used for communication between the PLC and other devices in an X-WAY automation system.

These devices include:

- Telemecanique modular PLCs described above,
- Telemecanique TSX T607 or TSX T407 programming terminals connected to the programming port of a PLC on the network,
- Telemecanique FTX 507 workstations directly connected to the network or connected to the programming port of a PLC on the network,
- IBM PC or compatible microcomputers equipped with a PC-AT (ISA) bus,
- Telemecanique Monitor 77 supervision systems,
- Digital Equipment Corporation (DEC) MicroVAX and IVAX minicomputers,
- NUM robot or machine tool numerical controllers.

The network interfaces required depend on the device to connect to Mapway:

- TSX MAP 1074 module for PLCs,
- TSX MAP PC74 interface board for FTX 507, Monitor 77 and all IBM PC and compatible microcomputers,
- TSX MAP VAX74 or TSX VAX174 interface boards for DEC MicroVAX and IVAX minicomputers.

This manual describes the TSX MAP 1074 module for use with Telemecanique PLCs.

1.2-2 Module Features

The TSX MAP 1074 module supports Mapway network connection. The module is connected to the Mapway network through a TSX MAP ACC1 terminal block. The terminal block connects to the module via a Sub-D type connector and to the Mapway network drop cable via a type F connector. The address of the connected device on the network (station and network numbers) is set in the terminal block.

The Mapway network uses 75 Ohm coax. cable to interconnect the various devices. The transmission data-rate is 5 Megabits/second (Mb/s). The network access method is a Token bus in a logical ring.

The application services use standard Telemecanique protocols: COM word services and Uni-TE requests.

The Mapway network supports:

- A virtual extension of the memory bus to PLCs connected to the network and using the COM (common) word service,
- The exchange of messages (text blocks) between two network stations in point-to-point or broadcast modes to all network stations,
- Remote access for all FTX 507 workstation functions when connected to the network or to the programming port of a PLC.

Ease of Use

The TSX MAP 1074 module can operate immediately on power-up in the PLC rack, without the need for downloading a configuration.

Operational Safety

The TSX MAP 1074 module is electrically isolated from the network. In addition, the terminal block that connects the module to the network can be inserted and removed under power.

Self-Tests

Each time the module is powered-up, it runs a series of self-tests of its internal logic. These self-tests include a test of the entire network as seen by the module. Any signs of incorrect operation are displayed on the front panel of the module by a set of LED indicators and 7 segment displays. Any faults detected are also sent to the PLC.

Watchdog

Each TSX MAP 1074 module has a built-in watchdog. If the module fails, its exchanges with the network are disabled in order to protect the network.

1.3 Hardware Presentation

1.3-1 TSX MAP 1074 Module

The TSX MAP 1074 module is a single height module that can be installed in any slot of the basic PLC rack in a PLC configuration.

The module comprises:

- ① A metal case that protects the electronics of the module and ensures shielding from interference.
- ② A green "RUN" LED that lights when the module is powered-up and operating normally.
- ③ A red "DEF" (fail) LED that lights when a module fault is detected.
- ④ Three yellow LEDs that indicate the status of the module in relation to the Mapway network:
 - INR: Station in the logical ring,
 - RX: Station receiving data,
 - TX: Station transmitting data.
- ⑤ Two 7 segment LED displays for displaying module operating data.
- ⑥ A female Sub-D 11-point connector.
- ⑦ Two mounting screws that retain the module in the rack.

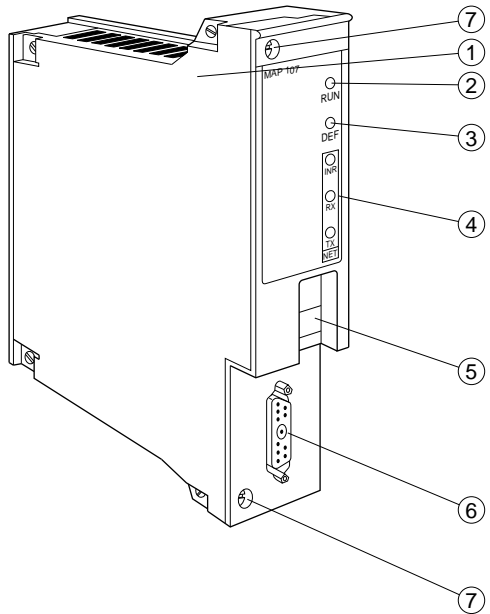

The rear panel of the module is equipped with factory-coded locating devices which prevent any risk of error when modules are installed.

1.3-2 TSX MAP ACC1 Terminal Block

The terminal block is used to connect TSX MAP 1074 modules and their TSX Series 7 PLCs to the Mapway network. It performs the following functions:

- Connection of TSX MAP 1074 modules to the Mapway network via a male Sub-D connector between the terminal block and the module and a type F connector between the terminal block and Mapway,
- Module addressing on the Mapway network. The station and network numbers are set in hexadecimal in the terminal block, on four thumbwheel switches.

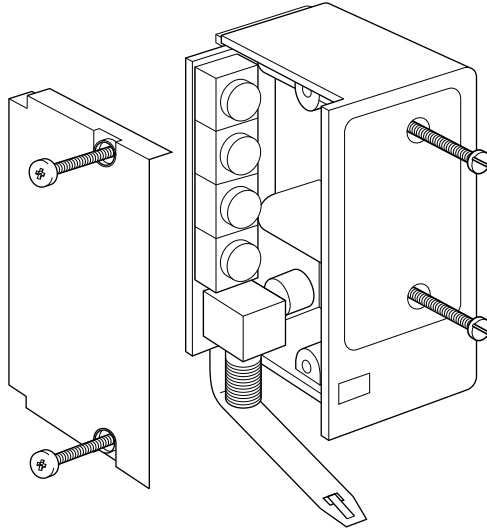

Module and terminal block dimensions

The terminal block is fitted with a plastic tab that attaches the terminal block to the PLC rack at the location of the TSX MAP 1074 module. Attaching the terminal block makes it possible to replace a module without disconnecting the terminal block from the network cabling ensuring that will not be incorrectly reconnected.

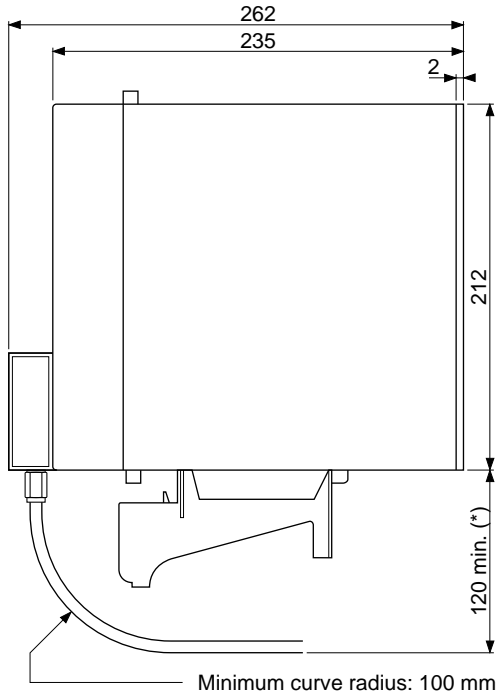

(*) 18 with TSX MAP ACC9 90° angle connector adaptor.

1.4 Hardware Installation

1.4-1 Installing the Module in the Rack

TSX Series 7 Model 40 PLCs:

TSX 47-40	Slots 0 to 7	1 module max.
TSX 67-40	Slots 0 to 7	2 modules max.
TSX 87-40	Slots 0 to 7	4 modules max.
TSX 107-40	Slots 0 to 7	4 modules max.

TSX Series 7 V3 PLCs:

TSX 47-31	Slots 0 to 7	1 module max.
TSX 67-21	Slots 0 to 7	1 module max.
TSX 87-31	Slots 0 to 7	1 module max.

Note: Regardless of the type of PLC used, TSX MAP 1074 modules can only be installed in the main configuration rack.

Hardware and software codes

Hardware code A two figure decimal code that is set on the locating devices on the rear of the module.	13
Software code A decimal code entered from the programming terminal with the I/O configuration of the PLC.	Model 40: 13 V3 PLCs: 12

Network installation

The network cables, tap junctions and other components should be installed according to the procedures described in the Mapway Network Reference Manual (TSX DR MAP V4E).

1.4-2 Coding the Address in the Terminal Block

The thumbwheel switches are accessed by removing the side cover of the terminal block. Once this is done, it is possible to remove the circuit board that supports the four thumbwheel switches and the type F connector.

Each station in a network layout is assigned a double identification number:

- **STAT:** The station number on the network. It can take a value from 0 to 3F (for a total of 64 stations),
- **NET:** The network number. It can take a value from 0 to 7F.

This double number is coded in Hexadecimal by the four thumbwheel switches in the terminal block, as shown in the example below. A Mapway network can comprise up to 64 stations per network segment.

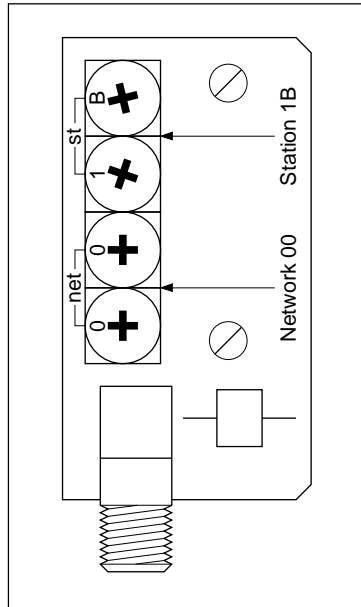

Example

The coding shown on the thumbwheel switches illustrated above corresponds to the address of station 27 (H'1B') on network 3 (H'03').

Reminder: The addressing principles and the operation of the Mapway network are described in section 3 of the Mapway Network Reference Manual (TSX DR MAP V4E). Network number 0 is reserved for single network layouts. In multiple network layouts, network numbers 1 to H'7F' should be used.

1.4-3 Connection to the Network

Once the module is installed in the PLC rack and the terminal block with the address coding is connected to it and the network, then the module is connected to the Mapway network.

When the PLC is powered-up, all of the LEDs on the module light momentarily and the self-tests start. The “RUN” LED blinks while the self-tests are in progress and remains lit once they are completed correctly. This LED shows that the module is operating correctly.

The “RUN” LED is extinguished if the module watchdog is triggered and the module becomes idle.

The “INR” (IN Ring) LED shows that the TSX MAP 1074 module is connected to the Mapway network and is active in passing the token on the bus. This means that the module is ready to send and receive messages.

The “INR” LED remains off during the self-test phase and it only lights once these are completed successfully. Until this LED lights, the module can only receive messages, it cannot transmit on the network.

The “RX” and “TX” LEDs show that the TSX MAP 1074 module has detected data reception (RX) or transmission (TX) activity on the network.

The 7 segment LED displays are used to display different types of information. While the module is operating normally, they display two types of information at two second intervals:

- The network number with a decimal point at the lower right of the display, e.g. network 2,

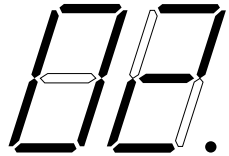

- The station number without a decimal point, e.g. station 1A.

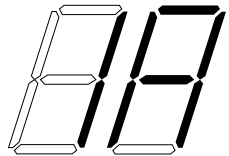

If a fault occurs during the self-test phase or during normal operation, the displays will show an error code. Refer to section 3, Maintenance, for further information.



Sub-section	Page
2.1 General	15
2.1-1 Functions	15
2.1-2 Module Configuration	15
2.2 COM Word Service	16
2.2-1 General	16
2.2-2 Common Memory Organization	17
2.2-3 COM Words in Multiple Network Layouts	18
2.2-4 COM Word Configuration	20
2.2-5 System Bits and Words	22
2.2-6 Application Examples	24
2.3 Text Block Reminders	26
2.3-1 Description	26
2.3-2 Communication by TXT Text Block	26
2.3-3 Communication by SYS Text Block	30
2.3-4 Table Layout	31
2.4 UNI-TE Services	32
2.4-1 General	32
2.4-2 Server PLC	33
2.4-3 Client PLC	35
2.5 Application-to-Application Communication	39
2.5-1 Point-to-Point Messages	39
2.5-2 Broadcast Messages	40
2.5-3 Point-to-Point Message Example	41



Sub-section	Page
2.6 Priority Communication - Telegram	43
2.6-1 General	43
2.6-2 Telegram Programming	45
2.6-3 Telegram Example	46
2.7 PLC Scan Cycle	49
2.8 Multiple Network Configurations	50
2.8-1 Module Configuration	50
2.8-2 PLC Cycle Time	51

2.1 General

2.1-1 Functions

The TSX MAP 1074 module supports the functions defined for the Mapway network. These functions include:

- Carrying UNI-TE messages from the PLC processor to the network and vice versa. This message system supports access to variables (all PL7 objects) for reading and writing, program transfer and PLC operating mode control,
- Application program to application program communication in point-to-point mode from any station in the network layout to any other station, or broadcast messages on the network,
- High priority fast communication between application programs (short 16 byte exchanges) between two PLCs on the same network, in the form of telegrams (TLG),
- Cyclic broadcasting of the distributed COM word data base between PLCs on the same network,
- Overall network management, especially message routing between networks.

During each PLC cycle, 2 messages can be sent on the network in normal operation, up to four messages per cycle can be sent at peak load. In the same way, at the start of each PLC cycle, the PLC can receive two messages in normal operation (four during peaks) from the PLC.

The TSX MAP 1074 module can handle approx. 200 messages per second. A message is a COM field sent or received or a TXT, SYS or TLG text block sent or received.

2.1-2 Module Configuration

The TSX MAP 1074 module is automatically configured on power-up. The network number (0 to H'7F') and the station number (0 to H'3F') assigned, are those set in the TSX MAP ACC1 terminal block.

The PLC will only recognize the TSX MAP 1074 module if it has been declared in the I/O configuration. If the module is not declared, it can still send messages to the PLC system, e.g. for program downloading.

2.2 COM Word Service

2.2-1 General

Note: The COM word service described below applies to TSX Series 7 Model 40 PLCs (TSX 47-40, TSX 67-40, TSX 87-40 and TSX 107-40). The COM word service available with V3 level PLCs (TSX 47-31, TSX 67-21 and TSX 87-31) is described in the Appendix, sub-section 5.2.

The complete set of COM words form a data base that is distributed among the various network stations.

Depending on their configuration, the various network stations can access a common memory field of 256 words of 16 bits. This memory field is dedicated to exchanges between PLCs.

Depending on its configuration, each station that supports this service is assigned from 4 to 64 COM words that can be written. The other words, assigned to other stations can only be read.

The COM words are updated automatically as they change, without requiring any intervention from the application program, at the same rate as the normal sequential (Master task) activity.

At the start of each Master task cycle, when the station inputs are acquired, the PLC processor reads all of the COM words that have changed in other network stations, from the network interface in the module.

Specific system bits and words ensure that the COM word update and refresh mechanism is operating correctly.

The user program simply uses PL7-3 bit or word instructions to read or write the COM words.

At the end of the Master task cycle, when the outputs are updated, the PLC processor writes the assigned COM words that have changed, to the network interface in the module.

The newly updated COM words are then sent on the network during two consecutive cycles.

Every 10 cycles, all of the COM words assigned to a station are sent on the network during two consecutive cycles.

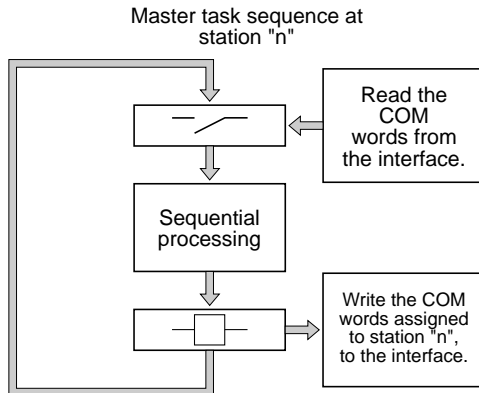

2.2-2 Common Memory Organization

Each TSX MAP 1074 module has a memory field of 256 words of 16 bits dedicated to communication between PLCs. This memory field is split into sub-blocks of words. The number of stations that send COM words on the network and their address determines the number of COM words available, as shown in the table below:

Number of stations	Number of COM words	Station addresses
2 to 4	64 max.	0 to 3
5 to 8	32 max.	0 to 7
9 to 16	16 max.	0 to H'0F'
17 to 32	8 max.	0 to H'1F'
33 to 64	4	0 to H'3F'

Example with 64 stations:

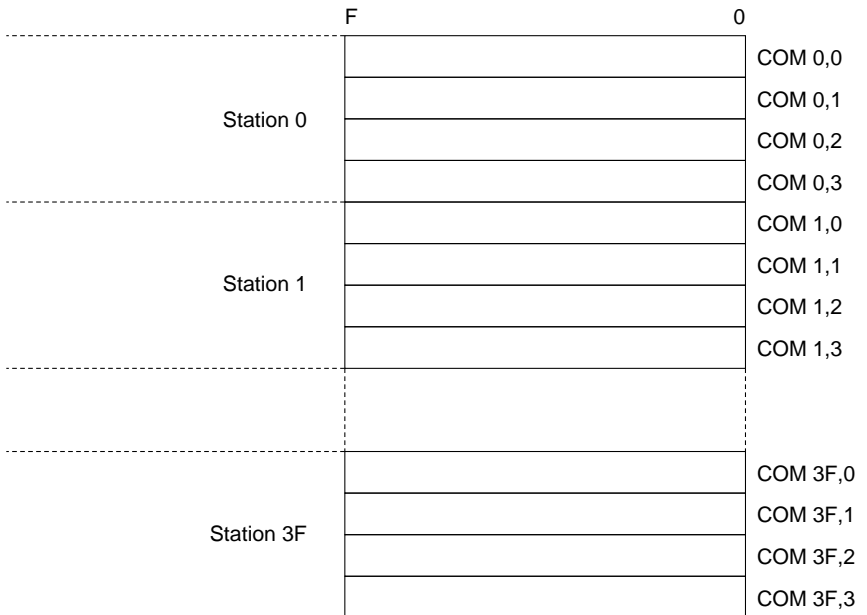

Each word in the memory can be accessed by the syntax COM_{i,j}:

where i = station number (0 to H'3F'),
 j = word position (0 to H'3F').

The internal program of TSX Series 7 PLCs enables access to the individual bits of COM words. In this case the syntax is COM_{i,j,k}:

where i = station number (0 to H'3F'),
 j = word position (0 to H'3F'),
 k = bit position (0 to H'0F').

The PLC user program:

- Writes data to be sent on the network to its own COM word field COM_{i,j},
- Reads the data from a network station by reading from the COM word field COM_{i,j} assigned to each station.

2.2-3 COM Words in Multiple Network Layouts

In a multiple network layout, some PLCs are connected to two or more different networks or network segments.

The common network field can therefore only be accessed by PLCs connected to the same network segment. These PLCs therefore have access to two or more memory fields.

To distinguish between COM words from different networks the following syntax is used COM_{x,i,j}:

where x = logical network identifier,
 i = station number,
 j = word position.

The network logical identifier takes the value B, C or D depending on the number of interface modules in the Bridge station. The identifier letter is dynamically assigned by the PLC processor, depending on the geographical location of the interface module. Each identifier letter corresponds to a dedicated memory field that is assigned to the designated network.

Example

Network connected to the module in slot 1: no identifier,
 Network connected to the module in slot 4: identifier B,
 Network connected to the module in slot 5: identifier C.

Memory field that is common to the three networks connected to the PLC.

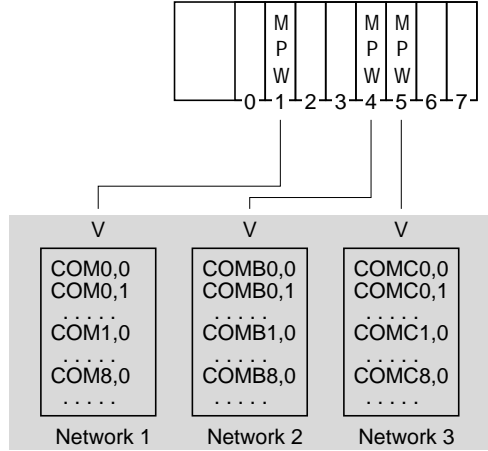

The network logical identifier does not correspond to a network number but to a geographical location. The PLC application program is independent of the network number. The user must ensure that in the application program, the logical identifier assigned by the PLC corresponds to the network that is actually connected to the module.

2.2-4 COM Word Configuration

When a TSX MAP 1074 module is configured, it is possible to:

- Inhibit it from accessing COM words,
- Validate COM word read-only access,
- Validate COM word read and write access,
- Declare the number of COM words (from 4 to 64) controlled by the station.

The number of COM words declared must be identical for all stations on the same network. If the value configured for a station is incorrect, it will be ignored by the others.

A station that reads and writes COM words sends its COM words on the network and receives the COM words sent by other network stations.

An inactive station neither sends nor receives COM words. This function reduces network traffic and the workload of each station.

A station that is active in read-only mode cannot send COM words on the network but can read those sent by other stations.

It is possible to configure a number of COM words that is less than the maximum allowed for each station. This feature must always be used when only limited amounts of information need to be sent on the network. This considerably improves COM word processing time by the PLC.

Configuration procedure

The selection is made when the application is configured by an FTX 507 workstation (with PL7-3 language in Configuration mode).

After selecting the Configure Network Service action, a screen is displayed that shows the following information for each module:

- Its type,
- Its location in the PLC,

Allowing the user to change:

- The number of COM words assigned by the module (0 by default),
- Whether or not COM words are active (inactive by default).

XTEL: Function -pl7_3- paint factory D:\xproj					
ONE	CONF	TERM	TELEMECANIQUE	U4.0	
				107/420	
COMMON WORDS SERVICE					
COUPLER	NET TYPE	RACK MOD	COM WORDS	ACTIVITY	
A	MAPWAY	0 0	32	READ AND WRITE	
B	MAPWAY	0 1	32	READ AND WRITE	
C	MAPWAY	0 3	32	READ ONLY	
D	MAPWAY	0 6	32	INACTIVE	
WORDS	ACTIVITY				

Note: When the TSX MAP 1074 module is not declared in the Input/Output configuration of the PLC, COM word exchange is not supported.

For more information on entering and configuring COM words using the programming terminals, refer to the PL7-3 Operating Modes manual (TXT DM PL7-3 V4E).

Configuring PLCs for Multiple Network Operation

Configuration of the COM words of multiple network PLCs, i.e. PLCs that have more than one TSX MAP 1074 module is performed with the PL7-NET program. This program is part of the X-TEL Software Workshop.

Among other functions, this program enables:

- Selection of stations that form a network and assignment of station addresses,
- Assignment for each Bridge station, of the modules connected to the various networks.

For more information on how to use this program, refer to the PL7-NET Program documentation (TXT DM PL7 NET V4E).

2.2-5 System Bits and Words

Some system bits and words can be used by the user program for testing the correct operation of the network and application coherence, with the PLC running and the Mapway network interface operating. The following bits and words are used by the test:

System Bit	Description	Function
SY11	COM word refresh	Normally at 0, this bit is set to 1 when a local station has received COM words from at least one remote station. It is reset to 0 by program or by the terminal, so that it can check other transmissions of COM words.
SY12	Network A operating	This bit is set to 1 once the network interface of the station has exchanged COM words with at least one other station on the network. It is reset to 0 by program or by the terminal, so that it can check other transmissions of COM words.
SY13	Network B operating	as SY12
SY14	Network C operating	as SY12
SY15	Network D operating	as SY12

System Words			
Module A	Module B	Module C	Module D
SW64	SW73	SW82	SW91
SW65	SW74	SW83	SW92
SW66	SW75	SW84	SW93
SW67	SW76	SW85	SW94
SW68	SW77	SW86	SW95
SW69	SW78	SW87	SW96
SW70	SW79	SW88	SW97
SW71	SW80	SW89	SW98
SW72	SW81	SW90	SW99

Refresh Indicators
(1 bit per station)
 Stations H'00' to H'0F',
 Stations H'10' to H'1F',
 Stations H'20' to H'2F',
 Stations H'30' to H'3F'.

Reserved words,
 Reserved words,
 Reserved words,
 Reserved words.

Module network address

Refresh indicators

The 16 bits of each word represent the 16 network stations. A bit at 1 indicates that the corresponding station has sent its COM words.

It is reset to 0 by program only, so that it can check other transmissions of COM words.

Module network address

This word indicates the network number (0 to 127) and the station number (0 to 63) corresponding to each module, in the form of:

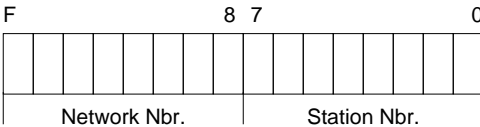

2.2-6 Application Examples

Transmission and reception of COM words

Station 0 sends status information from a door position contact (door open: B0 = 1, door closed: B0 = 0).

On receiving this information, station 1 controls a motion module by activating or deactivating its output O1,0:

- If the door is open: move the moving part forward,
- If the door is closed: stop the moving part.

Station 0 program

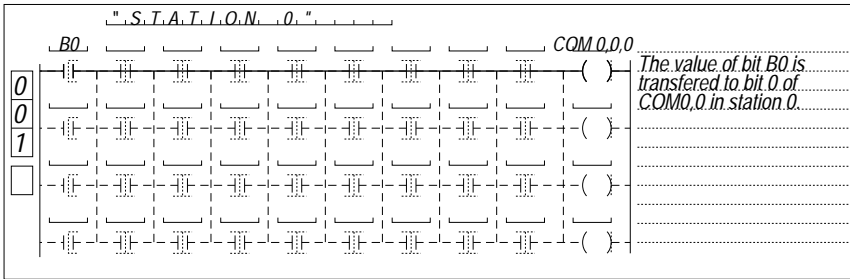

Station 1 program

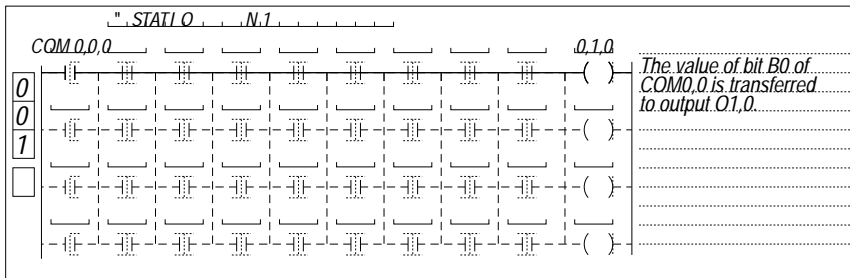

Using system bits and words

Use of system bits and words is not required in all applications. However, when a station has to check the correct operation of other stations connected to the network, the following tests can be performed:

SY12: Performs an overall check that the network is operating:

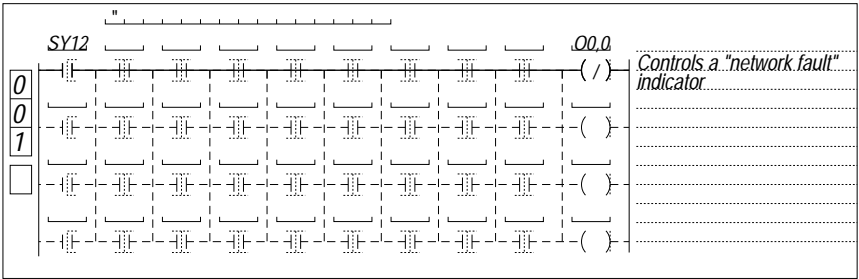

SW64: The user can check that within a set period of time that corresponds to the maximum time-out required for transferring all COM words, the bits of all the connected stations that use the COM word service have gone from 0 to 1. A branch to a network fault handling program can be used when one or more of these bits remains at 0.

The use of these system bits means that the state of COM words can be processed only after a network refresh. The user sets all remote station bits to 0 and monitors their change to 1.

Example

Stations 0, 1 and 2 are connected to the same network. Correct operation of stations 1 and 2 can be performed from station 0 as shown below:

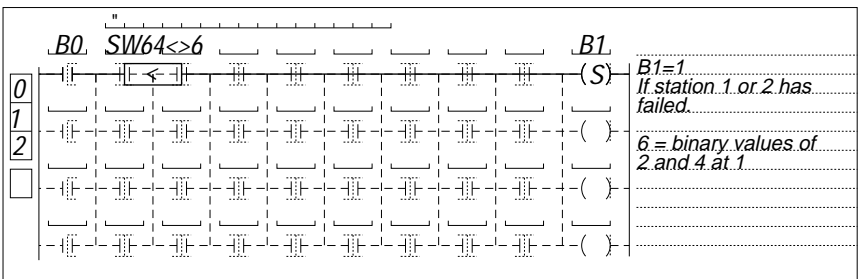
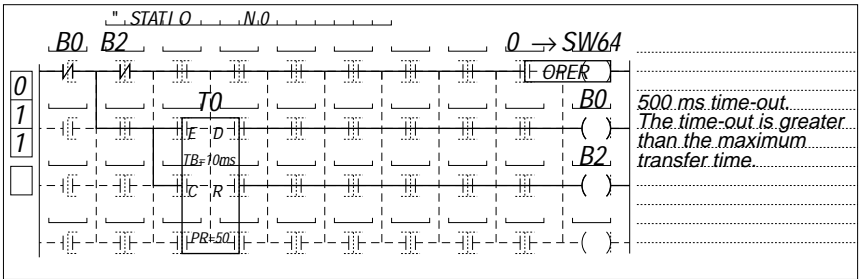

The TXT text block function exchanges data as word tables that are organized as shown below:

- A transmission table comprising internal words (Wi) or constant words (CWi),
- A reception table comprising internal words (Wi) that allow the destination station to store the data received.

TXTi,D: This bit goes to 1 when the text block completes its exchange (refer to sub-section 3.3),

TXTi,E: This bit goes to 1 if an exchange error occurs (refer to sub-section 3.3),

TXTi,S: This word comprises the number of bytes received in the reception table of the text block if the exchange is correct. If an exchange error occurs, TXTi,S takes the following values:

- 1: Exchange cancelled by Reset,
- 2: Transmission table length error,
- 3: Mains failure (refer to sub-section 3.3),
- 4: Module failure,
- 5: Parameter error or too many active TXTs,
- 6: Message received is too long,
- 10: Incorrect addressing of the indirect text block,
- 12: Message refused (refer to TXTi,V),
- 13: Routing error,
- 14: Resource error,
- 20: Other error.

TXTi,V: If parameter TXTi,S is set to 12 (message refused), word TXTi,V indicates the type of refusal:

- 1: Inadequate bus resources,
- 2: Inadequate line resources,
- 3: Cannot access destination,
- 4: Line error,
- 5: Length error,
- 6: Network failure,
- 7: Address error,
- 8: Unknown request code,
- 9: Inadequate PLC resources,
- 10: Time-out exceeded,
- 255: Other error.

TXTi,A: Comprises the destination address (network, station), in the form:

TXTi,A = H'	Network Nbr.	Station Nbr.
	1 byte	1 byte

If the messages are broadcast to all stations on the same network segment (broadcast messages), the station number is set to H'FF'. Transmission of broadcast messages to the entire network layout is not possible.

The reception table length is set when the text block is configured. It cannot be changed by the user program.

The address of the word table to send and of the reception table where the words received are stored can be specified in two ways:

- By direct addressing: the address is the first word of the table,
- By indirect addressing: the address is stored in a table,

Direct addressing

The text block reception table is stacked on top of the transmission table as shown below. The start address (Addr. Buffer) and the length (Reception length) of the table that is formed, are defined when the text block is configured.

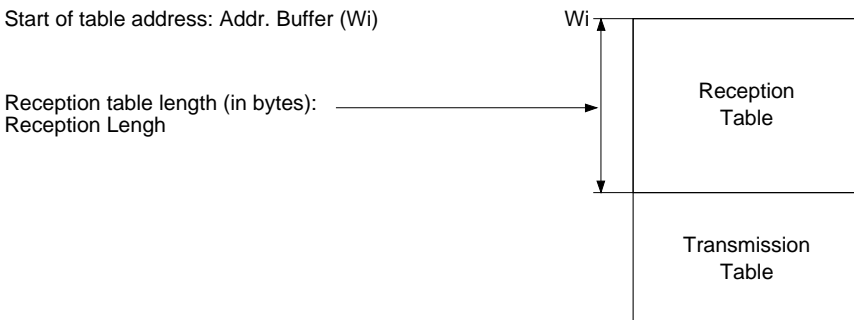

The transmission table length is defined by the user program, in variable $TXT_{i,L}$ of the text block. It can be changed during program execution.

Example

Text block number TXT_0 ,
 Start of table address: W_{10} ,
 Reception table length: 12 bytes,
 Transmission table length: $TXT_0, L = 8$ bytes.

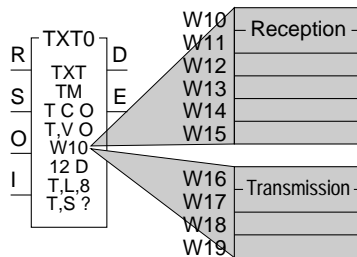

Special cases

When the text block is only used to send data:

- The reception table length can be null,
- The start of table address (Addr. Buffer) is also the transmission table address,
- The table can be located in the internal words (W_i) or in the constant words (CW_i).

Indirect addressing

The text block transmission and reception tables are defined by a six word addressing table that must be loaded with the information listed below:

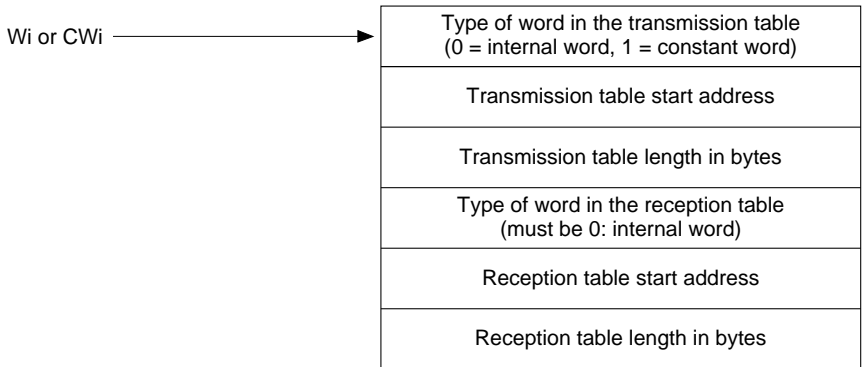

Only the start address (Wi or CWi) of the addressing table must be defined when the text block is defined.

Example

Text block TXT1, Indirect addressing, Addr. Buffer = W20.

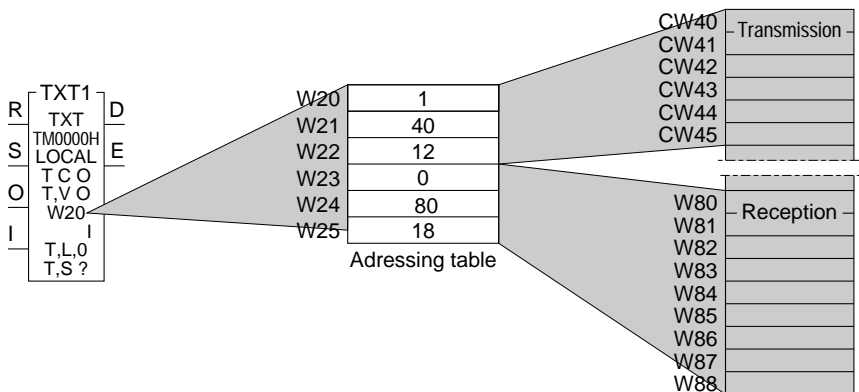

The addressing table defines the transmission and reception tables. It is composed of internal words W20 to W25 which contain the following information:

- W20: Indicates the type of words in the transmission table: 1 = Constant words,
- W21: Indicates the address of the transmission table: 40 → CW40,
- W22: Indicates the transmission table length: 12 bytes or 6 words. The last word in the transmission table is therefore constant word CW45,
- W23: Indicates the type of words in the reception table: 0 = Internal words,
- W24: Indicates the address of the reception table: 80 → CW80,
- W25: Indicates the reception table length: 18 bytes or 9 words. The last word in the reception table is therefore internal word W88.

2.3-3 Communication by SYS Text Block

The system (SYS) text block is used to communicate with certain system functions of a device connected to Mapway (PLCs or other vendor's device). This type of communication uses Uni-TE requests.

SYS text blocks comprise:

- A text block number TXTi,
- An exchange type SYS,
- A communication type Network (NET),
- A start of table address e.g. W10,
- A reception table length e.g. 4 bytes,
- A transmission table length TXTi,L (in bytes),
- Uni-TE request code TXT,C,
- An exchange report TXTi,V,
- A destination address TXTi,A.
- A status word TXTi,S,
- Input bits:

Start transmission	Literal Language	Ladder Language
Start reception	OUTPUT TXTi	S, O = 1,
Start transmission and reception	INPUT TXTi	S, I = 1,
Cancel exchange	EXCHG TXTi	S, I, O = 1,
	RESET TXTi	R = 1,
- Output bits:

Exchange complete	TXTi,D
Exchange error	TXTi,E

Parameters TXTi,D; TXTi,E; TXTi,A; TXTi,S and TXTi,V have the same meanings as those in TXT type text blocks.

TXTi,C: Comprises the code of the request to execute, in the form:

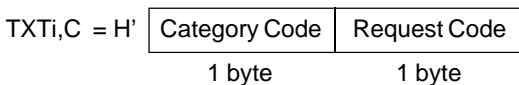

The category is that of the source. It takes the value 07. The other codes are reserved.

The request code is that of the request used (refer to the list of Uni-TE requests in the Appendix).

The request data is located in the text block transmission table. The report is located in the reception table if the text block was programmed in EXCHG.

TXTi,V: This word comprises the code written by the system, indicating exchange validity.

All other programming is performed in the same way as a TXT text block. The other bits and words have the same meaning.

Example

TxTi,A = H'0105' corresponds to a destination station at address 5 on network 1,
 TxTi,C = H'0706' corresponds to a PLC sending the "read system word" request
 (request code H'06').

2.3-4 Table Layout

The relations that exist between the structure of a report request and the parameters of a text block are:

Transmission

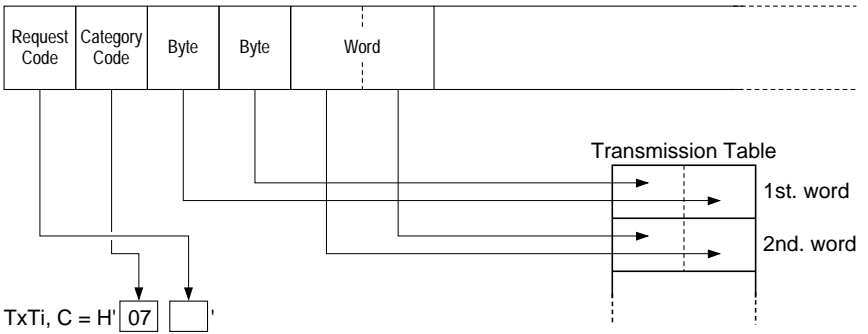

Reception

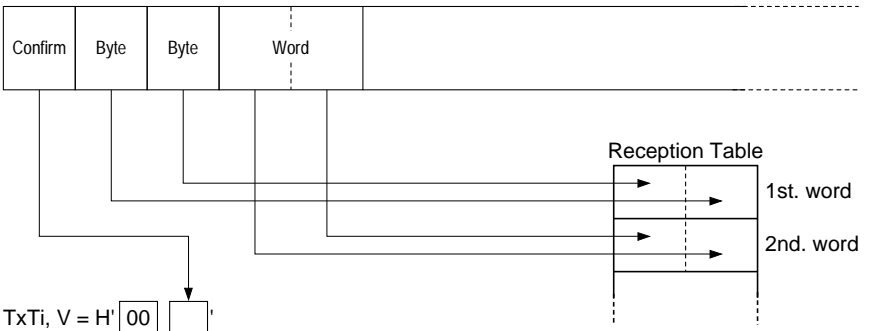

2.4 Uni-TE Services

2.4-1 General

Reminders

This service uses a question and answer dialog called Request/Confirm.

A device that supports the Uni-TE protocol can be a:

CLIENT: This device initiates communication. It asks a question (reads), sends an answer (writes) or an order (Run, Stop, etc.),

SERVER: This device executes the order sent by the client and sends a confirm after execution.

The services supported depend on the type of device, e.g. PLC, numerical controller, programming terminal, supervision system. Depending on its function, each device can be a Client and/or a Server on the Mapway network. Server functions include supporting Programming, Adjust and Debug functions while Client functions include the user program sending commands or reading the state of a device.

The rate at which Uni-TE requests can be handled by a PLC depends on the Master task cycle.

Regardless of where in the program a text block is activated, the PLC processor sends the appropriate request at the end of the PLC cycle.

A check is made at the start of each cycle to determine if a confirm was received for the request.

While the Master task is running, the PLC can send and receive two TXT, SYS or TLG messages over Mapway in normal operation and up to four messages in peaks.

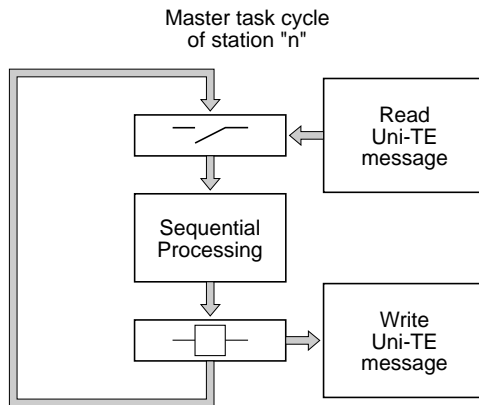

2.4-2 Server PLC

A PLC is a server when it responds to requests sent by a client device, e.g. another PLC, a Monitor 77 supervisor, an FTX 507 workstation or a computer. The request is generated by the source and sent to the system gate of the destination PLC.

In this case, the exchange can comprise up to 128 characters and is fully transparent to the application program of the server PLC.

The requests that are supported PLCs are listed in the table below. The detailed coding of these requests is given in the Appendix.

Family	Service	Request		Confirm		Description
		Hex.	Dec.	Hex.	Dec.	
Data (Read)	Read a Bit	00	00	30	48	Reads a bit (B).
	Read a Word	04	04	34	52	Reads a word (W).
	Read Objects	36	54	66	102	Reads objects (bits, words, word strings, etc.).
	Read a System Bit	01	01	31	49	Reads a system bit (SY).
	Read the Memory Image of an I/O Bit	02	02	32	50	Reads the memory image of an I/O bit.
	Read a Constant Word	05	05	35	53	Reads a constant word (CW).
	Read a System Word	06	06	36	54	Reads a system word (SW).
	Read a Common Word	07	07	37	55	Reads a common word (COM).
	Read a Timer	09	09	39	57	Reads the parameters of a timer (T).
	Read a Monostable	0A	10	3A	58	Reads the parameters of a monostable (M).
	Read a Counter	0B	11	3B	59	Reads the parameters of a counter (C).
	Read a Register	0E	14	3E	62	Reads the parameters of a register (R).
	Read a Grafcet Step	2A	42	5A	90	Reads a Grafcet step (Xi).
	Read a Double Word	40	64	70	112	Reads a double word (DW).
	Read a Constant Double Word	41	65	71	113	Reads a constant double word (CDW).
Read a Grafcet Step	4B	75	7B	123	Reads a Grafcet step.	

Family	Service	Request		Confirm		Description
		Hex.	Dec.	Hex.	Dec.	
Data (Write)	Write a Bit	10	16	FE	254	Writes a bit (B).
	Write a Word	14	20	FE	254	Writes a word (W).
	Write Objects	37	55	FE	254	Writes objects (bits, words, bit or word strings, etc.).
	Write a System Bit	11	17	FE	254	Writes a system bit (SY).
	Write the Memory Image of an I/O bit	12	18	FE	254	Writes the memory image of an I/O bit.
	Write a System Word	15	21	FE	254	Writes a system word (SW).
	Write a Common Word	16	22	FE	254	Writes a common word (COM).
	Write a Timer Preset	17	23	FE	254	Writes the preset of a timer (T).
	Write a Monostable Preset	18	24	FE	254	Writes the preset of a monostable (M).
	Write a Counter Preset	19	25	FE	254	Writes the preset of a counter (C).
	Write a Register Input	1A	26	FE	254	Writes the input of a register (R).
	Write a Double Word	46	70	FE	254	Writes a double word (DW).
Operating Modes	Run	24	36	FE	254	Sets a device to Run.
	Stop	25	37	FE	254	Sets a device to Stop.

Note: Other requests are supported by PLCs. These requests are used for specific applications and are not covered in this manual.

2.4-3 Client PLC

A Client PLC sends data, an order or a question using Uni-TE requests.

The request is sent to the target station by a SYS type Network text block with a maximum length of 128 bytes.

The requests that can be sent by the PLC are:

- The requests described previously (for dialog between PLCs),
- The requests supported by a destination station that is not a PLC, e.g. CNC, MicroVAX computer. For further information refer to the documentation for the individual devices giving their coding.

Example

In the network shown below (network 1), the PLC at address 4 reads the parameters of timer T10 of the PLC at address H'0F'. The PLC at address H'0F' does not require a specific application program to allow the station access to its system.

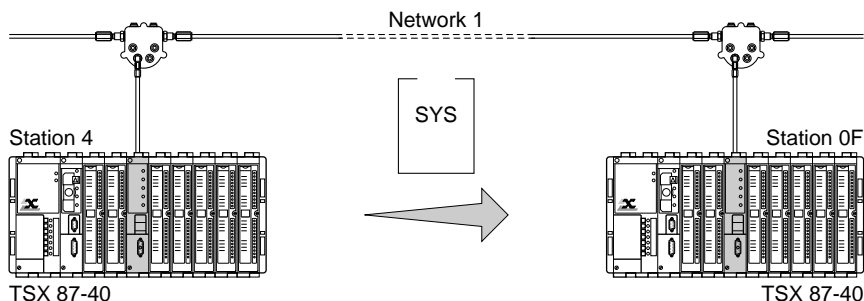

Data

- Read timer request:
 - Request code = H'09' (see list of requests),
 - Parameter = Number of the timer to read.
- Text Block:
 - The request is sent by text block TXT5 of the application program in station 4,
 - Start of transmission table = W264. The transmission table comprises the number of the timer (10),
 - Start of reception table = W200.

Transmission

- Station 4 Text block:

- TXT5 is a SYS type Network text block,
- TXT5,A = H'010F' Network 1, Target station H'0F',
- TXT5,C = H'0709' Category code = H'07', Request code = H'09',
- TXT5,L = 2 (Length of the transmission table in bytes),
- Transmission table:

Timer number W264

10

Reception

- Station 4 Text block:

- TXT5,V = H'39' Correct exchange confirm,
- TXT5,D = 1,
- TXT5,E = 0,
- TXT5,S = 8 8 bytes received,
- Reception table:

W200	00	02
W201	01	01
W202	3600	
W203	1712	

- Confirm analysis:**

W200 = H'0002'

Least significant byte = 02 → 1 second time-base,

Most significant byte = 00 → time-base not timed out.

W201 = H'0101'

Least significant byte = 01 → timer running,

Most significant byte = 01 → preset can be changed.

W202 = 3600

The configuration preset value is 3600.

W203 = 1712

The current value when processing took place was 1712.

Read objects request

This request allows the reading of simple objects (words, word strings, etc.). It is described in detail in the Appendix.

When this request is sent, the user must specify the parameters of the source text block (TXTi,C; TXTi,L, etc.) and its transmission table. The transmission table includes the following parameters:

- Segment that the request is addressed to,
- Type of object to read,
- Address of the first object to read,
- Number of objects to read.

Once the request is processed by the destination device, it sends the type of object read and the requested information back to the start of the source text block.

The source text block reception table (when set to read words for example) has the following layout:

Wi	1st. word LSB	Type of object
Wi+1	2nd. word LSB	1st. word MSB
Wi+2	3rd. word LSB	2nd. word MSB
Wi+3	etc.	3rd. word MSB

Data received is shifted by one byte and is stored in two consecutive words. The application program must therefore take into account the shift when processing the data received. This is done:

- By the SLCWORD (Source;Length) instruction in TSX Series 7 Model 40 PLCs,
- By program in TSX Series 7 V3 PLCs.

Example

The PLC at address 4 reads a table of 20 words (starting at address W50) from a PLC at address H'0F'.

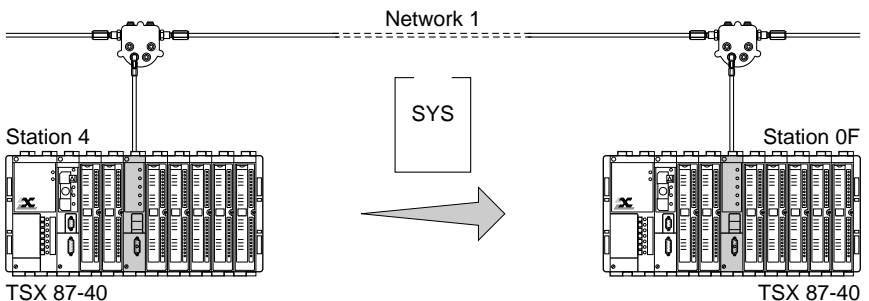

Data

- Read objects request = H'36' refer to list of requests,
- Parameter: Segment nbr. = H'68' (internal words),
 - Type of object = H'07' (16-bit integers),
 - Start address = 50,
 - Nbr. of objects to read = 20.
- Text block:
 - The request is sent by text block TXT2 of the application program in station 4,
 - Start of transmission table : W364,
 - Start of reception table : W300.

Transmission

- Station 4 text block
 - TXT2 is a SYS type Network text block,
 - TXT2,A = H'010F' network 1, destination address H'0F'
 - TXT2,C = H'0736' category code = H'07', request code = H'36'
 - TXT2,L = 6 (transmission table length in bytes),
 - Transmission table:

Type (H'07') / segment (H'68')

Address of the first word to read

Number of words to read

W364	07	68
W365	50	
W366	20	

Reception

- TXT2,V = H'66' (correct exchange confirm),
- TXT2,D = 1
- TXT2,E = 0,
- TXT2,S = 41 (receive 41 bytes).

As the data is shifted by one byte, the application program uses the SLCWORD (W300;W400) instruction to shift the data again. W400 represents the length (in bytes) of the processing. In this example, W400 must contain the value 41. Once the operation has been performed, the reception table is laid out as follows:

W300	W50 MSB	W50 LSB
W301	W51 MSB	W51 LSB
W321	W69 MSB	W69 LSB

2.5 Application-to-Application Communication

2.5-1 Point-to-Point Messages

The TSX MAP 1074 module supports point-to-point message exchange on Mapway. A PLC connected to Mapway can:

- Send a message to another PLC when requested to do so by its application program,
- Receive a message from another PLC.

These messages are sent to their destination by a TXT type Network text block with a maximum size of 256 bytes. They are received by the destination PLC using a TXT type Network text block.

The messages are contained in the transmission and reception tables of the text blocks.

Logical connection between the two stations requires simultaneous:

- **Transmission activation** (OUTPUT TXTi) of a text block by the application program of the source station, and
- **Reception activation** (INPUT TXTi) of a TXT type Network text block by the application program of the destination station.

The text block parameters are:

TXTi,A: TXTi,A of the source station text block comprises the network and station numbers of the destination station.

TXTi,A of the destination station text block comprises the network and station numbers of the source station.

TXTi,T: TXTi,T of the source station text block comprises the number of the destination station text block.

TXTi,T of the destination station text block comprises the number of the message source text block.

Regardless of where in the program a text block is activated, the PLC processor sends the appropriate request at the end of the PLC cycle.

While the Master task is running, the PLC can send and receive two messages via Mapway in normal operation and up to four messages during peaks.

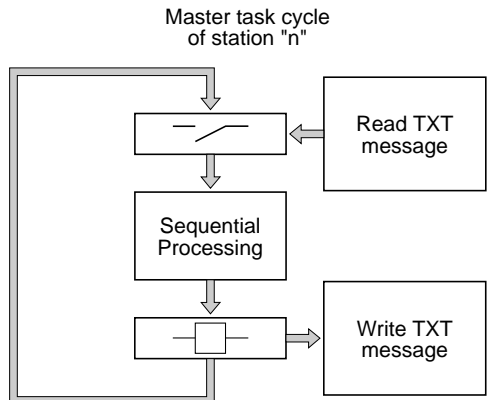

Parameter programming example

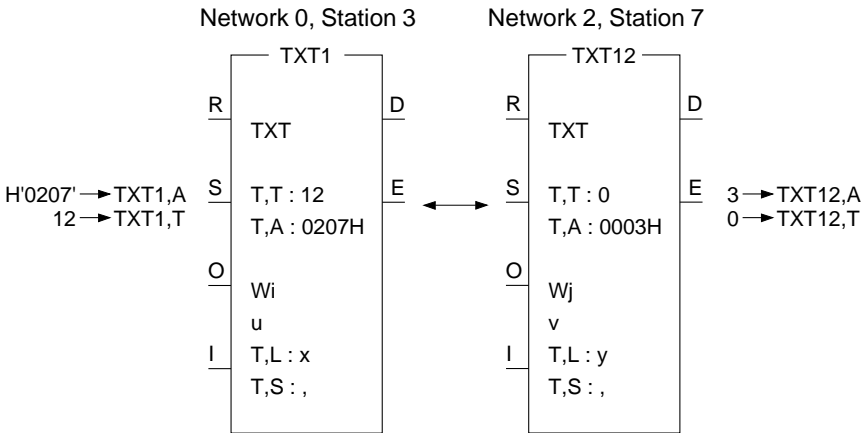

2.5-2 Broadcast Messages

A broadcast message is a point-to-point message that is sent to all stations on the same network.

A broadcast message is read by all other stations on the same network as the source station, on condition that they have a text block configured to receive these messages.

TXTi,A: Comprises the network and station numbers of the destination stations. The station number takes the value H'FF'.
E.g. H'01FF' for all stations on network 1.

TXTi,T: Gives the number of the destination station text block. All text blocks configured to receive broadcast messages must have the same number.

The other parameters must be initialized in the same way as a point-to-point text block.

Remember to ensure that each destination station has a text block configured for reception (INPUT TXTi) with the number of the message source text block in its TXTi,T parameter.

All of the rules that apply to text block programming apply to broadcast messages.

2.5-3 Point-to-Point Message Example

In the example shown below the TSX 87-40 PLC at address H'0204' (Network 2, Station 4) sends the message "HIGHER THRES REACHED" to the TSX 47-40 PLC at address H'010C' (Network 1, Station H'0C').

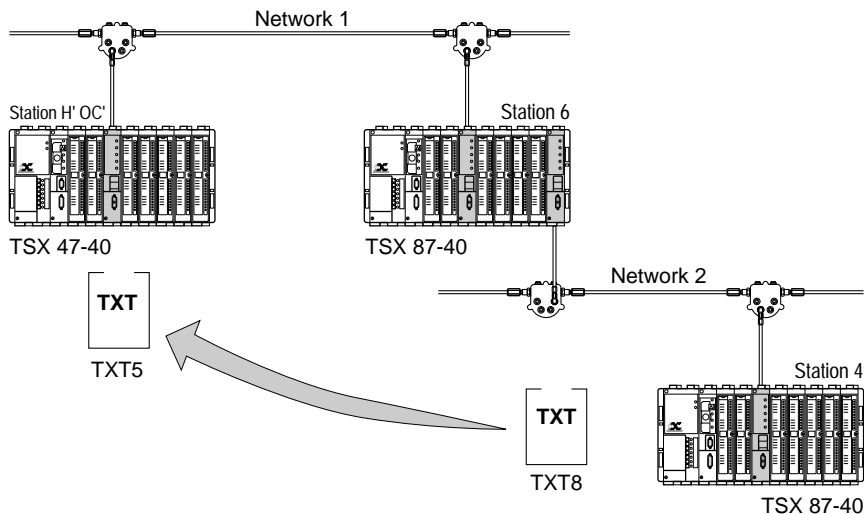

Data

- Source PLC (Network 2, Address 4):
 - The message is sent by text block TXT8 of the application program,
 - Start of transmission table = W100. The transmission table comprises the message to send,
 - There is no reception table.
- Target PLC (Network 1, Address H'0C'):
 - The message is received by text block TXT5 of the application program,
 - Start of reception table = W10,
 - There is no transmission table.

Message transmission

- Text block:
 - TXT8 is a TXT type Network text block set for OUTPUT TXTi,
 - TXT8,A = H'010C' Network 1, Target address H'0C',
 - TXT8,T = 5: Text block TXT5 is the destination,
 - TXT8,L = 20: Send 10 words (20 bytes),
 - W100 = Reception table address W100 corresponds in this case to the address of the transmission table as the reception table length is zero.

- Transmission table:

W100	49 (I)	48 (H)
W101	48 (H)	47 (G)
W102	52 (R)	45 (E)
W103	54 (T)	20 (Space)
W104	52 (R)	48 (H)
W105	53 (S)	45 (E)
W106	52 (R)	20 (Space)
W107	41 (A)	45 (E)
W108	48 (H)	43 (C)
W109	44 (D)	45 (E)

Message reception

- Text block:
 - TXT5 is a TXT type Network text block set for INPUT TXTi,
 - TXT5,A = H'0204' Network 2, Source station H'04',
 - TXT5,T = 8: Text block TXT8 is the source,
 - TXT5,L = 0: Transmission table length is zero,
 - W10 = Reception table address,
 - Reception table:

W10	49 (I)	48 (H)
W11	48 (H)	47 (G)
W18	48 (H)	43 (C)
W19	44 (D)	45 (E)

- TXT5,S = 20: Receive 20 bytes (10 words).

2.6 Priority Communication - Telegram

2.6-1 General

Note: The telegram service is only supported by TSX Series 7 Model 40 PLCs.

A telegram is a specific type of text block used for priority transmission of short messages (up to 16 bytes max.) between two stations. It can be used by any task in the sender PLC (Master task, fast task or interrupt task) and can be sent to any station on the same network.

When a telegram is sent, the PLC processor immediately sends the message to the network interface module, without waiting for the end of the Master task cycle.

In reception, as soon as the message is received by the network interface module, an interrupt is generated and sent to the PLC processor. The destination application interrupt task (IT task) then reads the telegram and performs any required actions. This process usually ensures application program-to-application program communication in less than 30ms.

A telegram is sent by a TLG type Network function block. An application program can only send one telegram in each cycle to each network interface. A PLC that comprises a number of network interfaces (e.g. in Bridge or data concentrator applications) can simultaneously send a telegram from each network interface.

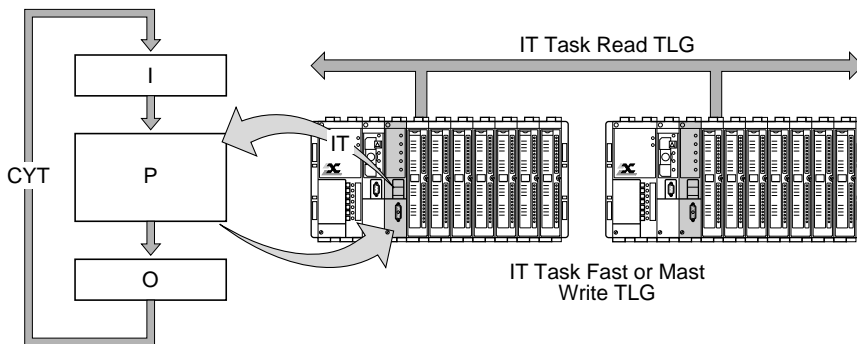

TLG text block parameters

The "TLG" text block function comprises the following parameters. They must be defined on configuration:

- | | |
|-----------------------------|------------------------|
| • Text block number | TXTi |
| • Type of exchange | TLG |
| • Type of communication | NET |
| • Start of table address | e.g.: W10 |
| • Reception table length | 16 bytes max. |
| • Transmission table length | TXTi,L (16 bytes max.) |
| • Type of addressing | Direct or Indirect |

The TLG text block also comprises:

	Literal	Ladder
• Input bits:		
Start "Transmission"	OUTPUT TXTi	S,O = 1
Start "Reception"	INPUT TXTi	S,I = 1
Start "Transmission-Reception"	EXCHG TXTi	S,I,O = 1
Cancel exchange	RESET TXTi	R = 1
• Output bits:		
"Exchange complete"	TXTi,D	
"Exchange error"	TXTi,E	
• Status word	TXTi,S	
• Target address	TXTi,A	
• Target text block number	TXTi,T	

TXTi,S

The status word (TXTi,S) comprises the number of bytes sent or received (1 to 16) by the text block by its transmission or reception table when the exchange is correct. If an exchange error occurs, (bit TXTi,E at 1), TXTi,S takes one of the values listed below:

- 1 : Exchange in progress cancelled by Reset,
- 2 : Message longer than 16 bytes (in transmission),
- 3 : Power failure,
- 4 : Module failure,
- 6 : Telegram too long for the text block reception buffer,
- 10 : Incorrect text block parameters for indirect addressing,
- 13 : Routing error (cannot access network),
- 14 : System reconfiguring, module self-testing, etc.,
- 15 : Telegram channel busy (in transmission).

This variable can only be read and is significant only when the exchange is completed.

TXTi,A

The destination address (TXTi,A) must be coded as:

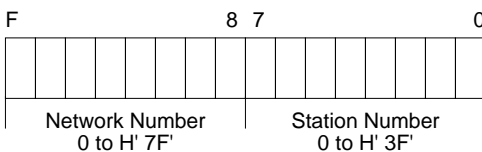

Note: Parameters TXTi,L; TXTi,A and TXTi,T can be modified by program.

2.6-2 Telegram Programming

Transmission

The transmission of a telegram (TLG) type text block is programmed in the same way as a TXT type text block.

Transmission is started when input "O" is set to 1 in Ladder language or with the OUTPUT TXTi instruction in Ladder. The TLG text block can be started from the application program interrupt task, fast task or master task.

If transmission is unsuccessful, e.g. the destination PLC is powered-down, no TLG text block is configured in Input, the telegram that was sent is returned to the sender Mapway interface. This interface will then generate an interrupt. If an IT task is running and enabled (DMASKINT), it is executed. The IT task must be acknowledged (ACKINT) or the PLC will generate a MEM error condition and stop the application.

The use of TXTi,E and TXTi,D bits is described in sub-section 3.3, Data-Rate Control.

Reception

A telegram is received by a TLG type text block.

The telegram destination network interface must know which text block is ready to receive the message. To ensure this, the text block must be set-up as INPUT TXTi.

On reception of a telegram from the network, the network interface gives it priority, reads it and generates an interrupt that is sent to the PLC processor. The interrupt starts the application program interrupt task that must:

- Determine which network interface generated the interrupt,
- Read the telegram with the "READTLG" instruction.

The network interface that generated the interrupt is determined by the instruction:

READINT (Ixy;Bi)

x = Rack number (0),

y = Module position in the rack (0 to 7),

Bi= Copies the interrupt from the module to an internal bit. This bit goes to 1 when an interrupt is detected.

The telegram is read by the instruction:

READTLG (Ixy;Wi)

x = Rack number (0),

y = Module position in the rack (0 to 7),

Wi = Read confirm that takes one of the following values:

- 0 : Reception successful,
- 4 : Message longer than 16 bytes (in reception),
- 5 : Incorrect destination address,
- 6 : Reception network interface error,
- 7 : Communication system reconfiguring,
- 8 : Telegram reception already in progress,
- 9 : No telegram waiting,
- 10 : No TSX MAP 1074 module,
- 11 : TSX MAP 1074 but not supported,
- 12 : Telegram reception refused,
- 13 : No TLG text block configured in Input,
- 14 : Telegram received with an bad check character (BCC),
- 15 : Telegram channel busy.

Execution of this instruction copies the message to the reception buffer of the TLG text block, sets the text block "D" bit to 1 and updates word Wi. The telegram is then available for reading and all related actions.

Transmission - Reception

A TLG text block can be programmed for transmission/reception by the EXCHG TXTi instruction (or by setting bits S, I, O to 1). Responding to the text block is up to the application program of the destination PLC. This response must be sent by a TLG text block program for OUTPUT. Data reception is performed as described above (interrupt detection and telegram reading). The data received is stored in the reception table of the text block.

2.6-3 Telegram Example

Transmission from the TSX 67-40 PLC at address H'0204' (Network 2, Station 4) of the message "ALARM 8" to the PLC at address H'020C' (Network 2, Station H'0C'):

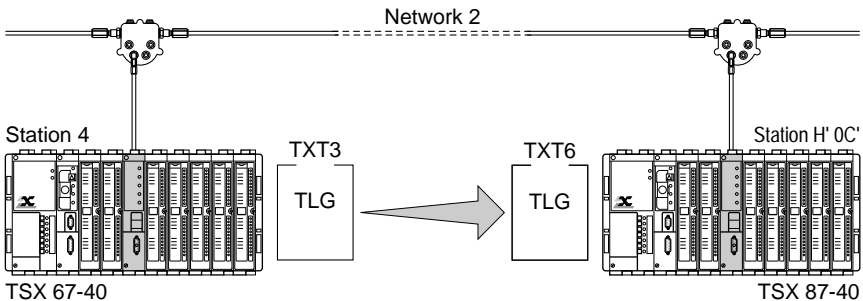

Data

- Source PLC (Station 4):
 - The telegram is sent by application program text block TXT3,
 - Start of transmission table = W100. The transmission table comprises the message to send,
 - There is no reception table.
- Target PLC (station H'0C'):
 - The message is received by application program text block TXT6,
 - Start of reception table = W50,
 - Reception table length: 16 bytes,
 - There is no transmission table.

Message transmission

- Text block:
 - TXT3 is a TLG type Network text block programmed for OUTPUT,
 - TXT3,A = H'020C' destination address (Network 2, Station H'0C'),
 - TXT3,T = 6 : TXT6 is the destination text block,
 - TXT3,L = 8 : Send 8 bytes,
 - W100 = Reception table address. As there is no reception table (nul length), W100 corresponds to the transmission table address.
 - Transmission table.

W100	4C (L)	41 (A)
W101	52 (R)	41 (A)
W102	20 (space)	4D (M)
W103	20 (space)	38 (8)

- Telegram transmission
The telegram is sent from the master task:

```
< Transfer data to the transmission table
! W152[4] → W100[4]
```

```
< Send telegram
! OUTPUT TXT3
```

Message reception

- Text block:
 - TXT6 is TLG type Network text block programmed in INPUT,
 - TXT6,A = H'0204' source address (Network 2, Station 4),
 - TXT6,T = 3: Text block 3 is the source,
 - Recept. length = 16: receive 16 bytes max.,
 - W50 = Reception table address,
 - There is no transmission table, TXT6,L = 0.

The telegram destination module is located in Rack 0, Slot 2. The message is received in two steps:

- Master task:

```
< Activate IT task
! Start CTRL 1

< Validate interrupts
! DMASKINT (I 02)

< Set text block TXT6 to receive
! INPUT TXT6
```

- Interrupt task:

```
< Read the module interrupt
! READINT (I02;B14)

< If interrupt bit (B14) is present, read the telegram
! IF B14 THEN JUMP L10

< Continue program
! .....

< Read telegram
! L10: READTLG (I02;W45); RESET B14

< Analyze correct read confirm
! IF [W45 = 0] then jump L20

< Process errors (analyze W45)
! [IF W45 = ...] THEN .....
.....

< Number of bytes received and stored in word W30
! L20: TXT6,S → W30

< Process data received
! W50[W2].....
.....
```

2.7 PLC Scan Cycle

The diagram opposite shows the Master task cycle of the PLC where the TSX MAP 1074 module is located.

The only information indicated is that which is absolutely necessary to understand the operation of the TSX MAP 1074 module.

- ① Process system bits and words and update them when they are set by the system.
- ② Monitor various parameters including the presence of the TSX MAP 1074 module and if necessary act on the fault bits lxy,S; SY10, etc.
- ③ Write data to memory for the COM words that have changed in other stations and up to four messages.
- ④ Execute the user program.
- ⑤ Send the COM words assigned to this station that have been changed and up to four messages, to the TSX MAP 1074 module.

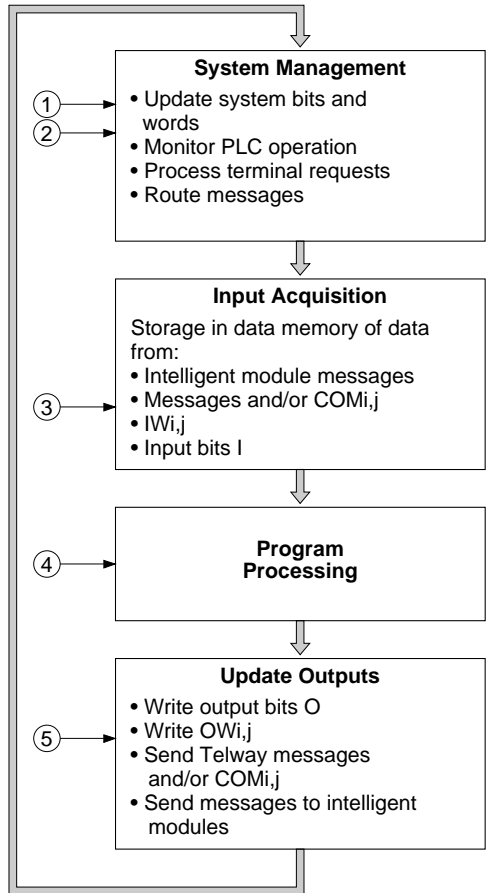

Important

Each master task cycle can process in transmission and reception:

- COM words (up to 64 max.),
- Up to four messages at peak network load.

The sum total of all input and output messages (COM + TXT, SYS or TLG type text blocks) cannot exceed 200 messages per second.

To avoid overloading the PLC in normal operation, no more than two messages per cycle should be exchanged.

2.8 Multiple Network Configurations

2.8-1 Module Configuration

In a multiple network configuration (Mapway and/or Telway), there are three possible cases:

- The network interface is in a station that is at the end of a network drop (stations 1.a, 1.b, 1.c, 2.b, 2.c, 3.b),
- The network interface is in a station that comprises more than one network connected to different networks without being a network bridge (station 1.e/3.a),
- The network interface is in a station that is a network bridge (station 1.d/2.a).

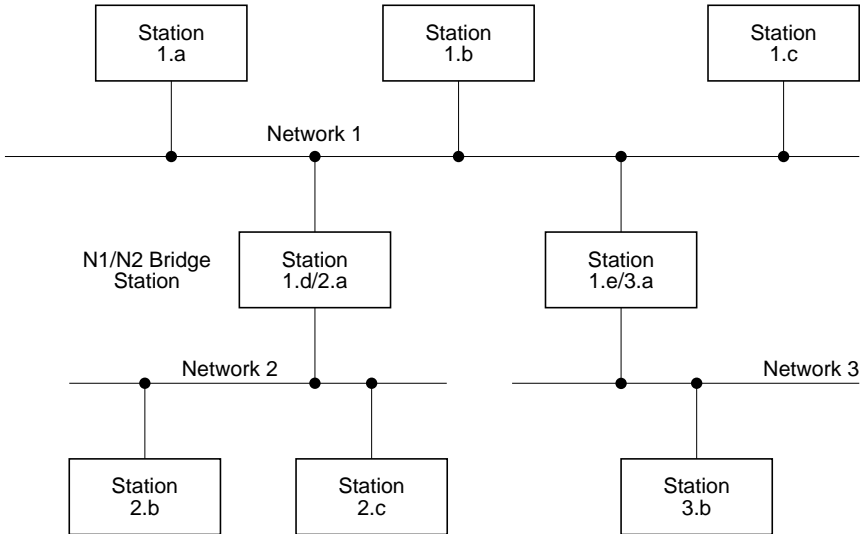

In the first two cases there is no need to configure the network interface modules. All of the routing information is held by the bridge station on the network to which they are connected.

In the last case (bridge PLC), the network interfaces must be configured.

A network bridge station is configured with PL7-NET software. PL7-NET is an X-TEL Software Workshop option.

The following operations must be performed:

- Description of the entire network layout and entry of the name and number (0 to H'7F) assigned to each network,
- Selection of the stations that form a network and assignment of station addresses (0 to H'3F'),
- Network interconnection by selection of bridge PLC stations,
- Assignment in each bridge of modules to the different networks,
- Storage of network layout information on disk. For each bridge, this file contains a complete list of the networks it serves,
- Transfer of this file to all of the bridge stations in the network layout.

For more information on the use of this program, refer to the PL7-NET User's Manual, TXT DM PL7 NET V4E.

2.8-2 PLC Cycle Time

The master task cycle time of a bridge PLC depends on the type of networks connected (Mapway to Mapway or Mapway to Telway bridge).

Reminders on PLC scan cycles

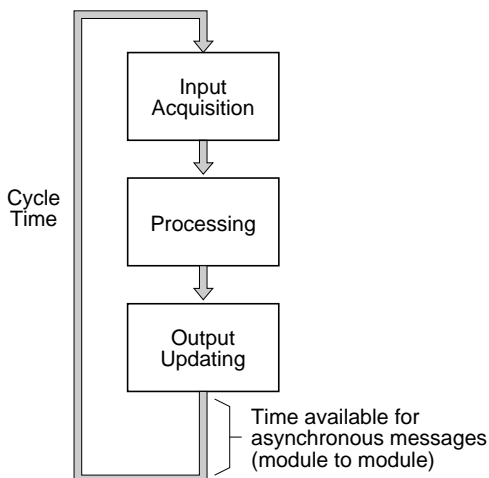

Mapway to Mapway bridge PLC

Data routing is performed in the field reserved for the asynchronous message system.

The time reserved for message system processing (message transfer between segments) corresponds to the cycle time less the application program processing time.

To improve performance of a Mapway to Mapway bridge PLC, it must have the following characteristics:

- A long cycle time,
- No sequential processing,
- No COM word management.

Example: A bridge PLC with a 200 ms cycle time and no sequential processing will make approx. 195 ms, or 97% of its cycle time available to message system processing.

Mapway to Telway bridge PLC

Data routing is performed when outputs are updated (synchronous message system) at the rate of one message per cycle.

The time reserved for updating outputs is defined by the PLC system and cannot be modified by the user.

To improve performance of a Mapway to Telway bridge PLC, it must have the following characteristics:

- A short cycle time,
- No sequential processing,
- No COM word management.

Example: A bridge PLC with a 10 ms cycle time and no sequential processing will be able to route a message every 10 ms.



Sub-section	Page
3.1 Troubleshooting	54
3.1-1 General	54
3.1-2 LED Indicators	54
3.1-3 LED Displays	56
3.1-4 Troubleshooting Using the LED Indicators and Displays	57
3.2 Self-Tests and Specific Tests	59
3.2-1 Starting the Self-Tests	59
3.2-2 Starting the Specific Tests	60
3.3 Data-Rate Control	62

3.1 Troubleshooting

3.1-1 General

The front panel of TSX MAP 1074 modules comprises five indicator LEDs and two seven segment LED displays.

These indicators and displays are used to display important information on the operation of the module and its connection to the Mapway network.

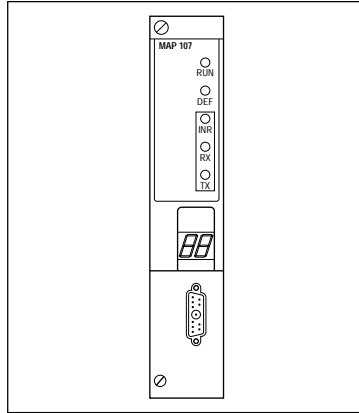

3.1-2 LED Indicators

The “RUN” LED

This green LED indicates the general condition of the module. It is lit when the module is operational and active. It is extinguished when the module is not operational.

When the module connects to the network and while the self-tests are in progress, this LED blinks. It remains lit when the self-tests have been successfully completed and during normal module operation. If a fault is detected it is extinguished and inhibits the module from becoming active.

This LED is hardware controlled. It is extinguished by the watchdog, triggered by a module failure.

The “DEF” LED

This red LED lights when a TSX MAP 1074 module fault occurs.

This LED lights briefly when the module is powered-up, it is extinguished when the self-test phase starts. It will only light again if:

- One of the tests performed during the self-test phase detects an error. The error code will be displayed by the seven segment LED displays (refer to sub-section 3.2-1),
- A permanent error is detected during normal operation,
- The TSX MAP ACC1 terminal block is disconnected from the module.

This LED is software controlled. When the internal software that controls the module, detects an operating fault that affects proper module operation, it lights the “DEF” LED. This LED does not automatically light when the “RUN” LED is extinguished.

The “INR” (IN Ring) LED

This yellow LED lights to indicate that the TSX MAP 1074 module is connected to the Mapway network and that it is active in passing the token on the bus.

It lights briefly when the module is powered-up and is extinguished when the self-test phase starts.

The last self-test checks the network, if at least one other station is connected. Once it has done this, it sends an “add station” request so that the newly powered-up module can obtain the token. If it is successful in adding the module to the network, the “INR” LED lights.

If for any reason, the module cannot connect to the network and gain access to the token, the “INR” LED will be extinguished.

This LED is software controlled. As long as it is extinguished, the station cannot send messages, it can only receive them.

Note: If the network number of a station is different than that of the other stations, its “INR” LED will remain lit (token passing is detected) but it will never be able to send on the network as the token is not addressed to it.

The “RX” and “TX” LEDs

These two yellow LEDs indicate that the TSX MAP 1074 module has detected data reception (RX) or transmission (TX) activity. These LEDs do not indicate token passing or control frames, only data transmission and reception to and from the individual station.

On initialization, these two LEDs light briefly, only to be extinguished by the start of the self-test procedure. They are software controlled.

3.1-3 LED Displays

The TSX MAP 1074 module comprises two seven segment plus decimal point LED displays.

When the module is powered-up a random value will be displayed and immediately cleared.

During the self-test phase, the displays show the number of the test in progress. If a fault is detected, the corresponding error code is displayed by the LEDs and the "DEF" LED is lit.

Once the self-tests have been completed successfully, the LEDs alternately display the network and station number of the module. The number of the network that the module is connected to is displayed first, with a decimal point in the lower right of the display. The station number assigned to the module is also displayed, without the decimal point.

In normal operation, the LEDs display the network address of the station as network number followed by the station number.
--

The station address display alternates cyclically over a period of approx. two seconds. This sequence allows network diagnostics in Local mode. A check can be performed to ensure that the network and station numbers are set correctly in the TSX MAP ACC1 terminal block.





As soon as a fault is detected during normal module operation, the "DEF" LED lights and the LEDs display the appropriate error code.

3.1-4 Troubleshooting Using the LED Indicators and Displays

The combined use of the indicator and display LEDs will identify a number of operating faults and their causes.

The table below lists the main faults that can be detected and the remedial action that should be taken.

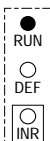
Before taking any action, the module should first be disconnected, reconnected and reinitialized to ensure that the fault persists.

Indicators	Probable Causes	Remedial Action
	<ul style="list-style-type: none"> LED failure Power supply failure 	<ul style="list-style-type: none"> Check supply to the station Change the power supply module
	<ul style="list-style-type: none"> Self-test fault (*) Permanent fault (*) 	<ul style="list-style-type: none"> Refer to the error code displayed
	<ul style="list-style-type: none"> Terminal block absent (**) Fault identified by an error code displayed 	<ul style="list-style-type: none"> Fit the terminal block Refer to the error code displayed
	<ul style="list-style-type: none"> Terminal block address error Station excluded from the logical ring Network failure 	<ul style="list-style-type: none"> Check the coding in the terminal code block Check network status
	<ul style="list-style-type: none"> PLC not connected 	<ul style="list-style-type: none"> Check the PLC
	<ul style="list-style-type: none"> Normal display during normal module operation 	

(*) Error code displayed; (**) "Eb" displayed

Note: The "TX" and "RX" LEDs are not shown in the above table as they are not used for troubleshooting the module.

List of error codes (other than self-test error codes)

If a fault is detected during normal operation or when a specific test is run (refer to sub-section 3.2), one of the values shown in the list below will be displayed.

Error code	Fault	Remedial Action
20	LCC initialization error (resource allocation, self-tests).	Reset the PLC (SY0 = 1).
21	Problem detected in normal operation (e.g. invalid data).	Reset the PLC (SY0 = 1).
22	Address duplicated on the same network.	Change the station code set in the terminal block.
23	Modem problem	Check that the module is correctly installed and its mounting screws tight. Reset the PLC (SY0 = 1) or cold restart.
31	Initialization problem during initialization phase.	Change the module.
41	Initialization problem in the COM protocol.	Change the module.
42	COM word reconfiguration problem	Change the module.
51	Initialization problem in the TSX Series 7 protocol.	Change the module.
Eb	Terminal block absent.	Fit the terminal block.

3.2 Self-Tests and Specific Tests

3.2-1 Starting the Self-Tests

Each time it is powered-up, the TSX MAP 1074 module runs a self-test sequence that comprises:

- Module micro-program checksum,
- Checking the RAM memory assigned to the microprocessor,
- Checking the logic of the shared memory used to exchange data with the PLC,
- Inserting the station into the network logical ring and token passing. Sending test frames to the previous and next stations on the network.

The self-tests are triggered after the coded value (network and station numbers) is acquired by the TSX MAP ACC1 terminal block.

While the self-tests are in progress, the numbers of the individual tests in progress are displayed on the seven segment LED displays.

If the self-tests are completed successfully, the module becomes active and the "RUN" and "INR" LEDs are lit.

Any fault that is detected is indicated by the "DEF" LED. The fault code is displayed on the seven segment LED indicators.

List of self-tests

There are eight classes of self-tests shown as "X_." on the LED displays (X takes a value from 1 to 8).

Normally, the number of each class of test will be displayed as the tests are performed. If a fault is detected, the complete two figure error code will be displayed.

The table below shows the complete list of errors with the values displayed during a normal test sequence.

Value displayed	Self-tests
1_.	Minimal self-test.
2_.	PLC bus interface (SMU) test.
3_.	PLC bus shared RAM test.
4_.	System ROM checksum test.
5_.	I/O Test.
6_.	Token Bus Controller (TBC) test.
7_.	Interrupt test.
8_.	Network test.

3.2-2 Starting the Specific Tests

The TSX MAP 1074 module comprises a system that supports the running of specific tests for maintenance purposes. The tests can be selected from the four thumbwheel switches in the TSX MAP ACC1 terminal block.

On power-up, the value coded in the terminal block is read. If the value corresponds to a network and station number, the module runs the self-test sequence and if it is successful, starts normal operation. If the value corresponds to a specific self-test, as listed overleaf, the module will run the corresponding test.

If the specific test runs correctly, the module loops back to the start of the test and runs it again. If the test is stopped before completion, the “DEF” LED will light and the LED displays will display a test number. The tests are listed overleaf.

Specific test coding

The tests are run after the “STAT” thumbwheel switches have been set to a value listed overleaf. The “NET” thumbwheel switches must be set to H'FF'.

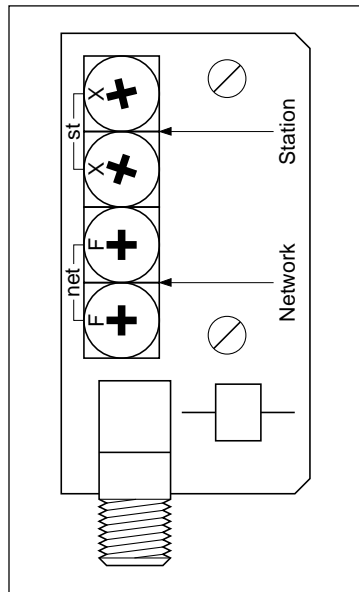

"STAT" Setting	Test Selected
FF	Continuous self-tests
FE	80186 register test
FD	512 KB RAM test
FC	Reserved
FB	PLC bus register test
FA	32 KB PLC bus interface RAM test
F9	256 KB checksum ROM test
F8	ROM type test
F7	Indicator LED test
F6	7 segment LED display test
F5	Status test
F4	Timer interrupt test
F3	Direct memory access interrupt test
F2	PLC bus interrupt test
F1	Reserved
F0	Token Bus Controller interrupt test
EF	Token Bus Controller reset init test
EE	CPU Token Bus Controller interface test
ED	Token Bus Controller loopback mode test
EC - E1	Reserved
E0	Permanent network test
DF - 80	Reserved
7F - 40	Reserved
3F - 00	Station Number

Error codes

If a fault is detected by a specific test, an error code is displayed by the module. The list of error codes is the same as that given in sub-section 3.2-1.

3.3 Data-Rate Control

Sending a text block changes the state of bits TXTi,D and TXTi,E. The possible values that these bits can take are:

Bit TXTi,D	Bit TXTi,E	Description
0	0	Exchange in progress
1	0	Exchange ended without error or no exchange
1	1	Exchange ended on error
0	1	Exchange not ended, exchange initially started on error

Power break or target disconnection

When a text block wired for EXCHG (or with inputs S, I and O at 1) sends a request, it is set to await a response and waits until it receives one. If a power failure occurs, or if the target station is disconnected, the source text block remains inhibited.

There are two possible cases:

Power break or target station disconnected during the exchange

Bits TXTi,D and TXTi,E remain at 0,

The application program of the source must take this case into account by including a "time-out" in the use of the source text block.

If no response is received before the time-out, then the text block should be reset to zero (Reset TXTi).

Power supply fault or disconnection of the target station before the exchange is started

The text block is set to error, bits TXTi,D and TXTi,E are set to 1 and the status word TXTi,S takes the value 3.



Sub-section	Page
4.1 Performance	64
4.1-1 Application-to-Application Transfer Time	64
4.1-2 Telegram Transfer Time	66
4.1-3 Request Transaction Time	68
4.1-4 Uploading Application Programs	70
4.1-5 Mapway-Mapway Bridge Processing Time	72
4.1-6 Mapway-Telway Bridge Processing Time	72

4.1 Performance

4.1-1 Application-to-Application Transfer Time

AAT: is the Application-to-Application Transfer time. This is the elapsed time from the moment a message is sent by the source station (START TXTi) till the moment it is received by the destination station (DONE bit processed by the application program).

Example

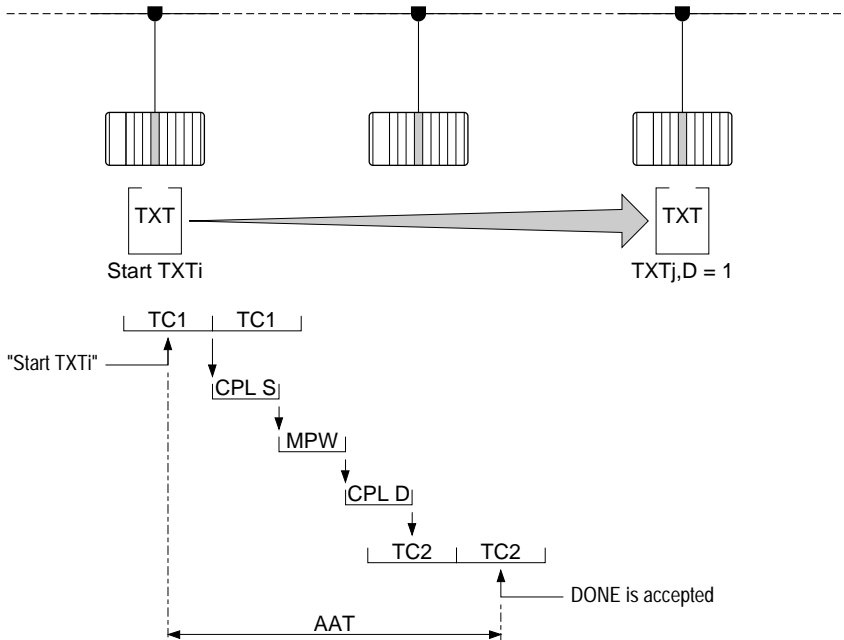

TC1 Source PLC cycle time,

TC2 Destination PLC cycle time,

CPL S Source PLC TSX MAP 107 module transmission processing time,

MPW Mapway network transit time,

CPL D Destination PLC TSX MAP 107 module transmission processing time.

The diagram below shows the application-to-application transfer time depending on the cycle time of the source PLC and the network load factor:

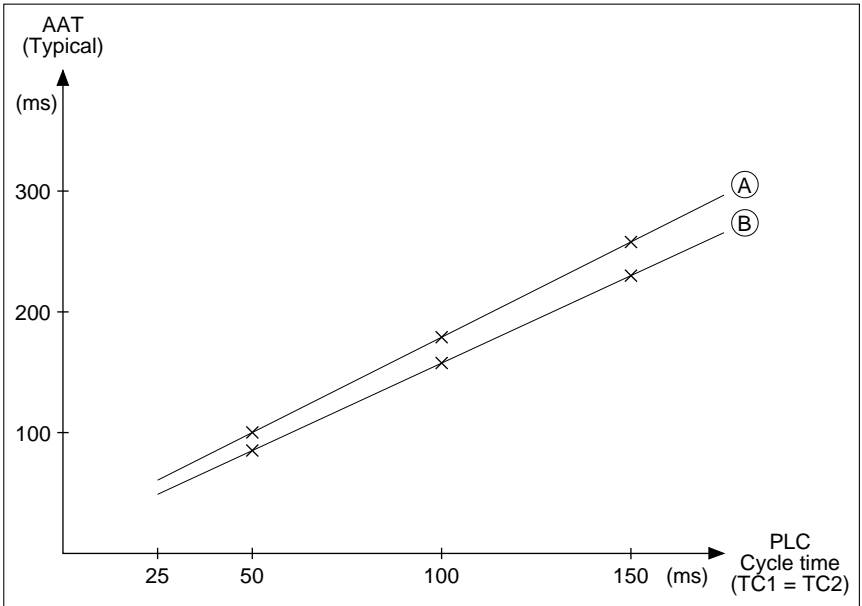

- Ⓐ Heavily loaded network (network cycle time = 30 ms),
- Ⓑ Lightly loaded network (network cycle time = 2 ms),

The application-to-application transfer time varies only slightly due to the network load factor. It depends essentially on the cycle time of the two PLCs connected. If their cycle times are the same, the average application-to-application transfer time is 1.5 times the cycle time.

4.1-2 Telegram Transfer Time

TTT: The Telegram Transfer Time is the time that elapses between telegram transmission by the source station (OUTPUT TXT_i) and telegram reception by the interrupt task of the destination station (DONE bit accepted by the application program).

Example

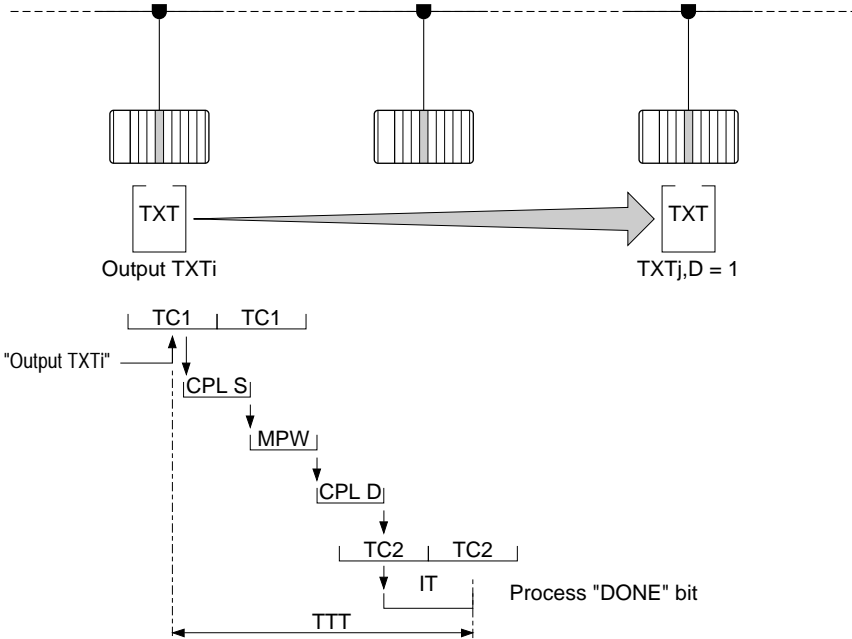

TC1 Source PLC cycle time,

TC2 Destination PLC cycle time,

CPL S Source PLC TSX MAP 1074 module transmission processing time,

MPW Mapway network transit time,

CPL D Destination TSX MAP 1074 module transmission processing time,

IT Interrupt task processing time.

The diagram below shows telegram transfer time depending on network cycle time:

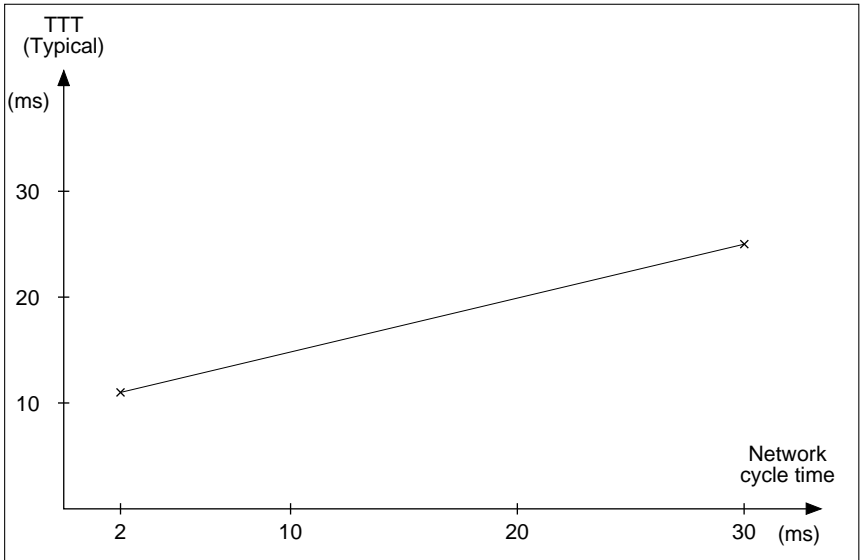

4.1-3 Request Transaction Time

RTT: The Uni-TE Request Transaction Time is the time that elapses between transmission of a request and processing, by the source, of the confirm that is sent back.

Example

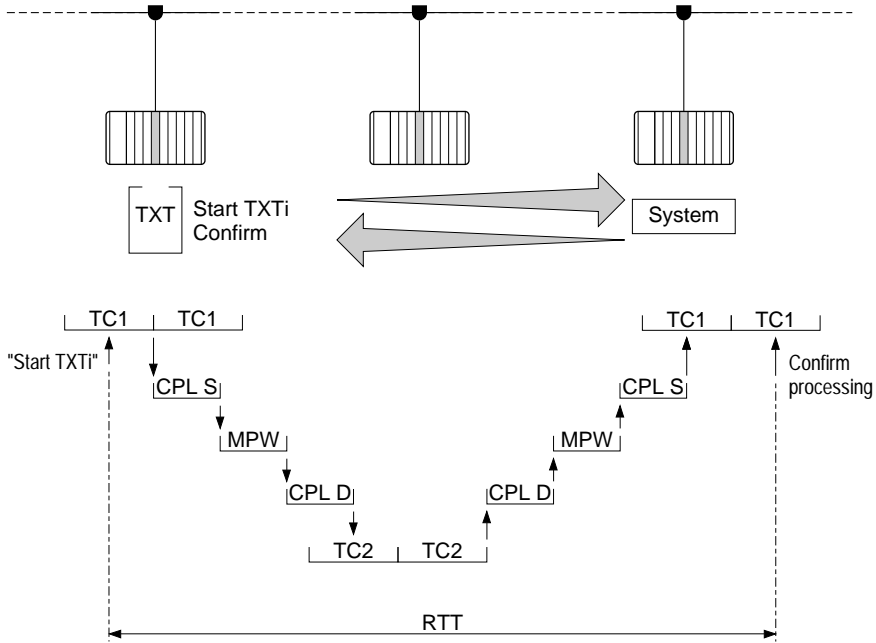

- TC1 Source PLC cycle time,
- TC2 Destination PLC cycle time,
- CPL S Source PLC TSX MAP 1074 module transmission processing time,
- MPW Mapway network transit time,
- CPL D Destination PLC TSX MAP 1074 module transmission processing time.

The diagram below shows the request transaction time depending on the cycle time of the source PLC and the network load factor:

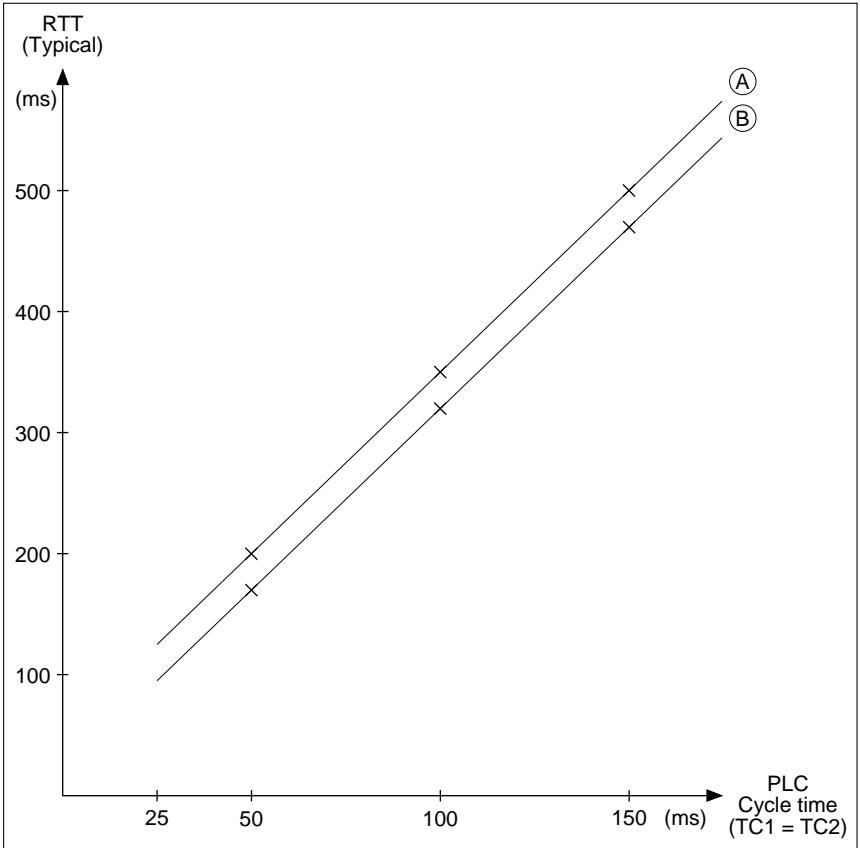

- Ⓐ Heavily loaded network (network cycle time = 30 ms),
- Ⓑ Lightly loaded network (network cycle time = 2 ms),

The request transaction time varies only slightly due to the network load factor. It depends essentially on the cycle time of the two PLCs connected. If their cycle times are the same, the average request transaction time is 3 times the cycle time.

4.1-4 Uploading Application Programs

PLT: Program Load Time is the time required to upload (or download) an application program via Mapway (upload and receive confirm). It depends on the size of the program to be transferred. The transfer time will therefore be almost entirely unaffected by the network load factor.

Example

Once logical connection is established, the cycle shown below applies to each program segment of 128 bytes.

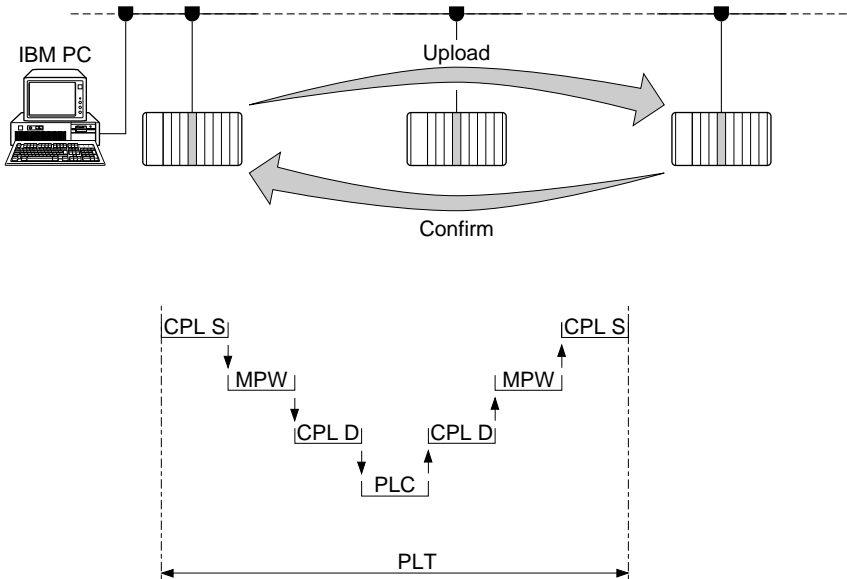

- CPL S Source PLC TSX MAP 1074 module transmission processing time,
- MPW Mapway network transit time,
- CPL D Destination PLC TSX MAP 1074 module transmission processing time,
- PLC The transfer time to the PLC of the destination station, with PLC stopped.

Note: If the FTX 507 is connected to the terminal port of a PLC, the following times must be added to the times shown above:

- Transfer time between workstation and PLC (typically one second per K byte),
- The PLC processing time (typically 2.5 times the cycle time).

The diagram below shows the time required to upload an application program over a heavily loaded Mapway network (network cycle time = 20 ms) depending on the size of the program:

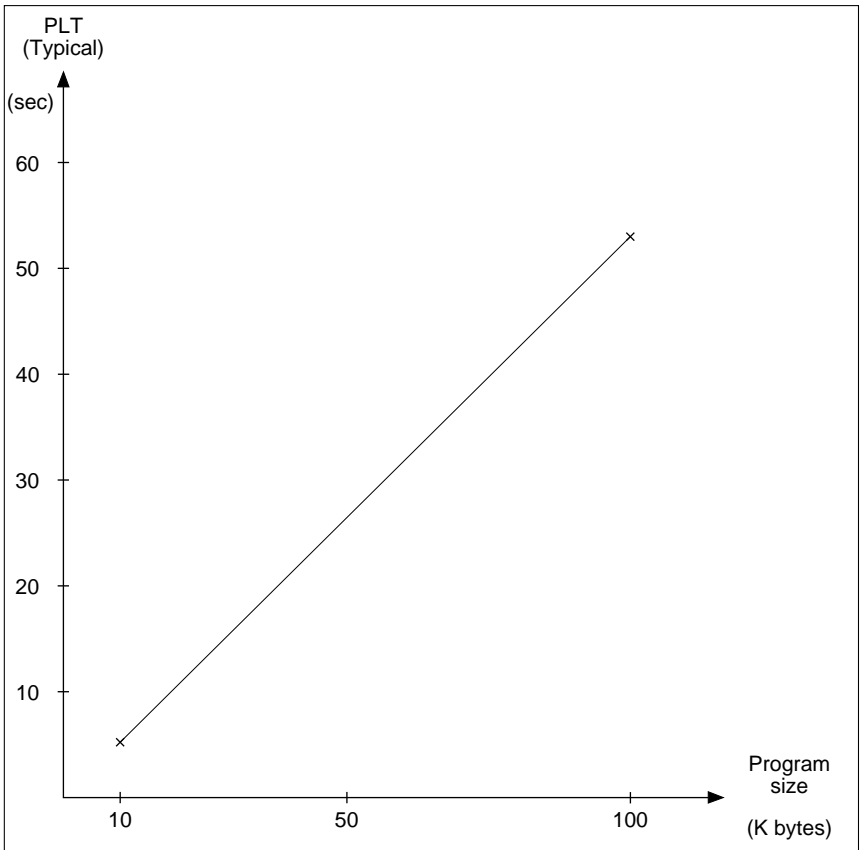

The application program upload (or download) transfer time is increased considerably when the terminal is not directly connected via an interface to the Mapway network.

This time only varies slightly depending on the network load.

4.1-5 Mapway-Mapway Bridge Transit Time

MMB: Is the time taken by a message to move from one network to another. It depends on the TSX MAP 1074 module processing time and on the time required by the bridge PLC processor to route the message.

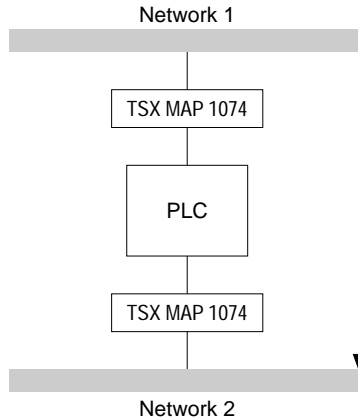

The Mapway-Mapway bridge transit time is approx. 20 ms for 128 characters.

4.1-6 Mapway-Telway Bridge Transit Time

MTB: Is the time taken by a message to move from a Mapway network to a Telway network or vice versa. It depends on the TSX MAP 1074 module processing time and on the time required by the bridge PLC processor to route the message.

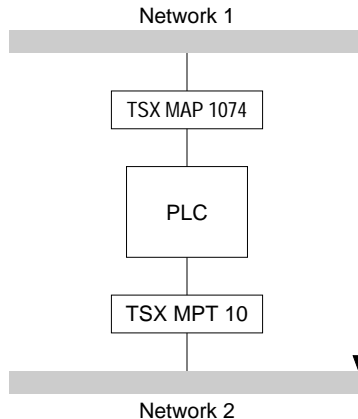

The Mapway-Telway bridge transit time is usually 1,5 times the PLC cycle time for each message.



Sub-section	Page
5.1 Module Design	74
5.1-1 Software Design	74
5.1-2 Hardware Design	77
5.2 TSX Series 7 V3 PLC Special Points	78
5.3 Uni-TE Read Requests	80
5.3-1 Read a Bit	80
5.3-2 Read a Word	81
5.3-3 Read Objects	82
5.3-4 Read a System Bit	84
5.3-5 Read the Memory Image of an I/O Bit	85
5.3-6 Read a Constant Word	87
5.3-7 Read a System Word	88
5.3-8 Read a COM Word	89
5.3-9 Read a Timer	90
5.3-10 Read a Monostable	91
5.3-11 Read a Counter	92
5.3-12 Read a Register	93
5.3-13 Read Grafcet Steps	94
5.3-14 Read a Double Word	95
5.3-15 Read a Constant Double Word	96
5.3-16 Read a Grafcet Step	97
5.4 Uni-TE Write Requests	98
5.4-1 Write a Bit	98
5.4-2 Write a Word	99
5.4-3 Write Objects	100
5.4-4 Write a System Bit	102
5.4-5 Write the Memory Image of an I/O Bit	103
5.4-6 Write a System Word	104
5.4-7 Write a COM Word	105
5.4-8 Write a Timer Preset	106
5.4-9 Write a Monostable Preset	107
5.4-10 Write a Counter Preset	108
5.4-11 Write a Register Input Word	109
5.4-12 Write a Double Word	110
5.4-13 Run	111
5.4-14 Stop	112

5.1 Module Design

5.1-1 Software Design

The diagram below shows the software design layout and the various functions of a Mapway network module.

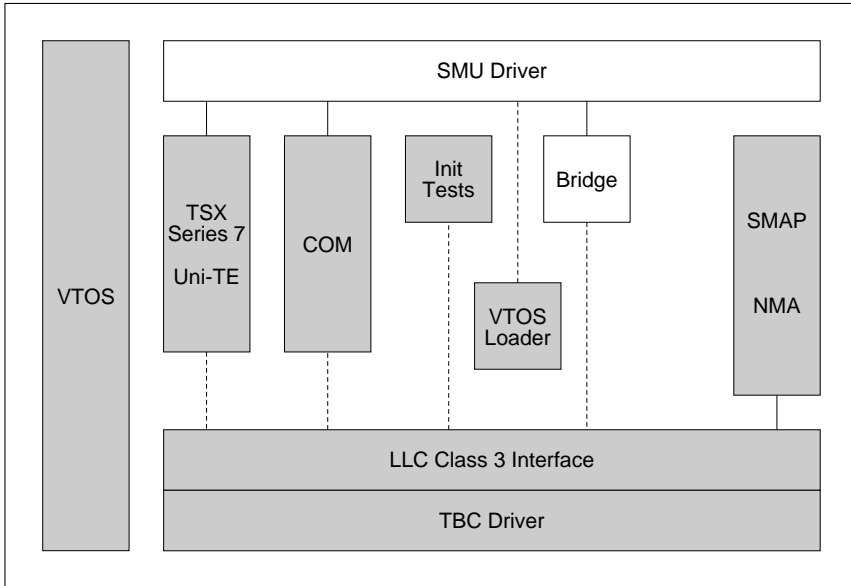

Definition of the Main Functions

Virtual Time Operating System (VTOS)

This is the real-time core that is used for:

- Executing the tasks in a multi-task environment,
- Communication between tasks using mailboxes and ports,
- Allocating and releasing the memory and the interrupts.

BUS Driver

This function ensures the control of communication between the PLC and the device. When a Telemecanique PLC is used, this function is designed as a driver for the PLC bus interface (SMU) and a SMU access interface that can be accessed by application services. This function controls three simultaneous communication channels: A synchronous COM channel, a synchronous and an asynchronous message channel (synchronization is ensured by the PLC cycle).

COM

This function controls the service that exchanges COM words over the network. It ensures the periodical transmission of a list of words initiated by the PLC processor. It provides a copy of the entire COM word field on each PLC cycle. An important part of this function is delegated to the SMU driver: control of a COM word communication memory channel between the network module and the PLC processor. The COM word function also interfaces with the LLC service (described below).

TSX Series 7

This is the specific Telemecanique network service. This function sends TSX Series 7 datagrams (text blocks, Uni-TE requests, program, adjust and debug requests, etc.) to the destination station on the network. It also receives datagrams from the network and transmits them to the PLC processor via the SMU driver. In addition, this function receives configuration or control requests that are redirected to the SMAP function that handles them (described below).

The TSX Series 7 service comprises a specific LOC-DIAG function that provides an overview of network control via the Uni-TE service and application protocol. Only some data objects are accessible by the LOC-DIAG service. This service converts some Uni-TE requests from the SMU into SMAP requests or responds instantly to other requests. In the other direction, SMAP responses are converted back using the Uni-TE protocol and sent back to the SMU.

System Management Access Protocol (SMAP)

This function controls all of the network functions that are distributed to the module. SMAP also communicates with a network control server called Network Management Agent (NMA). In order to respond to requests from the NMA, SMAP interfaces directly with each function in the module.

Logical Link Control (LLC)

This function implements the interface with the IEEE 802.2 Class 3 LLC and the IEEE 802.4 MAC sub-layer driver.

Init and Tests

This function performs two functions:

- Starting VTOS and any other Mapway program in order to end the self-tests,
- Synchronizing the changeover of the program from idle to running once the self-tests have been completed successfully. It is also used to share common resources such as structures and common addresses.

This service also controls the LED indicators and the seven segment LED displays on the front panel of the TSX MAP 1074 module.

VTOS Loader

This module function is used to load a process into the RAM of the network interface. This process can be performed in addition to, or in place of an existing interface process.

The VTOS Loader process normally interfaces directly with the SMU. In MAP network interfaces, an additional interface is built-in and this is accessed by the LLC for loading by the network.

Note: Mapway network interfaces are designed for future software extensions, and in particular MAP 3.0.

5.2-2 Hardware Design

The design of the TSX MAP 1074 module is shown in the diagram below:

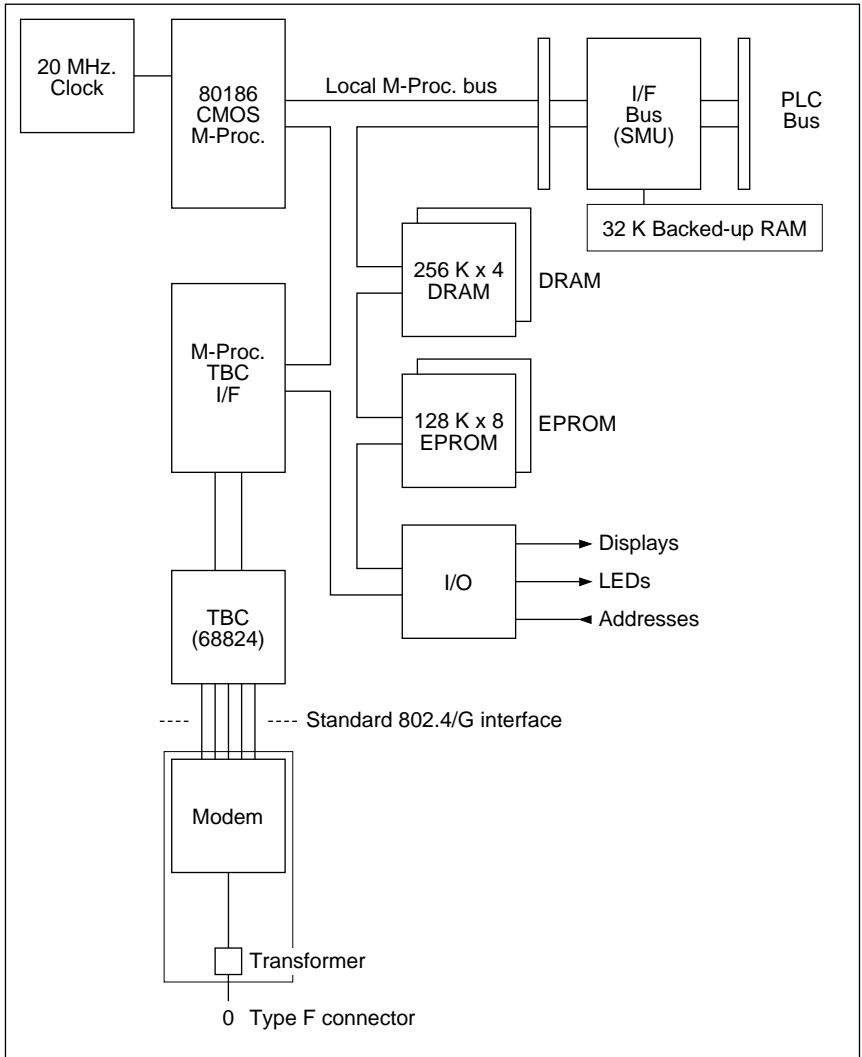

5 V Power consumption: 1.3 A Typical
1.6 A Maximum

5.2 TSX Series 7 V3 PLC Special Points

TSX Series 7 V3 PLCs (TSX 47-31, TSX 67-21 and TSX 87-31) have certain slight functional differences compared to TSX Series 7 Model 40 PLCs. A brief summary of these differences is given below.

Number of modules

- Only one Mapway or Telway module is allowed in each rack.
TSX Series 7 V3 PLC cannot therefore be used as bridge stations between networks but can be connected to a multiple network layout.

COM word service

- The COM word service (in transmission and reception) is restricted to stations with addresses from H'00' to H'0F'.
- COM size is restricted to four words per station. (A TSX Series 7 V3 station therefore imposes a four COM word size on all stations connected to the same network as itself).
- The update and transfer of all COM words is performed at the end of each master task cycle.
- When a module is configured, its activity (in read and write) in relation to COM words can be inhibited or enabled.
- Only system bits SY11 and SY12 are used (with the same functions as TSX Series 7 Model 40 PLCs).
- System words SW65 to SW99 do not apply. Two new system words are used however:

System word	Function	Description
SW0	Update COM words	Each bit in this word (0 to F) represents a station on the network (0 to 15). A bit at 1 shows that the corresponding station has sent its COM words. It is up to the user to reset this word to zero (by program).
SW2	Mapway station number	This word gives the decimal station number coded in the TSX MAP ACC1 Mapway module terminal block.

Uni-TE Service

- The Uni-TE service is identical to the one supported by TSX Series 7 Model 40 PLCs.
- The circular byte shift left instruction: SLCWORD(Source;Length) is not supported. When the "read objects" request (H'36') is used, shifting of data received can only be performed by program.

Application-to-application communication

- This service is identical to the one supported by TSX Series 7 Model 40 PLCs.

Priority communication - Telegram

- TSX Series 7 V3 PLC do not support this service.

5.3 Uni-TE Read Requests

5.3-1 Read a Bit

This request reads the value of a bit (0 or 1) and whether it is forced or not.

Request format

Request Code Hex.	Category Code	Bit Number
00/00	0 → 7	

Confirm format

Positive confirm

Confirm Code Hex.	Value	Forcing
30/48		

Value: An 8-bit string where the address of the first bit is the highest multiple of 8 contained in the bit number to be read (modulo 8).

Forcing: An 8-bit value used as a forcing indicator for the 8 “value” bits:

- 1 if the bit is forced, the forced value is in the value bit,
- 0 if the bit is not forced.

Negative confirm

Confirm Code Hex.
FD/253

Causes for rejection:

- Unknown request,
- Inadequate access rights,
- Address out of range.

5.3-2 Read a Word

This request reads a word (W).

Request format

Request Code Hex.	Category Code	Word Number
04/04	0 → 7	

Confirm format

Positive confirm

Confirm Code Hex.	Value
34/52	

Negative confirm

Confirm Code Hex.
FD/253

Causes for rejection:

- Unknown request,
- Inadequate access rights,
- Address out of range.

5.3-3 Read Objects

This request reads of simple objects (words or bit strings etc.).

Request format

Request Code Hex.	Category Code	Segment	Type of Object	Object Address	Number of Objects to Read
36/54	0 → 7				

Segment: Specifies the addressing mode used for the objects to be read and the position where they are located (in hexadecimal notation).

The segments accessible by TSX Series 7 PLCs are (in hexadecimal):

- 10: Common object space segment,
- 68: Internal word space segment,
- 69: Constant word space segment,
- 6C: Ctrl. user task space segment,
- 80: TSX Series 7 system object space segment.

Type of object: Specifies the type of object to read:

- 7: 16-bit signed integer,
- 8: 32-bit signed integer,
- 64: Task period.

Object address:

- The physical or logical address in the segment,
- The sequence number of the object in the segment:
- 0: Current date and time, in the common segment,
- 1: Stored time and date, in the common segment,
- 0: Programming port configuration in the system segment.

Confirm format

Positive confirm

Confirm Code Hex.	Type of Object	Data			
66/102					

Type of object: Returns the type of object selected when the request is sent.

Read objects (contd)

Negative confirm

Confirm Code Hex.
FD/253

Causes for rejection:

- Unknown request,
- Inadequate access rights,
- Unknown segment or object,
- Address out of range,
- Too many objects for the reception buffer.

Request Examples

Read words or double words

Segment: 68,
 Type of object: 7 → Wi, or 8 → DWi,
 Object address: index of the first Wi or DWi to read.

Read constant words or constant double words

Segment: 69,
 Type of object: 7 → CWi, or 8 → CDWi,
 Object address: index of the first CWi or CDWi to read.

Read Date and Time

Segment: 10 (common),
 Type of object: 0 by default,
 Object address: 0 → current time and date,
 1 → saved time and date,
 Quantity: 0 by default.

Read programming port configuration

Segment: 80 (TSX Series 7 system),
 Type of object: 0 by default,
 Object address: 0 → programming port configuration,
 Quantity: 0 by default.

Read task period

Segment: 6C (Ctrl),
 Type of object: 64 (task period),
 Object address: 2 → Fast task,
 3 → Master task,
 4 → Auxiliary task 0,
 5 → Auxiliary task 1,
 6 → Auxiliary task 2,
 7 → Auxiliary task 3,
 Quantity: 0 by default.

5.3-4 Read a System Bit

This request reads a system bit SY.

Request format

Request Code Hex.	Category Code	System Bit Number
01/01	0 → 7	

Confirm format

Positive confirm

Confirm Code Hex.	Value
31/49	

Value:

An 8-bit string, where the address of the first bit is the highest multiple of 8 contained in the system bit number to be read (modulo 8).

Only the bit corresponding to the bit to be found is significant.

Negative confirm

Confirm Code Hex.
FD/253

Causes for rejection:

- Unknown request,
- Inadequate access rights,
- Bit number out of range.

5.3-5 Read the Memory Image of an I/O Bit

This request reads the memory image generated by an I/O module.

Request format

Request Code Hex.	Category Code	I/O Module Location
02/02	0 → 7	

Module location: bit 0 → 2: Module number,
 bit 3 → 6: Rack number,
 bits 7 → 15: Reserved (0).

Confirm format

Positive confirm

Confirm Code Hex.	Fault Code	Configuration	Value	Forcing
32/50				

Fault Code: Bit 7 = Fault: (0 = no, 1 = yes),
 Bits 6 to 4 = 0,
 Bits 0 to 3 = Type of fault:
 0000: OK,
 0001: Terminal block or process fault,
 0010: Module absent,
 0011: Module failure,
 0100: Not an I/O module,
 0101: Incompatible with configuration,
 0110: Not configured,
 0111: Self-test error.

Configuration: bit 7: Configuration exists (0 = no, 1 = yes),
 bit 6: Defined type (0 = no, 1 = yes),
 bits 0 to 5: if type = 1 → catalog type number,
 if type = 0 → default type number.

Value: The value of the module I/O bits. If an 8-bit module is used, the MSB contains null values that are not significant. "Value" is only significant if the fault bit = 0 (bit 7) and the configuration bit = 1 (bit 7).

Read the Memory Image of an I/O Bit (contd)

Forcing:

Status of forcing:

- 0: The bit is not forced,
- 1: The bit is forced, its forcing state is displayed in the "value" parameter.

Negative confirm

Confirm Code Hex.
FD/253

Reasons for rejection:

- Unknown request,
- Inadequate access rights,
- Module number out of range.

5.3-6 Read a Constant Word

This request reads constant words (CW).

Request format

Request Code Hex.	Category code	Word Number
05/05	0 → 7	

Confirm format

Positive confirm

Confirm Code Hex.	Value
35/53	

Negative confirm

Confirm Code Hex.
FD/253

Causes for rejection:

- Unknown request,
- Inadequate access rights,
- Word number out of range.

5.3-7 Read a System Word

This request reads system words (CW).

Request format

Request Code Hex.	Category Code	Word Number
06/06	0 → 7	

Confirm format

Positive confirm

Confirm Code Hex.	Value
36/54	

Negative confirm

Confirm Code Hex.
FD/253

- Causes for rejection:
- Unknown request,
 - Inadequate access rights,
 - Word number out of range.

5.3-8 Read a COM Word

This request reads a COM (common) word.

Request format

Request Code Hex.	Category Code	Station Number	Word Number
07/07	0 → 7		

Confirm format

Positive confirm

Confirm Code Hex.	Station Size	Value
37/55		

Station size: The number of COM words generated.

Negative confirm

Confirm Code Hex.
FD/253

Causes for rejection:

- Unknown request,
- Inadequate access rights,
- Word number out of range,
- RAM cannot be executed,
- Station number out of range.

5.3-9 Read a Timer

This request reads all of the parameters of a timer.

Request format

Request Code Hex.	Category Code	Time Number
09/09	0 → 7	

Confirm format

Positive confirm

Confirm Code Hex.	Time Base	Timer Timed-out	Timer Running	Type of Preset	Preset Value	Current Value
39/57						

Time base: 0 → 10 ms
 1 → 100 ms
 2 → 1 sec.
 3 → 1 min.

Timer timed-out: 0 → no
 1 → yes

Timer running: 0 → no
 1 → yes

Type of preset: 0 → preset cannot be modified,
 1 → preset can be modified.

Negative confirm

Confirm Code Hex.
FD/253

Causes for rejection:

- Unknown request,
- Inadequate access rights,
- Timer number out of range,
- RAM cannot be executed.

5.3-10 Read a Monostable

This request reads all of the parameters of a monostable.

Request format

Request Code Hex.	Category Code	Monostable Number
0A/10	0 → 7	

Confirm format

Positive confirm

Confirm Code Hex.	Time Base	Monostable Running	Type of Preset	Preset Value	Current Value
3A/58					

Time base: 0 → 10 ms
 1 → 100 ms
 2 → 1 sec.
 3 → 1 min.

Monostable running: 0 → no
 1 → yes

Type of preset: 0 → preset cannot be modified
 1 → preset can be modified

Negative confirm

Confirm Code Hex.
FD/253

Causes for rejection: • Unknown request,
 • Inadequate access rights,
 • Monostable number out of range,
 • RAM cannot be executed.

5.3-11 Read a Counter

This request reads all of the parameters of a counter.

Request format

Request Code Hex.	Category Code	Counter Number
0B/11	0 → 7	

Confirm format

Positive confirm

Confirm Code Hex.	Down-count Overflow	Upcount Overflow	Counter Running	Type of Preset	Preset Value	Current Value
3B/59						

Downcount overflow: 1 if the current counter value has gone from 0 to 9999,

Upcount overflow: 1 if the current counter value has gone from 9999 to 0,

Counter running: 0 → no,
1 → yes,

Type of preset: 0 → preset cannot be modified,
1 → preset can be modified.

Negative confirm

Confirm Code Hex.
FD/253

Causes for rejection:

- Unknown request,
- Inadequate access rights,
- Counter number out of range,
- RAM cannot be executed.

5.3-12 Read a Register

This request reads all of the parameters of a register.

Request format

Request Code Hex.	Category Code	Register Number
0E/14	0 → 7	

Confirm format

Positive confirm

Confirm Code Hex.	Register Type	Register Empty	Register Full	Register Length	Input Word	Output Word
3E/62						

Register type: 0 = FIFO register,
1 = LIFO register,

Register empty: 0 → no,
1 → yes,

Register full: 0 → no,
1 → yes.

Negative confirm

Confirm Code Hex.
FD/253

Causes for rejection:

- Unknown request,
- Inadequate access rights,
- Register number out of range,
- RAM cannot be executed.

5.3-13 Read Grafcet Steps

This request reads the Grafcet step activity bits (Xi).

Request format

Request Code Hex.	Category Code	Portion Number
2A/42	0 → 7	

Portion number: 0 = portion [X0.....X127],
 1 = portion [X128.....X255],
 2 = portion [X256.....X383],
 3 = portion [X384.....X511].

Confirm format

Positive confirm

Confirm Code Hex.	Data
5A/90	

Register type: A succession of 128 bits corresponding to the step number in the selected portion:
 bit i = 0: step Xi inactive,
 bit i = 1: step Xi active.

Negative confirm

Confirm Code Hex.
FD/253

Causes for rejection:

- Unknown request,
- Inadequate access rights,
- Portion number out of range,
- No reservation.

5.3-14 Read a Double Word

This request reads a double word (DW).

Request format

Request Code Hex.	Category Code	Double Word Number
40/64	0 → 7	

Confirm format

Positive confirm

Confirm Code Hex.	Double Word Value
70/112	

Negative confirm

Confirm Code Hex.
FD/253

Causes for rejection:

- Unknown request,
- Inadequate access rights,
- Word number out of range,
- Odd word number.

5.3-15 Read a Constant Double Word

This request reads a constant double word (CDW).

Request format

Request Code Hex.	Category Code	Constant Double Word Value
41/65	0 → 7	

Confirm format

Positive confirm

Confirm Code Hex.	Constant Double Word Value
71/113	

Negative confirm

Confirm Code Hex.
FD/253

Causes for rejection:

- Unknown request,
- Inadequate access rights,
- Word number out of range,
- Odd word number.

5.3-16 Read a Grafcet Step

This request reads the state of a Grafcet step.

Request format

Request Code Hex.	Category Code	Type of Number	Reserved	Macro-Step Number	Step Number
4B/75	0 → 7		00		

Type of step: 0: Grafcet step,
1: Macro-step,
2: Macro-step entry step,
3: Macro-step exit step,
4: Macro-step step.

Macro step nbr.: Comprises the number of the required macro-step or 0 if the step type is 0.

Step nbr.: Comprises the number of the required step or 0 if the step type is 1, 2 or 3.

Confirm format

Positive confirm

Confirm Code Hex.	Active Step	Not Used		Not Used	Inhibited
7B/123		00	00	00	

Active step: 0 → no,
1 → yes,
Inhibited step: 0 → no,
1 → yes.

Negative confirm

Confirm Code Hex.
FD/253

Causes for rejection: • Unknown request,
• Inadequate access rights,
• Step number out of range.

5.4 Uni-TE Write Requests

5.4-1 Write a Bit

This request sets a bit to 1 or to 0.

Request format

Request Code Hex.	Category Code	System Bit Number	Bit Value
10/16	0 → 7		

Bit value: 0 → state 0,
 1 → state 1.

Confirm format

Positive confirm

Confirm Code Hex.
FE/254

Negative confirm

Confirm Code Hex.
FD/253

Causes for rejection:

- Unknown request,
- Inadequate access rights,
- Bit number out of range.

5.4-2 Write a Word

This request writes the content of a word.

Request format

Request Code Hex.	Category Code	Word Number	Word Value
14/20	0 → 7		

Confirm format

Positive confirm

Confirm Code Hex.
FE/254

Negative confirm

Confirm Code Hex.
FD/253

Causes for rejection:

- Unknown request,
- Inadequate access rights,
- Word number out of range.

5.4-3 Write Objects

This request writes simple objects (words, word strings, etc.).

Request format

Request Code Hex.	Category code	Segment	Type of Object	Object Address	Number of Objects to Write	Data
37/55	0 → 7					

Segment: Specifies the addressing mode and the addressing field (in hexadecimal):

- 10: Common object space segment,
- 68: Internal word space segment,
- 69: Constant word space segment,
- 6C: Ctrl user task space segment,
- 80: TSX Series 7 system object space segment.

Type of object: Specifies the object to write:

- 7: 16-bit signed integer,
- 8: 32-bit signed integer,
- 64: Task period.

Object address:

- The physical or logical address in the segment,
- The sequence number of the object in the segment:
- 0: Current date and time, in the common segment,
- 1: Programming port configuration in the system segment.

Confirm format

Positive confirm

Confirm Code Hex.
FE/254

Negative confirm

Confirm Code Hex.
FD/253

Write Objects (contd)**Negative confirm (contd)**

Causes for rejection:

- Unknown request,
- Inadequate access rights,
- Unknown object,
- Address of the last object out of range.

Request Examples**Write words or double words**

Segment: 68,
 Type of object: 7 → Wi or 8 → DWi,
 Object address: Index of the first Wi or DWi to write,
 Quantity: Number,
 Data: Table of n objects,

Write constant words or constant double words

Segment: 69,
 Type of object: 7 → CWi or 8 → CDWi,
 Object address: Index of the first CWi or CDWi to write,
 Quantity: Number,
 Data: Table of n objects,

Write Date and Time

Segment: 10 (common),
 Type of object: 0 by default,
 Object address: 0 → current time and date,
 Quantity: 0 by default,
 Data: 17 ASCII characters that contain the time and date information:
 YYYYMMDDHHMMSS.TZ
(T: tenths of a second, Z: trailer).

Write programming port configuration

Segment: 80 (TSX Series 7 system),
 Type of object: 0 by default,
 Object address: 0 → programming port configuration,
 Quantity: 0 by default,
 Data: 1 byte that describes the new configuration.

Write task period

Segment: 6C (Ctrl),
 Type of object: 64 (task period),
 Object address: 2 → Fast task,
 3 → Master task,
 4 → Auxiliary task 0,
 5 → Auxiliary task 1,
 6 → Auxiliary task 2,
 7 → Auxiliary task 3,
 Quantity: 0 by default,
 Data: New task period within the time base allowed for each task.

5.4-4 Write a System Bit

This request writes a system bit SY...

Request format

Request Code Hex.	Category Code	System Bit Number	Value
11/17	0 → 7		

Value: 0 or 1.

Confirm format

Positive confirm

Confirm Code Hex.
FE/254

Negative confirm

Confirm Code Hex.
FD/253

Causes for rejection:

- Unknown request,
- Inadequate access rights,
- Bit number out of range.

5.4-5 Write the Memory Image of an I/O Bit

This request writes the memory image of an I/O module. As memory image processing is used, no check is made to ensure that the module exists or is operating correctly.

Request format

Request Code Hex.	Category Code	I/O Module Location	I/O Bit Number	Value
12/18	0 → 7			

Module location: Bit 0 to 2: Module number,
Bit 3 to 6: Rack number,
Bits 7 to 15: Reserved (0).

I/O Bit number: 0 to 7: For an 8-bit module,
0 to F: For a 16-bit module.

Value: 0 or 1.

Confirm format

Positive confirm

Confirm Code Hex.
FE/254

Negative confirm

Confirm Code Hex.
FD/253

Causes for rejection:

- Unknown request,
- Inadequate access rights,
- I/O module number out of range,
- I/O bit number out of range.

5.4-6 Write a System Word

This request writes a system word (SW..).

Request format

Request Code Hex.	Category Code	System Word Number	Value
15/21	0 → 7		

Confirm format

Positive confirm

Confirm Code Hex.
FE/254

Negative confirm

Confirm Code Hex.
FD/253

Causes for rejection:

- Unknown request,
- Inadequate access rights,
- System word number out of range.

5.4-7 Write a COM Word

This request writes a COM (common) word.

Request format

Request Code Hex.	Category Code	Station Number	COM Word Number	Value
16/22	0 → 7			

Confirm format

Positive confirm

Confirm Code Hex.
FE/254

Negative confirm

Confirm Code Hex.
FD/253

Causes for rejection:

- Unknown request,
- Inadequate access rights,
- Word number out of range,
- RAM cannot be executed.

5.4-8 Write a Timer Preset

This request writes the preset value of a timer (T) if it can be modified.

Request format

Request Code Hex.	Category Code	Timer Number	Preset Value
17/23	0 → 7		

Preset value: Between 0 and 9999 (H'00' to H'270F' inclusive).

Confirm format

Positive confirm

Confirm Code Hex.
FE/254

Negative confirm

Confirm Code Hex.
FD/253

- Causes for rejection:
- Unknown request,
 - Inadequate access rights,
 - Timer number out of range,
 - Preset cannot be modified,
 - Preset value out of range,
 - Cannot execute RAM.

5.4-9 Write a Monostable Preset

This request writes the preset value of a monostable (M), if it can be changed.

Request format

Request Code Hex.	Category Code	Monostable Number	Preset Value
18/24	0 → 7		

Preset Value: Between 0 and 9999 (H'00' to H'270F') inclusive.

Confirm format

Positive confirm

Confirm Code Hex.
FE/254

Negative confirm

Confirm Code Hex.
FD/253

Causes for rejection:

- Unknown request,
- Inadequate access rights,
- Monostable number out of range,
- Preset cannot be changed,
- Preset value out of range,
- Cannot execute RAM.

5.4-10 Write a Counter Preset

This request writes the preset value of a counter (C).

Request format

Request Code Hex.	Category Code	Counter Number	Preset Value
19/25	0 → 7		

Preset Value: Between 0 and 9999 (H'00' to H'270F') inclusive.

Confirm format

Positive confirm

Confirm Code Hex.
FE/254

Negative confirm

Confirm Code Hex.
FD/253

Causes for rejection:

- Unknown request,
- Inadequate access rights,
- Counter number out of range,
- Preset cannot be modified,
- Preset value out of range,
- Cannot execute RAM.

5.4-11 Write a Register Input Word

This request writes a register input word (R).

Request format

Request Code Hex.	Category Code	Number Register	Input Word Value
1A/26	0 → 7		

Confirm format

Positive confirm

Confirm Code Hex.
FE/254

Negative confirm

Confirm Code Hex.
FD/253

Causes for rejection:

- Unknown request,
- Inadequate access rights,
- Register number out of range.

5.4-12 Write a Double Word

This request writes a double word (DW).

Request format

Request Code Hex.	Category Code	Double Word Value	Double Word Value
46/70	0 → 7		

Confirm format

Positive confirm

Confirm Code Hex.
FE/254

Negative confirm

Confirm Code Hex.
FD/253

Causes for rejection:

- Unknown request,
- Inadequate access rights,
- Word number out of range,
- Odd word number.

5.4-13 Run

This request sets a device to Run.

Request format

Request Code Hex.	Category Code
24/36	0 → 7

Attention:

Depending on the type of device, prior reservation may be required.

Confirm format

Positive confirm

Confirm Code Hex.
FE/254

Negative confirm

Confirm Code Hex.
FD/253

Causes for rejection:

- Unknown request,
- Inadequate access rights,
- No reservation.

5.4-14 Stop

This request stops a device.

Request format

Request Code Hex.	Category Code
25/37	0 → 7

Attention: Depending on the type of device, prior reservation may be required.

Confirm format

Positive confirm

Confirm Code Hex.
FE/254

Negative confirm

Confirm Code Hex.
FD/253

Causes for rejection:

- Unknown request,
- Inadequate access rights,
- No reservation.