

# Twido Programmable Controllers

Discrete I/O Modules  
Hardware Guide

06/2011

---

The information provided in this documentation contains general descriptions and/or technical characteristics of the performance of the products contained herein. This documentation is not intended as a substitute for and is not to be used for determining suitability or reliability of these products for specific user applications. It is the duty of any such user or integrator to perform the appropriate and complete risk analysis, evaluation and testing of the products with respect to the relevant specific application or use thereof. Neither Schneider Electric nor any of its affiliates or subsidiaries shall be responsible or liable for misuse of the information contained herein. If you have any suggestions for improvements or amendments or have found errors in this publication, please notify us.

No part of this document may be reproduced in any form or by any means, electronic or mechanical, including photocopying, without express written permission of Schneider Electric.

All pertinent state, regional, and local safety regulations must be observed when installing and using this product. For reasons of safety and to help ensure compliance with documented system data, only the manufacturer should perform repairs to components.

When devices are used for applications with technical safety requirements, the relevant instructions must be followed.

Failure to use Schneider Electric software or approved software with our hardware products may result in injury, harm, or improper operating results.

Failure to observe this information can result in injury or equipment damage.

© 2011 Schneider Electric. All rights reserved.

---

# Table of Contents



---

	<b>Safety Information</b> .....	<b>5</b>
	<b>About the Book</b> .....	<b>9</b>
<b>Chapter 1</b>	<b>Overview for TWD Discrete I/O Modules</b> .....	<b>11</b>
	About TWD Discrete I/O Modules .....	12
	Main Features of the TWD Discrete I/O Modules .....	14
<b>Chapter 2</b>	<b>Installation</b> .....	<b>15</b>
2.1	Installation Overall Instructions .....	16
	Installation Guidelines .....	17
	Installation Preparation .....	20
	Compact and Modular Bases Mounting Positions .....	21
	Assembling an Expansion I/O module to a Base .....	23
	Disassembling an Expansion I/O Module from a Base .....	25
	Minimum Clearances for Bases and Expansion I/O Modules in a Control Panel .....	26
2.2	Installation of TWD Discrete I/O Modules .....	28
	Dimensions for TWD Discrete I/O Modules .....	29
	How to Directly Mount a TWD Discrete I/O Module on a Panel Surface ..	32
	How to Install and Remove a TWD Discrete I/O Module from a DIN Rail ..	34
<b>Chapter 3</b>	<b>Description of TWD Discrete I/O Modules</b> .....	<b>37</b>
3.1	TWD Discrete I/O Modules Description .....	38
	Overview of TWD Discrete I/O Modules .....	39
	Parts Description of TWD Discrete I/O Modules .....	42
3.2	Wiring Rules and Recommendations for TWD Discrete I/O Modules .....	44
	Wiring Rules and Recommendations for Discrete I/O Modules .....	44
3.3	Specifications and Wiring Diagrams for TWD Discrete Input Modules .....	49
	General Specifications for the TWD Discrete Input Modules .....	50
	Electrical Specifications for the TWD Discrete Input Modules .....	51
	Input Specifications for the TWD Discrete Input Modules .....	52
	TWD Discrete Input Modules Wiring Diagrams .....	55

---

3.4	Specifications and Wiring Diagrams for TWD Relay Output Modules . . .	62
	General Specifications for the TWD Relay Output Modules . . . . .	63
	Electrical Specifications for the TWD Relay Output Modules . . . . .	64
	Output Specifications for the TWD Relay Output Modules . . . . .	65
	TWD Relay Output Modules Wiring Diagrams. . . . .	66
3.5	Specifications and Wiring Diagrams for TWD Transistor Output Modules	69
	General Specifications for the TWD Transistor Output Modules . . . . .	70
	Electrical Specifications for the TWD Transistor Output Modules . . . . .	71
	Output Specifications for the TWD Transistor Output Modules . . . . .	72
	TWD Transistor Output Module Wiring Diagrams . . . . .	74
3.6	Specifications and Wiring Diagrams for TWD Discrete Mixed I/O Modules	79
	General Specifications for the TWD Mixed I/O Modules . . . . .	80
	Electrical Specifications for the TWD Mixed I/O Modules . . . . .	81
	I/O Specifications for the TWD Mixed I/O Modules . . . . .	82
	TWD Mixed I/O Module Wiring Diagrams . . . . .	85
<b>Appendices</b>	.....	<b>89</b>
<b>Appendix A</b>	<b>The DIN Rail</b> .....	<b>91</b>
	The DIN Rail . . . . .	91
<b>Appendix B</b>	<b>IEC Symbols</b> .....	<b>93</b>
	Glossary of Symbols . . . . .	93
<b>Appendix C</b>	<b>Agency Compliance</b> .....	<b>95</b>
	Agency Requirements . . . . .	95
<b>Glossary</b>	.....	<b>97</b>
<b>Index</b>	.....	<b>105</b>

---

## Safety Information

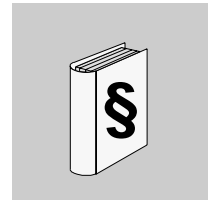

---

### Important Information

#### NOTICE

Read these instructions carefully, and look at the equipment to become familiar with the device before trying to install, operate, or maintain it. The following special messages may appear throughout this documentation or on the equipment to warn of potential hazards or to call attention to information that clarifies or simplifies a procedure.



The addition of this symbol to a Danger or Warning safety label indicates that an electrical hazard exists, which will result in personal injury if the instructions are not followed.



This is the safety alert symbol. It is used to alert you to potential personal injury hazards. Obey all safety messages that follow this symbol to avoid possible injury or death.

### **DANGER**

**DANGER** indicates an imminently hazardous situation which, if not avoided, **will result in** death or serious injury.

### **WARNING**

**WARNING** indicates a potentially hazardous situation which, if not avoided, **can result in** death or serious injury.

---

**⚠ CAUTION**

**CAUTION** indicates a potentially hazardous situation which, if not avoided, **can result in** minor or moderate injury.

**CAUTION**

**CAUTION**, used without the safety alert symbol, indicates a potentially hazardous situation which, if not avoided, **can result in** equipment damage.

**PLEASE NOTE**

Electrical equipment should be installed, operated, serviced, and maintained only by qualified personnel. No responsibility is assumed by Schneider Electric for any consequences arising out of the use of this material.

A qualified person is one who has skills and knowledge related to the construction and operation of electrical equipment and its installation, and has received safety training to recognize and avoid the hazards involved.

**General Warnings and Cautions**

**⚠ DANGER**

**HAZARD OF ELECTRIC SHOCK, BURN OR EXPLOSION**

Turn off all power before starting installation, removal, wiring, maintenance or inspection of the smart relay system.

**Failure to follow these instructions will result in death or serious injury.**

**⚠ WARNING**

**EXPLOSION HAZARD**

- Substitution of components may impair suitability for Class I, Div 2 compliance.
- Do not disconnect equipment unless power has been switched off or the area is known to be non-hazardous.

**Failure to follow these instructions can result in death, serious injury, or equipment damage.**

---

## **WARNING**

### **UNINTENDED EQUIPMENT OPERATION**

- Turn power off before installing, removing, wiring, or maintaining.
- This product is not intended for use in safety critical machine functions. Where personnel and or equipment hazards exist, use appropriate safety interlocks.
- Do not disassemble, repair, or modify the modules.
- This controller is designed for use within an enclosure.
- Install the modules in the operating environment conditions described.
- Use the sensor power supply only for supplying power to sensors connected to the module.
- For power line and output circuits, use a fuse designed to Type T standards per IEC60127. The fuse must meet the circuit voltage and current requirements.  
Recommended: Littelfuse® 218 Series, 5x20mm time lag (slow blow) fuses.

**Failure to follow these instructions can result in death, serious injury, or equipment damage.**





---

## About the Book

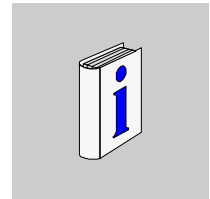

---

### At a Glance

#### Document Scope

This manual provides parts descriptions, specifications, wiring diagrams, installation, setup, and troubleshooting information for Twido Discrete I/O and AS-Interface modules.

#### Validity Note

The information in this manual is applicable **only** for Twido products. This documentation is valid for TwidoSuite Version 2.3.

#### User Comments

We welcome your comments about this document. You can reach us by e-mail at [techcomm@schneider-electric.com](mailto:techcomm@schneider-electric.com).

---

---

# Overview for TWD Discrete I/O Modules

# 1

---

## Introduction

This chapter provides an overview of the TWD Discrete I/O modules, their maximum configurations, and their main functions.

## What's in this Chapter?

This chapter contains the following topics:

Topic	Page
About TWD Discrete I/O Modules	12
Main Features of the TWD Discrete I/O Modules	14

## About TWD Discrete I/O Modules

### Introduction

There are 15 Discrete expansion I/O modules which can be added to Twido bases as additional I/O to these bases.

These discrete I/O modules are of three types:

- Input modules
- Output modules
- Mixed modules

### Discrete Expansion I/O Modules

The following table lists the discrete and relay expansion I/O modules:

Module Name	Reference	Channels	Channel type	Input/Output type	Terminal type
<b>Input modules</b>					
8-point input	TWDDDI8DT	8	Inputs	24 VDC	Removable terminal block
8-point input	TWDDAI8DT	8	Inputs	120 VAC	Removable terminal block
16-point input	TWDDDI16DT	16	Inputs	24 VDC	Removable terminal block
16-point input	TWDDDI16DK	16	Inputs	24 VDC	Connector
32-point input	TWDDDI32DK	32	Inputs	24 VDC	Connector
<b>Output Modules</b>					
8-point output	TWDDD08UT	8	Outputs	Transistor sink	Removable terminal block
8-point output	TWDDD08TT	8	Outputs	Transistor source	Removable terminal block
8-point output	TWDDRA8RT	8	Outputs	Relay	Removable terminal block
16-point output	TWDDRA16RT	16	Outputs	Relay	Removable terminal block
16-point output	TWDDDO16UK	16	Outputs	Transistor sink	Connector
16-point output	TWDDDO16TK	16	Outputs	Transistor source	Connector
32-point output	TWDDDO32UK	32	Outputs	Transistor sink	Connector
32-point output	TWDDDO32TK	32	Outputs	Transistor source	Connector

Module Name	Reference	Channels	Channel type	Input/Output type	Terminal type
<b>Mixed modules</b>					
4-point input/4-point output	TWDDMM8DRT	4	Inputs	24 VDC	Removable terminal block
		4	Outputs	Relay	
16-point input/8-point output	TWDDMM24DRF	16	Inputs	24 VDC	Non-removable terminal block
		8	Outputs	Relay	

## Cables

The following table lists the cables:

Cable name	Reference
<b>Discrete I/O Cables</b>	
3 meter, connector for controller to free wire	TWDFCW30M
5 meter, connector for controller to free wire	TWDFCW50M
3 meter, connector for expansion I/O module to free wire	TWDFCW30K
5 meter, connector for expansion I/O module to free wire	TWDFCW50K
<b>Telefast® Cables for Twido discrete I/O expansion modules</b>	
Cable equipped with a 20-way HE 10 connector at each end. (AWG 28 / 0.08 mm <sup>2</sup> ; length: 0.5 m / 1.64 ft)	ABF T20E050
Cable equipped with a 20-way HE 10 connector at each end. (AWG 28 / 0.08 mm <sup>2</sup> ; length: 1 m / 3.28 ft)	ABF T20E100
Cable equipped with a 20-way HE 10 connector at each end. (AWG 28 / 0.08 mm <sup>2</sup> ; length: 2 m / 6.56 ft)	ABF T20E200

## Main Features of the TWD Discrete I/O Modules

### Introduction

By default all I/Os on the bases are configured as discrete I/Os.

The range of Twido I/O modules includes input modules, output modules and mixed input/output modules

### Main Features

The following table lists the main features of the discrete I/O modules by type of module:

Type of discrete I/O module	Description
Input modules	There are two types of discrete input modules <ul style="list-style-type: none"> <li>● one 120 VAC discrete input module                             <ul style="list-style-type: none"> <li>● 8 channels</li> <li>● fitted with a removable screw terminal block</li> </ul> </li> <li>● four 24 VDC discrete input modules                             <ul style="list-style-type: none"> <li>● one 8-channel module</li> <li>● two 16-channel modules</li> <li>● one 32-channel module</li> <li>● equipped with either removable screw terminal blocks or HE 10 type connector</li> <li>● either sink modules or source modules</li> </ul> </li> </ul>
Output modules	There are 8 discrete output modules comprising: <ul style="list-style-type: none"> <li>● two output modules with 8 and 16 relay outputs</li> <li>● three output modules with 8, 16 or 32-channel sink transistor outputs</li> <li>● three output modules with 8, 16 or 32-channel source transistor outputs</li> <li>● equipped with either removable screw terminal blocks or HE 10 type connector</li> </ul>
Mixed I/O modules	There are 2 discrete mixed input and output modules comprising: <ul style="list-style-type: none"> <li>● one 4-channel input / 4-channel relay output module                             <ul style="list-style-type: none"> <li>● with removable screw terminal block</li> </ul> </li> <li>● one 16-channel input / 8-channel relay output module                             <ul style="list-style-type: none"> <li>● with non-removable spring terminal block</li> </ul> </li> </ul>

---

# Installation

# 2

---

## Introduction

This chapter provides installation overall instructions for installation preparation, installation and mounting instructions for the Twido discrete I/O modules, and how to connect the power supply.

## What's in this Chapter?

This chapter contains the following sections:

Section	Topic	Page
2.1	Installation Overall Instructions	16
2.2	Installation of TWD Discrete I/O Modules	28

## 2.1 Installation Overall Instructions

---

### Introduction

This section provides information for installation preparation, how to assemble and disassemble discrete I/O modules, and minimum clearances for discrete I/O modules.

### What's in this Section?

This section contains the following topics:

<b>Topic</b>	<b>Page</b>
Installation Guidelines	17
Installation Preparation	20
Compact and Modular Bases Mounting Positions	21
Assembling an Expansion I/O module to a Base	23
Disassembling an Expansion I/O Module from a Base	25
Minimum Clearances for Bases and Expansion I/O Modules in a Control Panel	26



## Installation Guidelines

### NOTICE

Electrical equipment should be serviced only by qualified personnel. No responsibility is assumed by Schneider Electric for any consequences arising out of the use of this material. This document is not intended as an instruction manual for untrained persons.

(c) 2008 Schneider Electric All Rights Reserved

### Additional Information

Those responsible for the application, implementation or use of this product must ensure that the necessary design considerations have been incorporated into each application, completely adhering to applicable laws, performance and safety requirements, regulations, codes and standards.

### General Information

## DANGER

### HAZARD OF ELECTRIC SHOCK, EXPLOSION OR ARC FLASH

- Disconnect all power from all equipment including connected devices prior to removing any covers or doors, or installing or removing any accessories, hardware, cables, or wires except under the specific conditions specified in the appropriate hardware guide for this equipment.
- Always use a properly rated voltage sensing device to confirm the power is off where and when indicated.
- Replace and secure all covers, accessories, hardware, cables, and wires and confirm that a proper ground connection exists before applying power to the unit.
- Use only the specified voltage when operating this equipment and any associated products.

**Failure to follow these instructions will result in death or serious injury.**

## **WARNING**

### **EXPLOSION HAZARD**

- This equipment is suitable for use in Class 1, Division 2, Groups A, B, C and D or non-hazardous locations only.
- Substitution of components may impair suitability for Class I, Division 2 compliance.
- Do not disconnect equipment unless power has been switched off or the area is known to be non-hazardous.

**Failure to follow these instructions can result in death, serious injury, or equipment damage.**

## **WARNING**

### **UNINTENDED EQUIPMENT OPERATION**

- This product is not intended for use in safety critical machine functions. Where personnel and or equipment hazards exist, use appropriate safety interlocks.
- Do not disassemble, repair, or modify the modules.
- This controller is designed for use within an enclosure appropriately rated for its intended environment.
- Install the modules in the operating environment conditions described.
- Use the sensor power supply only for supplying power to sensors connected to the module.
- For power line and output circuits, use a fuse in compliance with local and national requirements for the circuit voltage and current requirements.  
Recommended: Littelfuse® 218 Series, 5x20 mm time lag (slow blow) fuses.

**Failure to follow these instructions can result in death, serious injury, or equipment damage.**

## WARNING

### LOSS OF CONTROL

- The designer of any control scheme must consider the potential failure modes of control paths and, for certain critical control functions, provide a means to achieve a safe state during and after a path failure. Examples of critical control functions are emergency stop and overtravel stop.
- Separate or redundant control paths must be provided for critical control functions.
- System control paths may include communication links. Consideration must be given to the implications of unanticipated transmission delays or failures of the link<sup>1</sup>.
- Each implementation of the Twido Programmable Controller must be individually and thoroughly tested for proper operation before being placed into service.

**Failure to follow these instructions can result in death, serious injury, or equipment damage.**

<sup>1</sup>For additional information refer to NEMA ICS 1.1 (latest edition), "Safety Guidelines for the Application, Installation, and Maintenance of Solid State Control."

### Before Starting

Before installing any of the products read the safety information at the beginning of this book.

## CAUTION

### EQUIPMENT DAMAGE

Before adding/removing any module or adapter, turn off the power to the controller. Otherwise, the module, adapter, or controller may be damaged, or the controller may not operate correctly.

**Failure to follow these instructions can result in injury or equipment damage.**

**NOTE:** All options and expansion I/O modules are to be assembled before installing the control system on a DIN rail, onto a mounting plate, or in a control panel. Remove the Twido System from a DIN rail, a mounting plate, or a control panel before disassembling the expansion I/O modules.

## Installation Preparation

### Introduction

The following section provides information on preparation for discrete I/O modules.

### Before Starting

Before installing any of the TwidoSuite products read the safety information at the beginning of this book.

 <b>CAUTION</b>
--

<b>EQUIPMENT DAMAGE</b>
-------------------------

Before adding/removing any module or adapter, turn off the power to the base. Otherwise, the module, adapter, or base may be damaged, or the base may not operate correctly.
--

<b>Failure to follow these instructions can result in injury or equipment damage.</b>
---

**NOTE:** All options and discrete I/O modules are to be assembled before installing a Twido system on a DIN rail, onto a mounting plate, or in a control panel. It should be removed from a DIN rail, a mounting plate, or a control panel before disassembling the modules.

## Compact and Modular Bases Mounting Positions

### Introduction

This section shows the correct and incorrect mounting positions for all bases.

**NOTE:** Keep adequate spacing for proper ventilation and to maintain an ambient temperature between 0°C (32°F) and 55°C (131°F).

### **⚠ CAUTION**

#### **OVERHEATING HAZARD**

Do not place heat generating devices such as transformers and power supplies underneath the controllers or expansion I/O modules.

**Failure to follow these instructions can result in injury or equipment damage.**

### Correct Mounting Position for all Bases

Compact and Modular bases must be mounted horizontally on a vertical plane as shown in the figures below.

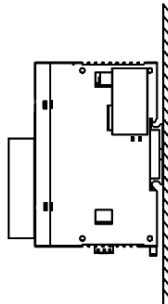

Compact base with an expansion I/O module

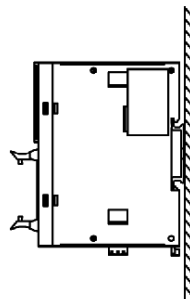

Modular base with an expansion I/O module

### Correct and Incorrect Mounting Positions for Compact Bases

A Compact base should only be positioned as shown in "Correct Mounting Position for all Bases" figure. When the ambient temperature is 35°C (95°F) or below, the Compact base can also be mounted upright on a horizontal plane as shown in (1). When the ambient temperature is 40°C (104°F) or below, the Compact base can also be mounted sideways on a vertical place as shown in figure (2). Figure (3) shows an incorrect mounting position.

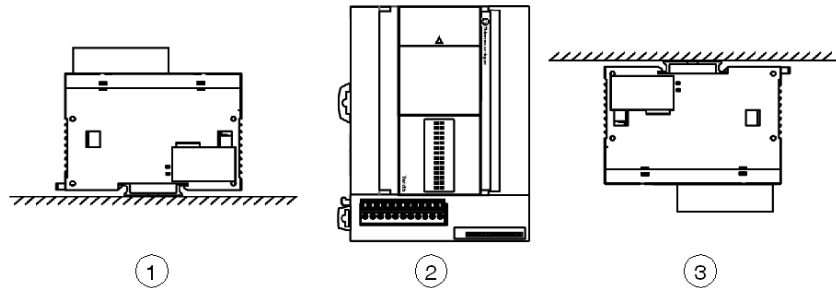

### Incorrect Mounting Positions for Modular Bases

A Modular base should only be positioned as shown in "Correct Mounting Position for all Bases" figure. The figures below show the incorrect mounting positions for all Modular bases.

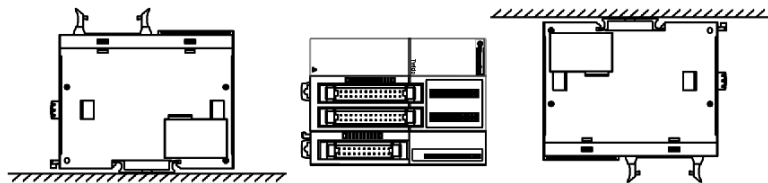

## Assembling an Expansion I/O module to a Base

### Introduction

This section shows how to assemble an expansion I/O module to a base. This procedure is for both Compact and Modular bases. Your base and expansion I/O module may differ from the illustrations in this procedure.

### **⚠ WARNING**

#### **UNEXPECTED EQUIPMENT OPERATION**

Update the software each time you change the hardware configuration of the I/O expansion bus. Otherwise, the expansion bus will no longer operate while the local base inputs and outputs will continue to operate.

**Failure to follow these instructions can result in death, serious injury, or equipment damage.**

### Assembling an Expansion I/O Module to a Base.

The following procedure shows how to assemble a base and an expansion I/O module together.

Step	Action
1	Remove the expansion connector cover from the base.
2	Verify that the black latch button on the I/O module is in the up position.

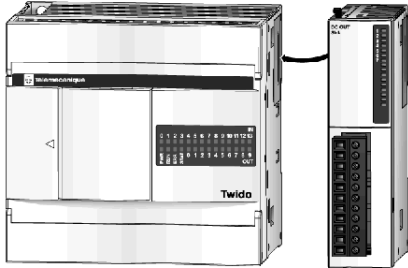

Step	Action
3	<p>Align the connector on the left side of the Expansion I/O module with the connector on the right side of the base.</p> 
4	<p>Press the expansion I/O module to the base until it "clicks" into place.</p>
5	<p>Push down the black latch button on the top of the expansion I/O module to lock the module to the base.</p>



## Disassembling an Expansion I/O Module from a Base

### Introduction

This section describes how to disassemble an expansion I/O module from a base. This procedure is for both Compact and Modular bases. Your base and expansion I/O module may differ from the illustrations in these procedures but the basic mechanism procedures are still applicable.

### Disassembling an Expansion I/O Module from a Base.

The following procedure describes how to disassemble an expansion I/O module from a base.

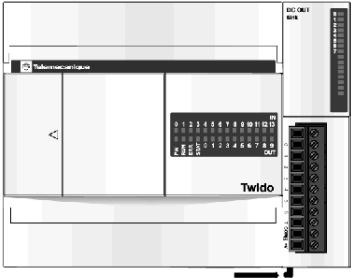
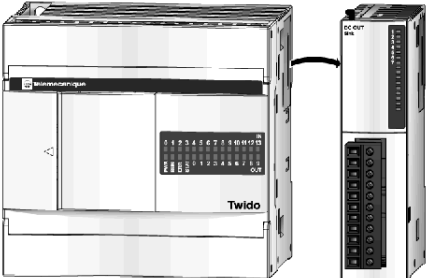
Step	Action
1	Remove the assembled base and module from the DIN rail before disassembling them, see <i>The DIN Rail</i> , page 91.
2	Push up the black latch from the bottom of the expansion I/O module to disengage it from the base. 
3	Pull apart the base and module. 

## Minimum Clearances for Bases and Expansion I/O Modules in a Control Panel

### Introduction

This section provides the minimum clearances for bases and expansion I/O modules in a control panel.

### Minimum Clearances for a Compact Base and Expansion I/O Modules

In order to maintain a natural circulation of air around the Compact base and expansion I/O modules in a control panel, observe the minimum clearances shown in the figures below.

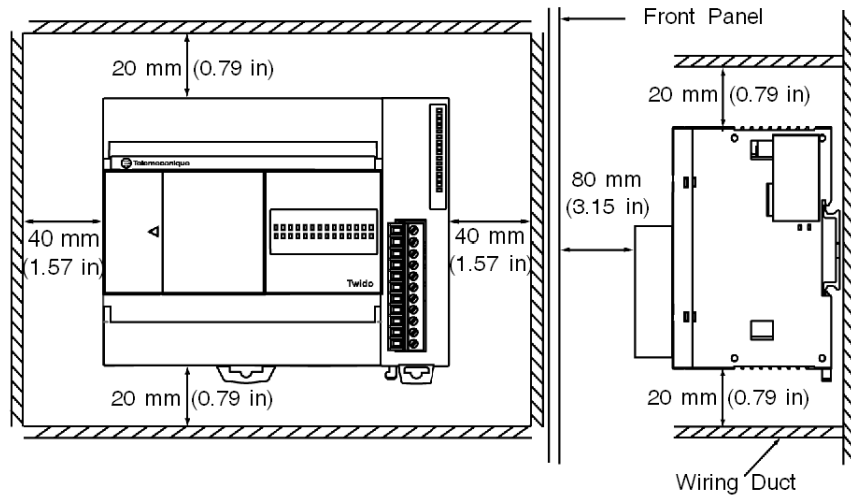

### Minimum Clearances for a Modular Base and Expansion I/O Modules

In order to maintain a natural circulation of air around the Modular base and expansion I/O modules in a control panel, observe the minimum clearances shown in the figures below.

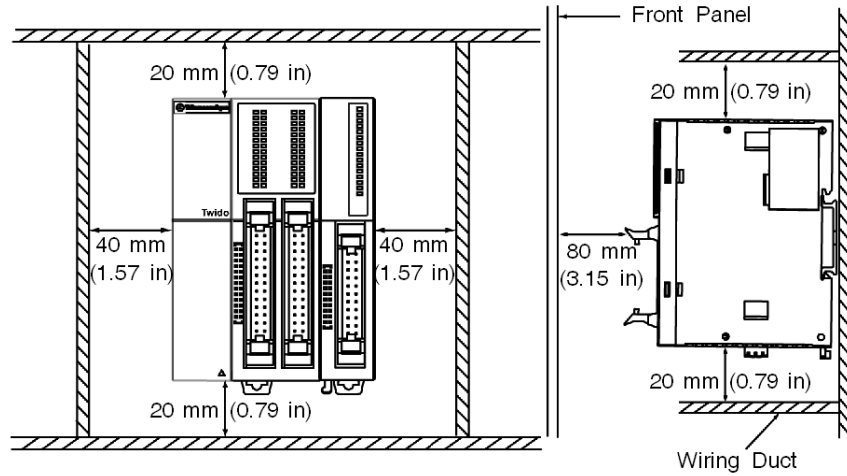

## 2.2 Installation of TWD Discrete I/O Modules

---

### Introduction

This section provides Information about installing the TWD Discrete I/O modules.

### What's in this Section?

This section contains the following topics:

<b>Topic</b>	<b>Page</b>
Dimensions for TWD Discrete I/O Modules	29
How to Directly Mount a TWD Discrete I/O Module on a Panel Surface	32
How to Install and Remove a TWD Discrete I/O Module from a DIN Rail	34

## Dimensions for TWD Discrete I/O Modules

### Introduction

The following section shows the dimensions for all TWD discrete I/O modules.

### Discrete I/O Modules (8 In and/or Out)

The following diagrams show the dimensions for the 8 input and/or output discrete modules: TWDDDI8DT, TWDDAI8DT, TWDDRA8RT, TWDDDO8TT, TWDDDO8UT, TWDDMM8DRT.

Illustrations showing a TWDDDI8DT or a TWDDAI8DT module:

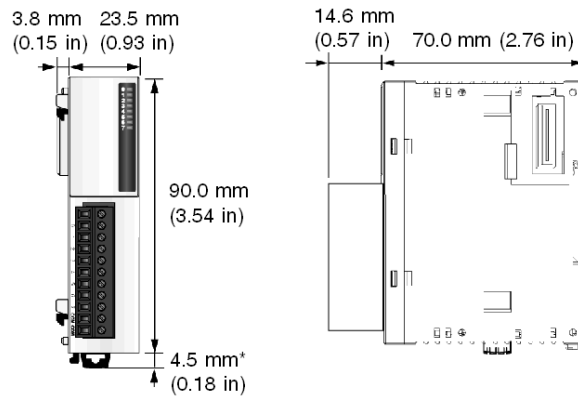

**NOTE:** \* 8.5 mm (0.33 in) when the clamp is pulled out.

**Discrete I/O Modules (16 In or Out with a Terminal Block)**

The following diagrams show the dimensions for the TWDDDI16DT and TWDDRA16RT discrete I/O modules.

Illustrations showing a TWDDDI16DT module:

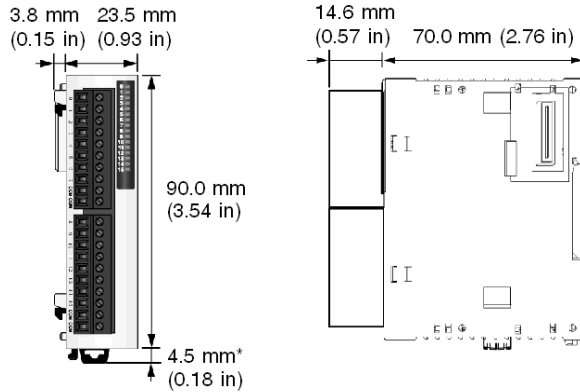

**NOTE:** \* 8.5 mm (0.33 in) when the clamp is pulled out.

**Discrete I/O Module (16 In and 8 Out)**

The following diagrams show the dimensions for the TWDDMM24DRF discrete I/O module.

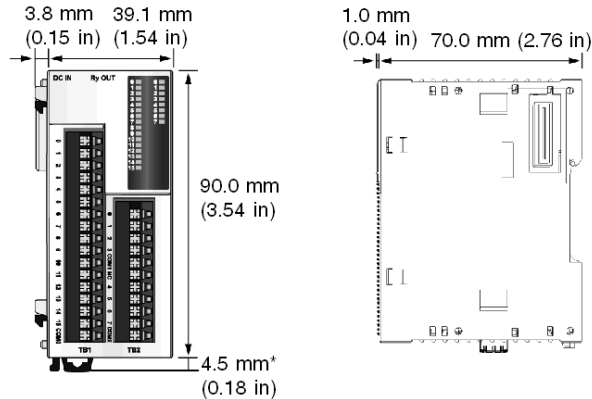

**NOTE:** \* 8.5 mm (0.33 in) when the clamp is pulled out.

**Discrete I/O Modules (16 In or Out with a Connector)**

The following diagrams show the dimensions for the TWDDDI16DK, TWDDDO16TK, and TWDDDO16UK discrete I/O modules.

Illustrations showing a TWDDDI16DK module:

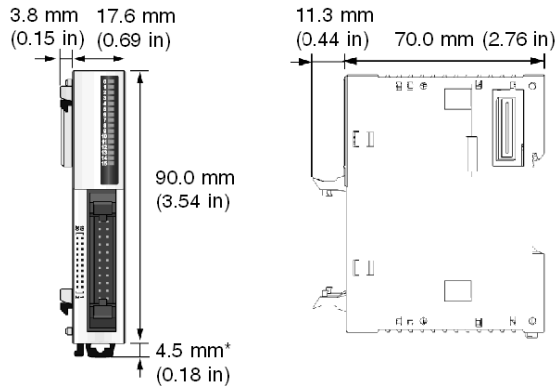

**NOTE:** \* 8.5 mm (0.33 in) when the clamp is pulled out.

**Discrete I/O Modules (32 In or Out)**

The following diagrams show the dimensions for the TWDDDI32DK, TWDDDO32TK, and TWDDDO32UK discrete I/O modules.

Illustrations showing a TWDDDI32DK module:

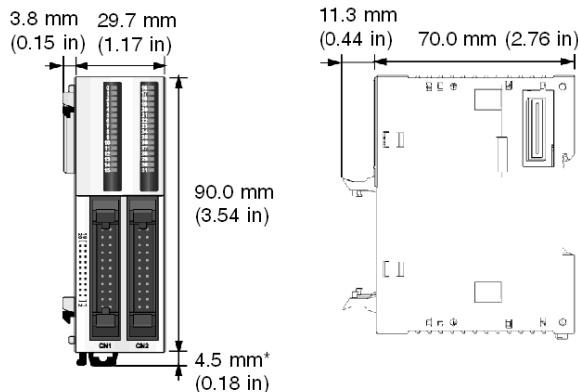

**NOTE:** \* 8.5 mm (0.33 in) when the clamp is pulled out.

## How to Directly Mount a TWD Discrete I/O Module on a Panel Surface

### Introduction

This section shows how to install mounting strips directly on discrete I/O modules. This section also provides mounting hole layouts for each module. Your module may differ from the illustrations in these procedures but the basic mechanism procedures are applicable.

### Installing a Mounting Strip

The following procedure shows how to install a mounting strip.

Step	Action
1	Remove the clamp from the back side of the module by pushing the clamp inward.
2	Insert the mounting strip, with the hook entering last, into the slot where the clamp was removed.
3	Slide the mounting strip into the slot until the hook enters into the recess in the module.



### Mounting Hole Layout for Discrete I/O Modules

The following diagram shows the mounting hole layout for the discrete I/O modules.

TWDDDI8DT  
 TWDDAI8DT  
 TWDDDI16DT  
 TWDDRA8RT  
 TWDDRA16RT  
 TWDDDO8UT  
 TWDDDO8TT  
 TWDDMM8DRT

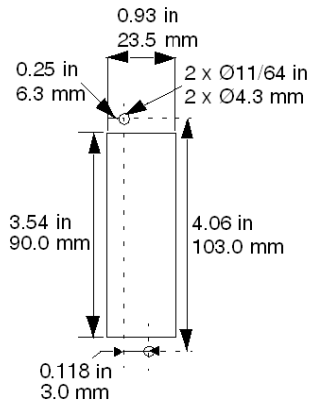

TWDDDI16DK  
 TWDDDO16TK  
 TWDDDO16UK

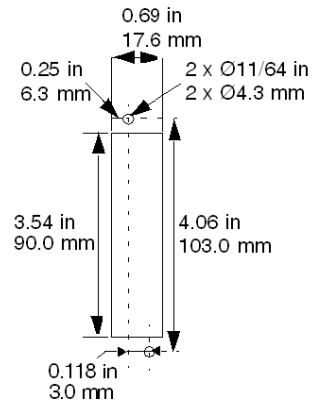

TWDDDI32DK  
 TWDDDO32TK  
 TWDDDO32UK

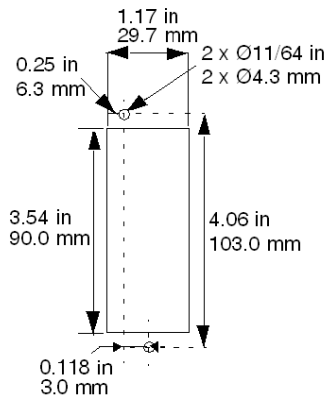

TWDDMM24DRF

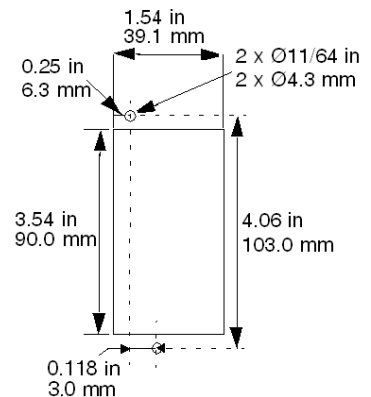

## How to Install and Remove a TWD Discrete I/O Module from a DIN Rail

### Introduction

This section describes how to install and remove discrete I/O modules from a DIN rail. The device you want to install or remove may differ from the illustrations in these procedures but the basic mechanism procedures are applicable.

**NOTE:** When mounting discrete I/O modules on a DIN rail, use two end stops, type AB1-AB8P35 or equivalent.

For additional information, refer DIN rail (*see page 91*).

### How to Install a Discrete I/O Module on a DIN Rail

The following procedure shows how to install a discrete I/O module on a DIN rail.

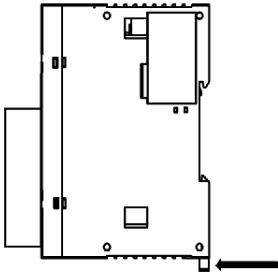
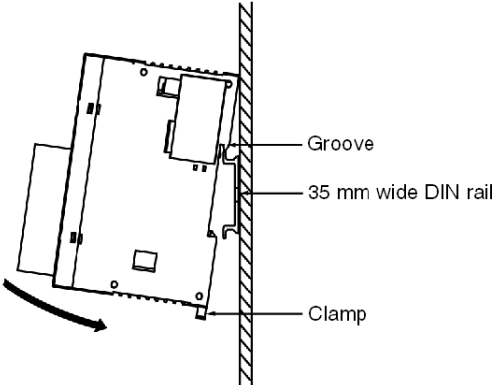
Step	Action
1	Fasten the DIN rail to a panel using screws.
2	Pull out the clamp at the bottom of the base and module assembly. 
3	Put the top groove of the compact base and module on the DIN rail and press the modules toward the DIN rail. 

Step	Action
4	Push the clamp into the DIN rail.
5	Place mounting clips on both sides of the modules to keep the system from moving sideways.

### How to Remove a Discrete I/O Module from a DIN Rail

The following procedure shows how to remove a discrete I/O module from a DIN rail.

Step	Action
1	Insert a flat screwdriver into the slot in the clamp.
2	Pull out the clamp.
3	Pull the compact base and the associated module off the DIN rail from the bottom.

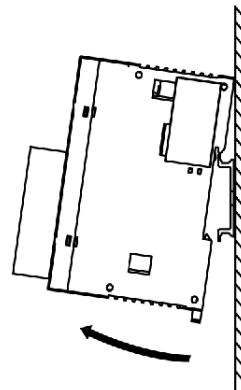
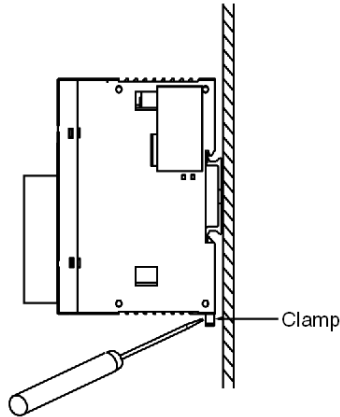



---

# Description of TWD Discrete I/O Modules

# 3

---

## Introduction

This chapter provides descriptions, overviews, parts, specifications, wiring rules and recommendations, and wiring schematics for the Twido Discrete I/O modules.

## What's in this Chapter?

This chapter contains the following sections:

Section	Topic	Page
3.1	TWD Discrete I/O Modules Description	38
3.2	Wiring Rules and Recommendations for TWD Discrete I/O Modules	44
3.3	Specifications and Wiring Diagrams for TWD Discrete Input Modules	49
3.4	Specifications and Wiring Diagrams for TWD Relay Output Modules	62
3.5	Specifications and Wiring Diagrams for TWD Transistor Output Modules	69
3.6	Specifications and Wiring Diagrams for TWD Discrete Mixed I/O Modules	79

## 3.1 TWD Discrete I/O Modules Description

---

### Introduction

This section provides an overview and a parts description of the TWD Discrete I/O modules.

### What's in this Section?

This section contains the following topics:

Topic	Page
Overview of TWD Discrete I/O Modules	39
Parts Description of TWD Discrete I/O Modules	42

## Overview of TWD Discrete I/O Modules





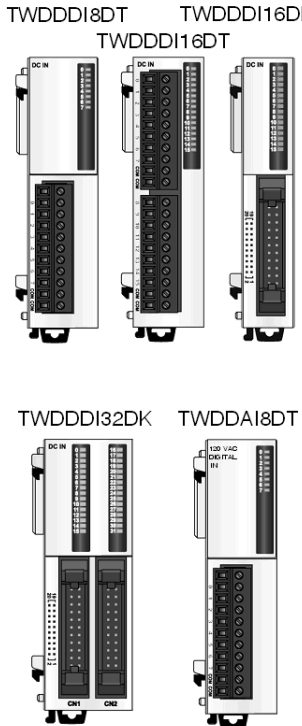

### Introduction

The following section provides an overview of the TWD discrete I/O modules.

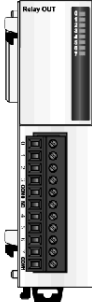
### Illustrations

The following illustrations are the discrete input, output, and mixed I/O modules.

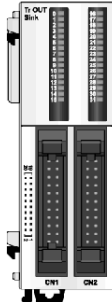
Model Type	Illustration
<p>There are 5 discrete input modules:</p> <ul style="list-style-type: none"> <li>● 8-point module with a terminal block (TWDDDI8DT)</li> <li>● 16-point module with a terminal block (TWDDDI16DT)</li> <li>● 16-point module with a connector (TWDDDI16DK)</li> <li>● 32-point module with a connector (TWDDDI32DK)</li> <li>● 8-point, 120 VAC input module with a terminal block (TWDDAI8DT)</li> </ul> <p>These modules can be attached to any controller except the Compact 10 I/O and 16 I/O controllers.</p>	 <p>The illustration shows five discrete input modules arranged in two rows. The top row contains three modules: TWDDDI8DT (8-point terminal block), TWDDDI16DK (16-point connector), and TWDDDI16DT (16-point terminal block). The bottom row contains two modules: TWDDDI32DK (32-point connector) and TWDDAI8DT (8-point 120 VAC terminal block). Each module is a vertical rack-mountable unit with a handle on the left and a terminal block or connector on the front panel. Labels for 'DC IN' and '120 VAC DIGITAL IN' are visible on the modules.</p>

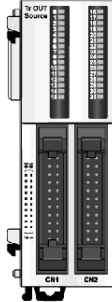
Model Type	Illustration
<p>There are 8 discrete output modules:</p> <ul style="list-style-type: none"> <li>● 8-point relay output module with a terminal block (TWDDRA8RT)</li> <li>● 16-point relay output module with a terminal block (TWDDRA16RT)</li> <li>● 8-point transistor sink module with a connector (TWDDDO8UT)</li> <li>● 16-point transistor sink module with a connector (TWDDDO16UK)</li> <li>● 32-point transistor sink module with a connector (TWDDDO32UK)</li> <li>● 8-point transistor source module with a terminal block (TWDDDO8TT)</li> <li>● 16-point transistor source module with a connector (TWDDDO16TK)</li> <li>● 32-point transistor source module with a connector (TWDDDO32TK)</li> </ul> <p>These modules can be attached to any controller except the Compact 10 I/O and 16 I/O controllers.</p>	<div style="display: flex; justify-content: space-around; align-items: flex-start;"> <div style="text-align: center;"> <p>TWDDRA8RT</p>  </div> <div style="text-align: center;"> <p>TWDDRA16RT</p>  </div> </div> <div style="display: flex; justify-content: space-around; align-items: flex-start; margin-top: 20px;"> <div style="text-align: center;"> <p>TWDDDO8UT</p>  </div> <div style="text-align: center;"> <p>TWDDDO16UK</p>  </div> <div style="text-align: center;"> <p>TWDDDO32UK</p>  </div> </div> <div style="display: flex; justify-content: space-around; align-items: flex-start; margin-top: 20px;"> <div style="text-align: center;"> <p>TWDDDO8TT</p>  </div> <div style="text-align: center;"> <p>TWDDDO16TK</p>  </div> <div style="text-align: center;"> <p>TWDDDO32TK</p>  </div> </div>

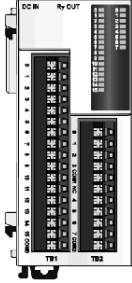

Model Type	Illustration
<p>There are 2 discrete mixed input and output modules:</p> <ul style="list-style-type: none"> <li>● 4-point input/4-point output module with a terminal block (TWDDMM8RT)</li> <li>● 16-point input/8-point output module with a wire-clamp terminal block (TWDDMM24DRF)</li> </ul> <p>These modules can be attached to any controller except the Compact 10 I/O and 16 I/O controllers.</p>	<div style="display: flex; justify-content: space-around; align-items: flex-start;"> <div style="text-align: center;"> <p>TWDDMM8RT</p>  </div> <div style="text-align: center;"> <p>TWDDMM24DRF</p>  </div> </div>

## Parts Description of TWD Discrete I/O Modules

### Introduction

The following section describes the parts of a discrete I/O module with a terminal block and with a connector. Your I/O module may differ from the illustrations but the parts will be the same.

### Parts Description of a Discrete I/O Module with a Terminal Block

The following picture shows the parts of a discrete I/O module with a terminal block. This figure is the TWDDDI8DT module.

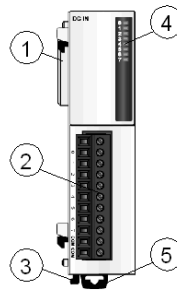

### Caption

Label	Description
1	Expansion connector - one on each side, right side not shown
2	Terminal block
3	Latch button
4	LEDs
5	Clamp

**Parts Description of a Discrete I/O Module with a Connector**

The following picture shows the parts of a discrete I/O module with a connector. This figure is the TWDDDO16TK module.

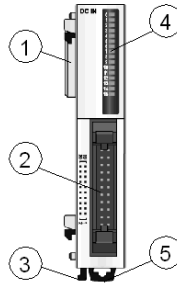
**Caption**

Label	Description
1	Expansion connector - one on each side, right side not shown
2	Connector
3	Latch button
4	LEDs
5	Clamp

## 3.2 Wiring Rules and Recommendations for TWD Discrete I/O Modules

---

### Wiring Rules and Recommendations for Discrete I/O Modules

#### Introduction

There are several rules that must be followed when wiring a discrete I/O module. Recommendations, when needed, are provided on how to comply with the rules.

#### **DANGER**

##### **HAZARD OF ELECTRIC SHOCK, EXPLOSION OR ARC FLASH**

- Disconnect all power from all equipment including connected devices prior to removing any covers or doors, or installing or removing any accessories, hardware, cables, or wires except under the specific conditions specified in the appropriate hardware guide for this equipment.
- Always use a properly rated voltage sensing device to confirm the power is off where and when indicated.
- Replace and secure all covers, accessories, hardware, cables, and wires and confirm that a proper ground connection exists before applying power to the unit.
- Use only the specified voltage when operating this equipment and any associated products.

**Failure to follow these instructions will result in death or serious injury.**

#### **WARNING**

##### **MALFUNCTION OF OUTPUTS**

Use appropriate safety interlocks where personal and/or equipment hazards exist. Outputs can malfunction and remain ON or OFF.

**Failure to follow these instructions can result in death, serious injury, or equipment damage.**

## Rules

- Each terminal accepts up to two 18 AWG (0.82 mm<sup>2</sup>) through 28 AWG (0.08 mm<sup>2</sup>) fitted with cable ends or tags.
- The power supply wire are to be between 18 AWG (0.82 mm<sup>2</sup>) and 22 AWG (0.33 mm<sup>2</sup>). Use the shortest wire length possible.
- The grounding wire is to be 16 AWG (1.30 mm<sup>2</sup>).
- Power supply wires routed inside the panel must be kept separate from power wires, I/O wiring and communication wiring. Route wiring in separate cable ducting.
- Verify that the operating conditions and environments are within the specification values.
- Use proper wire size to meet voltage and current requirements.

## Terminal Tightening Torque

Recommended tightening torque of terminal blocks is listed for all products on the product label.

## Input Operating Range

The input operating range of the Type 1 (IEC 61131-2) input module is shown below.

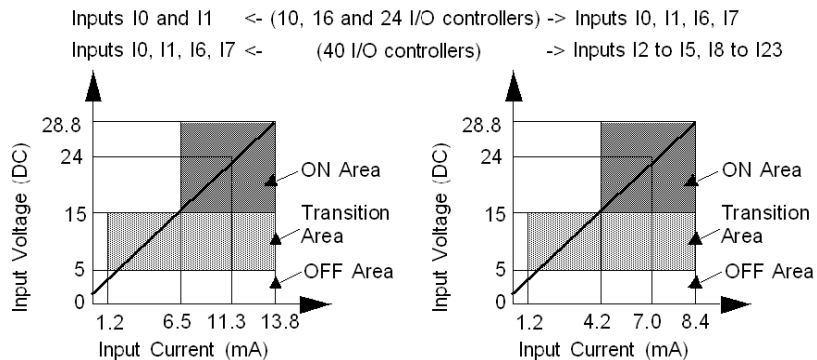

## Input Internal Circuit

The input internal circuit is shown below.

### Latching or High Speed Sink or Source Inputs

Inputs I0 and I1 <- (10, 16 and 24 I/O controllers) -> Inputs I0, I1, I6, I7

Inputs I0, I1, I6, I7 <- (40 I/O controllers) -> Inputs I2 to I5, I8 to I23

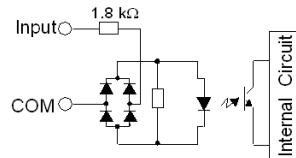

### Standard Sink or Source Input

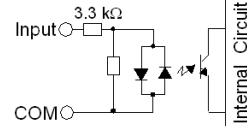

## Contact Protection Circuit for Relay and Transistor Outputs

### CAUTION

#### POTENTIAL MODULE DAMAGE

Inductive loads are capable of inducing high voltages that can damage or reduce the operating life of modules outputs. When driving inductive loads one of the following protective circuits must be used. Ensure by calculation, simulation or test that the circuit chosen is capable of absorbing the inductive energy without exceeding the module ratings.

**Failure to follow these instructions can result in injury or equipment damage.**

Depending on the load, a protection circuit may be needed for the relay output on the bases. Choose a protection circuit, from the following diagrams, according to the power supply. Connect the protection circuit to the outside of the base or relay output module.

Protective circuit A: this protection circuit can be used when the load impedance is smaller than the RC impedance in an AC load power circuit.

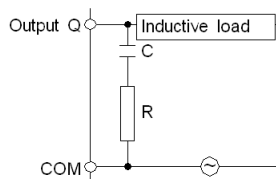

- C represents a value from 0.1 to 1  $\mu\text{F}$ .
- R represents a resistor of approximately the same resistance value as the load.

**Protective circuit B:** this protection circuit can be used for both AC and DC load power circuits.

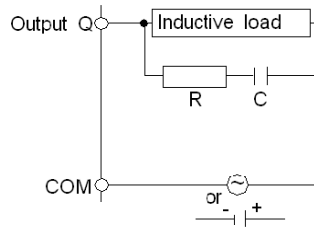

- C represents a value from 0.1 to 1  $\mu\text{F}$ .
- R represents a resistor of approximately the same resistance value as the load.

**Protective circuit C:** this protection circuit can be used for DC load power circuits.

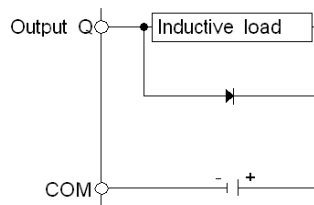

Use a diode with the following ratings:

- Reverse withstand voltage: power voltage of the load circuit x 10.
- Forward current: more than the load current.

**Protective circuit D:** this protection circuit can be used for both AC and DC load power circuits.

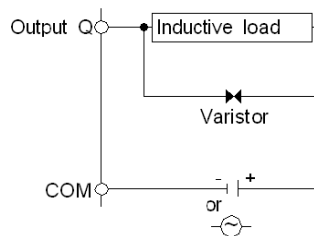

### Explanation of Source Inputs/Sink Outputs

**NOTE: Sink** corresponds to the sensors' common on the (+) terminal of the power supply.

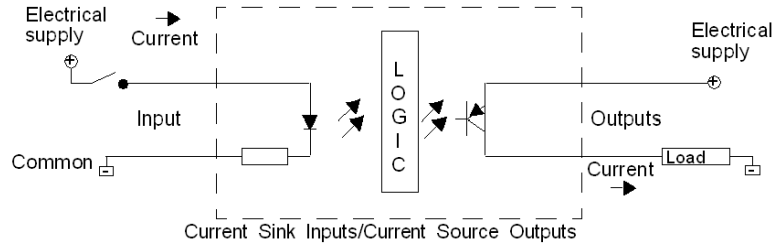

Input side COM field terminal connects to the "-" terminal or common of the field power supply. Output side COM field terminal connects to +24V field power supply.

### Explanation of Sink Inputs/Source Outputs

**NOTE: Source** corresponds to the sensors' common on the (-) terminal of the power supply.

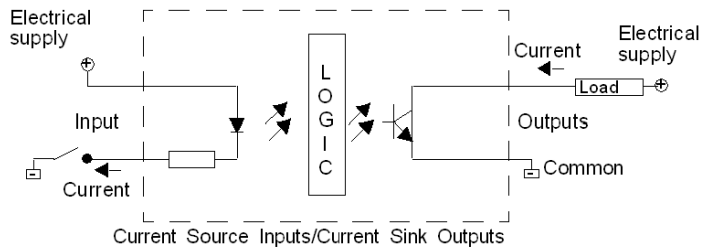

Input side COM field terminal connects to +24V field power supply. Output side COM field terminal connects to the "-" terminal or common of the field power supply.



---

## 3.3 Specifications and Wiring Diagrams for TWD Discrete Input Modules

---

### Introduction

This section provides general, electrical, input and functional specifications, and wiring diagrams description for TWD Discrete Input modules.

### What's in this Section?

This section contains the following topics:

Topic	Page
General Specifications for the TWD Discrete Input Modules	50
Electrical Specifications for the TWD Discrete Input Modules	51
Input Specifications for the TWD Discrete Input Modules	52
TWD Discrete Input Modules Wiring Diagrams	55

## General Specifications for the TWD Discrete Input Modules

### Introduction

This section presents the general specifications for the TWD discrete input modules.

### TWDDI8DT, TWDDI16DT, TWDDI16DK, TWDDI32DK and TWDDAI8DT Normal Operating Specifications

## ⚠ WARNING

### UNINTENDED EQUIPMENT OPERATION

Do not exceed any of the rated values specified below.

**Failure to follow these instructions can result in death, serious injury, or equipment damage.**

Reference number	Discrete Input Modules				
	TWDDI8DT	TWDDI16DT	TWDDI16DK	TWDDI32DK	TWDDAI8DT
Ambient operating temperature	0°C to 55°C (32°F to 131°F)				
Storage temperature (°C)	- 25°C to +70°C (-13°F to +158°F)				
Relative humidity	30 to 95% (non-condensing)				
Degree of pollution	2 (IEC60664)				
Degree of protection	IP 20				
Corrosion immunity	Free from corrosive gases				
Altitude	Operation: 0 to 2,000 m (0 to 6,560 ft) Transport: 0 to 3,000 m (0 to 9,840 ft)				
Resistance to vibration	When mounted on a DIN rail: 10 to 57 Hz, amplitude 0.075 mm, 57 to 150 Hz, acceleration 9.8 m/s <sup>2</sup> (1G) When mounted on a panel surface: 2 to 25 Hz, amplitude 1.6 mm, 25 to 100 Hz, acceleration 39.2 m/s <sup>2</sup> (4G)				
Impact strength	147 m/s <sup>2</sup> (15G) for 11ms duration				
Weight	85 g (3 oz)	100 g (3.5 oz)	65 g (2.3 oz)	100 g (3.5 oz)	81 g (2.9 oz)

## Electrical Specifications for the TWD Discrete Input Modules

### Introduction

This section presents the electrical specifications for the TWD discrete input modules.

### TWDDDI8DT, TWDDDI16DT, TWDDDI16DK, TWDDDI32DK and TWDDAI8DT Electrical Specifications

## WARNING

### UNINTENDED EQUIPMENT OPERATION

Do not exceed any of the rated values specified below.

**Failure to follow these instructions can result in death, serious injury, or equipment damage.**

Reference number	Discrete Input Modules				
	TWDDDI8DT	TWDDDI16DT	TWDDDI16DK	TWDDDI32DK	TWDDAI8DT
Isolation	Between input terminals and internal circuit: photocoupler isolated (isolation protection up to 500 V) Between input terminals: not isolated				
Connector insertion/removal durability	100 times minimum				
Internal current draw - all inputs on	25 mA (5 VDC) 0 mA (24 VDC)	40 mA (5 VDC) 0 mA (24 VDC)	35 mA (5 VDC) 0 mA (24 VDC)	65 mA (5 VDC) 0 mA (24 VDC)	55 mA (5 VDC) 0 mA (24 VDC)
Internal current draw - all inputs off	5 mA (5 VDC) 0 mA (24 VDC)	5 mA (5 VDC) 0 mA (24 VDC)	5 mA (5 VDC) 0 mA (24 VDC)	10 mA (5 VDC) 0 mA (24 VDC)	25 mA (5 VDC) 0 mA (24 VDC)

## Input Specifications for the TWD Discrete Input Modules

### Introduction

This section presents the input specifications for the TWD discrete input modules.

### TWDDDI8DT, TWDDDI16DT, TWDDDI16DK, TWDDDI32DK and TWDDAI8DT Specifications

#### WARNING

##### UNINTENDED EQUIPMENT OPERATION

Do not exceed any of the rated values specified below.

**Failure to follow these instructions can result in death, serious injury, or equipment damage.**

Reference number	Discrete Input Modules				
	TWDDDI8DT	TWDDDI16DT	TWDDDI16DK	TWDDDI32DK	TWDDAI8DT
Input points	8	16	16	32	8
Common lines	1	1	1	2	2
Rated input voltage	24 VDC source/sink input signal				120 VAC
Input voltage range	from 20.4 to 28.8 VDC				132 VAC max
Rated input current	7 mA/input (24 VDC)		5 mA/input (24 VDC)		7.5 mA/input (100 VAC)
Input impedance	3.4 k $\Omega$		4.4 k $\Omega$		11 k $\Omega$
Turn on time	8 ms (24 VDC)				25 ms (120 VAC)
Turn off time	8 ms (24 VDC)				30 ms (120 VAC)
Isolation	Between input terminals and internal circuit: photocoupler isolated (isolation protection up to 500 VAC) Between input terminals: not isolated				
External load for I/O interconnection	Not needed				
Signal determination method	Static				
Input signals type	The input signals can be both sink and source.				The input signals must be of AC type.
Cable length	3m (9.84 ft.)				

Reference number	Discrete Input Modules				
	TWDDDI8DT	TWDDDI16DT	TWDDDI16DK	TWDDDI32DK	TWDDAI8DT
Connector insertion/removal durability	100 times minimum				
Internal current draw - all inputs on	25 mA (5 VDC) 0 mA (24 VDC)	40 mA (5 VDC) 0 mA (24 VDC)	35 mA (5 VDC) 0 mA (24 VDC)	65 mA (5 VDC) 0 mA (24 VDC)	55 mA (5 VDC) 0 mA (24 VDC)
Internal current draw - all inputs off	5 mA (5 VDC) 0 mA (24 VDC)	5 mA (5 VDC) 0 mA (24 VDC)	5 mA (5 VDC) 0 mA (24 VDC)	10 mA (5 VDC) 0 mA (24 VDC)	25 mA (5 VDC) 0 mA (24 VDC)
Weight	85 g (3 oz)	100 g (3.5 oz)	65 g (2.3 oz)	100 g (3.5 oz)	81 g (2.9 oz)

### TWDDDI8DT, TWDDDI16DT, TWDDDI16DK, TWDDDI32DK and TWDDAI8DT Internal Circuit

The input internal circuit is shown below.

#### Standard Sink or Source Input

TWDDDI8DT and TWDDDI16DT

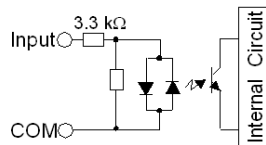

TWDDDI16DK and TWDDDI32DK

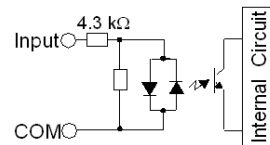

TWDDAI8DT

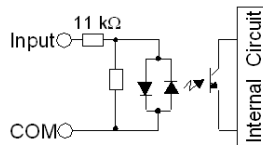

**TWDDDI8DT, TWDDDI16DT, TWDDDI16DK, TWDDDI32DK and TWDDAI8DT Usage Limits**

When using TWDDDI16DT at 55°C (131°F) in the normal mounting direction, limit the inputs which turn on simultaneously along line (1). At 45°C (113°F), all inputs can be turned on simultaneously at 28.8 VDC as indicated with line (2).

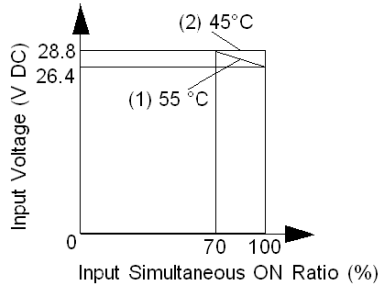

When using TWDDDI16DK and TWDDDI32DK at 55°C (131°F), limit the inputs which turn on simultaneously on each connector along line (3). This limitation applies per connector. At 30°C (86°F), all inputs can be turned on simultaneously at 28.8 VDC as indicated with line (4).

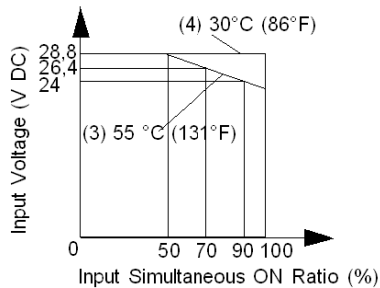

When using TWDDDI8DT, all inputs can be turned on simultaneously at 55°C (131°F), input voltage 28.8 VDC.

## TWD Discrete Input Modules Wiring Diagrams

### Introduction

This section shows examples of wiring diagrams for the TWD discrete input modules. Symbols used in the following diagrams are explained in the Glossary of Symbols (*see page 93*) in the appendix.

### DANGER

#### HAZARD OF ELECTRIC SHOCK, EXPLOSION OR ARC FLASH

- Disconnect all power from all equipment including connected devices prior to removing any covers or doors, or installing or removing any accessories, hardware, cables, or wires except under the specific conditions specified in the appropriate hardware guide for this equipment.
- Always use a properly rated voltage sensing device to confirm the power is off where and when indicated.
- Replace and secure all covers, accessories, hardware, cables, and wires and confirm that a proper ground connection exists before applying power to the unit.
- Use only the specified voltage when operating this equipment and any associated products.

**Failure to follow these instructions will result in death or serious injury.**

**NOTE:** These diagrams are for external wiring only.

**NOTE:** The shaded boxes are markings on the discrete input modules. The I and Q numbers are the input and output points.

### TWDDDI8DT Wiring Diagram

This diagram is for the TWDDDI8DT module.

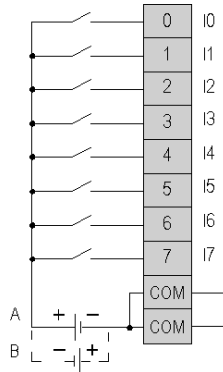

- The two COM terminals are connected together internally.
- Both sink and source input wiring are supported
- A is the sink wiring (positive logic).
- B is the source wiring (negative logic).

### TWDDAI8DT Wiring Diagram

**DANGER**

**HAZARD OF ELECTRIC SHOCK, EXPLOSION OR ARC FLASH**

- Disconnect all power from all equipment including connected devices prior to removing any covers or doors, or installing or removing any accessories, hardware, cables, or wires except under the specific conditions specified in the appropriate hardware guide for this equipment.
- Always use a properly rated voltage sensing device to confirm the power is off where and when indicated.
- Replace and secure all covers, accessories, hardware, cables, and wires and confirm that a proper ground connection exists before applying power to the unit.
- Use only the specified voltage when operating this equipment and any associated products.

**Failure to follow these instructions will result in death or serious injury.**



This diagram is for the TWDDAI8DT module.

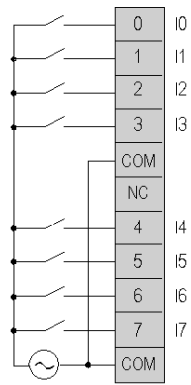

120 VAC input wiring

- The two COM terminals are **not** connected together internally.

### TWDDDI16DT Wiring Diagram

This diagram is for the TWDDDI16DT module.

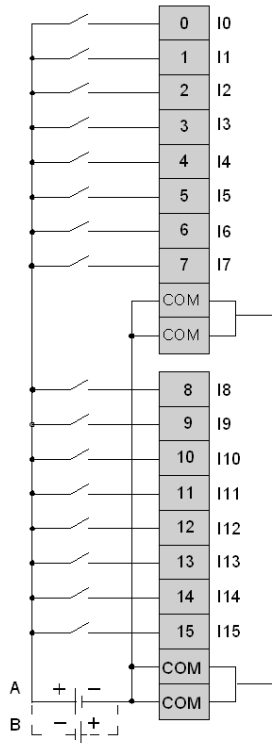

- The four COM terminals are connected together internally.
- Both sink and source input wiring are supported
- A is the sink wiring (positive logic).
- B is the source wiring (negative logic).

## TWDDDI16DK Wiring Diagram

This diagram is for the TWDDDI16DK module.

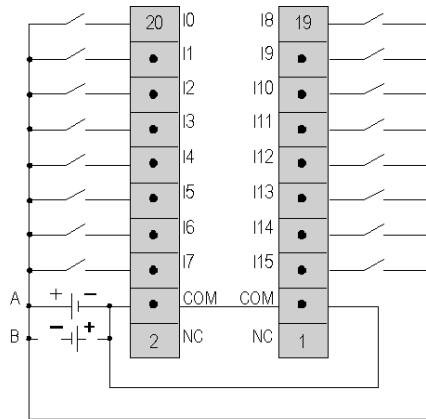

- The two COM terminals are connected together internally.
- Both sink and source input wiring are supported
- A is the sink wiring (positive logic).
- B is the source wiring (negative logic).

## TWDDDI32DK Wiring Diagram

This diagram is for the TWDDDI32DK module.

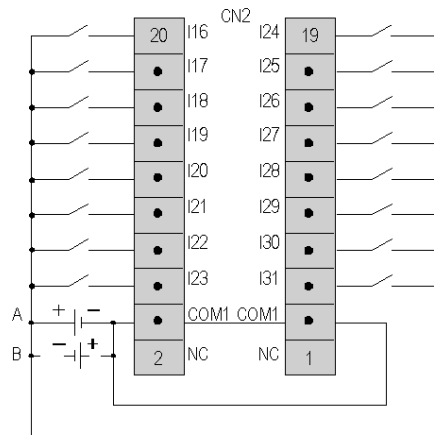
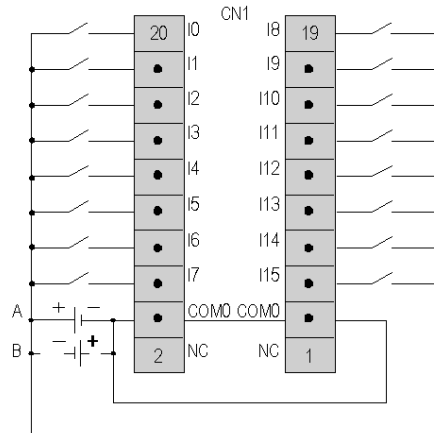

- The COM0 terminals are connected together internally.
- The COM1 terminals are connected together internally.
- The COM0 and COM1 terminals are **not** connected together internally.
- Both sink and source input wiring are supported
- A is the sink wiring (positive logic).
- B is the source wiring (negative logic).

**TWDDDI8DT, TWDDDI16DT, TWDDDI16DK, TWDDDI32DK and TWDDAI8DT Operating Range**

The operating range of the Type 1 (IEC 61131-2) input module is shown below.

TWDDDI8DT and TWDDDI16DT

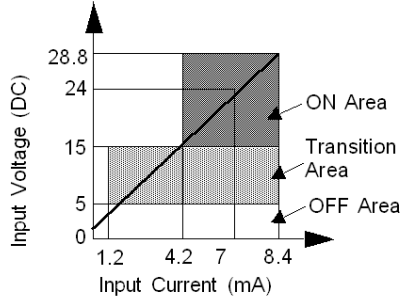

TWDDDI16DK and TWDDDI32DK

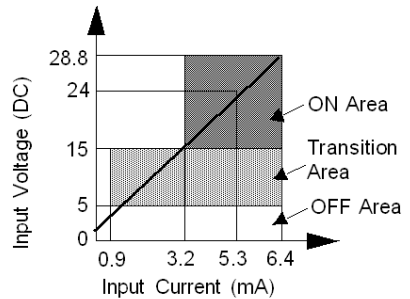

TWDDAI8DT

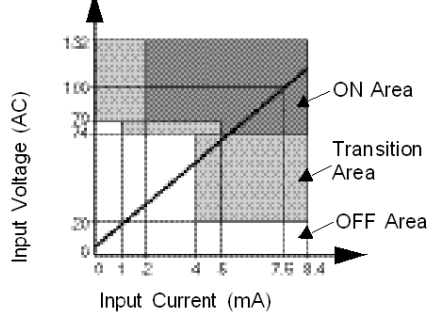

## 3.4 Specifications and Wiring Diagrams for TWD Relay Output Modules

---

### Introduction

This section provides general, electrical, relay output, and functional specifications for TWD Relay Output modules.

### What's in this Section?

This section contains the following topics:

Topic	Page
General Specifications for the TWD Relay Output Modules	63
Electrical Specifications for the TWD Relay Output Modules	64
Output Specifications for the TWD Relay Output Modules	65
TWD Relay Output Modules Wiring Diagrams	66

## General Specifications for the TWD Relay Output Modules

### Introduction

This section presents the general specifications for the TWD relay output modules.

### TWDDRA8RT and TWDDRA16RT Specifications

#### WARNING

##### UNINTENDED EQUIPMENT OPERATION

Do not exceed any of the rated values specified below.

**Failure to follow these instructions can result in death, serious injury, or equipment damage.**

Reference number	Relay Output Modules	
	TWDDRA8RT	TWDDRA16RT
Ambient operating temperature	0°C to 55°C (32°F to 131°F)	
Storage temperature (°C)	- 25°C to +70°C (-13°F to +158°F)	
Relative humidity	30 to 95% (non-condensing)	
Degree of pollution	2 (IEC60664)	
Degree of protection	IP 20	
Corrosion immunity	Free from corrosives gases	
Altitude	Operation: 0 to 2,000 m (0 to 6,560 ft) Transport: 0 to 3,000 m (0 to 9,840 ft)	
Resistance to vibration	When mounted on a DIN rail: 10 to 57 Hz, amplitude 0.075 mm, 57 to 150 Hz, acceleration 9.8 m/s <sup>2</sup> (1G) When mounted on a panel surface: 2 to 25 Hz, amplitude 1.6 mm, 25 to 100 Hz, acceleration 39.2 m/s <sup>2</sup> (4G)	
Impact strength	147 m/s <sup>2</sup> (15G) for 11ms duration	
Weight	110 g (3.9 oz)	145 g (5.1 oz)

## Electrical Specifications for the TWD Relay Output Modules

### Introduction

This section presents the electrical specifications for the TWD relay output modules.

### TWDDRA8RT and TWDDRA16RT Specifications

## ! DANGER

**FIRE HAZARDS**

Possible current overload; size wire accordingly.

**Failure to follow these instructions will result in death or serious injury.**

Reference number	Relay Output Modules	
	TWDDRA8RT	TWDDRA16RT
Connector insertion/removal durability	100 times minimum	
Internal current draw - all outputs on	30 mA (5 VDC) 40mA (24 VDC)	45 mA (5 VDC) 75 mA (24 VDC)
Internal current draw - all outputs off	5 mA (5 VDC) 0 mA (24 VDC)	5 mA (5 VDC) 0 mA (24 VDC)
Weight	110 g (3.9 oz)	145 g (5.1 oz)

### Relay Output Contact

The relay output contact is shown below.

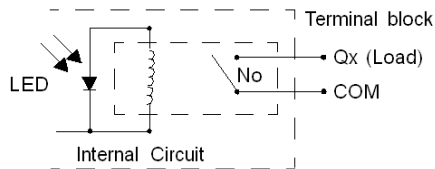



## Output Specifications for the TWD Relay Output Modules

### Introduction

This section presents the output specifications for the TWD relay output modules.

### TWDDRA8RT and TWDDRA16RT Specifications

## ⚠ DANGER

### FIRE HAZARDS

Possible current overload; size wire accordingly.

**Failure to follow these instructions will result in death or serious injury.**

Reference number	Relay Output Modules	
	TWDDRA8RT	TWDDRA16RT
Output points and common lines	8 NO contacts in 2 common lines	16 NO contacts in 2 common lines
Maximum load current	2 A per output	
	7 A per common line	8 A per common line
Minimum switching load	0.1 mA/0.1 VDC (reference value)	
Initial contact resistance	30 mΩ maximum	
Electrical life	100,000 operations minimum (rated resistive load 1,800 operations/h)	
Mechanical life	20,000,000 operations minimum (no load 18,000 operations/h)	
Rated load (resistive/inductive)	240 VAC/2 A, 30 VDC/2 A	
Dielectric strength	Between output to terminals: 1500 VAC, 1 minute Between output terminal and internal circuit: 1500 VAC, 1 minute Between output groups: 1500 VAC, 1 minute	

### TWDDRA8RT and TWDDRA16RT Delay

The output delay is shown below.

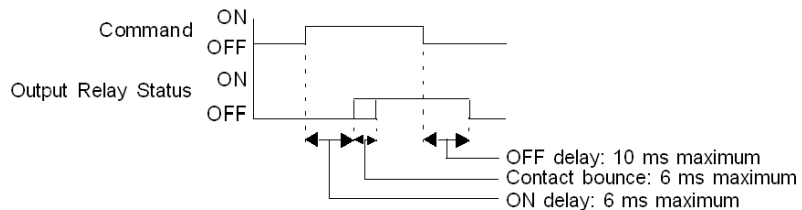

## TWD Relay Output Modules Wiring Diagrams

### Introduction

This section shows examples of wiring diagrams for the TWD relay output modules. Symbols used in the following diagrams are explained in the Glossary of Symbols (*see page 93*) in the appendix.

 <b>DANGER</b>
<b>HAZARD OF ELECTRIC SHOCK, EXPLOSION OR ARC FLASH</b>
<ul style="list-style-type: none"><li>● Disconnect all power from all equipment including connected devices prior to removing any covers or doors, or installing or removing any accessories, hardware, cables, or wires except under the specific conditions specified in the appropriate hardware guide for this equipment.</li><li>● Always use a properly rated voltage sensing device to confirm the power is off where and when indicated.</li><li>● Replace and secure all covers, accessories, hardware, cables, and wires and confirm that a proper ground connection exists before applying power to the unit.</li><li>● Use only the specified voltage when operating this equipment and any associated products.</li></ul>
<b>Failure to follow these instructions will result in death or serious injury.</b>

 <b>WARNING</b>
<b>UNINTENDED EQUIPMENT OPERATION</b>
Use appropriate safety interlocks where personal and/or equipment hazards exist.
<b>Failure to follow these instructions can result in death, serious injury, or equipment damage.</b>

**NOTE:** These diagrams are for external wiring only.

**NOTE:** The shaded boxes are markings on the discrete I/O modules. The I and Q numbers are the input and output points.

## TWDDRA8RT Wiring Diagram

This diagram is for the TWDDRA8RT module.

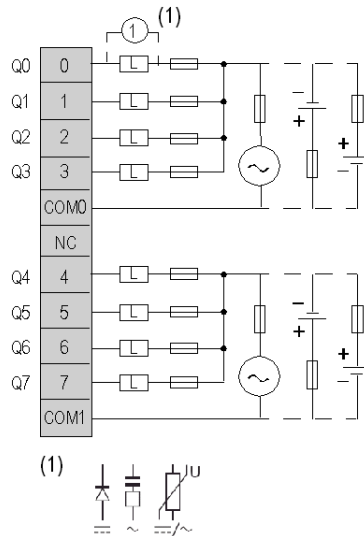

- The COM0 and COM1 terminals are **not** connected together internally.
- Connect an appropriate fuse for the load.
- (1) is the protection for inductive load.

### TWDDRA16RT Wiring Diagram

This diagram is for the TWDDRA16RT module.

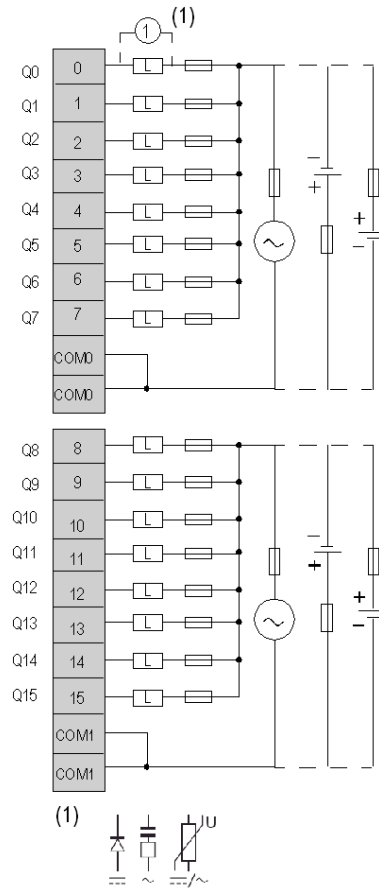

- The COM0 terminals are connected together internally.
- The COM1 terminals are connected together internally.
- The COM0 and COM1 terminals are **not** connected together internally.
- Connect an appropriate fuse for the load.
- (1) is the protection for inductive load.

---

## 3.5 Specifications and Wiring Diagrams for TWD Transistor Output Modules

---

### Introduction

This section provides general, electrical, output, and functional specifications for TWD Transistor Output modules.

### What's in this Section?

This section contains the following topics:

Topic	Page
General Specifications for the TWD Transistor Output Modules	70
Electrical Specifications for the TWD Transistor Output Modules	71
Output Specifications for the TWD Transistor Output Modules	72
TWD Transistor Output Module Wiring Diagrams	74

## General Specifications for the TWD Transistor Output Modules

### Introduction

This section presents the general specifications for the TWD transistor output modules.

### TWDDDO8UT, TWDDDO16UK, TWDDDO32UK, TWDDDO8TT, TWDDDO16TK, and TWDDDO32TK Specifications

 <b>DANGER</b>			
<b>FIRE HAZARDS</b>			
Possible current overload; size wire accordingly.			
<b>Failure to follow these instructions will result in death or serious injury.</b>			

Reference number	TWDDDO8UT TWDDDO8TT	TWDDDO16UK TWDDDO16TK	TWDDDO32UK TWDDDO32TK
Output type	TWDDDO8UT, TWDDDO16UK and TWDDDO32UK are transistor sink outputs TWDDDO8TT, TWDDDO16TK and TWDDDO32TK are transistor source outputs		
Ambient operating temperature	0°C to 55°C (32°F to 131°F)		
Storage temperature	- 25°C to +70°C (-13°F to +158°F)		
Relative humidity	30 to 95% (non-condensing)		
Degree of pollution	2 (IEC60664)		
Degree of protection	IP 20		
Corrosion immunity	Free from corrosive gases		
Altitude	Operation: 0 to 2,000 m (0 to 6,560 ft) Transport: 0 to 3,000 m (0 to 9,840 ft)		
Resistance to vibration	When mounted on a DIN rail: 10 to 57 Hz, amplitude 0.075 mm, 57 to 150 Hz, acceleration 9.8 m/s <sup>2</sup> (1G) When mounted on a panel surface: 2 to 25 Hz, amplitude 1.6 mm, 25 to 100 Hz, acceleration 39.2 m/s <sup>2</sup> (4G)		
Impact strength	147 m/s <sup>2</sup> (15G) for 11ms duration		
Weight	85 g (3 oz)	70 g (2.5 oz)	105 g (3.7 oz)

## Electrical Specifications for the TWD Transistor Output Modules

### Introduction

This section presents the electrical specifications for the TWD transistor output modules.

### TWDDDO8UT, TWDDDO16UK, TWDDDO32UK, TWDDDO8TT, TWDDDO16TK, and TWDDDO32TK Electrical Specifications

Reference number	TWDDDO8UT TWDDDO8TT	TWDDDO16UK TWDDDO16TK	TWDDDO32UK TWDDDO32TK
Output type	TWDDDO8UT, TWDDDO16UK and TWDDDO32UK are transistor sink outputs TWDDDO8TT, TWDDDO16TK and TWDDDO32TK are transistor source outputs		
Connector insertion/removal durability	100 times minimum		
Internal current draw - all outputs on	10 mA (5 VDC) 20 mA (24 VDC)	10 mA (5 VDC) 40mA (24 VDC)	20 mA (5 VDC) 70 mA (24 VDC)
Internal current draw - all outputs off	5 mA (5 VDC) 0 mA (24 VDC)	5 mA (5VDC) 0 mA (24VDC)	10 mA (5 VDC) 0 mA (24 VDC)

### Transistor Source Output Contact

The transistor source output contact is shown below.

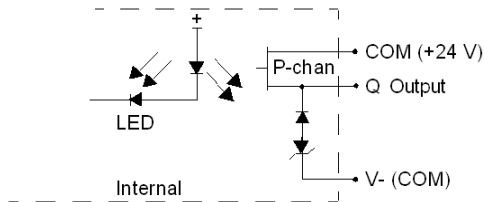

### Transistor Sink Output Contact

The transistor sink output contact is shown below.

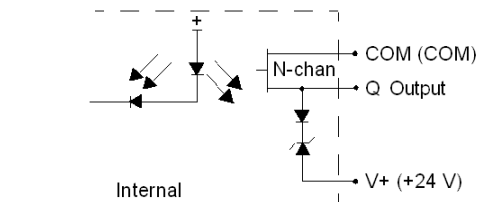

## Output Specifications for the TWD Transistor Output Modules

### Introduction

This section presents the output specifications for the TWD transistor output modules.

### TWDDDO8UT, TWDDDO16UK, TWDDDO32UK, TWDDDO8TT, TWDDDO16TK, and TWDDDO32TK Output Specifications

 **DANGER**

**FIRE HAZARDS**

Possible current overload; size wire accordingly.

**Failure to follow these instructions will result in death or serious injury.**

Reference number	TWDDDO8UT TWDDDO8TT	TWDDDO16UK TWDDDO16TK	TWDDDO32UK TWDDDO32TK
Output type	TWDDDO8UT, TWDDDO16UK and TWDDDO32UK are transistor sink outputs TWDDDO8TT, TWDDDO16TK and TWDDDO32TK are transistor source outputs		
Output points per common Line	8 points in 1 common line	16 points in 1 common line	32 points in 2 common lines
Rated load voltage	24 VDC		
Operating load voltage range	from 20.4 to 28.8 VDC		
Rated load current	0.3 A per output	0.1 A per output	
Maximum load current	0.36 A per output at maximum load (0.3 A at nominal load) 3 A per common line	0.12 A per output at maximum load (0.1 A at nominal load) 1 A per common line	
Voltage drop (on voltage)	1 V maximum (voltage between COM and output terminals when output is on)		
Inrush current	1 A maximum		
Leakage current	0.1 mA maximum		
Clamping voltage	39 V +/- 1 V		
Maximum lamp load	8 W		
Inductive load	L/R = 10 ms (28.8 VDC, 1 Hz)		
External current draw	100 mA maximum, 24 VDC (power voltage at the +V terminal)		





Reference number	TWDDDO8UT TWDDDO8TT	TWDDDO16UK TWDDDO16TK	TWDDDO32UK TWDDDO32TK
Isolation	Between output terminal and internal circuit: photocoupler isolated (isolation protection up to 500 VAC) Between output terminals: not isolated		
Output delay	Turn on time: 300 $\mu$ s maximum Turn off time: 300 $\mu$ s maximum		

## TWD Transistor Output Module Wiring Diagrams

### Introduction

This section shows examples of wiring diagrams for the TWD transistor output modules. Symbols used in the following diagrams are explained in the Glossary of Symbols (*see page 93*) in the appendix.

 <b>DANGER</b>
<b>HAZARD OF ELECTRIC SHOCK, EXPLOSION OR ARC FLASH</b>
<ul style="list-style-type: none"><li>● Disconnect all power from all equipment including connected devices prior to removing any covers or doors, or installing or removing any accessories, hardware, cables, or wires except under the specific conditions specified in the appropriate hardware guide for this equipment.</li><li>● Always use a properly rated voltage sensing device to confirm the power is off where and when indicated.</li><li>● Replace and secure all covers, accessories, hardware, cables, and wires and confirm that a proper ground connection exists before applying power to the unit.</li><li>● Use only the specified voltage when operating this equipment and any associated products.</li></ul>
<b>Failure to follow these instructions will result in death or serious injury.</b>

 <b>WARNING</b>
<b>MALFUNCTION OF OUTPUTS</b>
Use appropriate safety interlocks where personal and/or equipment hazards exist. Outputs can malfunction and remain ON or OFF.
<b>Failure to follow these instructions can result in death, serious injury, or equipment damage.</b>

**NOTE:** These diagrams are for external wiring only.

**NOTE:** The shaded boxes are markings on the discrete I/O modules. The I and Q numbers are the input and output points.

### TWDDDO8UT Wiring Diagram

This diagram is for TWDDDO8UT module.

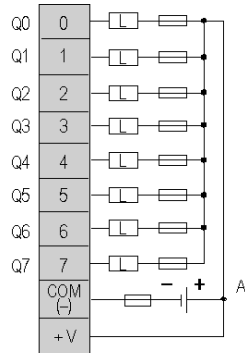

- Connect an appropriate fuse for the load.
- A is the sink wiring (positive logic).

### TWDDDO16UK Wiring Diagram

This diagram is for the TWDDDO16UK module.

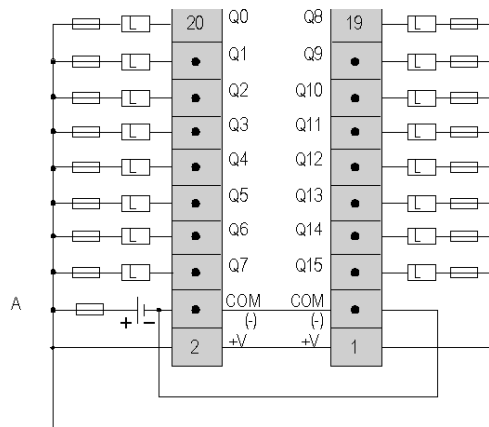

- The COM(-) terminals are connected together internally.
- The +V terminals are connected together internally.
- Connect an appropriate fuse for the load.
- A is the sink wiring (positive logic).

## TWDDDO32UK Wiring Diagram

This diagram is for the TWDDDO32UK module.

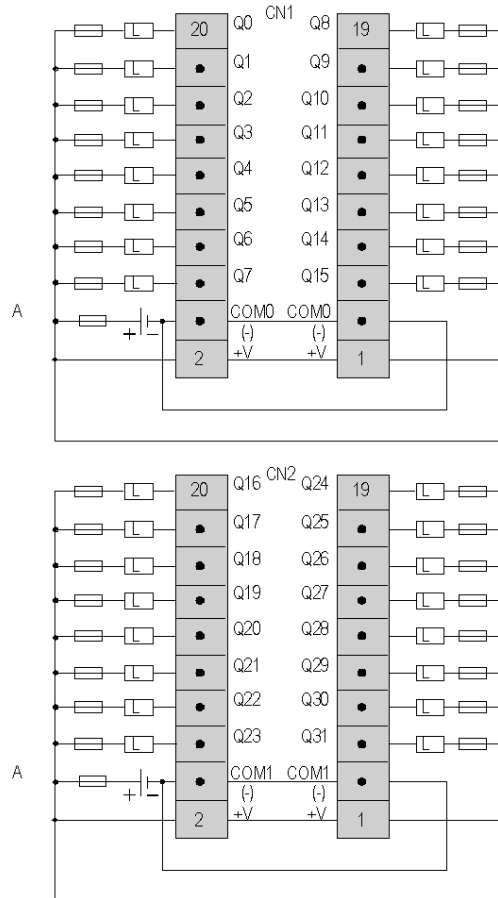

- Terminals on CN1 and CN2 are **not** connected together internally.
- The COM0(-) terminals are connected together internally.
- The COM1(-) terminals are connected together internally.
- The +V terminals are connected together internally.
- Connect an appropriate fuse for the load.
- A is the sink wiring (positive logic).

### TWDDDO8TT Wiring Diagram

This diagram is for the TWDDDO8TT module.

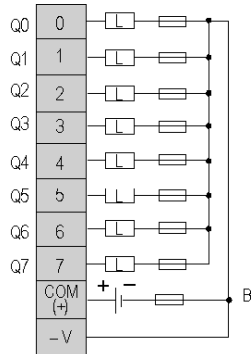

- Connect an appropriate fuse for the load.
- B is the source wiring (negative logic).

### TWDDDO16TK Wiring Diagram

This diagram is for the TWDDDO16TK module.

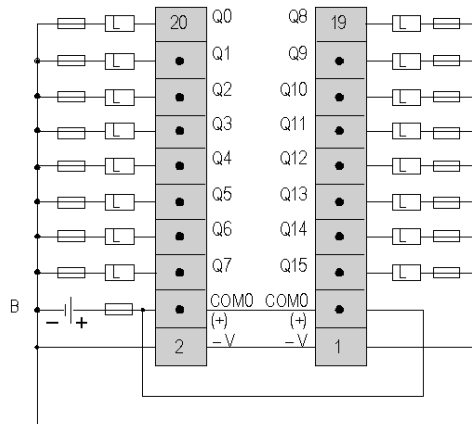

- The COM(+) terminals are connected together internally.
- The -V terminals are connected together internally.
- Connect an appropriate fuse for the load.
- B is the source wiring (negative logic).

## TWDDDO32TK Wiring Diagram

This diagram is for the TWDDDO32TK module.

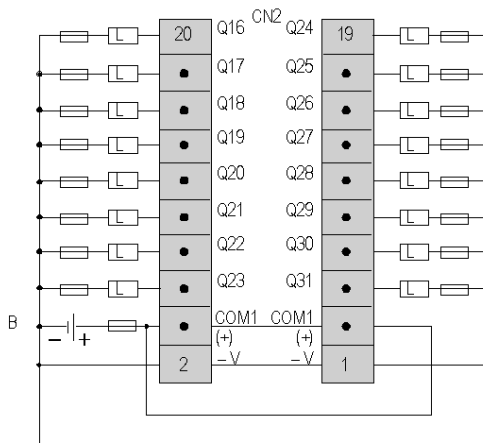
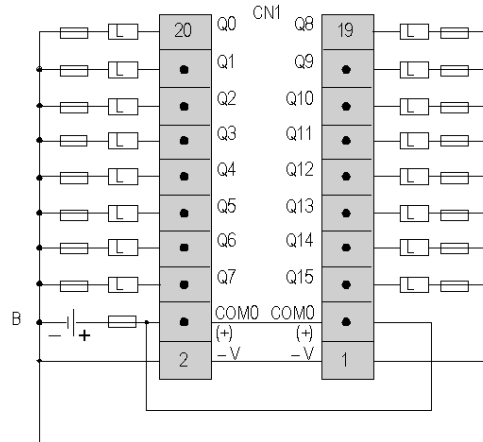

- Terminals CN1 and CN2 are **not** connected together internally.
- The COM0(+) terminals are connected together internally.
- The COM1(+) terminals are connected together internally.
- The -V terminals are connected together internally.
- Connect an appropriate fuse for the load.
- B is the source wiring (negative logic).

---

## 3.6 Specifications and Wiring Diagrams for TWD Discrete Mixed I/O Modules

---

### Introduction

This section provides general, electrical, I/O, and functional specifications, for TWD Discrete Mixed I/O modules.

### What's in this Section?

This section contains the following topics:

Topic	Page
General Specifications for the TWD Mixed I/O Modules	80
Electrical Specifications for the TWD Mixed I/O Modules	81
I/O Specifications for the TWD Mixed I/O Modules	82
TWD Mixed I/O Module Wiring Diagrams	85

## General Specifications for the TWD Mixed I/O Modules

### Introduction

This section presents the general specifications for the TWD mixed I/O modules.

### TWDDMM8DRT and TWDDMM24DRF Input Specifications

#### **WARNING**

##### **UNINTENDED EQUIPMENT OPERATION**

Do not exceed any of the rated values specified below.

**Failure to follow these instructions can result in death, serious injury, or equipment damage.**

Reference number	TWDDMM8DRT	TWDDMM24DRF
I/O points	4 inputs and 4 outputs	16 inputs and 8 outputs
Ambient operating temperature	0°C to 55°C (32°F to 131°F)	
Storage temperature	- 25°C to +70°C (-13°F to +158°F)	
Relative humidity	30 to 95% (non-condensing)	
Degree of pollution	2 (IEC60664)	
Degree of protection	IP 20	
Corrosion immunity	Free from corrosive gases	
Altitude	Operation: 0 to 2,000 m (0 to 6,560 ft) Transport: 0 to 3,000 m (0 to 9,840 ft)	
Resistance to vibration	When mounted on a DIN rail: 10 to 57 Hz, amplitude 0.075 mm, 57 to 150 Hz, acceleration 9.8 m/s <sup>2</sup> (1G) When mounted on a panel surface: 2 to 25 Hz, amplitude 1.6 mm, 25 to 100 Hz, acceleration 39.2 m/s <sup>2</sup> (4G)	
Impact strength	147 m/s <sup>2</sup> (15G) for 11ms duration	
Weight	95 g (3.3 oz)	140 g (4.9 oz)



## Electrical Specifications for the TWD Mixed I/O Modules

### Introduction

This section presents the electrical specifications for the TWD mixed I/O modules.

### TWDDMM8DRT and TWDDMM24DRF Input Specifications

#### **WARNING**

##### **UNINTENDED EQUIPMENT OPERATION**

Do not exceed any of the rated values specified below.

**Failure to follow these instructions can result in death, serious injury, or equipment damage.**

Reference number	TWDDMM8DRT	TWDDMM24DRF
Connector insertion/removal durability	100 times minimum	Not removable
Internal current draw - all I/O on	25 mA (5 VDC) 20 mA (24 VDC)	65 mA (5 VDC) 45 mA (24 VDC)
Internal current draw - all I/O off	5 mA (5 VDC) 0 mA (24 VDC)	10 mA (5 VDC) 0 mA (24 VDC)

## I/O Specifications for the TWD Mixed I/O Modules

### Introduction

This section presents the I/O specifications for the TWD mixed I/O modules.

### TWDDMM8DRT and TWDDMM24DRF Input Specifications

#### WARNING

##### UNINTENDED EQUIPMENT OPERATION

Do not exceed any of the rated values specified below.

**Failure to follow these instructions can result in death, serious injury, or equipment damage.**

Reference number	TWDDMM8DRT	TWDDMM24DRF
I/O points	4 inputs and 4 outputs	16 inputs and 8 outputs
Rated input voltage	24 VDC source/sink input signal	
Input voltage range	from 20.4 to 28.8 VDC	
Rated input current	7 mA/input (24 VDC)	
Input impedance	3.4 k $\Omega$	
Turn on time (24 VDC)	4 ms (24 VDC)	
Turn off time (24 VDC)	4 ms (24 VDC)	
Isolation	Between input terminals and internal circuit: photocoupler isolated (isolation protection up to 500 VAC) Between input terminals: not isolated	
External load for I/O interconnection	Not needed	
Signal determination method	Static	
Input signals type	Both sinking and sourcing input signals can be connected.	
Cable length	3m (9.84 ft.)	

### TWDDMM8DRT and TWDDMM24DRF Input Operating Range

The input operating range of the Type 1 (IEC 61131-2) input module is shown below.

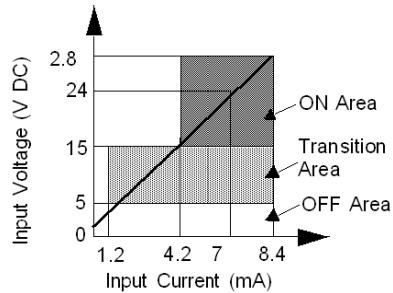

### TWDDMM8DRT and TWDDMM24DRF Input Internal Circuit

The input internal circuit is shown below.

Standard Sink or Source Input

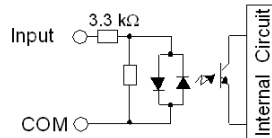

### TWDDMM8DRT and TWDDMM24DRF Usage Limits

When using TWDDMM24DRF at an ambient temperature of 55°C (131°F) in the normal mounting direction, limit the inputs and outputs, respectively, which turn on simultaneously along line (1). At 45°C (113°F), all inputs and outputs can be turned on simultaneously at 28.8 VDC as indicated with line (2).

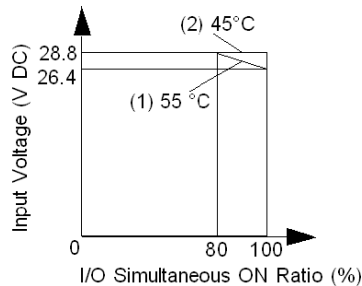

When using TWDDMM8DRT, all inputs and outputs can be turned on simultaneously at 55°C (131°F), input voltage 28.8 VDC.

### TWDDMM8DRT and TWDDMM24DRF Output Specifications

Reference number	TWDDMM8DRT	TWDDMM24DRF
Output points and common lines	4 NO contacts in 1 common line	8 NO contacts in 2 common lines
Maximum load current	2 A per output 7 A per common line	
Minimum switching load	0.1 mA/0.1 VDC (reference value)	
Initial contact resistance	30 mΩ maximum	
Electrical life	100,000 operations minimum (rated resistive load 1,800 operations/h)	
Mechanical life	20,000,000 operations minimum (no load 18,000 operations/h)	
Rated load (resistive/inductive)	240 VAC/2 A, 30 VDC/2 A	
Dielectric strength	Between the output and ground terminals: 1500 VAC, 1 minute Between output terminal and internal circuit: 1500 VAC, 1 minute Between output groups: 1500 VAC, 1 minute	

### TWDDMM8DRT and TWDDMM24DR Output Delay

The output delay is shown below.

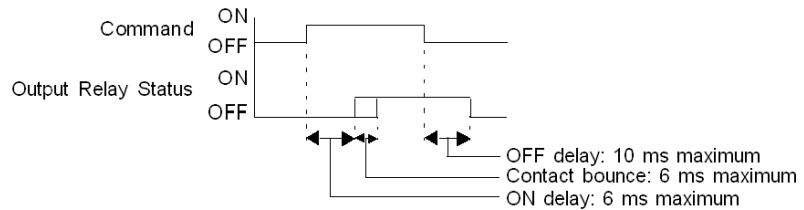

## TWD Mixed I/O Module Wiring Diagrams

### Introduction

This section shows examples of wiring diagrams for the TWD mixed I/O modules. Symbols used in the following diagrams are explained in the Glossary of Symbols (*see page 93*) in the appendix.

### DANGER

#### HAZARD OF ELECTRIC SHOCK, EXPLOSION OR ARC FLASH

- Disconnect all power from all equipment including connected devices prior to removing any covers or doors, or installing or removing any accessories, hardware, cables, or wires except under the specific conditions specified in the appropriate hardware guide for this equipment.
- Always use a properly rated voltage sensing device to confirm the power is off where and when indicated.
- Replace and secure all covers, accessories, hardware, cables, and wires and confirm that a proper ground connection exists before applying power to the unit.
- Use only the specified voltage when operating this equipment and any associated products.

**Failure to follow these instructions will result in death or serious injury.**

### WARNING

#### MALFUNCTION OF OUTPUTS

Use appropriate safety interlocks where personal and/or equipment hazards exist. Outputs can malfunction and remain ON or OFF.

**Failure to follow these instructions can result in death, serious injury, or equipment damage.**

**NOTE:** These diagrams are for external wiring only.

**NOTE:** The shaded boxes are markings on the discrete I/O modules. The I and Q numbers are the input and output points.

### TWDDMM8DRT Wiring Diagram

This diagram is for the TWDDMM8DRT module.

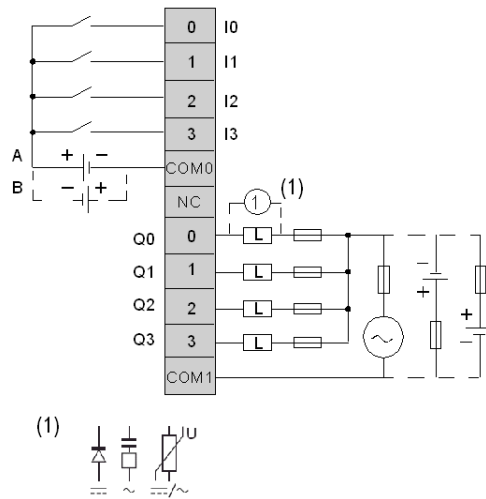

- The COM0 and COM1 terminals are **not** connected together internally.
- Both sink and source input wiring are supported
- A is the sink wiring (positive logic).
- B is the source wiring (negative logic).
- (1) is the protection for inductive load.

## TWDDMM24DRF Wiring Diagram

This diagram is for the TWDDMM24DRF module.

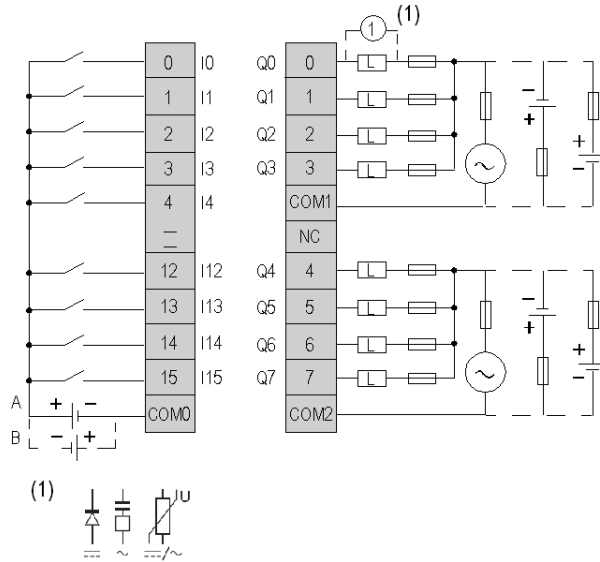

- The COM0, COM1 and COM2 terminals are **not** connected together internally.
- Connect an appropriate fuse for the load.
- Both sink and source input wiring are supported
- A is the sink wiring (positive logic).
- B is the source wiring (negative logic).
- (1) is the protection for inductive load.





---

# Appendices



---

## Introduction

This appendix provides information on system diagnostic using LED's, operator display operation, troubleshooting, the DIN rail, common IEC symbols used in this manual, and agency compliance.

## What's in this Appendix?

The appendix contains the following chapters:

Chapter	Chapter Name	Page
A	The DIN Rail	91
B	IEC Symbols	93
C	Agency Compliance	95



---

## The DIN Rail

A

---

### The DIN Rail

#### Introduction

You can mount the Twido controller and its expansions on a DIN rail. A DIN rail can be attached to a smooth mounting surface or suspended from a EIA rack or in a NEMA cabinet.

#### Dimensions of the DIN Rail

The DIN rail measures 35 mm (*1.38 in.*) high and 15 mm (*0.59 in.*) deep, as shown below.

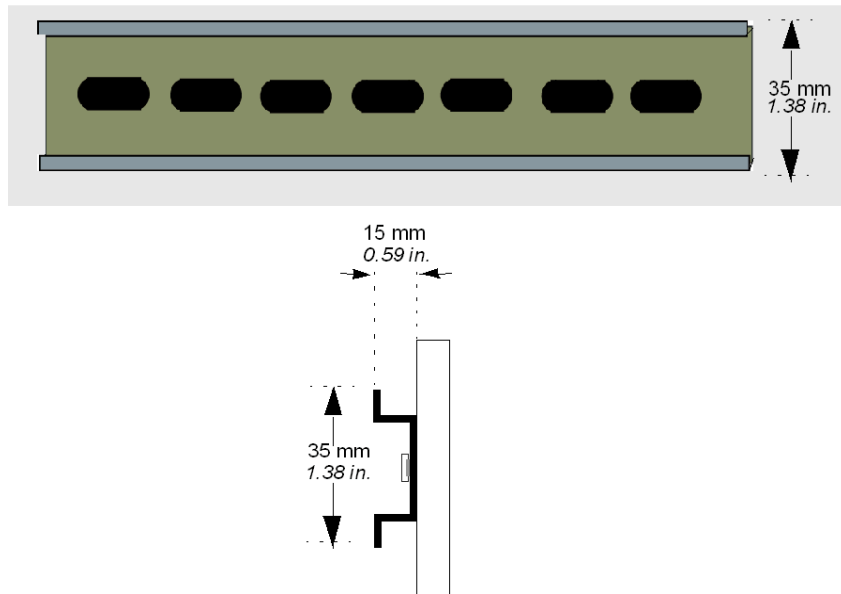

### Recommended Equipment

You can order the suitable DIN rail from Schneider Electric:

<b>Rail depth</b>	<b>Catalogue part number</b>
15 mm ( <i>0.59 in.</i> )	AM1DE200

---

# IEC Symbols



---





## Glossary of Symbols



### Introduction

This section contains illustrations and definitions of common IEC symbols used in describing wiring schematics.

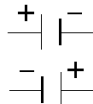
### Symbols

Common IEC symbols are illustrated and defined in the table below:

	Fuse
	Load
	AC power
	DC power
	Discrete sensor/input, for example, contact, switch, initiator, light barrier, and so on.
	Ground

	2-wire sensor
	Thermocouple element

---

# Agency Compliance



---

## Agency Requirements

### Introduction

This section provides agency standards for the Twido products.

### Standards

Twido controllers comply with the main national and international standards concerning electronic industrial control devices.

The following are specific controller requirements:

- EN 61131-2 (IEC 61131-2)
- UL 508
- UL 1604 / CSA 213 Class I Division 2 Groups A, B, C, D





---

# Glossary

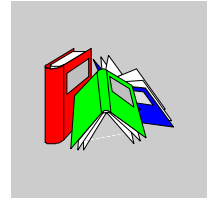

---

## A

### Analog potentiometer

It can be used to preset a value for an analog timer. All Modular controllers and Compact 10 and 16 I/O controllers have one analog potentiometer. The Compact 24 I/O controller has two:

### Analog Voltage Input Connector

Connects an analog voltage source of 0 through 10 VDC. The analog voltage is converted to a discrete value and is stored in a system word.

## C

### CAN

**Controller Area Network:** field bus originally developed for automobile applications which is now used in many sectors, from industrial to tertiary.

### Cartridge Connector

A connector to attach an optional memory cartridge or an RTC.

### Catch Input

Verify that you are receiving short input pulses (rising pulse of 40  $\mu$ s or falling pulse of 150  $\mu$ s minimum) from sensors without regard to the scan time.

**CiA**

**CAN in Automation:** international organization of users and manufacturers of CAN products.

**COB**

**Communication Object:** transport unit on CAN bus. A COB is identified by a unique identifier, which is coded on 11 bits, [0, 2047]. A COB contains a maximum of 8 data bytes. The priority of a COB transmission is shown by its identifier - the weaker the identifier, the more priority the associated COB has.

**Communication Adapter**

An optional cartridge that can be attached to any Compact controller or Operator Display Expansion Module to provide an optional Serial Port 2.

**Communication Expansion Module**

An optional module that can be attached to any Modular controllers communications expansion bus to provide an optional Serial Port 2.

**Controller status output**

A special function. This function is used in circuits, external to the controller, to control the power supply to the output devices or the controller power supply.

**E**

**EDS**

**Electronic Data Sheet:** description file for each CAN device (provided by the manufacturers).

**ERR LED**

An LED that illuminates when a detected error is detected in the controller.

**Expansion connector**

A connector to attach expansion I/O modules.

**Expansion Connector Cover**

A cover to protect the expansion connector.

**Expansion I/O Module**

Either a discrete or analog module that adds additional I/O to the base controller.

**F****Fast Counting**

A special function, it is available as a single up counter and single down counter. These functions enable up counting or down counting of pulses (rising edges) on a discrete I/O. Compact controllers can be equipped with three fast counters. Modular controllers can have two fast counters.

**Free Wire**

The end of a discrete I/O cable whose wires do not have a connector. This scheme provides connectivity from Modular I/O to discrete I/O points.

**I****I/O**

Input/Output.

**I/O terminals**

Terminals on all Modular controllers and expansion I/O modules used to connect input and output signals. The input terminals accept both sink and source DC input signals. The output terminals are either transistor source or sink or relay contacts.

**IN LED**

An LED that illuminates when a corresponding input is on. All modules have IN LEDs.

**Input Filter**

A special function that rejects input noises. This function is useful for addressing input noises and chatter in limit switches. All inputs provide a level of input filtering using the hardware. Additional filtering using the software is also configurable through TwidoSuite.

**Input Simulators**

An optional accessory for Compact controllers that is used for debugging. It can simulate input sensors to test application logic.

**Input terminals**

Terminals on the top of all Compact controllers used to connect input signals from input devices such as sensors, push buttons, and limit switches. The input terminals accept both sink and source DC input signals.

**L**

**Latching input**

A special function. This function is used to memorize any pulse with a duration less than the controller scan time. When a pulse is shorter than one scan and has a value greater than or equal to 100  $\mu$ s, the controller latches the pulse, which is then updated in the next scan.

**M**

**Memory Cartridge**

An optional cartridge available in two sizes: 32 KB and 64 KB (64 KB not available on Compact). It can be added to any controller for removable backup of applications or to load an application, if certain conditions exist. The 64 KB cartridge is also used to increase program memory.

**Modbus Master Mode**

Allows the controller to initiate a Modbus query transmission, with a response expected from a Modbus slave.

**Modbus Slave Mode**

Allows the controller to respond to Modbus queries from a Modbus master and is the default communications mode if no communication is configured.

## O

### **Operator display expansion module**

An optional module that can be attached to any Modular controller to display program information.

### **Operator display module**

An optional module that can be attached to any Compact controller to display program information.

### **OUT LED**

An LED that illuminates when a corresponding output is on. All modules have OUT LEDs.

### **Output terminals**

Terminals on the bottom of all Compact controllers used to connect output signals from output devices such as electromechanical relays and solenoid valves. The internal output relay contact is rated up to 240 VAC/2A or 30 VDC/2A.

## P

### **PLS**

A special function. This user-defined function block generates a signal on output %Q0.0.0 or %Q0.0.1. This signal has a variable period but has a constant duty cycle, or on to off ratio of 50% of the period.

### **Power Supply Terminals**

The power supply is connected to these terminals to provide power to the controller. The power voltage for a Compact controller is 100-240 VAC and 24 VDC for a Modular controller.

### **PWM**

A special function. This user-defined function block generates a signal on output %Q0.0.0 or %Q0.0.1. This signal has a constant period with the possibility of varying the duty cycle, or on to off ratio.

**PWR LED**

An LED that illuminates when power is supplied to the controller.

**R**

**Removable Cover**

A cover on all Compact controllers that can be removed to install an optional Operator Display.

**RTC**

Real Time Clock.

**RTD**

Temperature detector of type PT100, PT1000 etc. Resistor Temperature Detector.

**RUN LED**

An LED that illuminates when the controller is executing a program.

**S**

**Sensor power terminals**

Supplies power to the sensors (24 VDC, 400 mA for -40DRF compact controllers and 250 mA for all other controllers). Output terminals are only intended for input devices and not be used as a source for driving external loads.

**Serial Port 1**

An EIA RS-485 connector used to download and monitor the controller operation using TwidoSuite.

**Serial port 2**

An optional port that can be configured as either EIA RS-232 or EIA RS-485.

**STAT LED**

An LED that blinks on and off to indicate a specific status of the user program.

**T****Terminal cover**

A cover on all Compact controllers to protect the input and output terminals.

**V****Very Fast Counting**

A special function available as an up/down counter, an up/down 2-phase counter, a single up counter, a single down counter, and frequency meter. The counter functions enable counting of pulses from 0 to 65,535 in single-word mode and from 0 to 4,294,967,295 in double-word mode. The frequency meter function measures the frequency of a periodic signal in Hz.





---

# Index

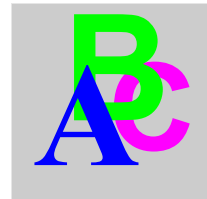

---

## A

Agency requirements, *95*

## B

### Bases

Assembling an expansion I/O module, *23*

Disassembling an expansion I/O module,  
*25*

Minimum clearance, *26*

Mounting positions, *21*

## C

Cables, *13*

### Compact

Minimum clearance, *26*

## D

### Dimensions

Discrete I/O modules, *29, 30, 30, 31, 31*

### DIN rail

15 mm AM1DE200 rail, *92*

### Discrete I/O

Input internal circuit, *46*

Operating range, *45*

Discrete I/O cables, *13*

### Discrete I/O modules

Dimensions, *29, 30, 30, 31, 31*

### Discrete I/O Modules

Features, *14*

### Discrete I/O modules

Installing on a DIN rail, *34*

Mounting hole layout, *33*

Overview, *39*

Parts description, *42*

Removing from a DIN rail, *35*

Specifications, *12*

Transistor sink output contact, *71*

Transistor source output contact, *71*

### Discrete Input modules

I/O usage limits, *54*

Operating range, *61*

Wiring diagrams, *55*

### Discrete Input modules

Internal circuit, *53*

## E

### Expansion I/O modules

Assembling to a base, *23*

Disassembling from a base, *25*

## I

### I/O modules

Discrete, *12*

Expansion modules, *12*

### I/O usage limits

Discrete I/O modules, *83*

Discrete Input modules, *54*

### IEC symbols, *93*

### Input I/O modules, *14*

Input internal circuit

- Discrete I/O modules, 83
- Discrete I/O Modules, 46

Installation

- Read before starting, 19

Installation preparation, 20

Installing on a DIN rail, 34

Internal circuit

- Discrete Input modules, 53

## M

Main Features, 14

Minimum clearance

- Bases, 26
- Compact, 26
- Modular, 27

Mixed I/O modules, 14

- I/O usage limits, 83
- Input internal circuit, 83
- Operating range, 83
- Output delay, 84
- Wiring diagrams, 85

Modular

- Minimum clearance, 27

Mounting hole layout

- Discrete I/O modules, 33

## O

Operating range

- Discrete I/O modules, 83
- Discrete I/O Modules, 45
- Discrete Input modules, 61

Output delay

- Discrete I/O modules, 84
- Relay Output modules, 65

Output I/O modules, 14

Overview

- Discrete I/O module, 39

## P

Parts description

- Discrete I/O modules, 42

## R

Read before starting, 20

Relay output contact

- Relay Output modules, 64

Relay Output modules

- Relay output contact, 64
- Wiring diagrams, 66

Relay utputO modules

- Output delay, 65

## S

Specifications

- Discrete I/O modules, 12

Standards, 95

Starting, 19, 20

Symbols, 93

## T

Transistor Output modules

- Wiring diagrams, 74

Transistor sink output contact

- Discrete I/O modules, 71

Transistor source output contact

- Discrete I/O modules, 71

## W

Wiring diagrams

- Discrete I/O modules, 74, 85
- Discrete Input modules, 55
- Relay Output modules, 66