



GE Fanuc Automation

PowerMotion® Products

Servo Product Specification Guide

GFH - 001B

September 1998

Notice

This document is based on information available at the time of its publication. While efforts have been made to be accurate, the information contained herein does not purport to cover all details or variations in hardware or software, nor to provide or every possible contingency in connection with installation, operation, or maintenance. Features may be described herein which are not present in all hardware and software systems. GE Fanuc Automation assumes no obligation of notice to holders of this document with respect to changes subsequently made.

GE Fanuc Automation makes no representation or warranty, expressed, implied, or statutory with respect to, and assumes no responsibility for the accuracy, completeness, sufficiency, or usefulness of the information contained herein. No warranties of merchantability or fitness for purpose shall apply.

CONTENTS

Part I: α Series Servo System

SECTION 1: α SVU Series Servo System Block Diagram	5
SECTION 2: α Series Servo Product Overview	6
2.1 α Series Motors.....	6
2.2 α Series Motor Speed-Torque Curves.....	7
2.3 α Series Motor Holding Brake.....	8
2.4 α SVU Series Servo Amplifiers	9
SECTION 3: α Series Servo System Specifications	10
SECTION 4: α Servo System Options	11
4.1 IP67 Sealing Option on α Series Servo Motors.....	12
4.2 Absolute Encoder Battery Packs.....	13
SECTION 5: Installation Guidelines	14
5.1 Motor Environmental Requirements	14
5.2 α Servo Amplifier Environmental Requirements.....	14
5.3 α SVU Series servo amplifier heat Dissipation	15
5.4 α Series Motor Dimensions	16
5.4.1 $\alpha 6/3000$	16
5.4.2 $\alpha 6/3000$ with brake, side view	17
5.4.3 $\alpha 12/3000$, $\alpha 22/2000$, and $\alpha 30/3000$, front view	18
5.4.4 $\alpha 12/3000$, $\alpha 22/2000$, and $\alpha 30/3000$, side view	19
5.4.5 $\alpha 12/3000$, $\alpha 22/2000$, and $\alpha 30/3000$ with brake, side view	20
5.4.6 $\alpha 40/2000$ with fan, front and rear views.....	21
5.4.7 $\alpha 40/2000$ with fan, top and side views.....	22
5.4.8 $\alpha 40/2000$ with fan and brake, top and side views	23
5.5 Shaft Loading.....	24
5.6 α SVU1 Series Amplifier and Panel Cutout Dimensions	25
5.6.1 α SVU1-80 and SVU1-130 dimension drawings	25
5.6.2 α SVU1-80 and SVU1-130 panel cutout drawings	27
5.7 α SVU Series Switch Settings	28
5.8 Noise Protection.....	29
5.8.1 Separation of Signal and Power Lines.....	29
5.8.2 Grounding.....	29
5.9 Command Cable Grounding.....	30
5.10 Selecting a ground fault interrupter.....	31
SECTION 6: Servo System Power Requirements	32
6.1 Power Line Protection	32
6.2 AC Line Filter	32
6.3 Circuit Breaker Selection.....	34
6.4 Electromagnetic Contactor (MCC) Rating.....	34
6.5 Incoming AC power	35
6.5.1 AC Power Ratings.....	35
6.6 Discharging Regenerative Energy	36
6.6.1 Calculating the Average Regenerative Energy.....	36
6.6.2 Regenerative discharge unit dimensions	40
6.6.3 Regenerative discharge unit panel cutout dimensions.....	42

SECTION 7: α Servo System Connection	43
7.1 α SVU1 Amplifier Connections	43
7.2 α System Connections	44
7.3 α Servo Connection Diagram	46
7.4 Connection Details	47
SECTION 8: α SVU Series Protection and Alarm Functions	59
Part II: β Series Servo System	
SECTION 9: β Servo System Block Diagram	63
SECTION 10: β Series Servo Product Overview	64
10.1 β Series Motors	64
10.2 β Series Motor Speed-Torque Curves.....	65
10.3 β Series Motor Holding Brake.....	66
10.4 β Series Servo Amplifiers.....	67
SECTION 11: β Series Servo System Specifications	68
SECTION 12: β Servo System Options	69
12.1 Absolute Encoder Battery Packs.....	70
SECTION 13: Installation Guidelines	71
13.1 Motor Environmental Requirements	71
13.2 β Servo Amplifier Environmental Requirements	71
13.3 β Servo Amplifier Heat Dissipation and Maintenance Clearances.....	72
13.4 β Series Motor Dimensions.....	73
13.4.1 β 0.5/3000 Motor, front and side views.....	73
13.4.2 β 2/3000, β 6/2000, and α C12/2000 motors, front view	74
13.4.3 β 2/3000, β 6/2000, and α C12/2000 motors, side view.....	75
13.4.4 β 2/3000, β 6/2000, and α C12/2000 motors with brake.....	76
13.5 Shaft Loading	77
13.6 β Series Amplifiers DIMENSIONS	78
13.7 Noise Protection	79
13.7.1 Separation of Signal and Power Lines	79
13.7.2 Grounding.....	79
13.8 Command Cable Grounding	80
13.9 Selecting a Ground Fault Interrupter.....	81
SECTION 14: β Servo System Power Requirements	82
14.1 Power Line Protection	82
14.2 AC Line Filter	82
14.3 Circuit Breaker Selection.....	83
14.4 Electromagnetic Contactor Rating	83
14.5 Incoming AC power	84
14.5.1 AC Power Ratings.....	84
14.6 Incoming DC Power.....	85
14.7 Discharging Regenerative Energy	85
14.7.1 Calculating the Average Regenerative Energy.....	86
SECTION 15: β Servo System Connection	88
15.1 System Connections.....	88
15.2 β Connection Diagram.....	90
15.3 Connection Details	91
15.4 β Series Amplifier Protection and Alarm Functions.....	105



GE Fanuc

PowerMotion® *α and β Series Servo*

RELIABILITY

The α and β Series Servo systems offer high reliability and performance. In addition, high speed serial encoders and high efficiency Integrated Power Modules further enhance the performance of the servo systems.

The servo systems' digital control loops (current, velocity, and position) are closed in the controller. This feature reduces setup time and delivers significant performance gains even in the most challenging applications.

FEATURES

Additional features of the servo systems include the following:

- The systems' plug-and-play connectivity makes them cost-effective to integrate and maintain.
- The all-digital systems provide the greatest possible stability in a changing environment.
- There are no "personality" modules.
- The servos have a broad application range including a wide load inertia range, flexible acceleration/deceleration, and position feedback configurations.
- Extensive software customization features are available to optimize performance and overcome machine limitations.

α AND β SERVO MOTORS

The α and β Series Servo motors offer superior performance with reduced size and cost.

The β Series motors feature a new insulation system on the windings and an overall sealing coating help protect the motor from the environment.

The α and β Series motors conform to international IEC standards. A motor protection level of IP65 is standard with all α and β Series motors, and optional IP67 sealing is available on α Series motors. Torque ratings of 0.5, 2, 6, and 12 Nm are available on β Series motors, and torque ratings of 6, 12, 22, 30, and 40 Nm are available on α Series motors.

A 32K counts /revolution absolute mode digital encoder is standard with each β Series servo motor. A 64K absolute encoder is standard on α Series motors. An optional electrically released holding brake is also available on all α and β Series motors.

α AND β AMPLIFIERS

The α and β Series Servo amplifiers integrate a power supply with the PWM switching circuitry, making the amplifier compact and very efficient. The amplifier is built to conform to these international standards:

- European CE (EMC and Low Voltage directives)
- IEC Standards
- UL/CUL on α Series

PULSE WIDTH MODULATED INTERFACE

The Pulse Width Modulated (PWM) interface uses the standard GE Fanuc digital servo communication protocol.

The α and β Series amplifiers can communicate with a wide variety of GE Fanuc controllers, including the Power Mate D, Power Mate H, and DSM 300 Series, plus many of the GE Fanuc CNC systems.

This page intentionally left blank.

Part I:
 α Servo
System

Section 1: α SVU Series Servo System Block Diagram

The following block diagram shows the interconnections of a typical α Series servo system:

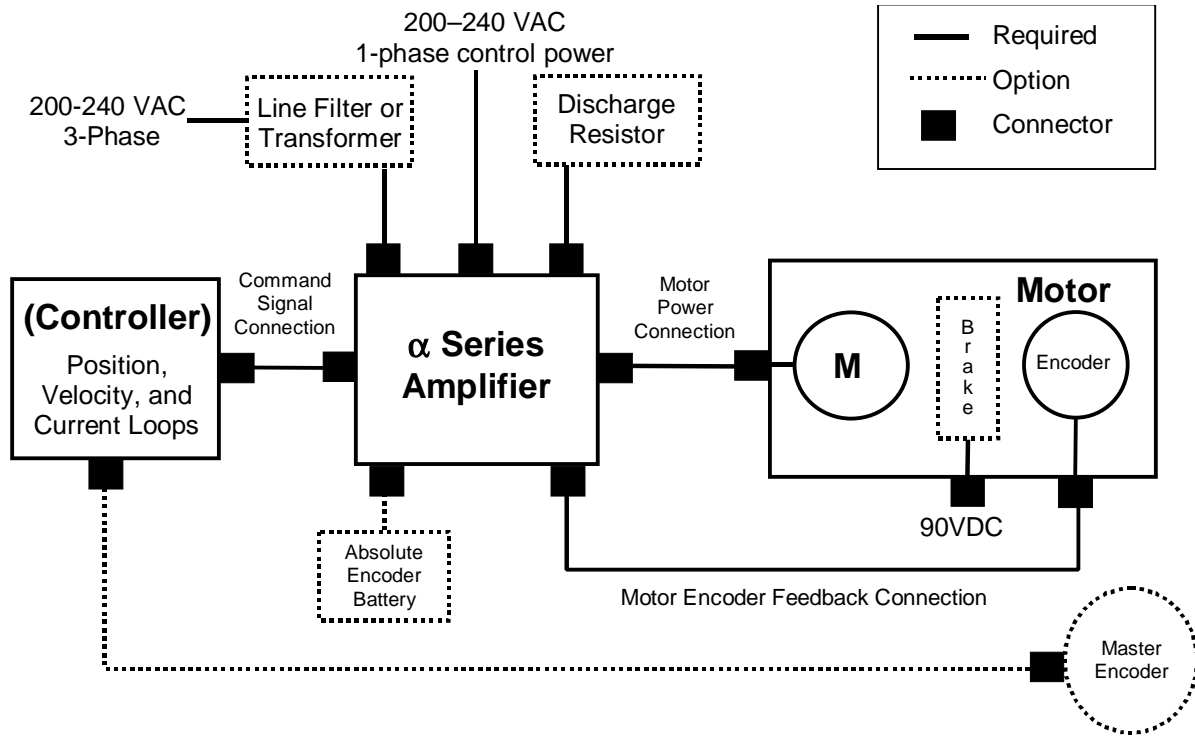

Figure 1. α SVU Series servo block diagram

NOTE

The 200–240 VAC control power inputs are jumpered to the three-phase bus power inputs (L1C to L1 and L2C to L2) when delivered from the factory. If a separate control power source is desired to maintain alarm status during E-stop removal of main bus power, remove the jumper links and connect the separate control power.

Section 2: α Series Servo Product Overview

2.1 α SERIES MOTORS

The α Series servo motors include built-in serial encoders with 64K PPR (pulses per revolution) resolution. All α Series motors are available with an optional holding brake, and most are available with an optional IP67 sealing. A fan package is standard on the α40/2000 servo motor. The servo motors must be used with the designated amplifier package and a GE Fanuc motion controller such as the Motion Mate DSM300 Series.

Table 1 provides a summary of the α Series servos. See Section 3 for more detailed motor specifications.

Table 1. α Series Servo Motors

Motor	Rated Torque	Power Rating	Required Amplifier Kit	Motor Catalog #
α6/3000	6 Nm (53 in-lbs) continuous stall torque; 3000 RPM (max)	1.4 kW	80 Amp (IC800APK080)	Motor Only: A06B-0128-B575#7008 w/ IP67 Sealing: A06B-0128-B575#7076 w/ Brake: A06B-0128-B675#7008 w/ IP67 Sealing & Brake: A06B-0128-B675#7076
α12/3000	12 Nm (106 in-lbs) continuous stall torque; 3000 RPM (max)	2.8 kW	80 Amp (IC800APK080)	Motor Only: A06B-0143-B075#7008 w/ IP67 Sealing: A06B-0143-B075#7076 w/ Brake: A06B-0143-B175#7008 w/ IP67 Sealing & Brake: A06B-0143-B175#7076
α22/2000	22 Nm (195 in-lbs) continuous stall torque; 2000 RPM (max)	3.7 kW	80 Amp (IC800APK080)	Motor Only: A06B-0147-B075#7008 w/ IP67 Sealing: A06B-0147-B075#7076 w/ Brake: A06B-0147-B175#7008 w/ IP67 Sealing & Brake: A06B-0147-B175#7076
α30/3000	30 Nm (265 in-lbs) continuous stall torque; 3000 RPM (max)	5.2 kW	130 Amp (IC800APK130)	Motor Only: A06B-0153-B075#7008 w/ IP67 Sealing: A06B-0153-B075#7076 w/ Brake: A06B-0153-B175#7008 w/ IP67 Sealing & Brake: A06B-0153-B175#7076
α40/2000 w/ fan package	40 Nm (494 in-lbs) continuous stall torque; 2000 RPM (max)	7.2 kW	130 Amp (IC800APK130)	Motor w/ Fan Package: A06B-0158-B075#7008 w/ Fan Package & Brake: A06B-0158-B175#7008

2.2 α SERIES MOTOR –TORQUE CURVES

The curves shown below illustrate the relationship between the speed of the motor and the output torque. The motor can operate continuously at any combination of speed and torque within the prescribed continuous operating zone. The limit of the continuous operating zone is determined with the motor's ambient temperature at 40°C and its drive current as pure sine wave. Actual operation is limited by the current of the servo drive unit.

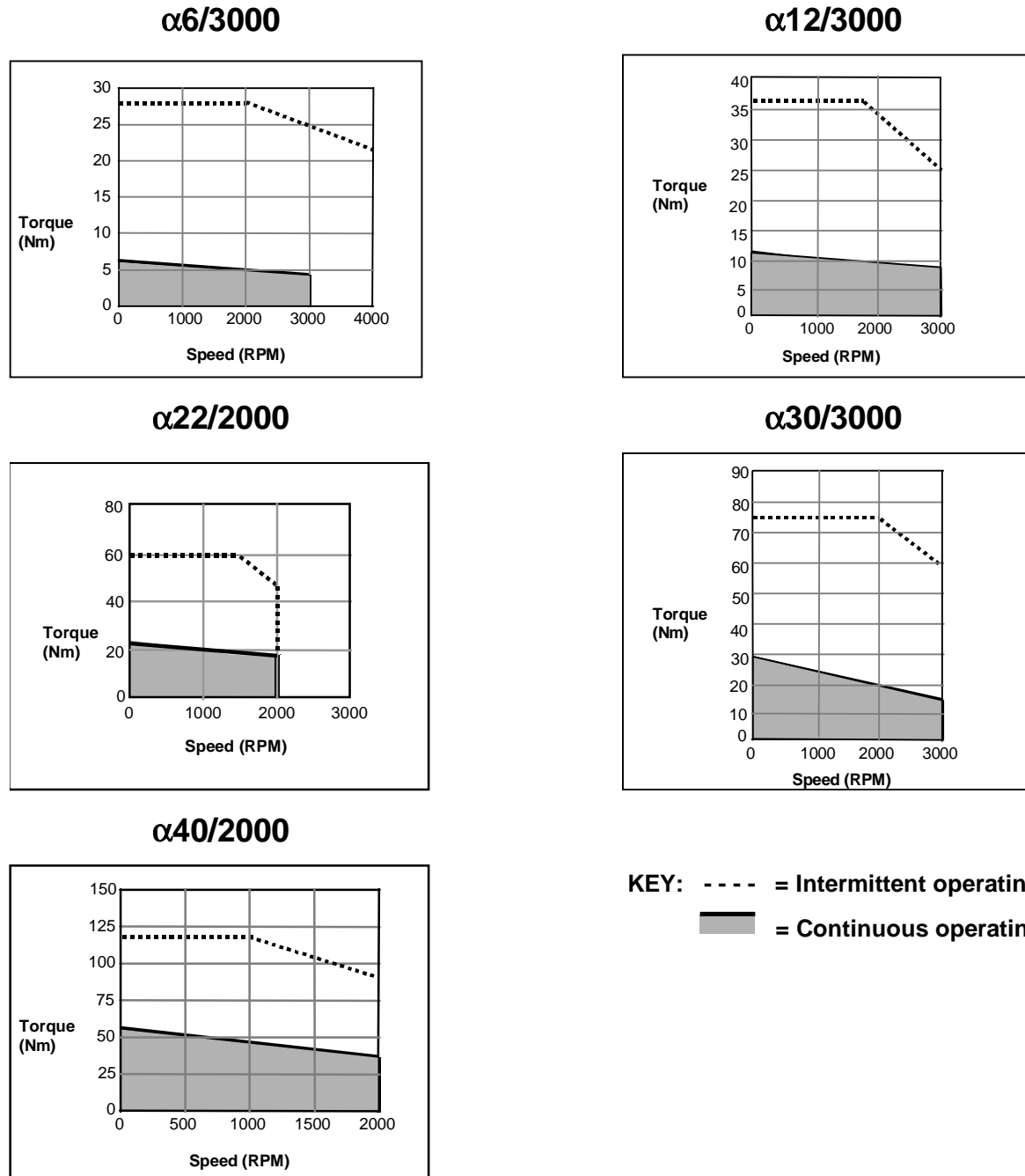

Figure 2. α Series motor speed-torque curves

2.3 α SERIES MOTOR HOLDING BRAKE

Any of the servo motors can be ordered with a holding brake. The brake is used to prevent movement on horizontal axes or falling along the vertical axis when the servo motor control is turned off.

Brakes are spring-set and electrically released and are designed for holding stationary loads only. Using the holding brake to stop a moving axis may damage the motor or severely reduce its service life.

The specifications of the built-in brakes are listed in Table 2:

Table 2. Brake specifications

Parameter	SERVO PACKAGE				
	α 6/3000	α 12/2000	α 22/2000	α 30/3000	α 40/2000
Brake torque	71 in-lb 8 Nm 82 kgf-cm	310 in-lb 35 Nm 357 kgf-cm	310 in-lb 35 Nm 357 kgf-cm	310 in-lb 35 Nm 357 kgf-cm	310 in-lb 35 Nm 357 kgf-cm
Release Response Time	80 msec	150 msec	150 msec	150 msec	150 msec
Brake Response Time	40 msec	20 msec	20 msec	20 msec	20 msec
Supply Voltage and Current	90 VDC ($\pm 10\%$) 0.4 A or less	90 VDC ($\pm 10\%$) 0.6 A or less	90 VDC ($\pm 10\%$) 0.6 A or less	90 VDC ($\pm 10\%$) 0.6 A or less	90 VDC ($\pm 10\%$) 0.6 A or less
Weight Increase	Approx. 5 lb Approx. 2.3 kg	Approx. 13.8 lb Approx. 6.3 kg	Approx. 13.8 lb Approx. 6.3 kg	Approx. 13.8 lb Approx. 6.3 kg	Approx. 22 lb Approx. 10 kg
Inertia Increase	0.00061 in-lb-s ² 0.00007 kg m ² 0.0007 kgf-cm-s ²	0.0052 in-lb-s ² 0.0006 kg m ² 0.006 kgf-cm-s ²	0.0052 in-lb-s ² 0.0006 kg m ² 0.006 kgf-cm-s ²	0.0052 in-lb-s ² 0.0006 kg m ² 0.006 kgf-cm-s ²	0.0087 in-lb-s ² 0.0010 kg m ² 0.010 kgf-cm-s ²

An example of a typical **user-supplied** brake power supply is shown below:

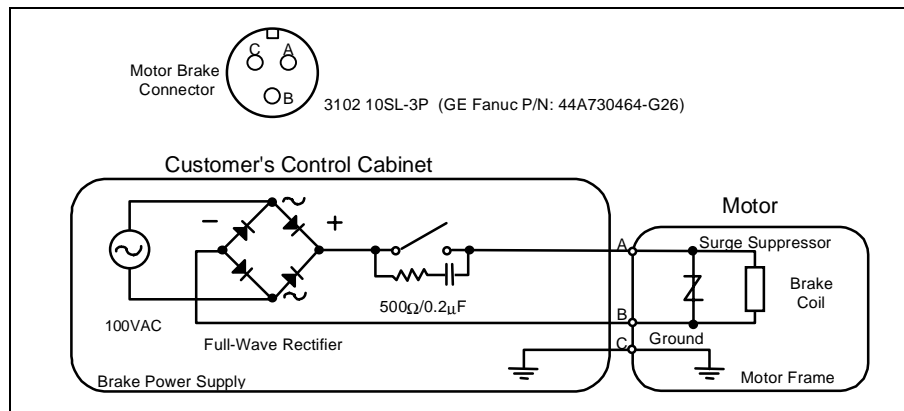

Figure 3. Typical user-supplied brake power supply

2.4 α SVU SERIES SERVO AMPLIFIERS

The α SVU Series amplifiers must be matched to the corresponding α Series motor. Because motor characteristics are closely related to amplifier ratings, GE Fanuc restricts the allowable motor/amplifier combinations to those shown in Table 3 below.

GE Fanuc offers α SVU Series amplifiers either separately, for replacement and spare parts, or as preconfigured packages that include the connectors and spare fuses necessary for most new installations. The catalog numbers for both options and package contents are shown in the following tables.

Table 3. α SVU Series models

Motor	Amplifier Model	Amplifier Catalog #	Amplifier Package Catalog #
α6/3000	SVU1-80	A06B-6089-H105	IC800APK080
α12/3000	SVU1-80	A06B-6089-H105	IC800APK080
α22/2000	SVU1-80	A06B-6089-H105	IC800APK080
α30/3000	SVU1-130	A06B-6089-H106	IC800APK130
α40/2000	SVU1-130	A06B-6089-H106	IC800APK130

Table 4. α SVU Series packages

Description	Package Contents*	Catalog #
80 Amp α Series Amplifier Package	<ul style="list-style-type: none"> • 1 SVU1-80 Amp (A06B-6093-H105) • 1 Fuse (A06B-6089-K250) • 1 External MCC Connector (A06B-6089-K201) • 1 E-Stop Connector (A02B-0120-K321) 	IC800APK080
130 Amp α Series Amplifier Package	<ul style="list-style-type: none"> • 1 SVU1-130 Amp (A06B-6093-H106) • 1 External MCC Connector (A06B-6089-K201) • 1 E-Stop Connector (A02B-0120-K321) • 2 Fuses (A06B-6089-K250) 	IC800APK130

* If required, amplifier package components can be ordered separately.

Section 3: α Series Servo System

The α Series Servo system consists of a motor and its corresponding amplifier. GE Fanuc offers several servo systems, which are identified in Table 5 below.

Table 5. Identification of servo systems

Parameter (Unit)	SERVO SYSTEM				
	$\alpha 6/3000$	$\alpha 12/3000$	$\alpha 22/2000$	$\alpha 30/3000$	$\alpha 40/2000$ (w/fan)
MOTOR					
Rated output power (kW)	1.4	2.8	3.8	4.8	7.3
Rated torque at stall (Nm) *	6.0	12	22	30	56
Rated torque at stall (in-lb) *	53	106	195	265	495
Rated torque at stall (kgf-cm) *	61	122	225	306	571
Rated output speed (RPM)	4000	3000	2000	3000	2000
Rotor inertia (kg m ²)	0.0026	0.0062	0.012	0.017	0.022
Rotor inertia (in-lb-s ²)	0.0174	0.0555	0.1041	0.1475	0.1996
Rotor inertia (kg-cm-s ²)	0.027	0.064	0.12	0.17	0.23
Continuous RMS current at stall A (rms)	10.0	15.5	18.7	33.7	40.1
Torque constant (Nm/A [rms]) *	0.60	0.77	1.17	0.89	1.40
Torque constant (in-lb/A [rms]) *	5.3	6.8	10.4	7.9	12.4
Torque constant (kgf-cm/A [rms]) *	6.1	7.9	12.0	9.1	14.3
Back EMF constant (V/1000 RPM) *	21	27	41	31	49
Back EMF constant (Vsec/rad) *	0.20	0.26	0.39	0.30	0.47
Armature resistance (Ω) *	0.18	0.17	0.140	0.046	0.080
Mechanical time constant (s) *	0.004	0.005	0.004	0.003	0.003
Thermal time constant (min)	50	60	65	70	30
Static friction (Nm)	0.3	0.8	1.2	1.8	1.8
Static friction (in-lb)	2.7	7.1	10.6	15.9	15.9
Static friction (kgf-cm)	3	8	12	18	18
Maximum allowable current (A [peak])	132	120	160	320	270
Maximum theoretical torque (Nm) **	56	66	130	200	270
Maximum theoretical torque (in-lb) **	496	584	1150	1770	2390
Maximum theoretical torque (kgf-cm) **	571	670	1400	2100	2800
Weight (kg)	13	18	29	41	55
Weight (lb)	28.6	39.6	63.8	90.2	121
AMPLIFIER					
Amplifier model	SVU1-80	SVU1-80	SVU1-80	SVU1-130	SVU1-130
Rated output current (rms amps)	18.7	18.7	18.7	52.2	52.2
Current limit (Peak amps)	80	80	80	130	130
Heat loss (watts)	37.7	47.3	54	70.9	80.7
230 VAC 1 ϕ control power current (A)	0.13	0.13	0.13	0.26	0.26
Weight (kg)	4.9	4.9	4.9	9.9	9.9
Weight (lb)	10.8	10.8	10.8	21.8	21.8

* These values are standard values at 20°C with a tolerance of $\pm 10\%$. The speed-torque characteristics vary, depending on the type of software, parameter setting, and input voltage of the digital servo amplifier. (The above figures show average values.) These values may be changed without prior notice.

** Theoretical values. The actual maximum torque is restricted by the current limit values of the drive amplifier.

Section 4: α Servo System Options

Designing a servo control system requires that you understand how the electrical and mechanical aspects of your system interact. GE Fanuc application engineers are available to help you determine your control system requirements.

Table 6 will help you select which servo options your system requires. Further details for each option are located in the sections indicated.

Table 6. α Series servo package options

Servo Option	Consider Selecting When	Catalog #	Section #
Motor Holding Brake	the system design includes an axis that must hold its position when power is removed	Motor option (see p. 6 for motor catalog #)	2.3
IP67 Sealing	to enable the motor to meet IEC standards for protection from solid objects and water	Motor option (see p. 6 for motor catalog #)	4.1
Absolute Encoder Battery Packs	you would like to avoid having to re-reference the position when power is restored to the control	IC800ABK001	4.2
AC Line Filters	200—240 VAC is already available to the control cabinet and no transformer is used. Line filters reduce harmonic noise into the servo power supply.	5.4 kW, 3-phase: A81L-0001-0083#3C 10.5 kW, 3-phase: A81L-0001-0101#C	6.2
Prefinished Cables	the cable lengths available from GE Fanuc are appropriate for your application	Refer to the “Cable Connection” table on p. 45	7.2
External Discharge Resistor	The internal regenerative discharge resistor is insufficient for the application. If required, the regen resistor must be ordered separately.	16 Ohm 200 Watt: A06B-6089-H500 16 Ohm 800 Watt: A06B-6089-H713 8 Ohm 800 Watt: A06B-6089-H711	6.6

4.1 IP67 SEALING OPTION ON α SERIES SERVO MOTORS

Most of the α Series servo motors can be ordered with IP67 Sealing. Motors with the IP67 Sealing meet the IEC standards regarding protection from solid objects and water, as described below:

Standard IP6x: Protection from Solid Objects

- Protected against solid objects greater than 1 mm thickness or diameter
- Dust tight. "No ingress of dust."

Standard IPx7: Protection from Water

- Protected against dripping water, rate equivalent to 3–5 mm of rain per minute
- Protected against splashing water from any direction
- Protected from harmful damage due to water jets, according to the following test:
 - Spray from all angles of 12.5 liters/minute (3.3 gal/min)
 - Nozzle diameter = 6.3 mm (0.248 in)
 - Pressure = 30 kN/m² (0.3 bar)
 - Distance = 3 m (118 in)
 - Duration = 3 minutes
- Protected from harmful Protected against the effects of immersion, according to the following test:
 - Surface of the water level shall be at least 150 mm (5.9 in) above the highest point of the machine
 - Lowest point of the machine must be at least 1 m (39.4 in) below the surface of the water
 - Duration of the test must be at least 30 minutes
 - Water temperature must not differ from that of the machine by more than 5° C

For more information, refer to CEI/IEC 34–5; 1991 and the GE Fanuc document *Servo and Spindle Motors Exposed to Liquids* (GFK-1046).

4.2 ABSOLUTE ENCODER BATTERY PACKS

All α Series servo motors feature a built-in serial encoder that can be used in either incremental or absolute mode. In order to utilize the absolute capability, an optional encoder battery pack (IC800ABK001) must be installed. This pack makes the encoder's position information non-volatile so that the machine does not need to be re-referenced to a home position every time power is restored to the servo system.

The Absolute Encoder Battery Kit (IC800ABK001) contains the following:

- One battery holder (A06B-6050-K060)
- Four D-cell, alkaline batteries (A98L-0031-0005)

One kit provides battery backup for up to four absolute encoders. A two-meter-long cable (44C741863-001) must be ordered separately for each servo axis connected to the battery pack. Kit components cannot be ordered separately.

The battery pack is panel-mounted and requires a cutout in the mounting surface. Mounting dimensions and terminal designations are shown below:

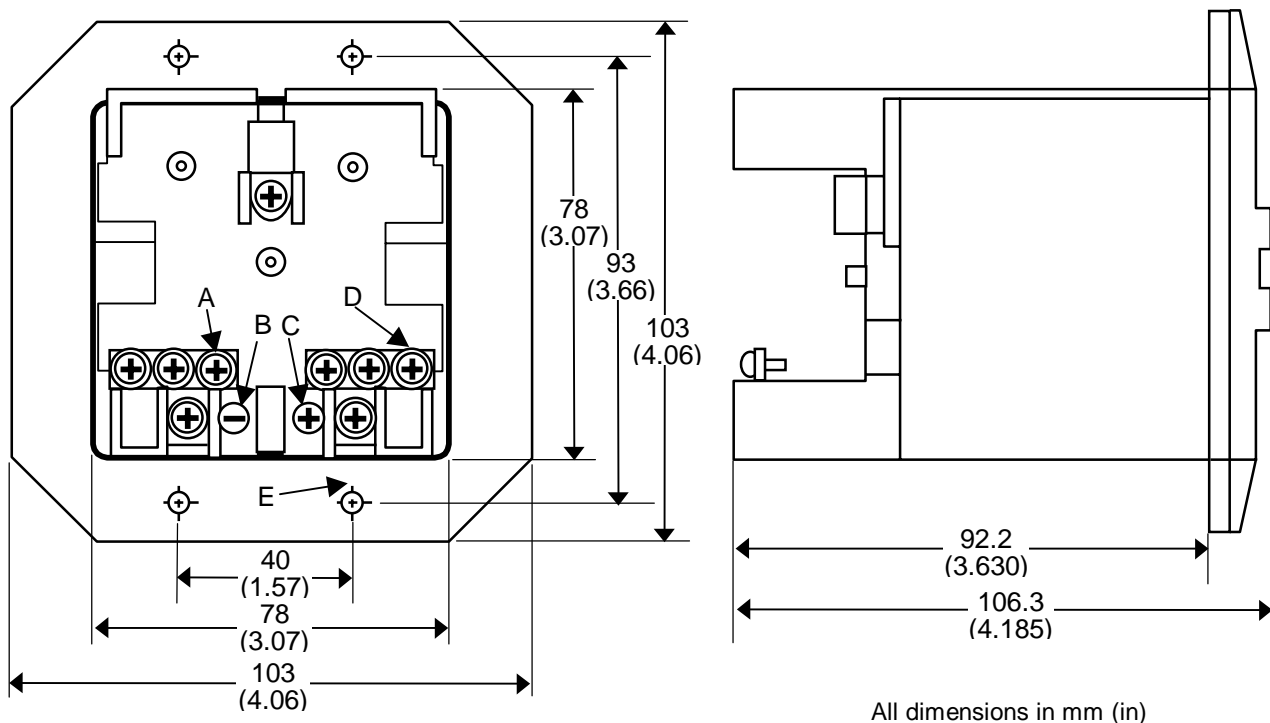

A	3-M3 negative terminal
B	Negative terminal indication
C	Positive terminal indication
D	3-M3 positive terminal
E	4-Ø4.3 (0.169) mounting holes

Figure 4. Absolute encoder battery pack

Section 5: Installation Guidelines

This section includes environmental requirements, motor and amplifier dimension drawings and information on ensuring noise protection and selecting a ground fault interrupter.

5.1 MOTOR ENVIRONMENTAL REQUIREMENTS

The servo motor must be installed in a location that satisfies the following environmental conditions:

Table 7. Servo amplifier environmental conditions

Condition	Description
Ambient temperature	The ambient temperature should be -10°C to 40°C. When operating the machine at a temperature higher than 40°C (55°C max), it is necessary to derate the output power so that the motor's temperature rating is not exceeded.
Vibration	When installed in a machine, the vibration applied to the motor must not exceed 5G.
Altitude	No more than 1,000 m (3,300 ft) above sea level.
Drip-Proof Environment	The motors have a drip-proof structure that complies with IP65 of the IEC standard. Optional IP67 Sealing, available on most α Series servo motors, offers further protection from liquids (see Section 4.1 for more details). Nevertheless, to ensure long-term performance, the motor surface should be protected from solvents, lubricants, and fluid spray. A cover should be used when there is a possibility of wetting the motor surface. Also, to prevent fluid from being led to the motor through the cable, put a drip loop in the cable when the motor is mounted. Finally, turn the motor connector sideways or downward as far as possible. If the cable connector will be subjected to moisture, it is recommended that an R class or waterproof plug be used.

For additional information, see GE Fanuc publication *Servo and Spindle Motors Exposed to Liquids*, GFK-1046.

5.2 SERVO AMPLIFIER ENVIRONMENTAL REQUIREMENTS

The servo amplifier must be installed in a location that satisfies the environmental conditions identified in Table 8 below.

Table 8. Servo amplifier environmental conditions

Condition	Description
Ambient temperature	0°C to 55°C (operating). -20°C to 60°C (storage and transportation).
Temperature fluctuation	Within 1.1°C/min.
Humidity	30% to 95% RH (no condensation).
Altitude	No more than 1000 m (3,300 ft) above sea level.
Vibration	No more than 0.5 G during operation.
Atmosphere	The circuitry and heat sink must not be exposed to any corrosive and conductive vapor or liquid.

The amplifier must be installed in a cabinet that protects it from contaminants such as dust, coolant, organic solvents, acid, corrosive gas, and salt. Adequate protection must also be provided for applications where the amplifier could be exposed to radiation, such as microwave, ultraviolet, laser light, or x-rays.

In order to adequately protect the amplifier, you must ensure that:

- Contaminants such as dust and coolant, cannot enter through the air inlet or outlet.
- The flow of cooling air is not obstructed.
- The amplifier can be accessed for inspection.
- The amplifier can be disassembled for maintenance and later reinstalled.
- There is sufficient separation between the power and signal lines to avoid interference. Noise protection should be provided.

5.3 α SVU SERIES SERVO AMPLIFIER HEAT DISSIPATION

To determine the heat generated by an α Series SVU amplifier with a particular motor, use the table that follows. The α SVU Series amplifiers are mounted with their heat sink extending through a panel cut out in the control enclosure. This design eliminates most of the heat dissipation inside the control cabinet.

Table 9. Servo amplifier heat dissipation

Motor Model	Amplifier Model	Total Dissipation	Dissipation Inside Cabinet
α6/3000	α SVU1-80	73 W	38 W
α12/3000	α SVU1-80	106 W	47 W
α22/2000	α SVU1-80	127 W	54 W
α30/3000	α SVU1-130	228 W	71 W
α40/2000 w/ Fan	α SVU1-130	276 W	81 W

The following notes apply to the heat values:

- The heat dissipation values are worst case values when motors are run at their continuous output ratings.
- If the heat sink of the amplifier is installed outside the cabinet or if a separate regenerative resistor is installed outside the cabinet, it is unnecessary to add the heat generated by the regenerative resistor to the total heat generated by the cabinet. If the heat sink of a built-in or separate regenerative resistor is installed inside the cabinet, it is necessary to add the heat generated by the regenerative resistor to the heat generated by the cabinet. See Section 6.6 for more information.

5.4 α SERIES MOTOR DIMENSIONS

5.4.1 α6/3000

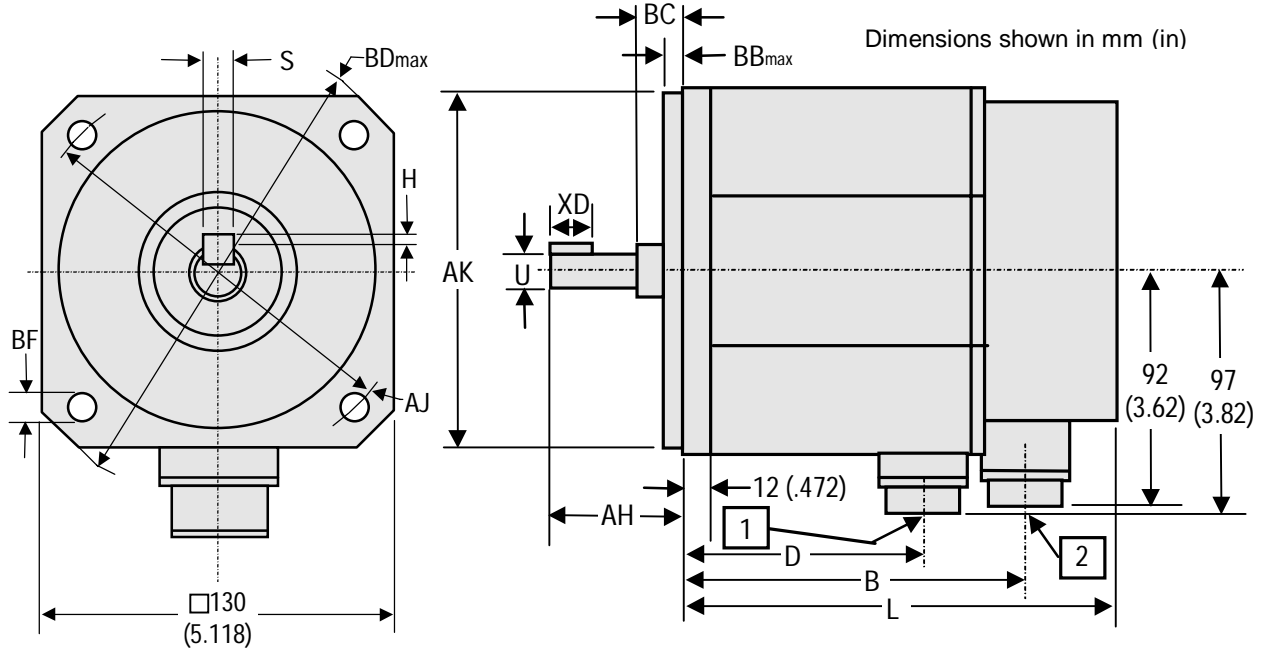

Dim.	MOTOR
	α6/3000
S	6 ⁺⁰ _{-0.030} mm (0.2362/0.235 in)
H	2.5 ⁺⁰ _{-0.013} (0.0984/0.0933)
BD	165 (6.496)
AJ (dia)	145 (5.709)
BF (dia)	9 (0.354)

Dim.	MOTOR
	α6/3000
BB	6 mm (.236 in)
XD	36 (1.417)
AK	110 ⁺⁰ _{-0.035} (4.331/4.329)
U	19 ⁺⁰ _{-0.013} (0.7480/0.7475)
BC	15±0.5 (0.610/0.571)
AH	55 (2.165)
D	176 (6.93)
B	221 (8.70)
L	259 (10.20)

Connector	Description
1	Motor AC Power Connector
2	Motor Encoder Feedback Connector

NOTES

1. See the α Connection section (Section 7:) for more information about motor cables.
2. Shaft diameter runout = 0.02 mm max (0.00079 in).
3. Flange surface runout = 0.06 mm max (0.00236 in).
4. Rabbet diameter eccentricity = 0.02 mm max (0.00079 in).
5. Maximum radial load for output shaft is 70 kgf (31.8 lb).

Figure 5. α 6/3000 motor, front and side views

5.4.2 α6/3000 with brake, side view

(Front view same as α6/3000 without brake)

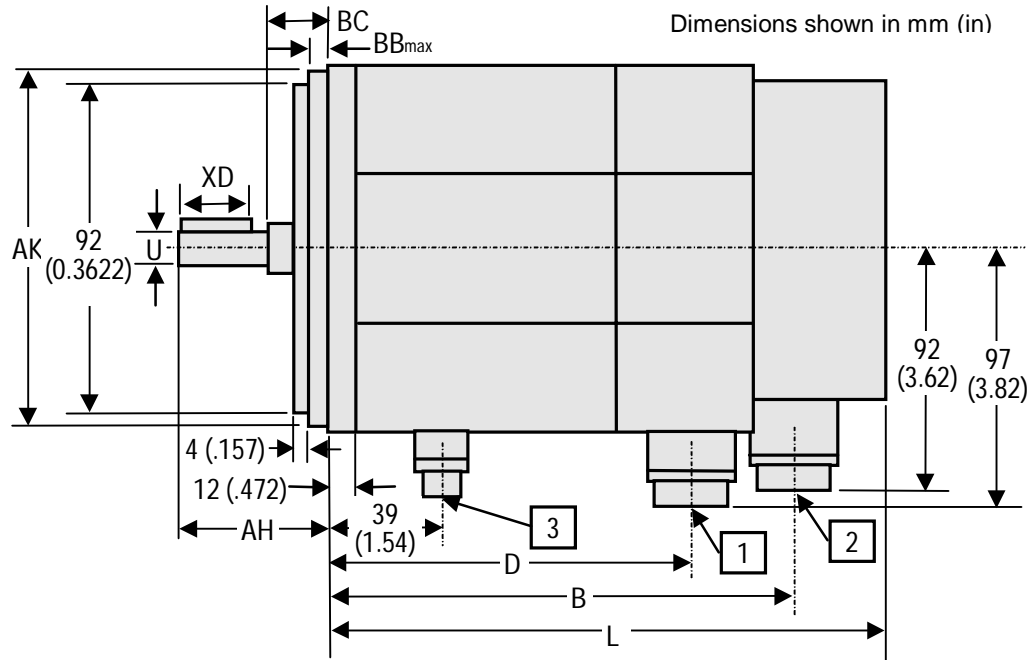

Dim.	MOTOR
	α6/3000 w/ brake
BB	6 mm (0.236 in)
XD	36 (1.917)
AK	110 ⁺⁰ _{-0.035} (4.331/4.329)
U	19 ⁺⁰ _{-0.013} (0.7480/0.7475)
BC	221 (8.70)
AH	55 (2.165)
D	225 (8.858)
B	270 (10.63)
L	309 (12.17)

Connector	Description
1	Motor AC Power Connector
2	Motor Encoder Feedback Connector
3	Brake Connector

NOTES

1. See the α Connection section (Section 7:) for more information about motor cables.
2. Shaft diameter runout = 0.02 mm max (0.00079 in).
3. Flange surface runout = 0.06 mm max (0.00236 in).
4. Rabbet diameter eccentricity = 0.04 mm max (0.00157 in).
5. Maximum radial load for output shaft is 70 kgf (31.8 lb).

Figure 6. α 6/3000 motor with brake, side view

5.4.3 α12/3000, α22/2000, and α30/3000, front view

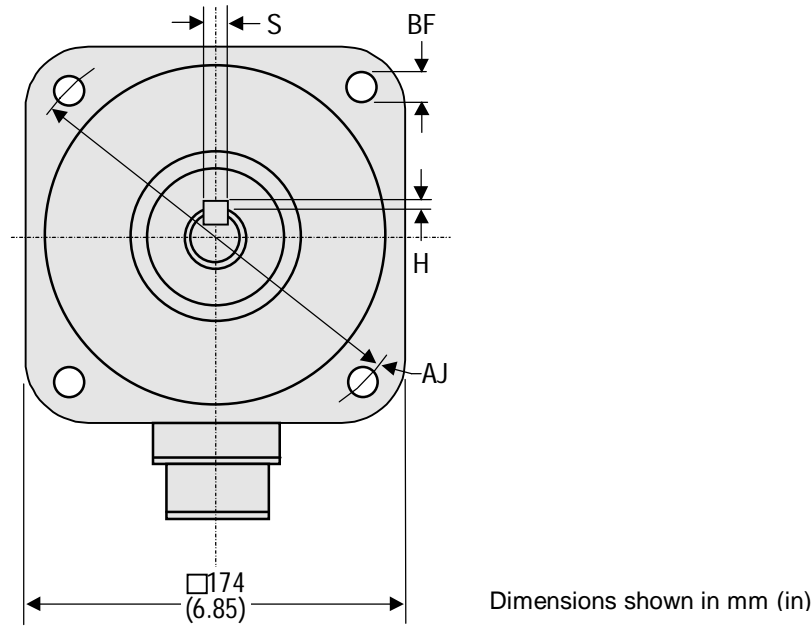

Dim.	MOTOR		
	α12/2000	α22/2000	α30/3000
S	10 ⁺⁰ _{-0.036} mm (0.3937/0.3923 in)	10 ⁺⁰ _{-0.036} mm (0.3937/0.3923 in)	10 ⁺⁰ _{-0.036} mm (0.3937/0.3923 in)
H	3 ⁺⁰ _{-0.30} (0.1181/0.1063)	3 ⁺⁰ _{-0.30} (0.1181/0.1063)	3 ⁺⁰ _{-0.30} (0.1181/0.1063)
BF	13.5 (0.532)	13.5 (0.532)	13.5 (0.532)
AJ	200 (7.874)	200 (7.874)	200 (7.874)

NOTES FOR ALL VIEWS (see Section 5.4.4 for side view and Section 5.4.5 for side view with brake)

1. See the α Connection section (Section 7.2) for more information about motor cables.
2. Shaft diameter runout = 0.05 mm max (0.00197 in).
3. Flange surface runout = 0.10 mm max (0.00394 in).
4. Rabbet diameter eccentricity = 0.07 mm (0.00276 in).
5. Maximum radial load for output shaft is 450 kgf (204 lb).
6. Taps for eyebolts are M8 by 15 mm (.591 in) deep; eyebolts are not attached.

Figure 7. α 12/3000, α22/2000, and α30/3000 motors, front view

5.4.4 α12/3000, α22/2000, and α30/3000, side view

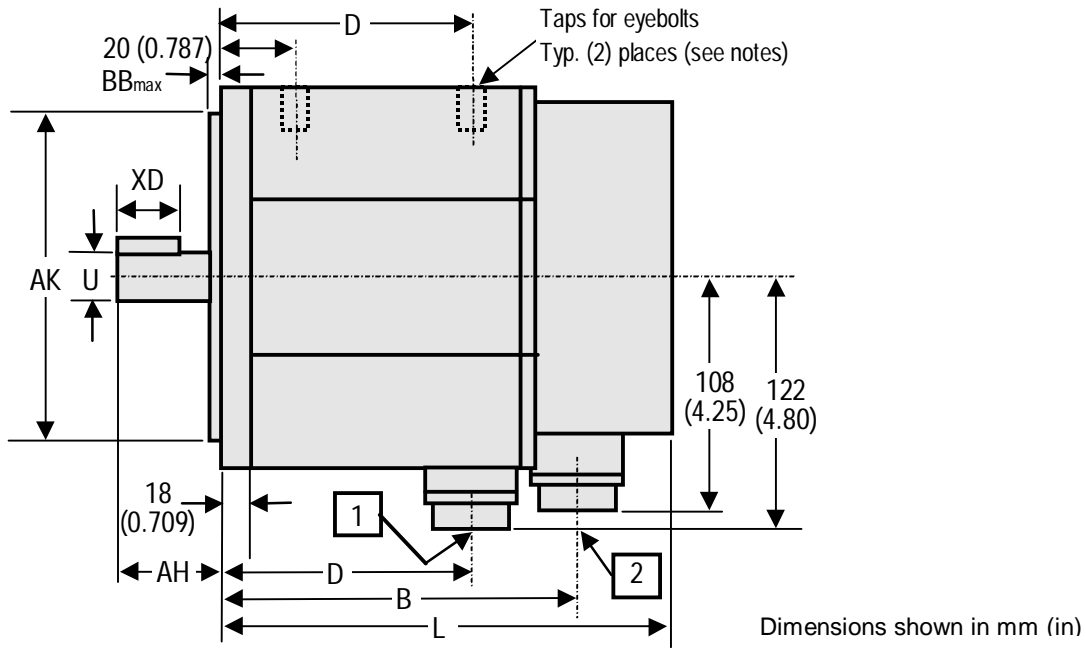

Dimen.	MOTOR		
	α12/2000	α22/2000	α30/3000
BB	3.2 mm (0.126 in)	3.2 mm (0.126 in)	3.2 mm (0.126 in)
XD	70 (2.756)	70 (2.756)	70 (2.756)
AK	114.3 ⁺⁰ _{-0.025} (4.50/4.499)	114.3 ⁺⁰ _{-0.025} (4.50/4.499)	114.3 ⁺⁰ _{-0.025} (4.50/4.499)
U	35 ^{+0.01} ₋₀ (1.3784/1.3779)	35 ^{+0.01} ₋₀ (1.3784/1.3779)	35 ^{+0.01} ₋₀ (1.3784/1.3779)
AH	79 (3.11)	79 (3.11)	79 (3.11)
D	166 (6.535)	240 (9.449)	314 (12.362)
B	215 (8.465)	289 (11.378)	363 (14.291)
L	240 (9.45)	314 (12.36)	388 (15.28)

Connector	Description
1	Motor AC Power Connector
2	Motor Encoder Feedback Connector

Figure 8. α 12/3000, α22/2000, and α30/3000 motors, side view

5.4.5 α12/3000, α22/2000, and α30/3000 with brake, side view

(Front view same as α12/3000, α22/2000, and α30/3000 without brake; see also Notes in Section 5.4.3)

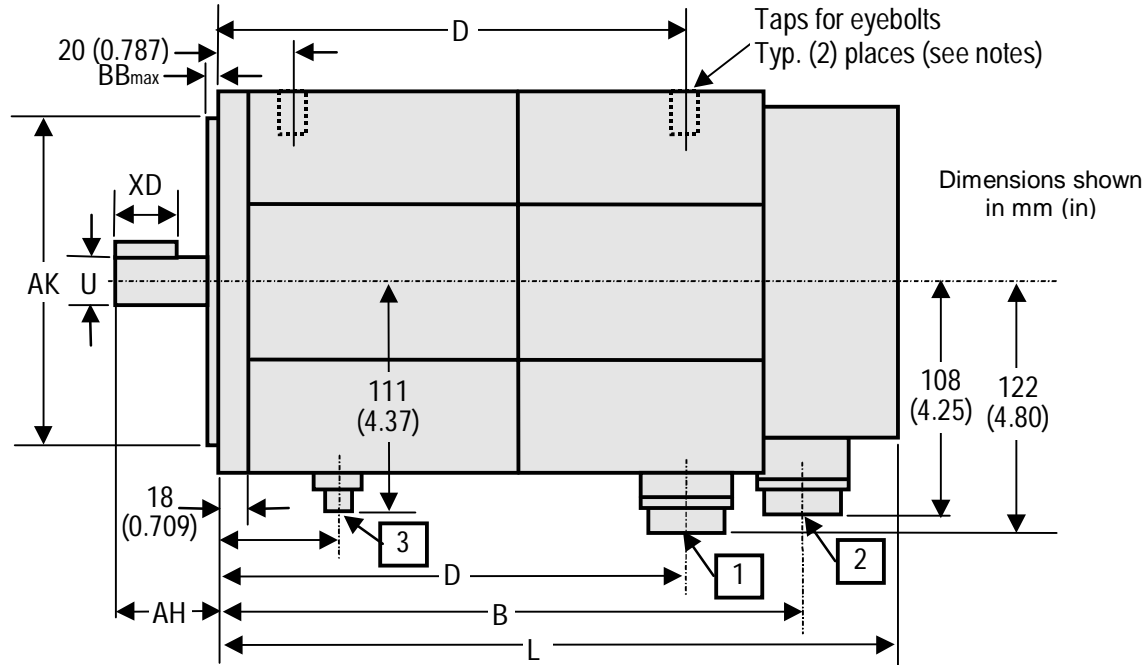

Dimension	MOTOR		
	α12/2000 w/brake	α22/2000 w/brake	α30/3000 w/brake
BB	3.2 mm (0.126 in)	3.2 mm (0.126 in)	3.2 mm (0.126 in)
XD	70 (2.756)	70 (2.756)	70 (2.756)
AK	114.3 ⁺⁰ _{-0.025} (4.50/4.499)	114.3 ⁺⁰ _{-0.025} (4.50/4.499)	114.3 ⁺⁰ _{-0.025} (4.50/4.499)
U	35 ^{+0.01} ₋₀ (1.3784/1.3779)	35 ^{+0.01} ₋₀ (1.3784/1.3779)	35 ^{+0.01} ₋₀ (1.3784/1.3779)
AH	79 (3.11)	79 (3.11)	79 (3.11)
D	238 (9.37)	312 (12.28)	386 (15.20)
B	287 (11.30)	361 (14.21)	435 (17.13)
L	312 (12.28)	386 (15.20)	460 (18.11)

Connector	Description
1	Motor AC Power Connector
2	Motor Encoder Feedback Connector
3	Brake Connector

Figure 9. α 12/3000, α22/2000, and α30/3000 motors with brake, side view

5.4.6 α40/2000 with fan, front and rear views

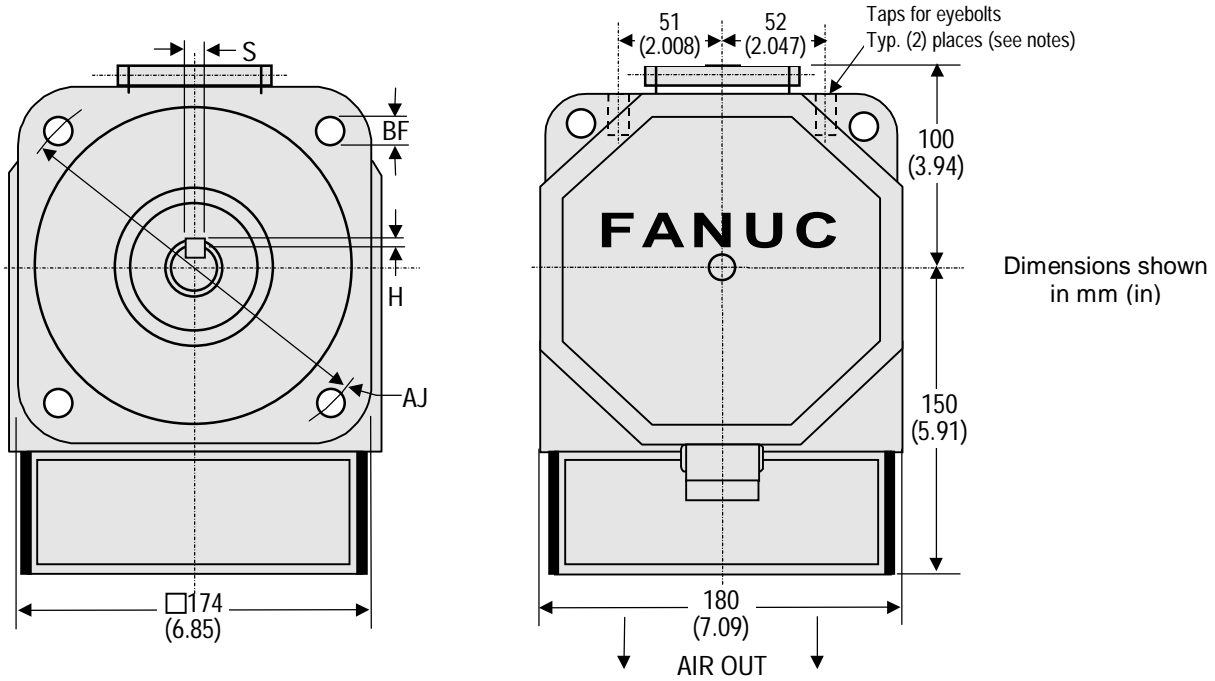

Dim.	MOTOR
	α40/2000 w/fan
S	10 ⁺⁰ _{-0.036} mm (0.3937/0.3923 in)
H	3 ⁺⁰ _{-0.30} (0.1181/0.1063)
BF (dia.)	13.5 mm (0.531 in)
AJ (dia.)	200 (7.874)

NOTES FOR ALL VIEWS (see Sections 5.4.7 and 5.4.8 for top and side views)

1. See Section 7.2 for more information about motor cables.
2. Shaft diameter runout = 0.05 mm max (0.00197 in).
3. Flange surface runout = 10.10 max (0.00394 in).
4. Maximum radial load for output shaft is 450 kgf (990 lb).
5. Taps for eyebolts are M8 by 15 mm (.591 in) deep; eyebolts are not attached.
6. Rabbet diameter eccentricity = 0.07 mm max (0.00276 in).
7. Direction of air flow is downward only.

Figure 10. α 40/2000 with fan, front and rear views

5.4.7 α40/2000 with fan, top and side views

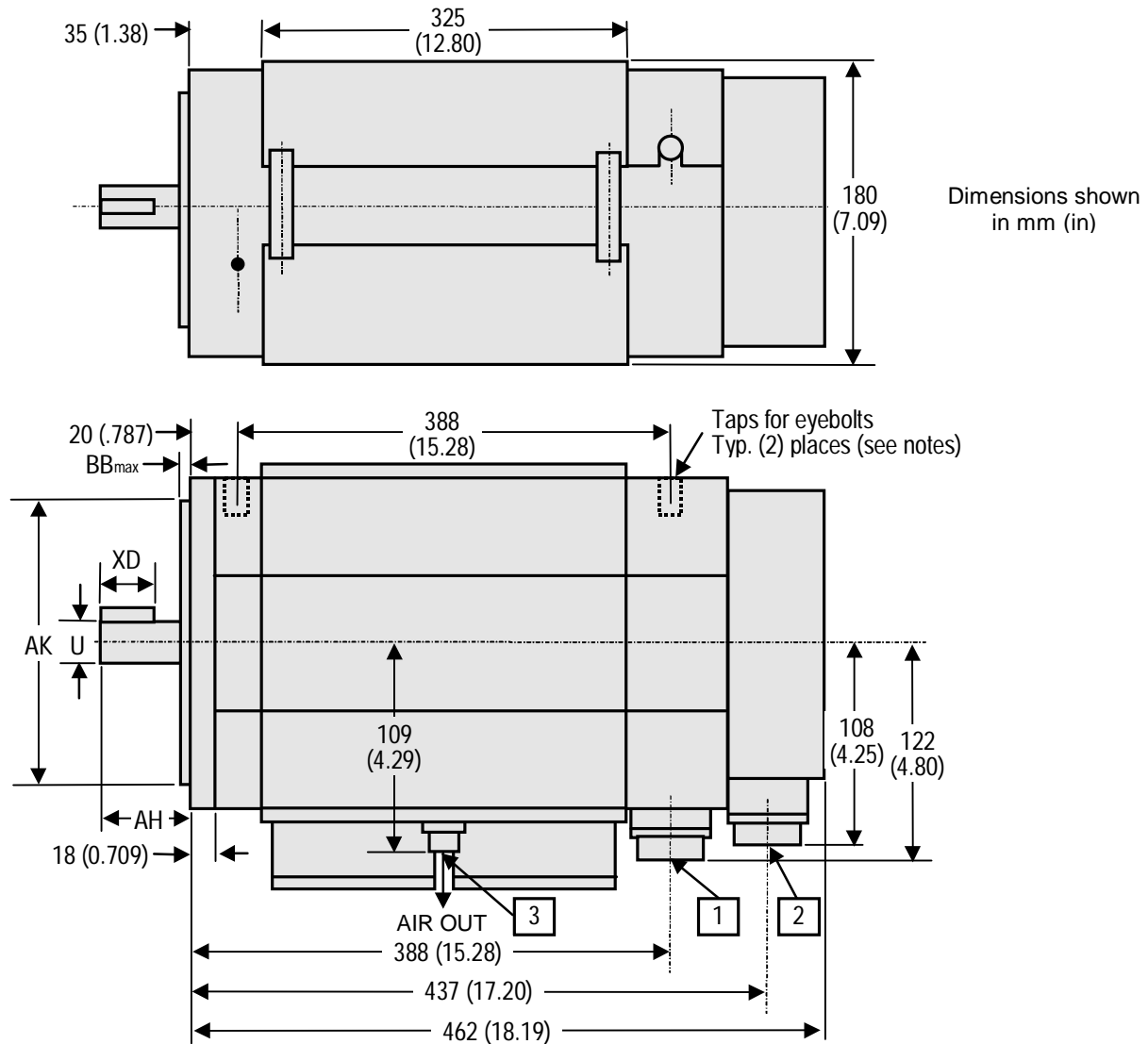

Dim.	MOTOR
	α40/2000 w/fan
BB	3.2 mm (0.126 mm)
XD	70 (2.756)
AK	114.3 ⁺⁰ _{-0.025} (4.50/4.499)
U	35 ^{+0.01} ₋₀ (1.3784/1.3779)
AH	79 (3.11)

Connector	Description
1	Motor AC Power Connector
2	Motor Encoder Feedback Connector
3	Fan Connector

Figure 11. α 40/2000 motor with fan, top and side views

5.4.8 α40/2000 with fan and brake, top and side views

(Front and rear views same as α40/2000 with fan and without brake)

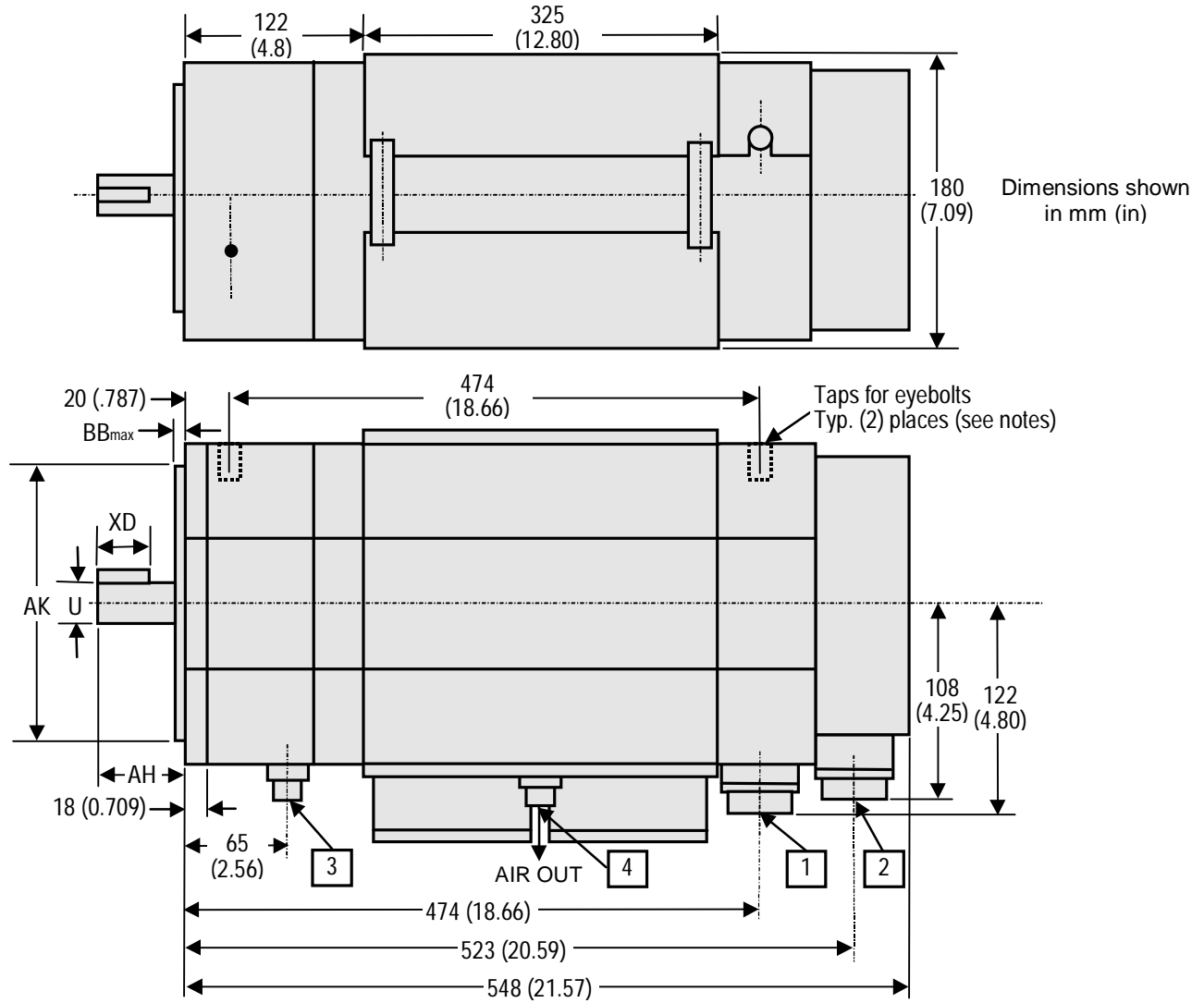

Dim.	MOTOR
	α40/2000 w/fan
BB	3.2 mm (0.126 in)
XD	70 (2.756)
AK	114.3 ⁺⁰ _{-0.025} (4.50/4.499)
U	35 ^{+0.01} ₋₀ (1.3784/1.3779)
AH	79 (3.11)

Connector	Description
1	Motor AC Power Connector
2	Motor Encoder Feedback Connector
3	Brake Connector
4	Fan Connector

Figure 12. α 40/2000 motor with fan and brake, top and side views

5.5 SHAFT LOADING:

The allowable load of the motor shaft is as follows:

Table 10. Allowable motor shaft load

Motor Model	Radial Load	Axial Load	Front Bearing Type
α 6/3000	70 kg (31.8 lb)	20 kg (9.1 lb)	6205
α 12/3000, α 22/2000, α 30/3000, α 40/2000 w/ fan	450 kg (204 lb)	135 kg (61.4 lb)	6208

NOTES:

- The allowable radial load is the value when a load is applied to the shaft end. It indicates the total continuous force applied to the shaft in some methods of mounting (for example, belt tension) and the force by load torque (for example, moment/pulley radius).
- The belt tension is critical particularly when a timing belt is used. Belts that are too tight may cause breakage of the shaft or premature bearing failure. Belt tension must be controlled so as not to exceed the limits calculated from the permissible radial load indicated above.
- In some operating conditions, the pulley diameter or gear size needs to be checked. For example, when using the model α 6/3000 with a pulley/gear with a radius of 1.5 cm (2 in) or less, the radial load when 230 in-lb of peak torque is provided by the motor will exceed the 154 lb maximum rating. In the case of the timing belt, the belt tension is added to this value, making it necessary to support the shaft end.
- When using a timing belt, shaft failure or bearing overload can be minimized by positioning the pulley as close to the bearing as possible.
- Since a standard single row, deep-groove ball bearing is used for the motor bearing, a very large axial load cannot be used. Particularly when using a worm gear and a helical gear, it is necessary to provide another bearing to isolate the thrust load from the searing.
- The motor bearing is generally fixed with a C-snap ring, and there is a small play in the axial direction. When this play influences the positioning in the case of using a worm gear and a helical gear, for example, it is necessary to use an additional bearing support.

5.6 α SVU1 SERIES AMPLIFIER AND PANEL CUTOUT DIMENSIONS

The α SVU Series amplifiers are designed with a rear-mounted heat sink that extends through a hole in the mounting plate. This design eliminates most of the heat dissipation inside the control cabinet reducing the temperature rise in the cabinet and the load on cabinet cooling equipment.

This section contains front and side views as well as the panel cutout drawings for the SVU1-80 and SVU1-130 servo amplifier units.

5.6.1 α SVU1-80 and SVU1-130 dimension drawings

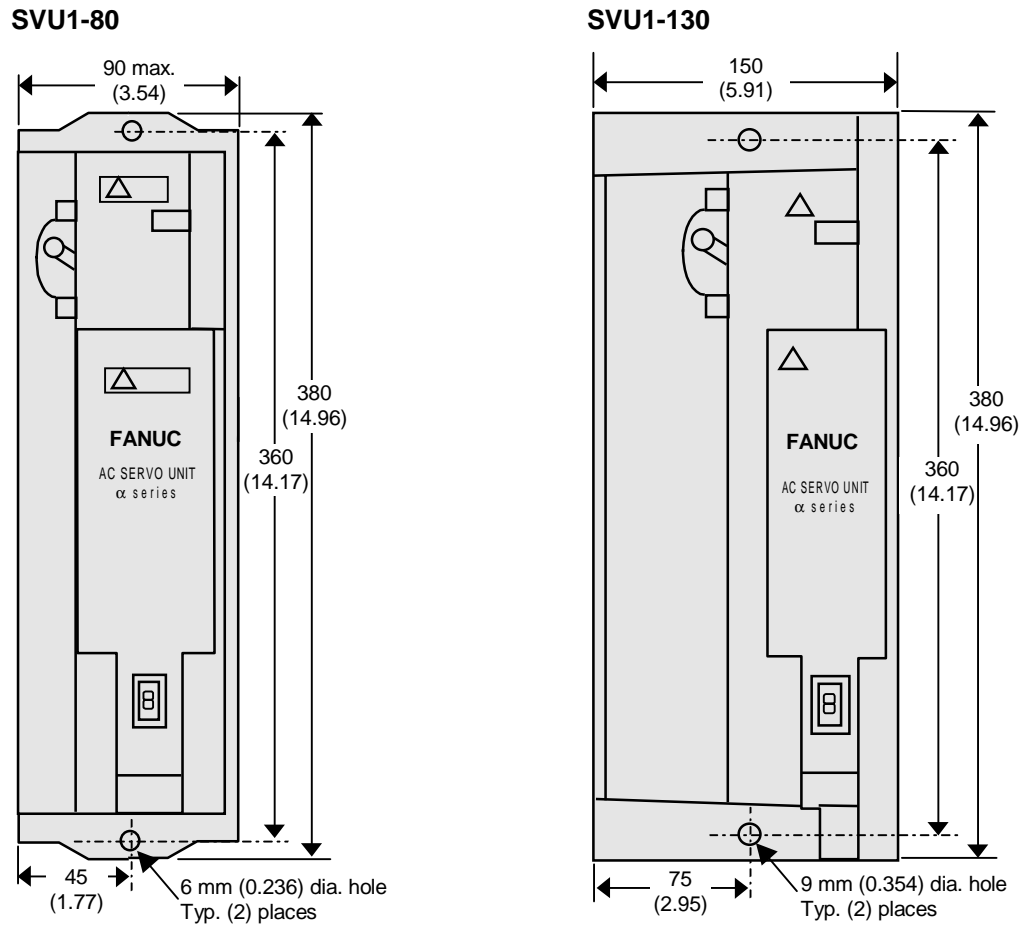

Dimensions shown in mm (in)

Figure 13. Front view of αSVU1-80 and αSVU1-130 servo amplifiers

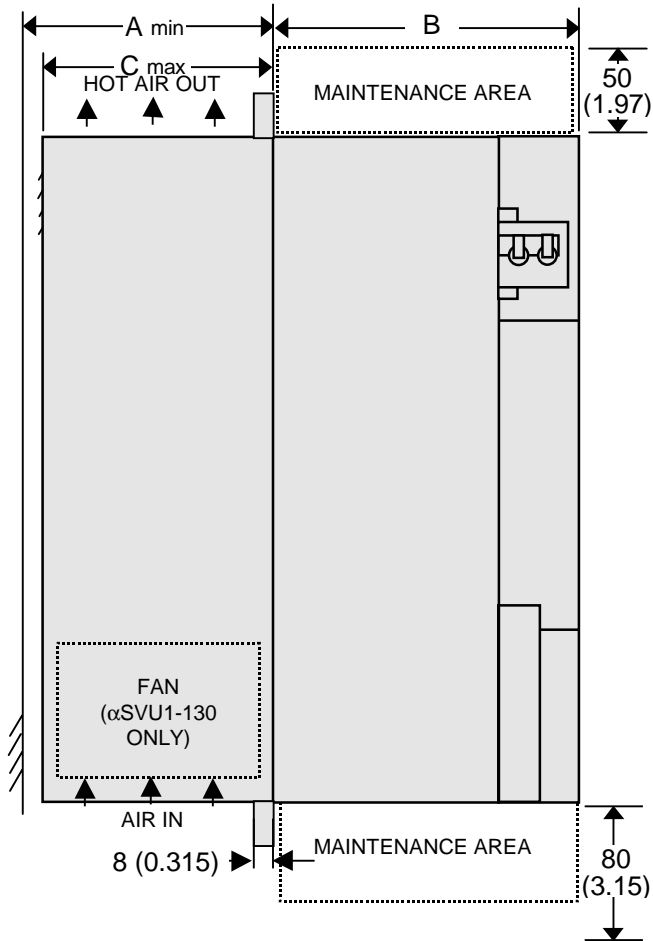

Dim.	SVU1-80	SVU1-130
A	135 mm (5.31 in)	135 mm (5.31 in)
B	165 (6.50)	175 (6.89)
C	120 (4.72)	130 (5.12)

Dimensions shown in mm (in)

Figure 14. Side view of α SVU1-80 and α SVU1-130 servo amplifiers

NOTE

The α SVU Series amplifiers and regenerative discharge units have rear heat sink extensions designed to protrude through the customer's control cabinet. This design allows the amplifier's heat to be dissipated outside the control cabinet, reducing the load on enclosure cooling equipment. Panel cut out drawings are shown on the next page.

5.6.2 α SVU1-80 and SVU1-130 panel cutout drawings

SVU1-80

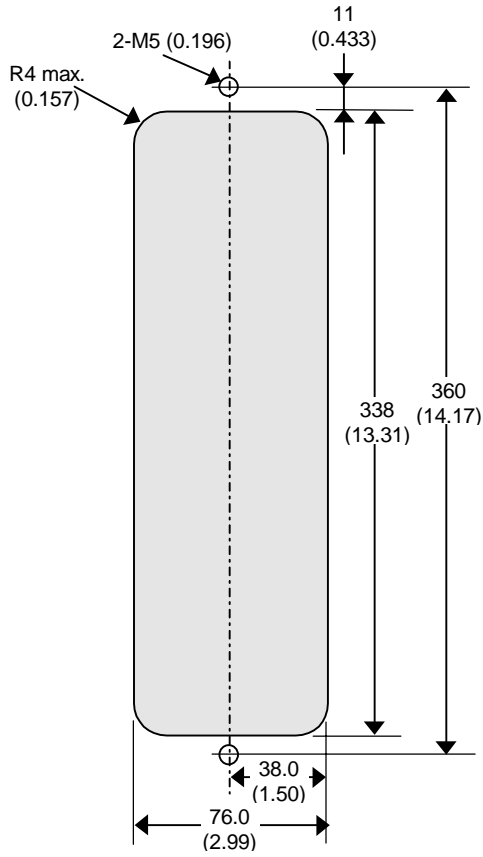

SVU1-130

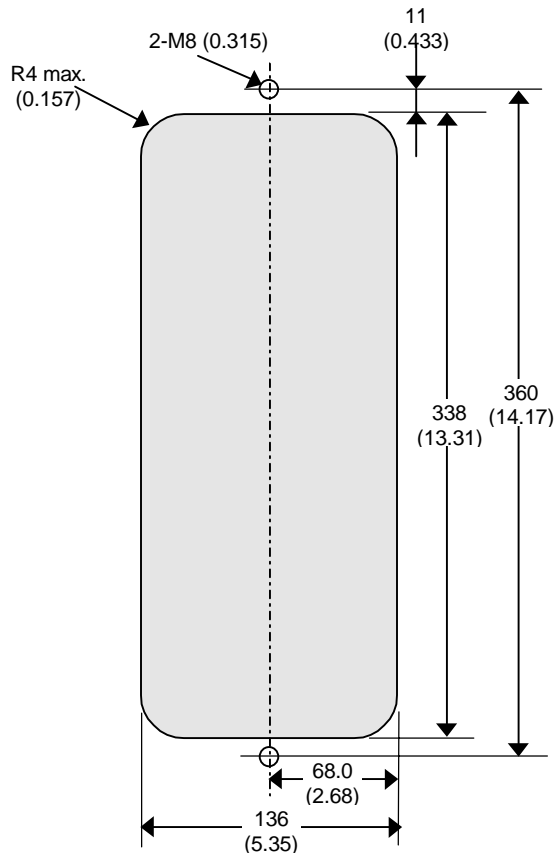

Dimensions shown in mm (in)

Figure 15. Panel cut out drawings of α SVU1-80 and α SVU1-130 servo amplifiers

5.7 α SVU SERIES SWITCH SETTINGS

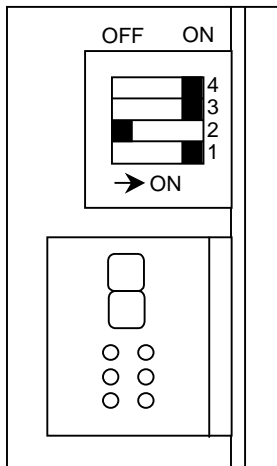

There are four channel switches located above the 7-segment LED and behind the terminal board cover on the front of the α Series servo amplifiers. These switches should be set as described below before use of the α SVU series servo amplifiers.

Figure 16. α SVU Series channel switches

Positions:

The switches are sequentially numbered 1, 2, 3, and 4 with the one at the bottom as switch 1. The OFF position is on the left, and the ON position is on the right.

Switch 1 Setting:

Always set to ON.

Switch 2 Setting:

Always set to OFF for α SVU1 Series.

NOTE: If the switch 2 setting is incorrect, the VRDY OFF alarm may occur.

Switch 3 and 4 Setting:

The setting of these switches depends on the regenerative discharge resistance used:

Table 11. Switch 3 and 4 setting for α SVU1 Series amplifiers

SVU1-80			SVU1-130		
Regen. Discharge Unit	SW3	SW4	Regen. Discharge Unit	SW3	SW4
Built-in (100 W)	ON	ON	Built-in (400 W)	ON	ON
Separate A06B-6089-H500 (200 W)	ON	OFF	Separate A06B-6089-H711 (800 W)	ON	OFF
Separate A06B-6089-H713 (800 W)	OFF	OFF			

5.8 NOISE PROTECTION

5.8.1 Separation of Signal and Power Lines

When routing signal and power lines, the signal lines must be separated from the power lines to ensure best noise immunity. Table 12 below lists the types of cables used:

Table 12. Servo amplifier signal line separation

Group	Signal	Action
A	Amplifier input power line, motor power line, MCC drive coil	Separate these cables from those of group B by bundling them separately* or by means of electromagnetic shielding**. Attach a noise preventer or suppressor, such as a spark arrester, to the MCC drive coil.
B	Cable connecting control unit with servo amplifier and serial encoder feedback cable	Separate these cables from those of group A by bundling them separately or by means of electromagnetic shielding**. In addition, shielding must be provided.

* The bundle of group A cables must be separated from the bundle of group B cables by at least 10 cm.

** Electromagnetic shielding involves shielding groups from each other by means of a grounded metal (steel) plate.

5.8.2 Grounding

A typical machine has three separate grounds:

- **Signal Ground:** Provides the reference potential (0 V) for the electrical signal system.
- **Frame Ground:** Ensures safety and shields external and internal noise.
- **System Ground:** Connects each unit and the inter-unit frame ground system to earth ground.

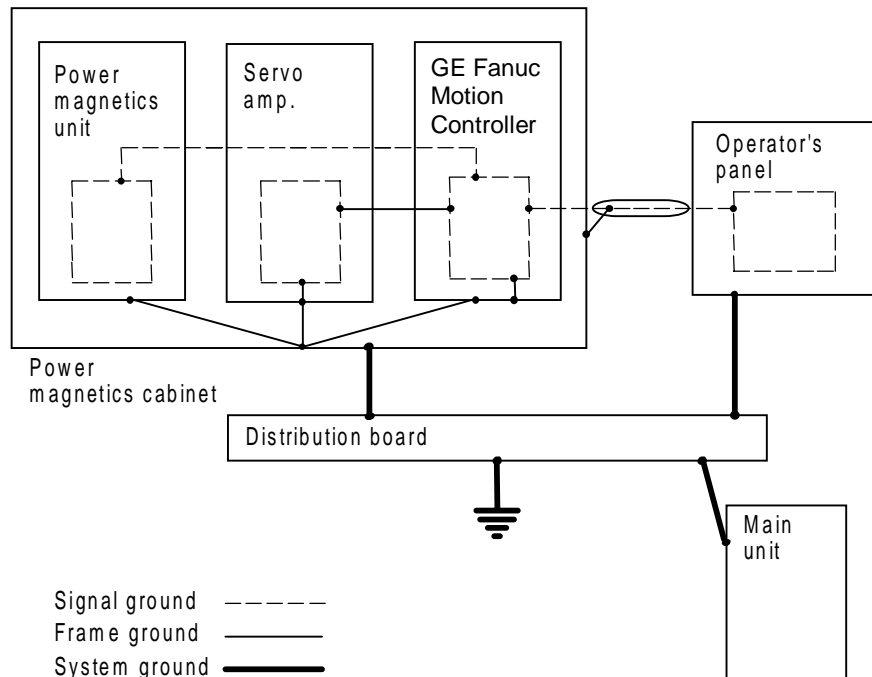

Figure 17. Ground system

Notes on the ground system wiring for α SVU1 Series amplifiers:

- The ground resistance of the system ground must not exceed 100 ohms (Class-3 ground).
- System ground connection cables must have a sufficiently large cross-sectional area to enable them to safely carry the current that will arise in the event of a problem such as a short-circuit (in general, a cross-sectional area no less than that of the AC power line must be provided).
- The system ground connection cable must be integrated with the AC power line such that power cannot be supplied if the ground wire is disconnected.

5.9 COMMAND CABLE GROUNDING

The GE Fanuc controller cables that require shielding should be clamped by the method shown below. This cable clamp treatment provides both cable support (strain relief) and proper grounding of the shield. To ensure stable system operation, the cable clamp method is recommended. Partially peel back the cable sheath to expose the shield. Push the clamp (A99L-0035-0001) over the exposed shield and insert the clamp hooks into slots on the grounding bar (44B295864-001). Tighten the clamp to secure cable and complete the ground connection. The grounding bar must be attached to a low impedance earth ground.

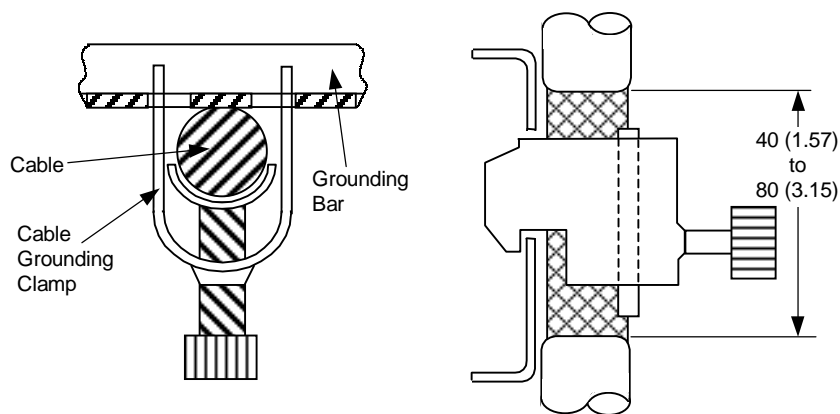

Grounding

Figure 18. Cable grounding clamp detail

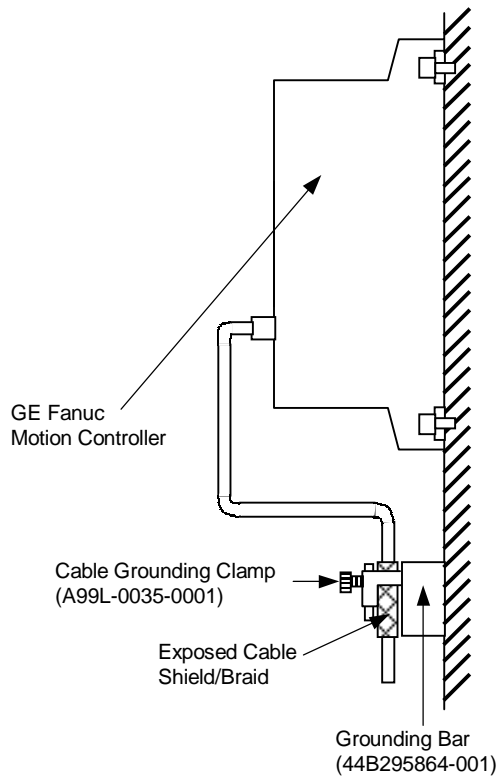

Figure 19. Command cable shield grounding system

5.10 SELECTING A GROUND FAULT INTERRUPTER

The α Series servo amplifier drives a motor by means of the transistor-based PWM inverter method, in which a high-frequency leakage current flows to ground through the stray capacitance of the motor windings, power cable, and amplifier. A ground fault interrupter or leakage-protection relay, which is installed on the power supply side, can malfunction if such a leakage current should flow. Therefore, you should select an inverter-compatible ground fault interrupter capable of handling the approximate leakage currents shown below in order to protect against the occurrence of this malfunction:

- **$\alpha 6/3000$** : choose a 1.8 mA commercial frequency component.
- **$\alpha 12/3000$, $\alpha 22/2000$** : choose a 2.0 mA commercial frequency component.
- **$\alpha 30/3000$, $\alpha 40/2000$** : choose a 2.5 mA commercial frequency component.

Section 6: α Servo System Power Requirements

This section provides information about AC amplifier power as well as the discharge of regenerative power.

6.1 POWER LINE PROTECTION

A circuit breaker, electromagnetic contactor and AC line filter or transformer should be installed as part of your α Series Servo system. GE Fanuc provides the AC line filter as an option. The transformer, circuit breaker, and electromagnetic contactor, however, are user-supplied components. In European countries where power sources are 380 to 400 VAC and neutral grounded, it is necessary to install a transformer.

The same incoming AC control components can be used to provide power to multiple amplifiers, as long as the components are rated for the current and power drawn by the sum of all of the amplifiers.

6.2 AC LINE FILTER

An AC line filter is recommended to suppress the influences of high-frequency input line noise on the drive power supply. When an isolation-type power transformer is used because a power supply voltage within the specified range is not available, an AC line filter is not required.

If two or more servo amplifiers are connected to one AC line filter, the total continuous output rating of all connected servo amplifiers should be kept below the continuous output rating of the AC line filter. The continuous output rating for the various servos are shown below.

Table 13. α servo motor continuous output rating

Motor	Cont. Output Rating
α 6/3000	1.4 kW
α 12/3000	2.8 kW
α 22/2000	3.8 kW
α 30/3000	4.8 kW
α 40/2000 with fan	7.3 kW

If your installation must be EMC compliant, verify that the use of an AC line filter fully satisfies the EMC requirements. You may need to select and install a user-supplied noise filter in order to meet EMC requirements.

GE Fanuc offers two AC line filters from GE Fanuc:

- 5.4 kW, 3-phase (A81L-0001-0083#3C)
- 10.5 kW, 3-phase (A81L-0001-0101#C)

Table 14. AC line filter specifications

Specification	5.4 kW	10.5 kW
Continuous rated current	24A	44A
Max. continuous rated power	5.4kW	10.5kW
Heat dissipation	20W	70W
Weight	1.1 kg (2.4 lb)	3.0 kg (6.6 lb)
Catalog Number	(A81L-0001-0083#3C)	(A81L-0001-0101#C)

The dimensions of the AC line filters are as follows

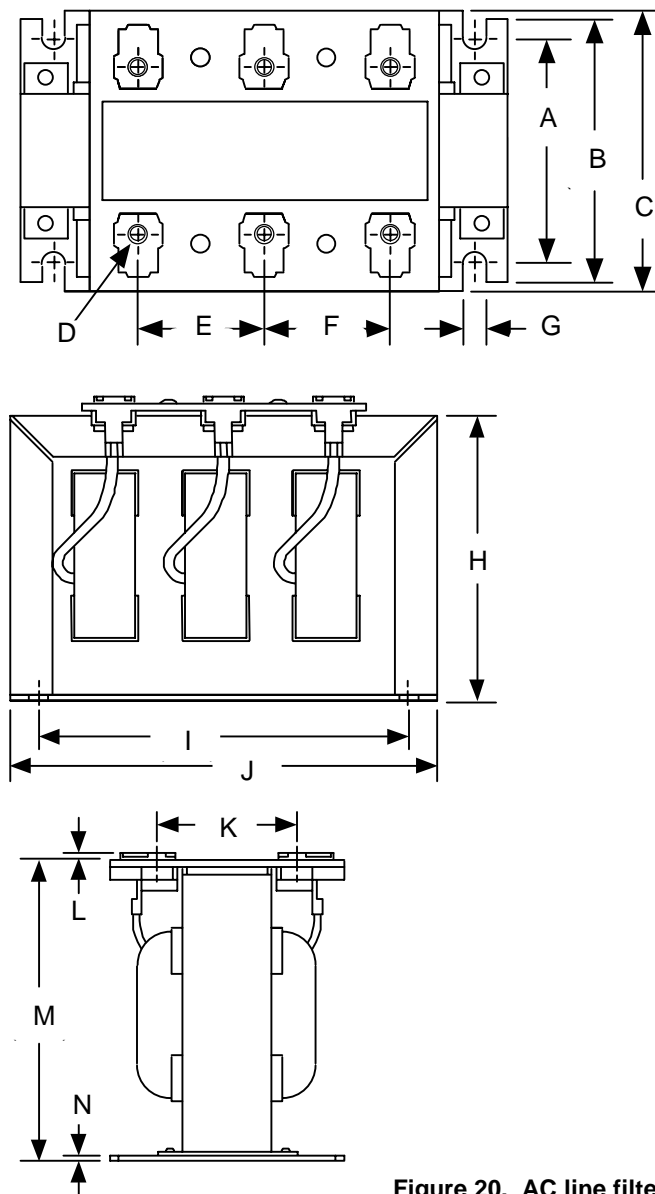

Dim.	AC LINE FILTER	
	5.4 kW	10.5 kW
A	50 mm (1.97in)	65 (2.56)
B	56 (2.20)	76 (2.99)
C	60 (2.36)	80 (3.15)
D	6-M4 x 0.7 deep	6-M5
E	30 (1.18)	35 (1.38)
F	30 (1.18)	35 (1.38)
G	5 (.197)	5.5 (.217)
H	73.6 (2.89)	98.5 (3.86)
I	95 (3.74)	114 (4.49)
J	110 (4.33)	126 (4.96)
K	35 (1.38)	63 (2.48)
L	1.6 (.062)	2 (.079)
M	78.5 (3.09)	113 (4.45)
N	1.6 (.062)	2 (.079)

Figure 20. AC line filter dimension drawing

6.3 CIRCUIT BREAKER SELECTION

To provide proper protection for the amplifier, use a circuit breaker rated at no more than 20 Amps (10A for VDE 1601 compliance for CE marking). Table 15 will help you select the appropriate circuit breaker for your motion application.

Table 15. Currents drawn at continuous rated output

Motor	Input Current 3-phase*
α6/3000	6 A (rms)
α12/3000	11 A (rms)
α22/2000	15 A (rms)
α30/3000	21 A (rms)
α40/2000	29 A (rms)

NOTE

When multiple amplifiers are connected to a single circuit breaker, select a breaker by multiplying the sum of the currents listed in Table 15 by 0.6.*

During rapid motor acceleration, a current that is three times the continuous rating flows. Select a circuit breaker that does not trip when a current that is three times the continuous rating flows for two seconds.

*This factor attempts to compensate for applications where all axes are not demanding full power at the same time. For applications where all axes are running continuously or with high duty cycles, this factor must be increased to 1.

6.4 ELECTROMAGNETIC CONTACTOR (MCC) RATING

To prepare for incoming AC power, you must also select and install an appropriate electromagnetic contactor (MCC), based on the peak currents for the motors in your system. A contactor is typically required on systems approved to display the CE marking (Machinery Directive). When multiple amplifiers are connected to a single circuit breaker, select a breaker based on the sum of the currents in Table 15.

6.5 INCOMING AC POWER

The α SVU Series servo amplifiers require a three-phase AC input for main bus power and a single-phase AC input for control power. Two terminals of the three-phase input (L1 and L2) are connected with the terminals for the single-phase input by jumper bars on terminal board T1 at the factory. If you want to separate the two power supplies, remove the jumper bars. The power requirements for these supplies are shown below:

Table 16. AC and control power

Specification	Description
Voltage: 3-phase	200 VAC to 240 VAC
Frequency	50 Hz, 60Hz ±2 Hz
Voltage fluctuation during acceleration/deceleration	7% or less

Table 17. Control power current

Amplifier Model	Control Power Current
α SVU1-80	150 mA
α SVU1-130	300 mA

6.5.1 AC Power Ratings

The power supply rating required when using multiple servo motors can be determined by summing the requirements of the individual motors.

The power supply ratings listed in Table 18 are sufficient as continuous ratings. Note, however, that servo motor acceleration causes a current to momentarily flow that is approximately three times the continuous flow rating.

When the power is turned on, a surge current of about 37A (when 264VAC is applied) flows for 20 msec.

Table 18. Three-phase power supply ratings

Motor	Power Supply Rating	Current @ 230 VAC
α6/3000	2.2 kVA	6 A
α12/3000	4.3 kVA	11 A
α22/2000	5.9 kVA	15 A
α30/3000	8.2 kVA	21 A
α40/2000 with fan	11.3 kVA	29 A

6.6 DISCHARGING REGENERATIVE ENERGY

Regenerative energy is normally created in applications with a high load inertia or frequent acceleration and deceleration. When decelerating a load, the stored kinetic energy of the load causes generator action in the motor causing energy to be returned to the α Series amplifier.

The α SVU amplifiers have a regenerative discharge resistor built in to dissipate this energy. For light loads, low acceleration rates, or low speed machines, the amplifier may be able to handle the regenerated energy. Some applications may require the assistance of a separately mounted external regenerative discharge unit. Vertical axes with no counter balance may generate excessive regenerative energy. These units comply with VDE 0160, European Safety Standards for CE marking.

Three separate regenerative discharge units are available for the α SVU Series amplifiers:

- 16 Ω, 200 W (A06B-6089-H500) for the SVU1-80 (weight of 2.2 Kg [4.8 lb])
- 16 Ω, 800 W (A06B-6089-H713) for the SVU1-80 (weight of 5 Kg [11 lb])
- 8 Ω, 800 W (A06B-6089-H711) for the SVU1-130 (weight of 5 Kg [11 lb])

Calculations to determine if a separate regenerative discharge unit is required are shown in Section 6.6.1.

If the regenerative discharge unit overheats, a built-in thermostat is tripped, the external overheat alarm is issued, and the motor is stopped. If an external regenerative discharge unit is required, a separate unit must be installed for each amplifier. This component cannot be daisy-chained. The dimensions for these units are shown in Section 6.6.2. Connections for cables K7 and K8 are shown on p. 54 of this document.

6.6.1 Calculating the Average Regenerative Energy

Use the following calculation to determine the average regenerative power that will be released in your application (ambient temperature is assumed not to exceed 55°C). Based on the calculations, a separate regenerative discharge unit may be required. If this is the case, select either the 200 W or 800 W regenerative discharge unit as appropriate for the amplifier model. The watt rating of the selected unit must exceed the average calculated regenerative power.

$$\begin{array}{rcccl}
 \text{Average} & & & & \\
 \text{Amount of} & = & \text{Rotational Power Released} & - & \text{Power} \\
 \text{Regenerative} & & \text{During Deceleration (P}_1\text{)} & & \text{Consumed} \\
 \text{Discharge (W)} & & \text{(STEP 1)} & & \text{through Axis} \\
 & & & & \text{Friction (P}_2\text{)} \\
 & & & & \text{(STEP 2)} \\
 & & & + & \text{Vertical Power} \\
 & & & & \text{Released During} \\
 & & & & \text{Downward} \\
 & & & & \text{Motion (P}_3\text{)} \\
 & & & & \text{(STEP 3)}
 \end{array}$$

STEP 1—Rotational power released during deceleration (P₁)

$$P_1 = (6.19 \times 10^{-4}) \times (J_m + J_L) \times \omega_m^2 / F \text{ watts}$$

where:

F	Deceleration duty (Example: deceleration once per 5 second cycle, F=5)	(sec)
J _m	Motor rotor inertia α6/3000 = 0.0174 α12/3000 = 0.0555 α22/2000 = 0.1041 α30/3000 = 0.1475 α40/2000 = 0.1996	(lb-in-s ²)
J _L	Load inertia converted to motor shaft inertia	(lb-in-s ²)
ω _m	Maximum motor speed at time of deceleration	(rpm)

STEP 2—Power consumed through axis friction (P₂)

$$P_2 = (5.91 \times 10^{-3}) \times t_a \times \omega_m \times T_L / F \text{ Watts}$$

where:

ω _m	Maximum motor speed at time of deceleration	(rpm)
t _a	Worst case/deceleration time (shortest time)	(sec)
T _L	Machine friction torque	(in-lb)
F	Deceleration duty	(sec)

STEP 3—Vertical power released during downward motion (P₃)

(this term applies only for vertical axis operation)

$$P_3 = (1.182 \times 10^{-2}) \times T_h \times \omega_m \times \frac{D}{100} \text{ Watts}$$

where:

ω _m	Motor speed during rapid traverse	(rpm)
T _h	Upward supporting torque applied by the motor during downward motion	(sec)
D	Duty cycle of downward operation (Note: The maximum value of D is 50%)	(%)

STEP 4—Determine if a separate regenerative discharge unit is required

When the average regenerative power produced never exceeds the values indicated in Table 19, a separate regenerative discharge unit is **NOT** required:

$$\text{Average Regenerative Power} = P_1 - P_2 + P_3$$

Table 19. Maximum allowable regenerative energy for amplifiers

Amplifier	Max. Allowable Regen. Power	Used with Motors
αSVU1-80	100 watts	α6/3000, α12/3000, α22/2000
αSVU1-130	400 watts	α30/3000, α40/2000 w/fan

If the average regenerative power exceeds the value for the amplifier, only then is a separate regenerative discharge unit required. Select a unit from Table 20 that exceeds the calculated power value.

Table 20. Regenerative discharge capacity

Amplifier Model	Unit	Catalog #	No Air Flow	Air Velocity 2m/sec	Air Velocity 4m/sec
αSVU1-80	16 Ω, 200 W	A06B-6089-H500	200 W (as shipped)	400 W*	600 W*
αSVU1-130	8 Ω, 800 W	A06B-6089-H711	Forced cooling fan is installed		800 W
αSVU1-80	16 Ω, 800 W	A06B-6089-H713	Forced cooling fan is installed		800 W

*GE Fanuc does not supply a cooling fan for this unit. These values are supplied for reference only (customer-supplied fan).

EXAMPLE:

Assume a vertical axis using an α12/3000 motor ($J_m = 0.0555 \text{ lb-in-s}^2$) that decelerates once every 4 seconds ($F = 4$) for 0.10 seconds (t_a) from a maximum speed of 2500 rpm (ω_m). The machine load inertia reflected to the motor shaft (J_L) is 0.05 lb-in-s^2 . The torque (max) required to support the load during a downward move (T_h) is 100 in-lb, and the downward motion is 20% of the cycle (D). Axis friction (T_L) is 35 in-lb.

STEP 1:

$$P_1 = \text{Rotational Power} = (6.19 \times 10^{-4}) \times (0.0555 + 0.05) \times 2000^2/4 = 65.3 \text{ Watts}$$

STEP 2:

$$P_2 = \text{Friction Power} = (5.91 \times 10^{-3}) \times 0.10 \times 2000 \times 35/4 = 10.3 \text{ Watts}$$

STEP 3:

$$P_3 = \text{Vertical Power} = (1.182 \times 10^{-2}) \times 100 \times 2000 \times \frac{20}{100} = 472.8 \text{ Watts}$$

STEP 4:

$$\begin{aligned}\text{Average Power} &= P_1 - P_2 + P_3 \\ &= 65.3 - 10.3 + 472.8 \\ &= 527.8 \text{ Watts}\end{aligned}$$

(Note the large value associated with the non-counterbalanced vertical load)

Since this value is larger than the 100 W internal capacity of the α SVU1-80 amplifier used with this motor, a separate regenerative discharge unit is required. The A06B-6089-H713 unit is adequate since its 800 W rating exceeds the 539.1 W average for the application. With a customer-supplied fan with at least a 4 m/sec flow rate, the A06B-6089-H500 unit could also be used.

6.6.2 Regenerative discharge unit dimensions

The separate regenerative discharge units are designed with a rear-mounted heat sink that extends through a hole in the mounting plate. This design eliminates most of the heat inside the control cabinet. This section contains the dimensions for the units, and Section 6.6.3 shows the necessary panel cutouts to properly mount the units in an enclosure.

A06B-6089-H500 (200 W) for the α SVU1-80

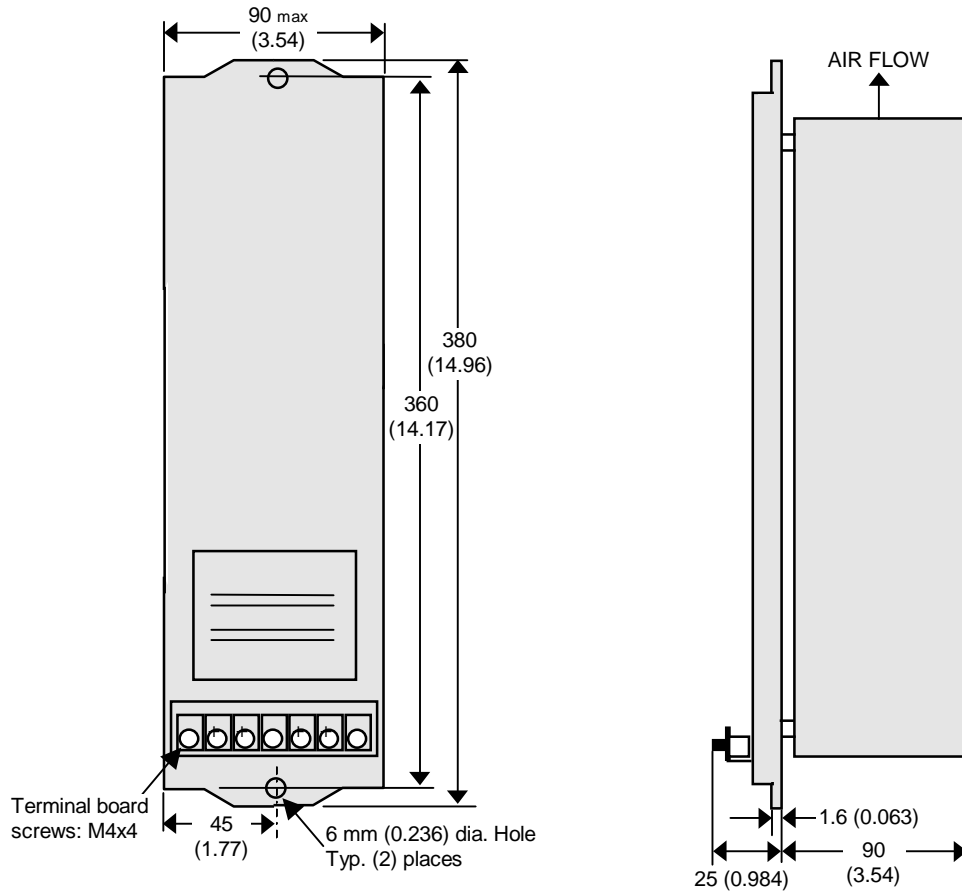

Figure 21. 200 W Regenerative discharge unit (A06B-6089-H500), front, side, and end views

A06B-6089-H711 (800 W) for the α SVU1-130 and A06B-6089-H713 (800W) for the α SVU1-80

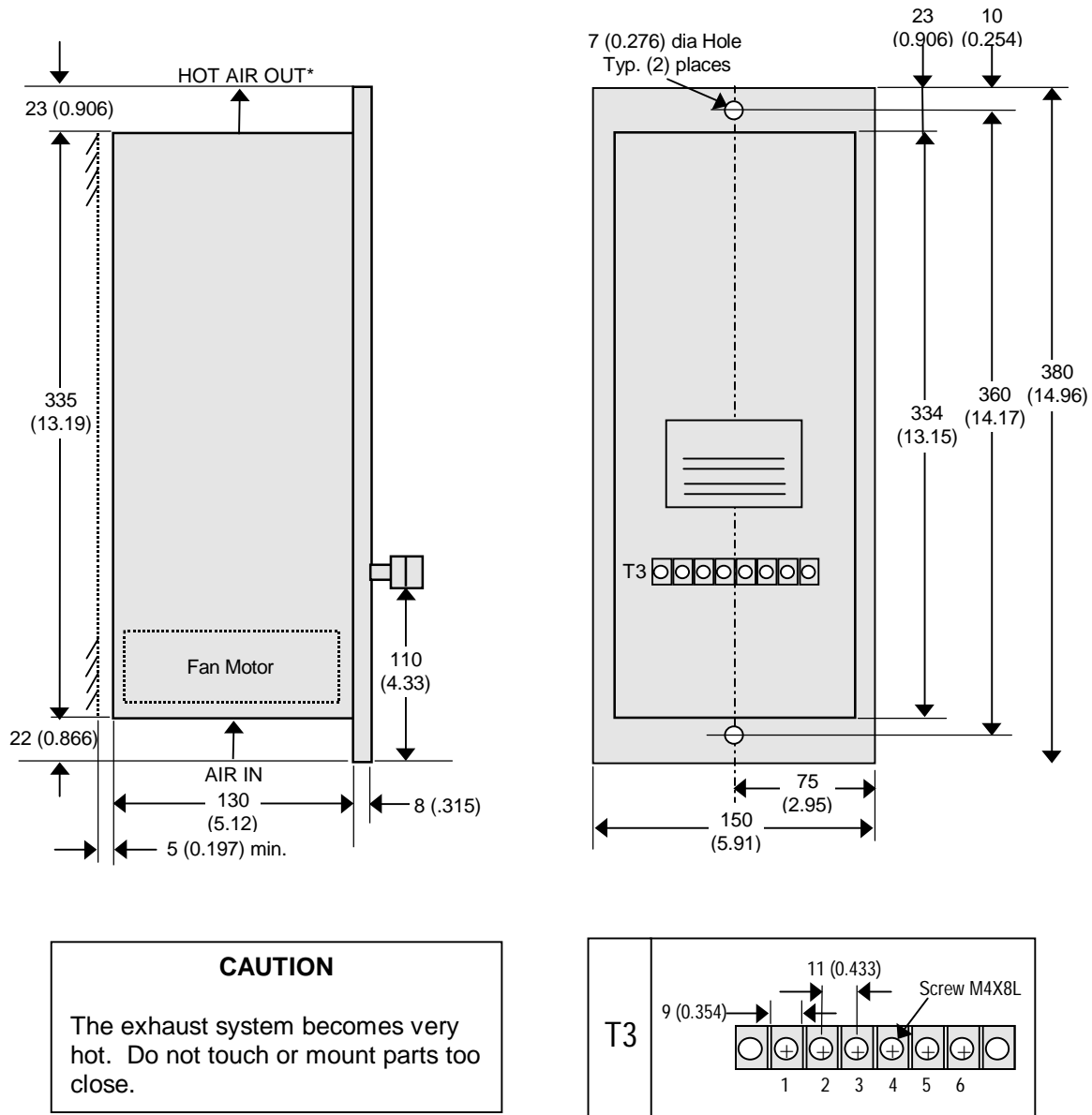

Figure 22. 800 W Regenerative discharge unit (A06B-6089-H711, A06B-6089-H713), front, side, and end views and T3 terminal detail

6.6.3 Regenerative discharge unit panel cutout dimensions

The panel cutouts necessary to mount the separate regenerative discharge units are shown below.

A06B-6089-H500 (200 W) for the α SVU1-80

A06B-6089-H711 (800 W) for the α SVU1-130

A06B-6089-H713 (800 W) for the α SVU1-80

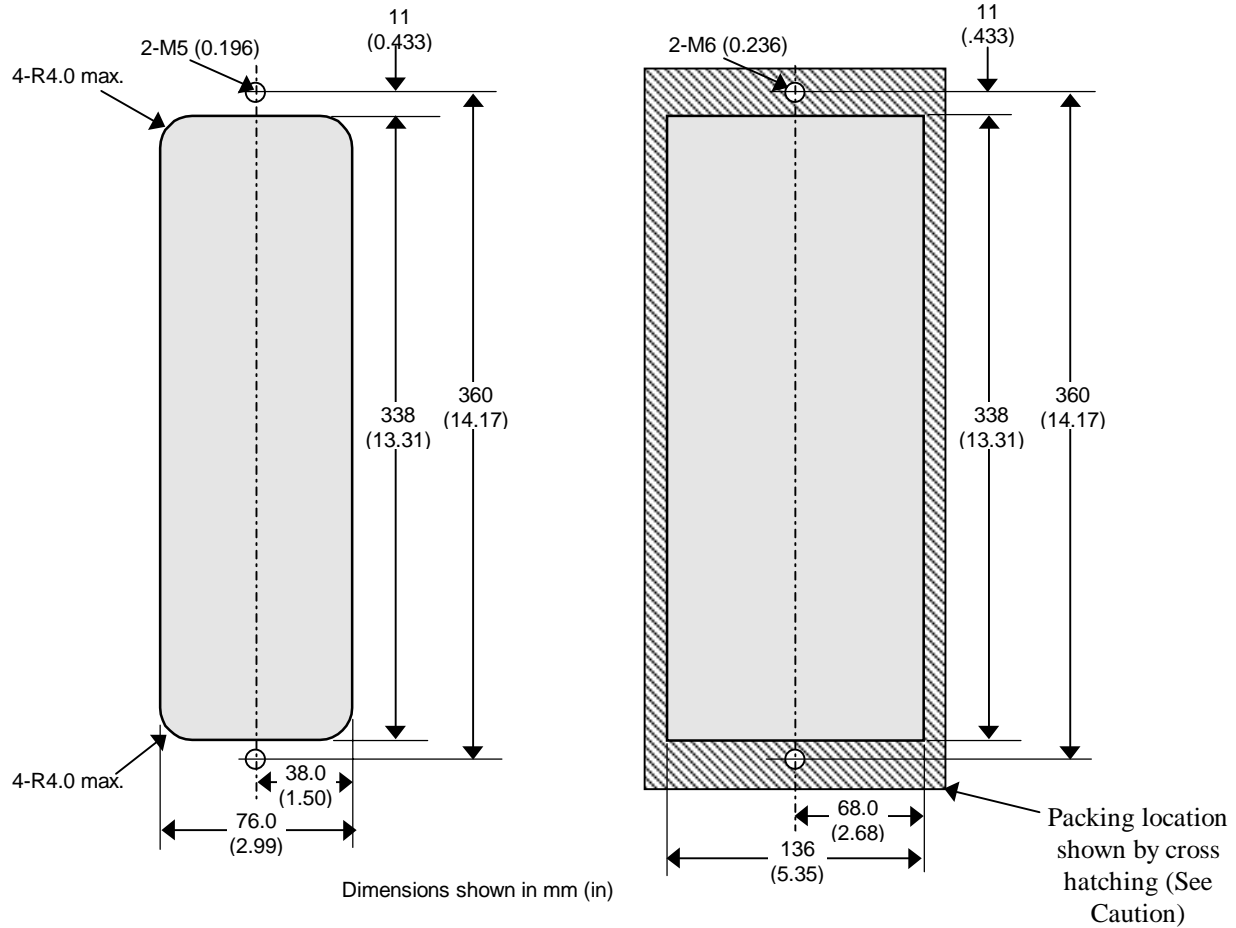

CAUTION:
Attach packing (acrylonitrile-butadiene rubber or soft NBR) around the cutout to keep out oil and dust.

Figure 23. Regenerative discharge unit panel cutout dimensions

Section 7: α Servo System Connection

7.1 α SVU1 AMPLIFIER CONNECTIONS

Power terminations are connected to the αSVU amplifiers on Terminal Board T1 located on the front of the amplifier. The terminals are shielded by a hinged cover that includes a convenient label indicating the terminal designations, as shown in Figure 24. Terminals are M4 screws and will accept stripped wire, spring spade, or ring terminals.

α SVU1-80
(A06B-6089-H105)

α SVU1-130
(A06B-6089-H106)

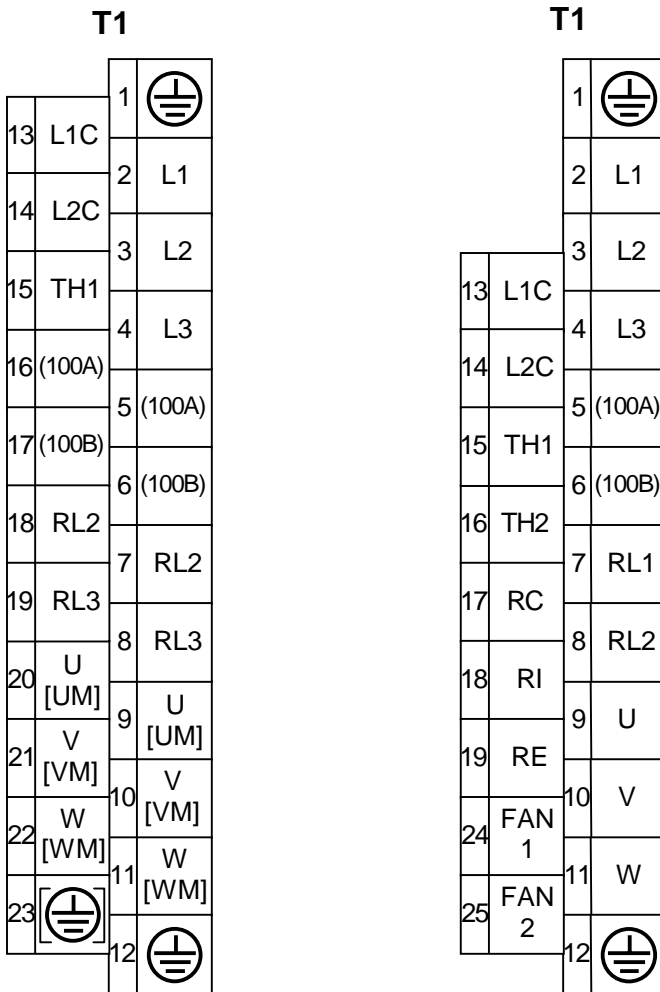

NOTE

5 and 6 on terminal board T1 are not used with the α SVU1 Series.

Figure 24. αSVU amplifier terminal designations

Signal and control cables are interfaced to the amplifiers using connectors on the bottom of the unit. Location and designation of each connector is shown in Figure 25.

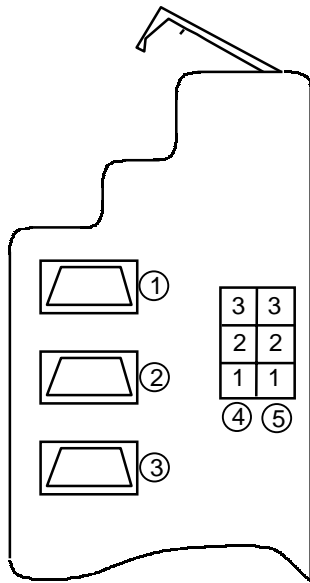

#	Connector Description	Connector Label	Remarks	See Section 7.4
①	Connector for GE Fanuc Motion Controller or CNC Interface	JS1B	N/A	K1 cable
②	Connector for Serial Encoder	JF1	N/A	K2 cable
③	Connector for Serial Encoder Battery	JA4	N/A	K9 cable
④	Connector for 24V power supply (connector keyed for Y position)	CX3	pin 1 pin 3	K10 cable
⑤	Connector for E-Stop input signal (connector keyed for X position)	CX4	pin 2; ESP pin 3; 24V	K5 cable

Figure 25. Bottom view of αSVU amplifier

7.2 α SYSTEM CONNECTIONS

When planning your system, it is important to determine how the different parts of the system connect together. Cable reference numbers K1 through K15 on the α Servo Connection Diagram in Section 7.3 and in Table 22 indicate the required and optional system connections.

The α Series motor and amplifier connectors required for the system are available from GE Fanuc.

GE Fanuc supplies connectors in order to allow you to manufacture cables to the specific length required by your system design. GE Fanuc does offer finished cables as options for many connections. See the Cable Connections chart that follows for more information.

An external contactor (MCC) connector (A06B-6089-K201) and E-Stop connector (A02B-0120-K321) are shipped with each α Series servo amplifier package.

Optional As are also available for the various and feedback cables.

Table 21. Available motor cable connectors for α Servo systems

Part Number	Description
44A730464-G18	Motor Power Connector Kit, α6/3000
44A730464-G20	Motor Power Connector Kit, α12/3000 and α22/2000
44A730464-G21	Motor Power Connector Kit, α30/3000 and α40/2000
A06B-6050-K115	Motor Encoder Connector Kit, α 6/3000
44A730464-G24	Motor Encoder Connector Kit, α12/3000, α22/2000, α30/3000, and α40/2000
44A730464-G26	Motor Brake Connector Kit, all α Series motors

α and β Series Servo Product Specifications Guide

Table 22. Cable Connections

Ref.	Connects	Prefinished Cable Part Number	Connection Type	When Required
K1	DSM302 to Amplifier (JS1B)	IC800CBL001 (1m) IC800CBL002 (3m)	Servo Command Signal	always
K1	All Other Controllers to Amplifier (JS1B)	IC800CBL003 (2m)	Servo Command Signal	always
K2	Built in Serial Encoder to Amplifier (JF1)	IC800CBL021 severe duty (14m)	Motor Encoder Feedback	always
K3	AC Power Supply to Amplifier	N/A	3-Phase Servo Power	always
K4	Amplifier to Motor (Prefinished cables include separate cable to connect motor frame ground to customer's earth ground.)	IC800CBL061 (α6/3000) [14m] IC800CBL062 (α12/3000, α22/2000) [14m] IC800CBL063 (α30/3000, α40/2000) [14m]	Motor Power	always
K5	Amplifier E-stop contact (CX4) to machine E-stop contact	N/A	Emergency Stop	always
K6	AC Control Power Supply to Amplifier	N/A	Amplifier Control Power	always
K7	Amplifier to Regenerative Discharge Unit	N/A	Separate Regenerative Discharge Unit	in some cases ¹
K8	Regenerative Discharge Unit Over Temperature Switch to Amplifier	N/A	Separate Regenerative Discharge Unit	in some cases ¹
K9	Amplifier (JA4) to Encoder Backup Battery Unit	44C741863-001	Absolute Encoder Battery	with battery option ²
K10	Control to MCC Coil Connector (CX3) on Amplifier	N/A	Emergency Stop/Power Enable	control-dependent; consult your control documentation
K11	Amplifier to Regenerative Discharge Unit Cooling Fan	N/A	Separate Regenerative Discharge Unit Fan Supply Cable	in some cases ¹
K12	90 VDC Brake Power Supply to Motor Brake	44C742238-004 (14m)	Motor Brake Power	with brake option
K13	Motor Cooling Fan to Fan Power Supply	44C742238-004 (14m)	Motor Fan Power	α40/2000 with fan only

¹ See the Discharging Regenerative Energy section in Section 6.6

² Prefinished cable is provided as a part of a battery pack option

7.3 α SERIES SERVO CONNECTION DIAGRAM

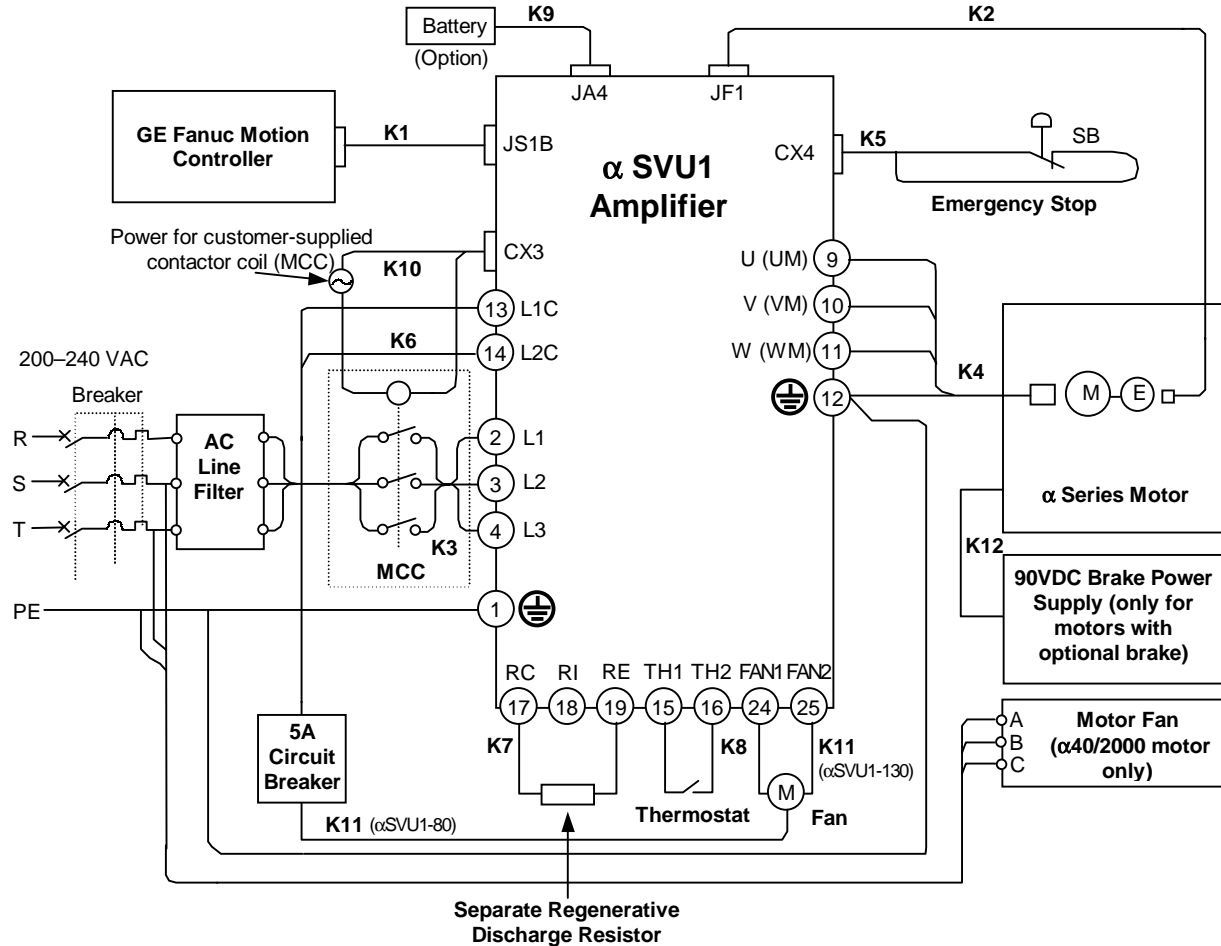

NOTES

- An AC line filter is recommended (unless an isolation transformer is provided) to reduce the effect of harmonic noises to the power supply. Two or more αSVU amplifiers can be connected to one AC line filter if its power capacity is not exceeded.
- RC and RI were connected to each other through a jumper bar at the factory. If a separate regenerative discharge unit will be used, the jumper bar must be removed.
- TH1 and TH2 were connected to each other through a jumper bar at the factory. Remove the jumper bar and connect these terminals to the separate regenerative discharge unit and resistor thermal switch.
- Only the αSVU1-130 (A06B-6089-H106) has FAN1 and FAN2 terminals. Connect the terminals to the fan motor (K11 cable) of the separate regenerative discharge unit (other than the A06B-6089-H106). If a fan is to be used with the αSVU1-80 the fan power should be connected to L1C and L2C through a 5-amp circuit breaker as shown.
- For CE Mark applications, an MCC that complies with European standards should be selected. The user should determine details of the use of the MCC.

7.4 CONNECTION DETAILS

K1—Servo Command Signal Cable (α6/3000, α12/3000, α22/2000, α30/3000, α40/2000)

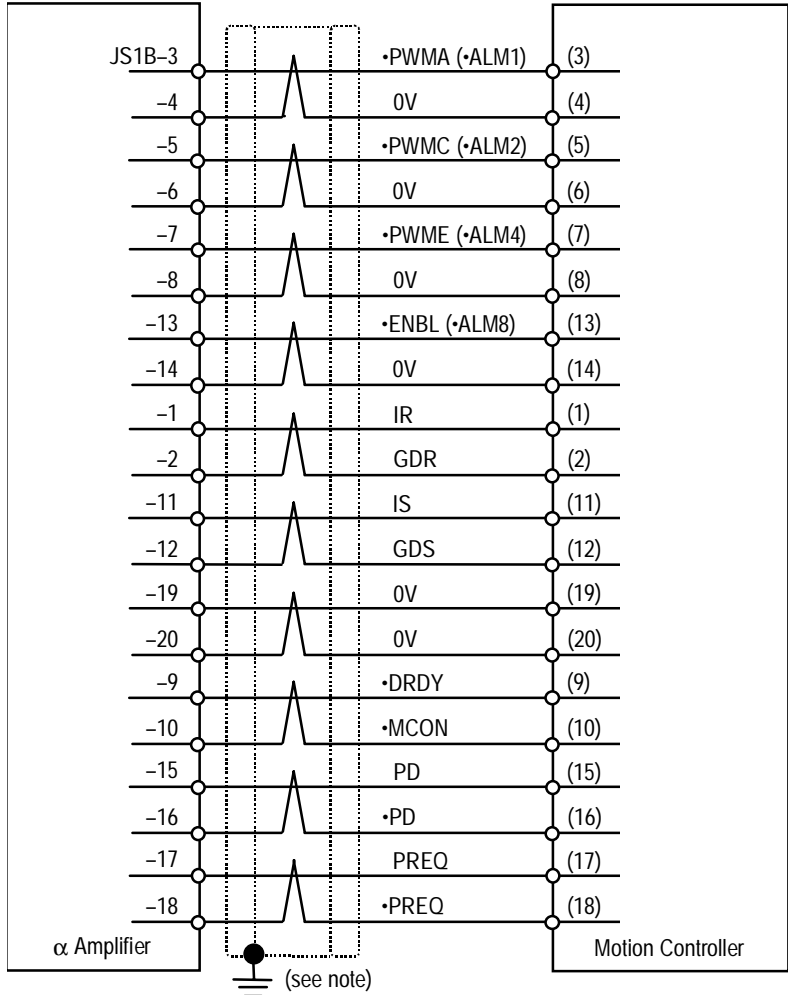

NOTES

The servo command cables for the DSM300 Series controller (IC800CBL001 and IC800CBL002) must be purchased from GE Fanuc. Proper tooling is required to assemble the connectors. For custom length cables, contact your GE Fanuc Distributor or GE Fanuc Sales Engineer.

Grounding the cable shield using the grounding bar (44B295864-001) and cable grounding clamp (A99L-0035-0001) will provide greater noise immunity.

- Wire: 0.08mm² twisted pair group shielded cable (10 pairs). The following wire is recommended for the K1 cable: 28 AWG x 10 pairs (20 conductors).

α and β Series Servo Product Specifications Guide

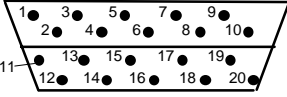
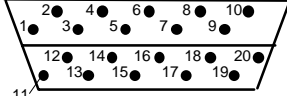
<i>Cable (K1)</i>	<i>GE Fanuc Part No.</i>	<i>Connector Manufacturer</i>
DSM300 Controller to Servo Amplifier (JS1B)	IC800CBL001 (1 meter) IC800CBL002 (3 meter)	Cable must be purchased from GE Fanuc (connectors not sold separately)*
GE Fanuc controller other than DSM302 to Servo Amplifier (JS1B)	IC800CBL003 (2 meter)	<p>Hirose Electric Co., Ltd.</p>  <p>Honda Tsushin Kogyo Co., Ltd. (PCR-E20FA)</p>  <p><i>Connectors viewed from back (solder/crimp side).</i></p>

***NOTE:** DSM302 cables cannot be customer-manufactured and uses a 36-pin connector on its end. The DSM302 module requires IC693ACC355 Axis Terminal Board and either IC693CBL324 (1 meter) or IC693CBL325 (3 meter) Terminal Board Cable to access axis I/O such as Home Switch Input, Over Travel Inputs, or Strobe (registration) Inputs.

K2—Motor Encoder Feedback Cable (α6/3000, α12/3000, α22/2000, α30/3000, α40/2000)

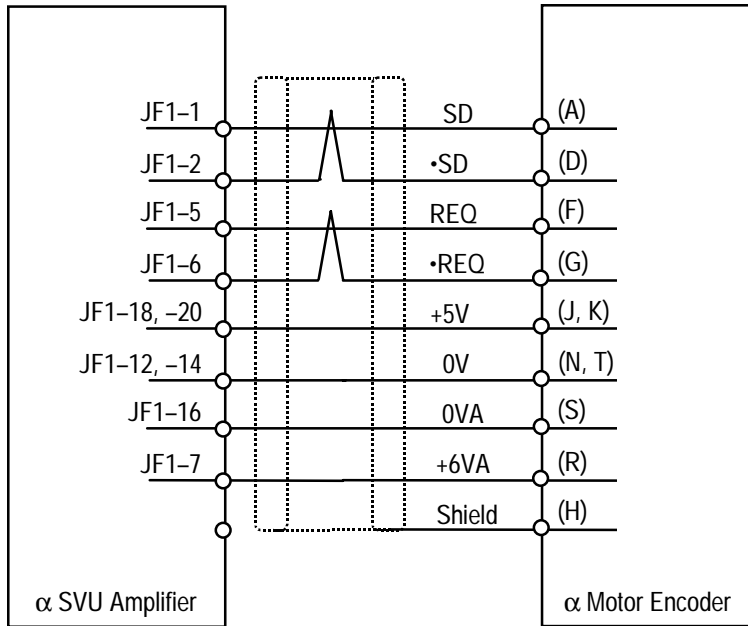

- Prefinished 14m Cable, Part number: IC800CBL021 (severe duty)
- Wire: for +5V, 0V use two parallel conductors of 0.5mm² (20 AWG) or larger when the wire length does not exceed 14m. When the wire length exceeds 14m, wire gauge must be increased to ensure that the sum of the electrical resistance of 0V and 5V circuit does not exceed 0.5 ohms. For 6VA, 0VA use 0.5mm² (20 AWG) or larger; for SD, •SD, REQ, •REQ use 0.18mm² (24 AWG) or larger twisted pair with 60% braid shield.

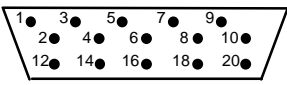
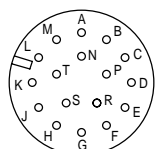
Connector	GE Fanuc Part No.	Manufacturer
Servo Amplifier (JF1)	A02B-0120-K303	Hirose Electric Co., Ltd. (F140-2015S) [connector cover: FI-20-CV]  Connector viewed from back (solder/crimp side).
Servo Motor Encoder	44A730464-G24 (CE EXT GND pin type)	Hirose Electric Co., Ltd. (MS3106A 20-29SW, straight) (MS3108B 20-29SW, elbow) 

K3—Three-Phase Servo Power Cable

For a power supply voltage of 200–240 VAC 50/60 Hz

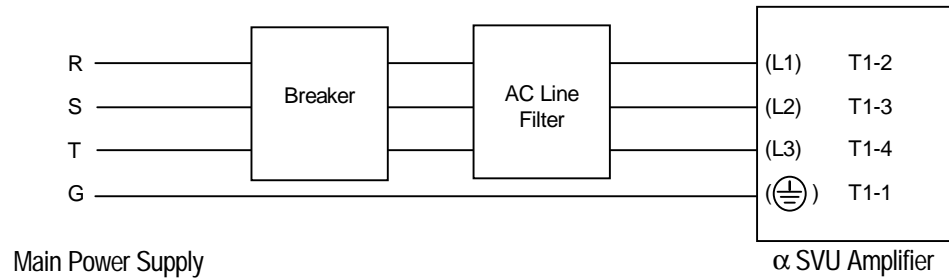

- For αSVU1-80, use 600 V, 4-conductors (JIS C 3312) of 3.5mm² (12 AWG) or larger, heat-resistant vinyl cable (nonflammable polyflex cable with a max. conductor temperature of 105° C) of 3.5mm² (12 AWG) or more.
- For αSVU1-130, use use 600 V, 4-conductors (JIS C 3312) of 5.5mm² (10 AWG) or larger.
- Use M4 terminal board screws on α SVU amplifier

K4—Motor Power Cable (α6/3000)

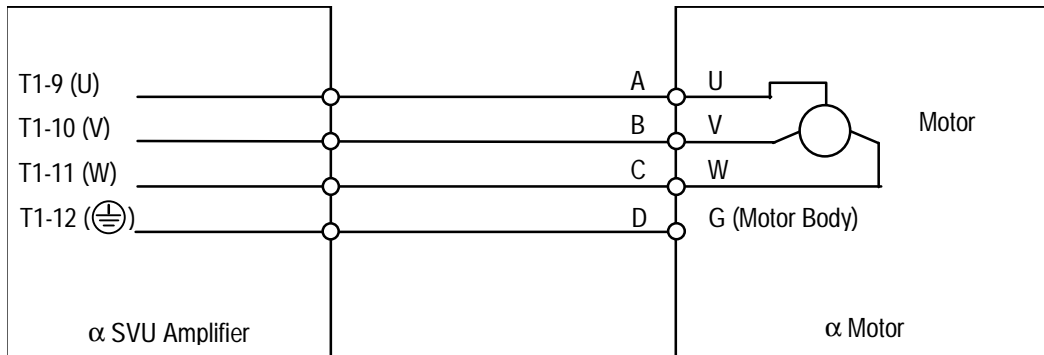

- Prefinished 14m Cable, Part number: IC800CBL061 (severe duty)
- Wire: 4-conductor, 12 AWG, Type S0 power cord, PUR (polyurethane) jacket

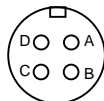
Connector	Part No.	Maker
Servo Amplifier T1 Terminal Board	N/A (M4 Spring Spade)	N/A
Servo Motor	44A730464-G20 (CE EXT GND pin)	DDK CE Series (CE02-6A22-22DS) 

K4—Motor Power Cable (α12/3000, α22/2000)

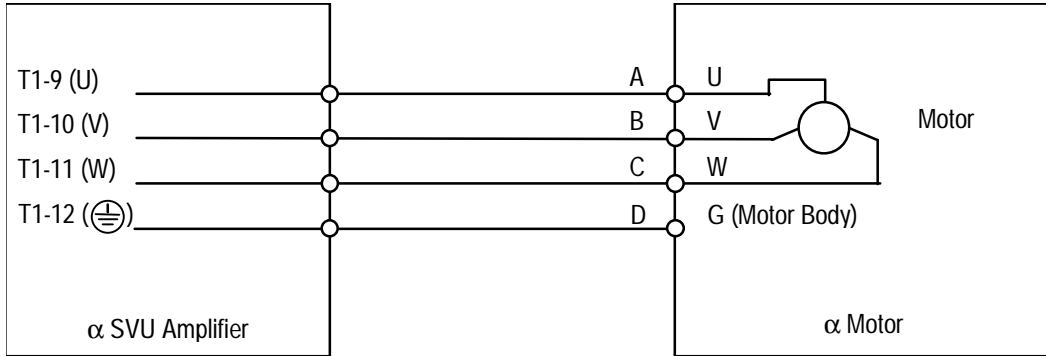

- Prefinished 14m Cable, Part number: IC800CBL061 (severe duty)
- Wire: 4-conductor, 12 AWG, Type S0 power cord, PUR (polyurethane) jacket

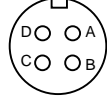
Connector	Part No.	Maker
Servo Amplifier T1 Terminal Board	N/A (M4 Spring Spade)	N/A
Servo Motor	44A730464-G20 (CE EXT GND pin)	DDK CE Series (CE02-6A22-22DS) 

K4—Motor Power Cable (α30/3000, α40/2000)

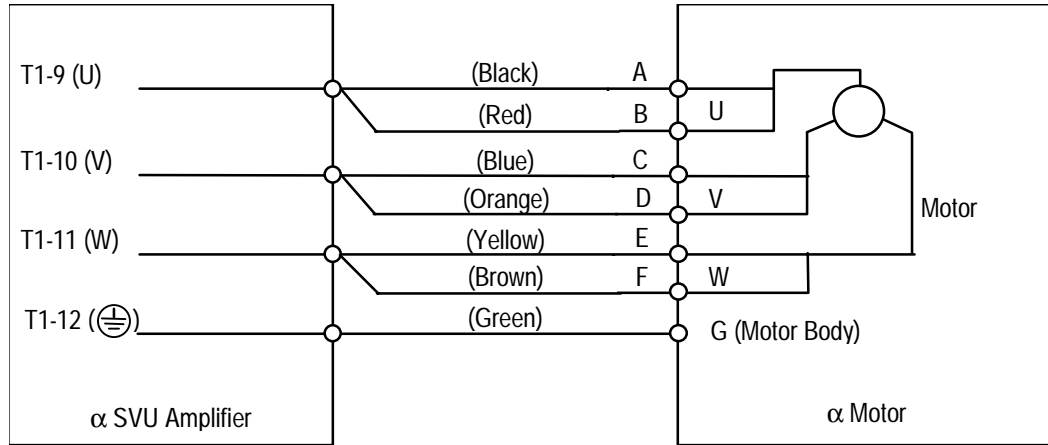

- Prefinished 14m Cable, Part number: IC800CBL063 (severe duty)
- Wire: 7-conductor, 12 AWG, Type SO power cord, PUR (polyurethane) jacket

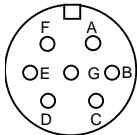
Connector	Part No.	Maker
Servo Amplifier T1 Terminal Board	N/A (M4 Spring Spade)	N/A
Servo Motor	44A730464-G20 (CE EXT GND pin)	DDK CE Series (CE02-6A24-10GS) 

K5—Amplifier Emergency Stop Connection

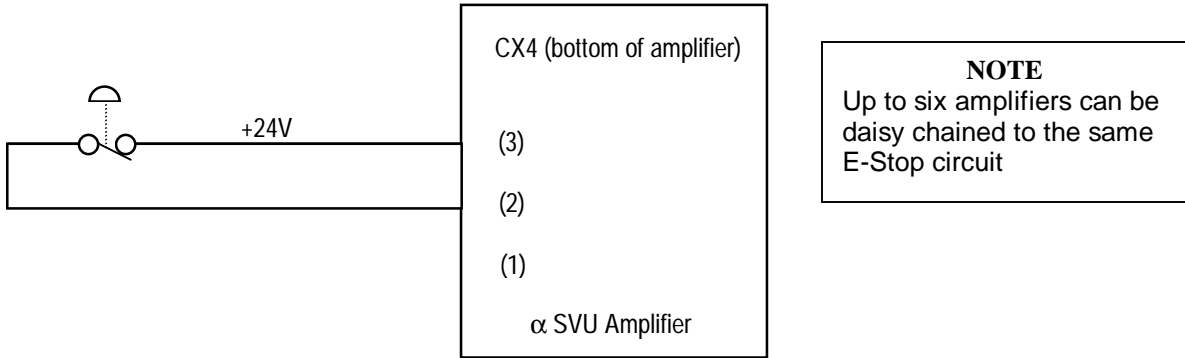

- Wire: 2-conductor 0.75mm² (20 AWG)

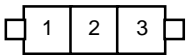
Connector	GE Fanuc Part No.	Manufacturer
Servo Amplifier CX4	A06B-0120-K321 (included with amplifier packages)	AMP Housing: 1-178128-3; Contact: 1-175218-2 (crimp terminal)  Connector viewed from wire insertion side.

K6—Amplifier Control Power Connection

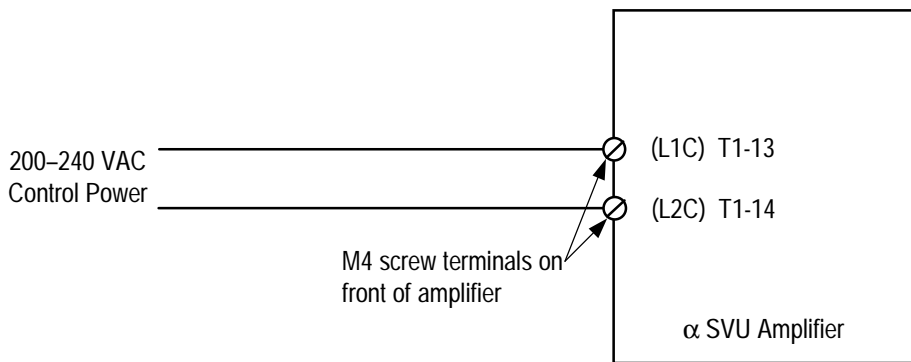

- Wire: 300V, 2-conductor 1.25mm² (16 AWG) or larger

K7—Separate Regenerative Discharge Unit Power Cable
 (α6/3000, α12/3000, α22/2000, α30/3000, α40/2000)

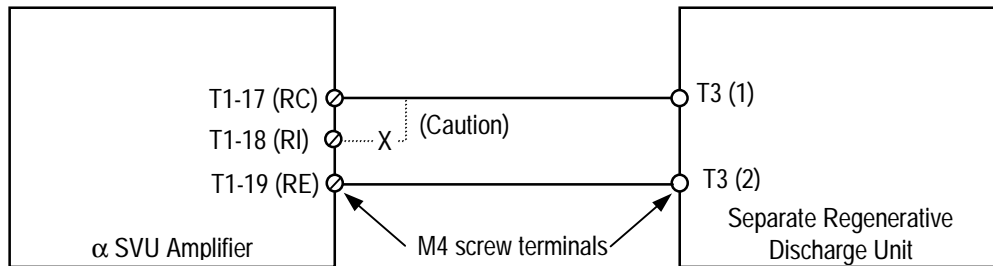

CAUTION

When a separate regenerative discharge unit is connected, remove the factory-installed shorting bar between terminals T1-17 (RC) and T1-18 (RI).

- Wire: 600 V, 2-conductor, 2.0mm² (14 AWG) or larger

K8—Separate Regenerative Discharge Unit Thermal Protection Cable
 (α6/3000, α12/3000, α22/2000, α30/3000, α40/2000)

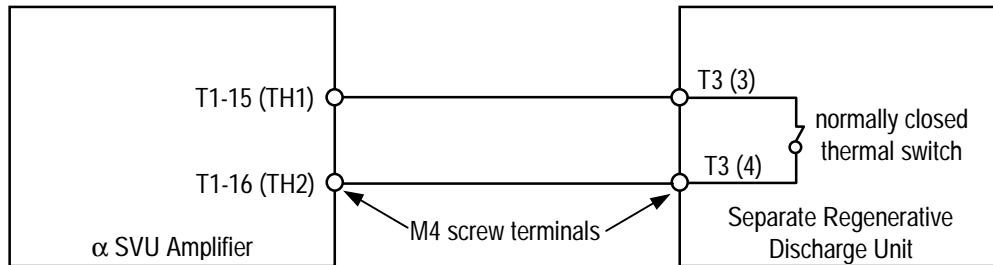

CAUTION

When a separate regenerative discharge unit is connected, the DIP switches on the front of the amplifier must be set for the proper unit. See Section 5.7 for more information.

- Wire: 600 V, 2-conductor, 0.75mm² (18 AWG) or larger

K9—Optional Absolute Encoder Battery Cable (α6/3000, α12/3000, α22/2000, α30/3000, α40/2000)

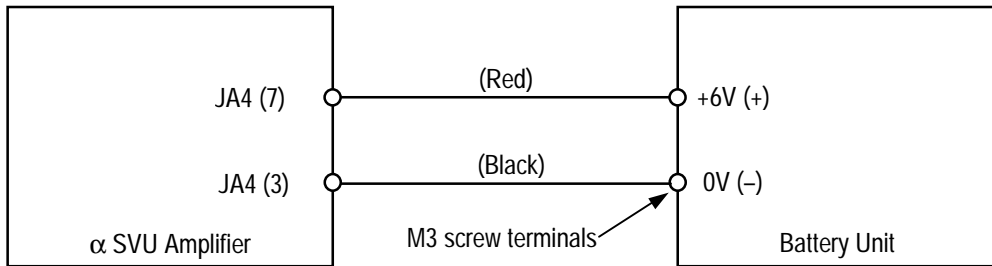

- Prefinished 2m Cable: 44C741863-001 (supplied as a part of α SVU Series Battery Backup Kit IC800ABK001)
- Wire: 2-conductor, 0.75mm² (20 AWG)

Cable	GE Fanuc Part No.	Connector Manufacturer
Servo Amplifier JA4	A02B-0120-K301	<p>Hirose Electric Co., Ltd.</p> <p>Honda Tsushin Kogyo Co., Ltd. (PCR-E20FA)</p> <p><i>Connectors viewed from back (solder/crimp side).</i></p>

K10—Emergency Stop/Power Enable Cable
 (α6/3000, α12/3000, α22/2000, α30/3000, α40/2000)

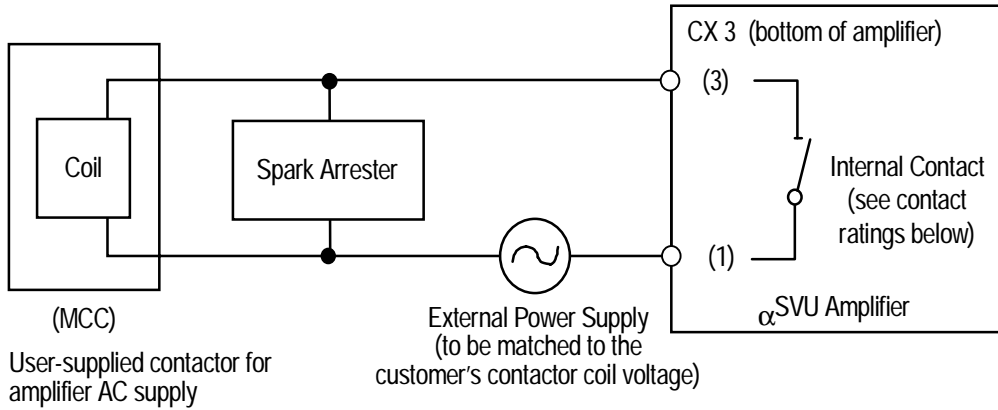

- Wire: 2-conductor, 1.25mm² (16 AWG) or larger

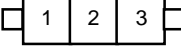
Connector	GE Fanuc Part No.	Manufacturer
Servo Amplifier CX3	A06B-6089-K201 (included with α Series amplifier packages IC800APK080 and IC800 APK130)	AMP Housing: 1-178128-3; Contact: 1-175218-2 (crimp terminal)  Connector viewed from wire insertion end

Contactor Ratings:

Specification of internal contact	Resistor load ($\cos\phi=1$)	Inductance load ($\cos\phi=0.4, L/R=7\text{msec}$)
Rated load	250 VAC, 5A 30VDC, 5A	250 VAC, 2A 30 VDC, 2A
Max. current	5A	5A

K11—Separate Regenerative Discharge Unit Fan Supply Cable (A06B-6089-H711 or A06B-6089-H713)

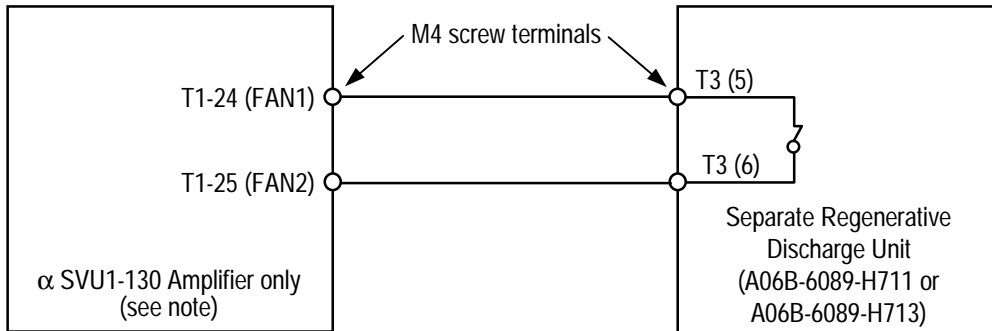

NOTE

Only the α SVU1-130 amplifier has separate fan power supply terminals. When using the A06B-6089-H713 unit with the α SVU1-80 amplifier, connect the fan power to terminals T1-13 (L1C) and T1-14 (L2C) through a 5A circuit breaker.

- Wire: 300 V, 2-conductor, 2.0mm² (16 AWG) or larger

K12—Motor Brake Power Connection

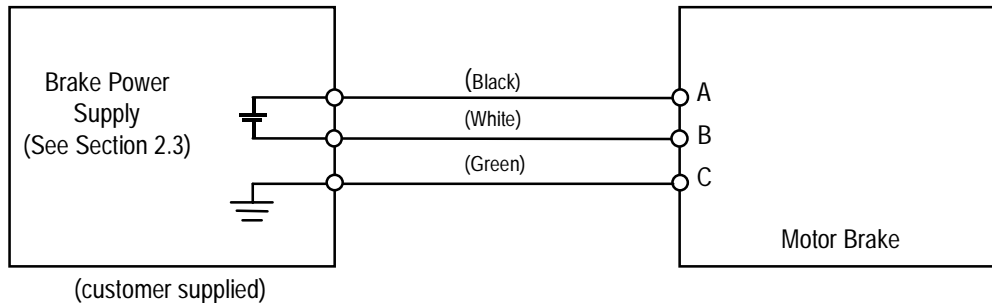

- Prefinished 14m Cable, Part number: 44C742238-004 (severe duty)
- Wire: 330 V, 3-conductor, 20 AWG, 80 °C, PUR (polyurethane) jacket

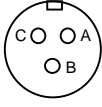
Connector	GE Fanuc Part No.	Manufacturer
Servo Motor Brake	44A730464-G26	AMP 3102A-10SL-3P  Connector viewed from solder side

K13—Cooling Fan Power Connection (α 40/2000)

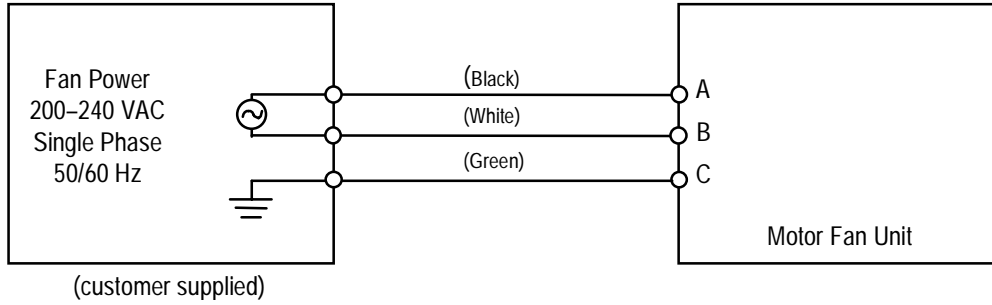

- Prefinished 14m Cable, Part number: 44C742238-004 (severe duty)
- Wire: 330 V, 3-conductor, 20 AWG, 80 °C, PUR (polyurethane) jacket

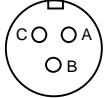
Connector	GE Fanuc Part No.	Manufacturer
Servo Motor Fan	44A730464-G26	AMP 3102A-10SL-3P  Connector viewed from solder side

Fan Voltage/Current Specifications:

Input voltage	Steady-state current	Surge current
200V	Approx. 0.85Arms	Approx. 1.60Arms
230V	Approx. 0.98Arms	Approx. 1.84Arms

Section 8: α SVU Series Protection and Alarm Functions

The Servo Amplifier Unit can detect error conditions and provide alarm information.

The LEDs on the front of the amplifier provide a visual cue to the status of the system by indicating, for example, when the motor and amplifier are ready to function. A built-in, seven-segment LED display indicates when an alarm condition is detected. When an alarm is detected, power is dropped and the motor is stopped by dynamic braking action. Alarm information is displayed as diagnostic data in the GE Fanuc controller. Table 23 details the alarm conditions the α SVU Series Servo Amplifier System can detect. Table 24 shows the LED indication for normal operating mode.

Table 23. α SVU1 Series servo amplifier alarm system

Alarm Type	LED Ind.	Description
Over-voltage alarm (HV)	1	Occurs if the DC voltage of the main circuit power supply is abnormally high.
Low control power voltage alarm (LV)	2	Occurs if the control power voltage is abnormally low.
Low DC link voltage alarm (LVDC)	3	Occurs if the DC voltage of the main circuit power supply is abnormally low or if the circuit breaker trips.
Regenerative discharge control circuit failure alarm (DCSW)	4	Occurs if the short-time peak regenerative discharge energy is too high or if the regenerative discharge circuit is abnormal.
Over-regenerative discharge alarm (DCOH)	5	Occurs if the average regenerative discharge energy is too high (too frequent acceleration/deceleration) or the regeneration resistor overheats.
Dynamic brake circuit failure (DBRLY)	7	Occurs if the relay contacts of the dynamic brake fuse together.
Over-current alarm	8	Occurs if an abnormally high current flows through the motor.
IPM alarm	8 _a	The Intelligent Power Module (IPM) has detected an alarm due to over-current, overheating, or a drop in IPM control power voltage.
Circuit breaker	(trips)	The circuit breaker trips if an abnormally high current (exceeding the working current of the circuit breaker) flows through it.

Table 24. α SVU1 Series servo amplifier alarm system

Type	LED Ind.	Description
Amplifier not ready	—	The servo amplifier is not ready to drive the motor.
Amplifier ready	0	The servo amplifier is ready to drive the motor.

This page intentionally left blank.

Part II:

β Servo

System

Section 9: β Servo System Block Diagram

The following block diagram shows the interconnections of a typical β Series servo system:

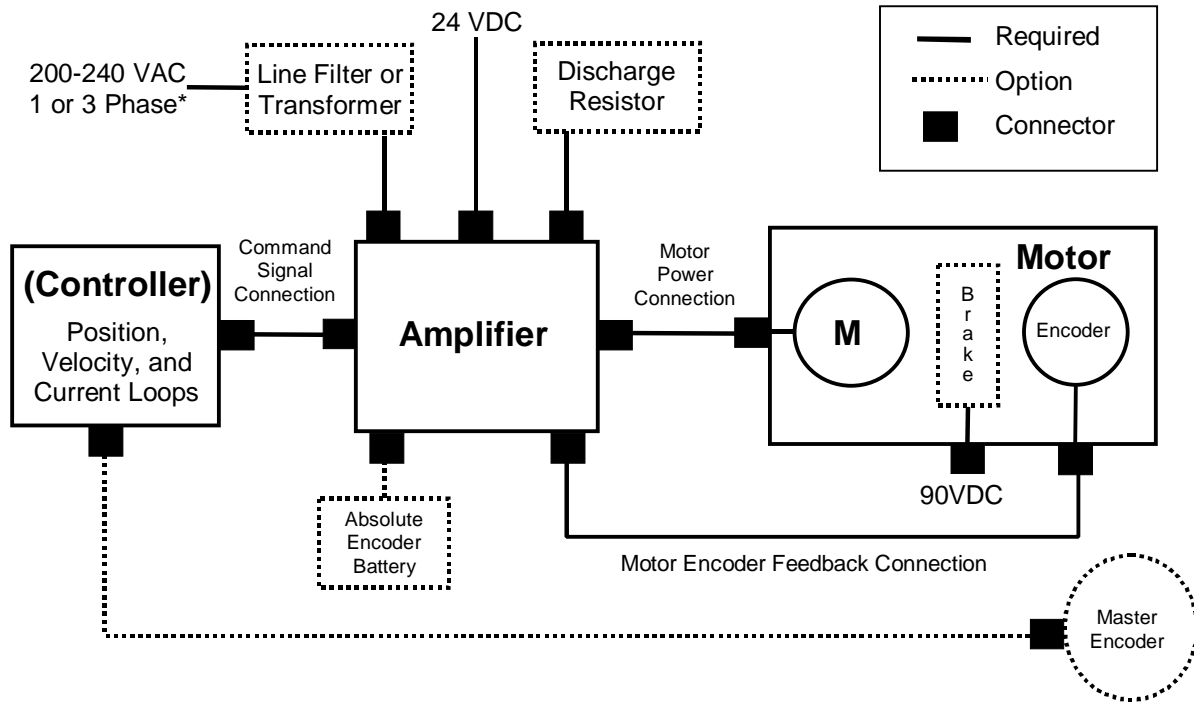

Figure 26. β Series servo block diagram

NOTE

A 24 VDC power supply, circuit breaker, electromagnetic contactor, surge suppresser, and transformer or line filter should be user-installed as part of the system. See β Servo System Package Options in Section 12: and β Servo Installation in Section 13: of this document for more information.

* For single phase input, the lifetime of the amplifier is reduced because of higher input current. For operation of $\beta 6/2000$ or $\alpha C12/2000$ motors at acceleration/deceleration duty cycles greater than 1 cycle/20 seconds, 3-phase input is recommended. The output power of these motors when operated in ambient temperatures greater than 40°C must be derated linearly at 1%/°C above 40°C up to a maximum ambient temperature of 55°C.

Section 10: β Series Servo Product Overview

10.1 β SERIES MOTORS

The β Series servo motors are all digital systems with built-in 32K serial encoders. All β Series motors are available with an optional holding brake. The servo motors must be used with the designated amplifier package and a GE Fanuc motion controller such as the Motion Mate™ DSM 300.

Table 25 provides a summary of the β Series servo motors. See Section 11: for more detailed motor specifications.

Table 25. β Series Servo Motors

Motor	Rated Torque	Power Rating	Required Amplifier Kit	Motor Catalog #
β 0.5/3000	0.5 Nm (5.6 in-lbs) continuous stall torque; 3000 RPM	0.2 kW	12 Amp (IC800BPK012)	Motor Only: A06B-0113-B075#7008 Motor w/ Brake: A06B-0113-B175#7008
β 2/3000	2 Nm (17 in-lbs) continuous stall torque; 3000 RPM	0.5 kW	12 Amp (IC800BPK012)	Motor Only: A06B-0032-B075#7008 Motor w/ Brake: A06B-0032-B175#7008
β 6/2000	6 Nm (53 in-lbs) continuous stall torque; 2000 RPM	0.9 kW	20 Amp (IC800BPK020)	Motor Only: A06B-0034-B075#7008 Motor w/ Brake: A06B-0034-B175#7008
α C12/2000	12 Nm (106 in-lbs) continuous stall torque; 2000 RPM	1.0 kW	20 Amp (IC800BPK020)	Motor Only: A06B-0141-B075#7008 Motor w/ Brake: A06B-0141-B175#7008

10.2 β SERIES MOTOR SPEED-TORQUE CURVES

The curves shown below illustrate the relationship between the speed of the motor and the output torque. The motor can operate continuously at any combination of speed and torque within the prescribed continuous operating zone. The limit of the continuous operating zone is determined with the motor's ambient temperature at 40°C and its drive current as pure sine wave. Actual operation is limited by the current of the servo drive unit.

$\beta 0.5/3000$

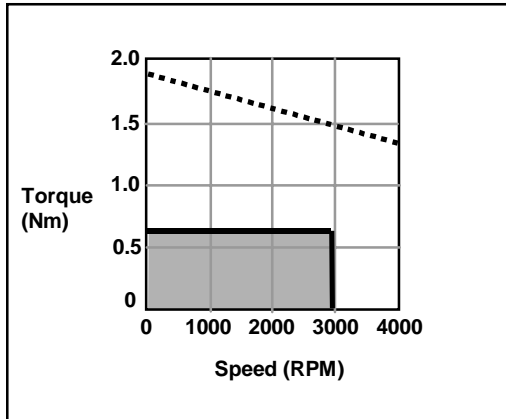

$\beta 2/3000$

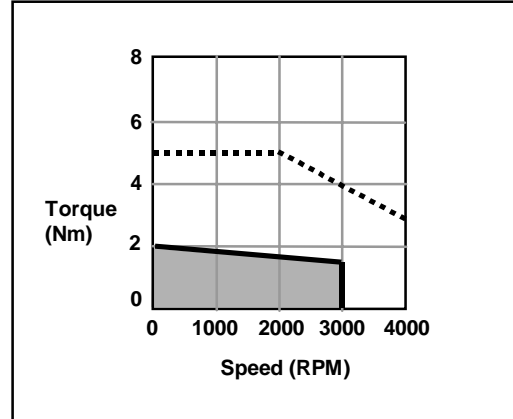

$\beta 6/2000$

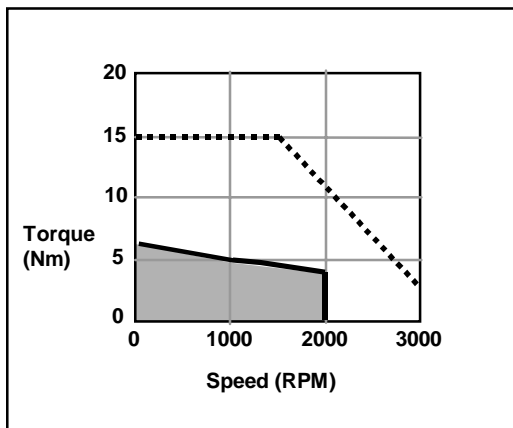

$\alpha C12/2000$

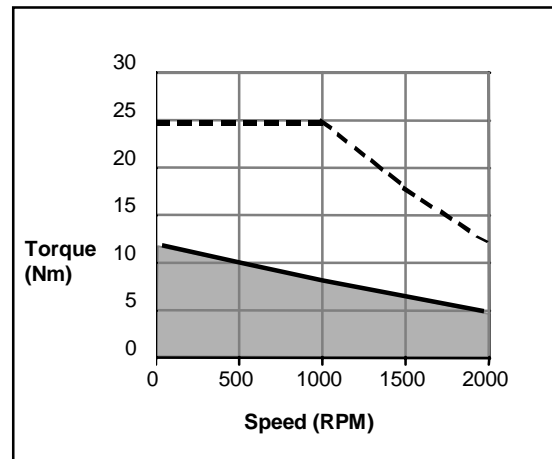

KEY: - - - - = Intermittent operating
 █ = Continuous operating

Figure 27. β Series motor speed-torque curves

10.3 β SERIES MOTOR HOLDING BRAKE

Any of the servo motors can be ordered with a holding brake. The brake is used to prevent movement on horizontal axes or falling along the vertical axis when the servo motor control is turned off.

Brakes are spring-set and electrically released and are designed for holding stationary loads only. Using the holding brake to stop a moving axis may damage the motor or severely reduce its service life.

The specifications of the built-in brakes are listed in Table 26:

Table 26. Brake Specifications

Parameter	SERVO PACKAGE			
	β0.5/3000	β2/3000	β6/2000	αC12/2000
Brake torque	5.75 in-lb 0.65 Nm 6.6 kgf-cm	17.7 in-lb 2 Nm 20 kgf-cm	71 in-lb 8 Nm 82 kgf-cm	310 in-lb 35 Nm 357 kgf-cm
Release Response Time	40 msec	60 msec	80 msec	150 msec
Brake Response Time	20 msec	10 msec	40 msec	20 msec
Supply Voltage and Current	90 VDC (±10%) 0.1 A or less	90 VDC (±10%) 0.3 A or less	90 VDC (±10%) 0.4 A or less	90 VDC (±10%) 0.6 A or less
Weight Increase	Approx. 0.88 lb Approx. 0.4 kg	Approx. 3.3 lb Approx. 1.5 kg	Approx. 5.1 lb Approx. 2.3 kg	Approx. 13.9 lb Approx. 6.3 kg
Inertia Increase	0.00008 in-lb-s ² 0.000009 kg m ² 0.00009 kgf-cm-s ²	0.00017 in-lb-s ² 0.00002 kg m ² 0.0002 kgf-cm-s ²	0.00061 in-lb-s ² 0.00007 kg m ² 0.0007 kgf-cm-s ²	0.0052 in-lb-s ² 0.0006 kg m ² 0.006 kgf-cm-s ²

An example of a typical **user-supplied** brake power supply is shown below:

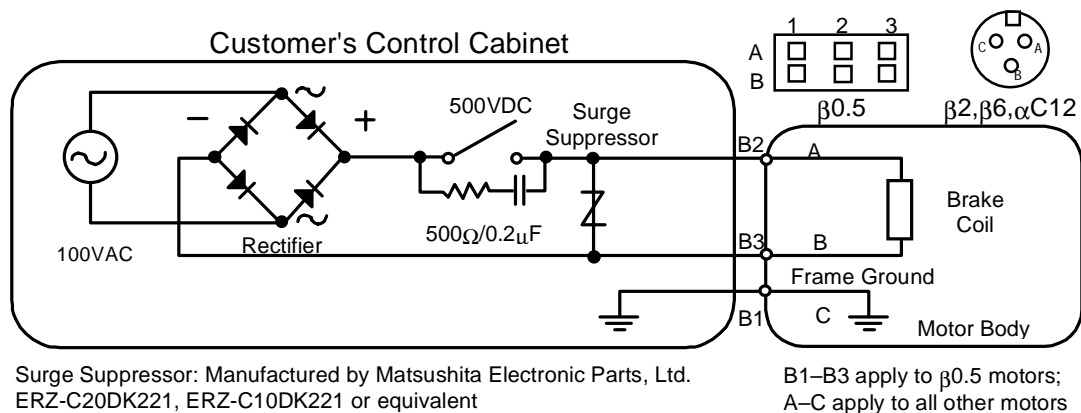

Figure 28. Typical user-supplied brake power supply

NOTE

Use a full-wave rectified 100VAC or 90VDC as a power supply. Do not use a half-wave rectified 200 VAC, which may damage the surge suppressor. Use a rectifier with a dielectric strength of 400V or higher. Connect RC filter as shown in the above drawing to protect the contact of the switch.

10.4 β SERIES SERVO AMPLIFIERS

The following table shows which amplifier model is included in each β Series servo package:

Table 27. β Series Servo Amplifier Models

Motor	Amplifier Model	Amplifier Catalog #	Amplifier Package Catalog #
β 0.5/3000	β 12	A06B-6093-H101	IC800BPK012
β 2/3000	β 12	A06B-6093-H101	IC800BPK012
β 6/2000	β 20	A06B-6093-H102	IC800BPK020
α C12/2000	β 20	A06B-6093-H102	IC800BPK020

As a convenience, amplifiers can also be ordered as a package containing all of the components required to operate the amplifier in a servo system, as detailed in the following table:

Table 28. β Series Servo Amplifier Packages

Description	Package Contents*	Catalog #
12 Amp β Series Amplifier Package	Contains 1 of each of the following: <ul style="list-style-type: none"> • SVU1-12 Amp (A06B-6093-H101) • Fuse (A06B-6073-K250) • Connector Kit (A06B-6093-K301) • E-Stop Connector (A02B-0120-K301) • 100 Watt Discharge Resistor (A06B-6093-H402) 	IC800BPK012
20 Amp β Series Amplifier Package	Contains 1 of each of the following: <ul style="list-style-type: none"> • SVU1-20 Amp (A06B-6093-H102) • Fuse (A06B-6073-K250) • Connector Kit (A06B-6093-K301) • E-Stop Connector (A02B-0120-K301) • 100 Watt Discharge Resistor (A06B-6093-H402) 	IC800BPK020

* If required, amplifier package components can be ordered separately.

Section 11: β Series Servo System Specifications

The β Series Servo system consists of a motor and its corresponding amplifier. GE Fanuc offers several servo systems, which are identified in Table 29 below.

Table 29. Identification of Servo Systems

Parameter (Unit)	SERVO SYSTEM			
	β0.5/3000	β2/3000	β6/2000	αC12/2000
MOTOR				
Rated output power (kW)	0.2	0.5	0.9	1.0
Rated torque at stall (Nm) *	0.6	2	6	12
Rated torque at stall (in-lb) *	5.3	17	53	105
Rated torque at stall (kgf-cm) *	6.1	20	60	122
Rated output speed (RPM)	4000	4000	3000	2000
Rotor inertia (kg m ²)	0.000017	0.00065	0.0039	0.0062
Rotor inertia (in-lb-s ²)	0.00016	0.00581	0.0347	0.0555
Rotor inertia (kg-cm-s ²)	0.00018	0.0067	0.040	0.064
Continuous current at stall A(rms)	2.8	3.2	5.6	5.9
Torque constant (Nm/A [rms]) *	0.23	0.61	1.05	2.04
Torque constant (in-lb/A [rms]) *	2.0	5.4	9.3	18
Torque constant (kgf-cm/A [rms]) *	2.3	6.2	10.7	20.8
Back EMF constant (V/1000 RPM) *	7.9	21.4	37.0	71
Back EMF constant (Vsec/rad) *	0.08	0.20	0.35	0.68
Armature resistance (Ω) *	0.80	1.4	0.85	1.092
Mechanical time constant (s) *	0.0007	0.008	0.009	0.005
Thermal time constant (min)	10	20	40	60
Static friction (Nm)	0.04	0.1	0.3	0.8
Static friction (in-lb)	0.35	.89	2.7	7
Static friction (kgf-cm)	0.4	1.0	3	8
Maximum allowable current (A [peak])	19	18	30	46
Maximum theoretical torque (Nm) **	3.4	11	32	66
Maximum theoretical torque (in-lb) **	30	97	283	584
Maximum theoretical torque (kgf-cm) **	35	112	321	670
Maximum winding temperature rise (°C)	125	125	125	125
Weight (kg)	1.0	3.5	8.5	18
Weight (lb)	2.2	7.2	18.7	39.6
AMPLIFIER				
Model	β SVU-12	β SVU-12	β SVU-20	β SVU-20
Rated output current (rms amps)	3.2	3.2	5.9	5.9
Current limit (Peak amps)	12	12	20	20
AC Power	200–240 VAC (3-phase), 220–240 VAC (1-phase) 50/60 Hz ± 2 Hz			
DC Power	24 VDC ± 10% @ 0.4 Amp per amplifier			
Heat loss (watts)	17.5	17.5	33.3	33.3

* These values are standard values at 20°C with a tolerance of ±10%. The speed-torque characteristics vary, depending on the type of software, parameter setting, and input voltage of the digital servo amplifiers. (The above figures show average values.) These values may be changed without prior notice.

** Theoretical values. The actual maximum torque is restricted by the current limit values of the drive amplifier.

Section 12: β Servo System Options

Designing a servo control system requires that you understand how the electrical and mechanical aspects of your system interact. GE Fanuc application engineers are available to help you determine your servo control system requirements.

Table 30 will help you select which servo options your system requires:

Table 30. β Servo Package Options

Servo Option	Consider Selecting When	Catalog #	Section #
Motor Holding Brake	the system design includes an axis that must hold its position when power is removed	Refer to Table 25	10.3
Absolute Encoder Battery Backup Kit	you would like to avoid having to re-reference the position when power is restored to the control	IC800BBK021	12.1
AC Line Filters	200—240 VAC is already available to the control cabinet and no transformer is used	5.4 kW, 3-phase: A81L-0001-0083#3C 10.5 kW, 3-phase: A81L-0001-0101#C	14.2
Prefinished Cables	the cable lengths available from GE Fanuc are appropriate for your application	Refer to the “Cable Connection” Table 44	15.1
Discharge Resistor	see “Discharging Regenerative Power” section; The 100 Watt discharge resistor is included in all β Series Amplifier Packages	20 Watt Resistor: A06B-6093-H401 100 Watt Resistor: A06B-6093-H402	14.7

12.1 ABSOLUTE ENCODER BATTERY PACKS

All β Series servo motors feature a built-in encoder that can be used in either incremental or absolute mode. In order to utilize the absolute capability, an optional encoder battery pack (IC800BBK021) for the β Series amplifier must be installed. This pack allows the encoder's position information to be backed up so that the machine does not need to be re-referenced to a home position every time power is restored to the servo system.

For optimal panel space utilization, a small lithium battery pack is available that snaps onto the underside of the β amplifier. An integral pigtail cable plugs directly into the CX5 connector. One battery is required for each amplifier.

Absolute Encoder Battery Kit (IC800BBK021) contains the following:

- Battery (A06B-6093-K001)
- Battery Holder (A06B-6093-K002)

Connection Method

(for use with a single amplifier)

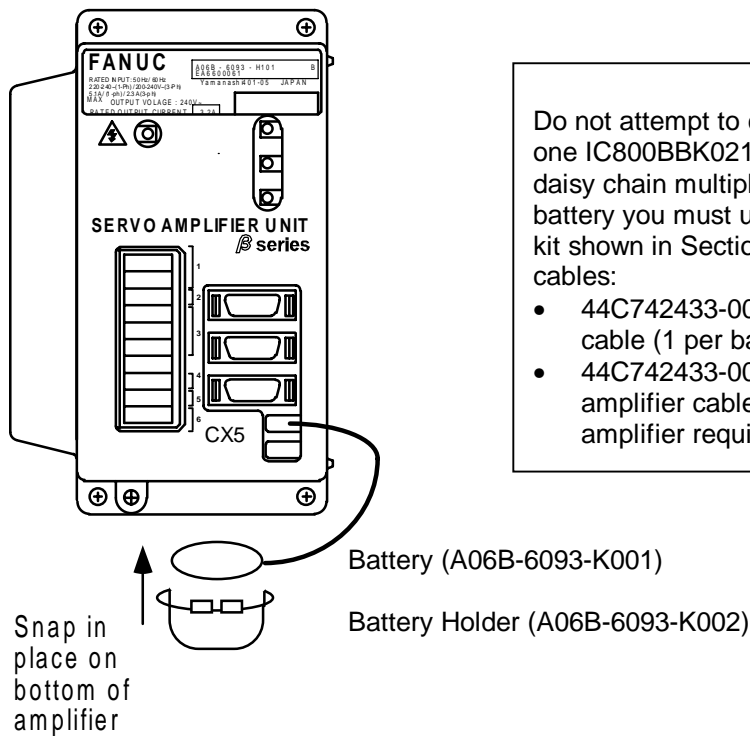

NOTE

Do not attempt to connect multiple amplifiers to one IC800BBK021 battery kit. If you wish to daisy chain multiple β Series amplifiers to one battery you must use the IC800ABK001 battery kit shown in Section 4.2 and the following cables:

- 44C742433-001 2m, battery to amplifier cable (1 per battery required)
- 44C742433-002 250mm, amplifier to amplifier cable (1 for each daisy chained amplifier required)

Figure 29. Connecting a single β Series amplifier to an absolute encoder battery pack

Section 13: Installation Guidelines

This section includes environmental requirements, motor and amplifier dimension drawings and information on ensuring noise protection and selecting a ground fault interrupter.

13.1 MOTOR ENVIRONMENTAL REQUIREMENTS

The servo motor must be installed in a location that satisfies the following environmental conditions:

Table 31. Servo amplifier environmental conditions

Condition	Description
Ambient temperature	The ambient temperature should be -10°C to 40°C. When operating the machine at a temperature higher than 40°C, it is necessary to derate the output power so that the motor's temperature rating is not exceeded.
Vibration	When installed in a machine, the vibration applied to the motor must not exceed 5G.
Altitude	No more than 1,000 m (3,300 ft) above sea level.
Drip-Proof Environment	The motors have a drip-proof structure that complies with IP65 of the IEC standard. Nevertheless, to ensure long-term performance, the motor surface should be protected from solvents, lubricants, and fluid spray. A cover should be used when there is a possibility of wetting the motor surface. Also, to prevent fluid from being led to the motor through the cable, put a drip loop in the cable when the motor is mounted. Finally, turn the motor connector sideways or downward as far as possible. If the cable connector will be subjected to moisture, it is recommended that an R class or waterproof plug be used.

For additional information, see GE Fanuc publication *Servo and Spindle Motors Exposed to Liquids*, GFK-1046.

13.2 SERVO AMPLIFIER ENVIRONMENTAL REQUIREMENTS

The servo amplifier must be installed in a location that satisfies the environmental conditions identified in Table 32 below.

Table 32. Servo Amplifier Environmental Conditions

Condition	Description
Ambient temperature	0°C to 55°C (operating). -20°C to 60°C (storage and transportation).
Temperature fluctuation	Within 1.1°C/min.
Humidity	30% to 95% RH (no condensation).
Altitude	No more than 1000 m (3,300 ft) above sea level.
Vibration	No more than 0.5 G during operation.
Atmosphere	The circuitry and cooling fins must not be exposed to any corrosive and conductive vapor or liquid.

The amplifier must be installed in a cabinet that protects it from contaminants such as dust, coolant, organic solvents, acid, corrosive gas, and salt. Adequate protection must also be provided for applications where the amplifier could be exposed to radiation, such as microwave, ultraviolet, laser light, or x-rays.

In order to adequately protect the amplifier, you must ensure that:

- Contaminants such as dust and coolant, cannot enter through the air inlet or outlet.
- The flow of cooling air is not obstructed.
- The amplifier can be accessed for inspection.
- The amplifier can be disassembled for maintenance and later reinstalled.
- There is sufficient separation between the power and signal lines to avoid interference. Noise protection should be provided.

13.3 β SERVO AMPLIFIER HEAT DISSIPATION AND MAINTENANCE

The amplifier contains a cooling fan that forces air through the unit. Allow for adequate clearance for airflow when installing the amplifier using the recommended distances shown in the drawings below. If possible, do not mount amplifiers one above the other unless they are staggered to prevent the heated exhaust of the lower unit from flowing over the upper unit.

βSVU-12 Maintenance Clearances

βSVU-20 Maintenance Clearances

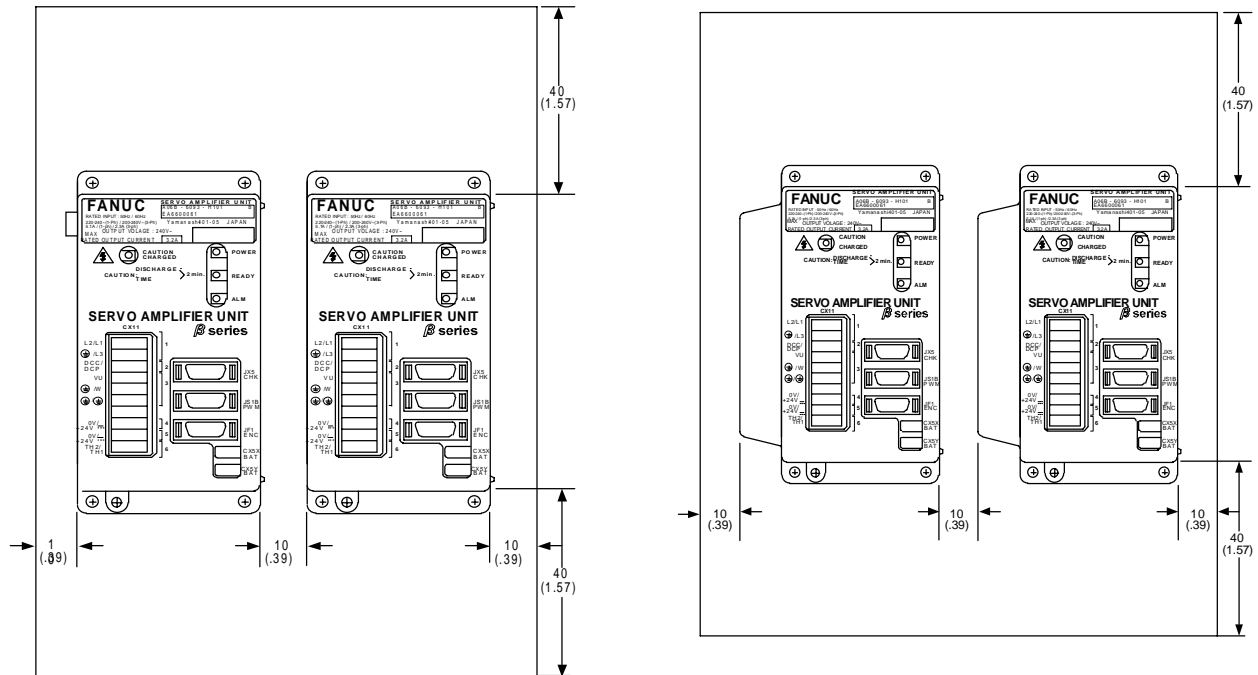

Dimensions shown in mm (in)

Figure 30. β Series amplifier maintenance clearances

Table 33 identifies worst case heat dissipation values for each amplifier. These values may be used to determine heat load for sizing enclosures and cooling equipment. Heat dissipation for external regeneration resistors depends on the application and is calculated in Section 14.7.1, Step 5.

Table 33. Heat Dissipation

Amplifier	Total Heat Dissipation	Catalog #
βSVU-12	17.5 watts	A06B-6093-H101
βSVU-20	33.3 watts	A06B-6093-H102

13.4 β SERIES MOTOR DIMENSIONS

13.4.1 β0.5/3000 Motor, front and side views

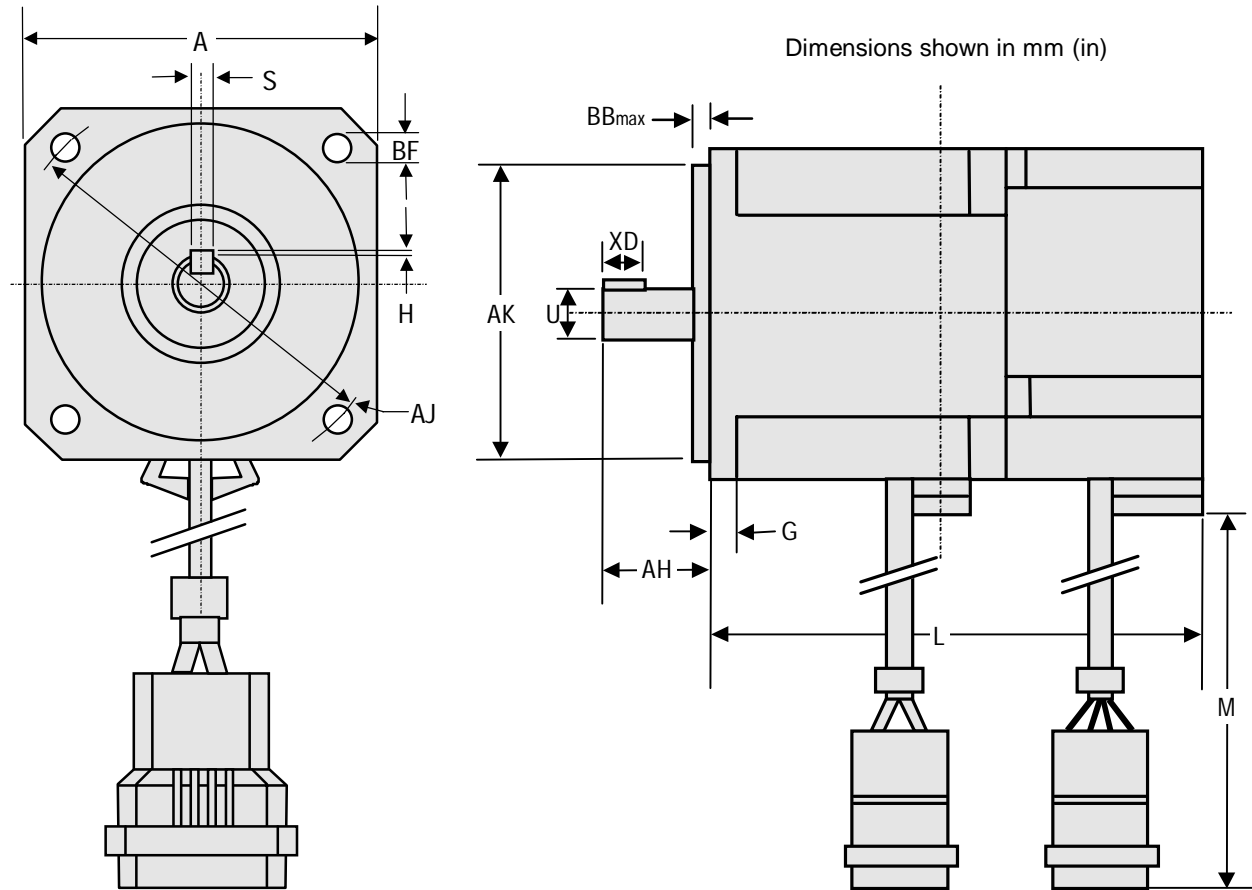

Dim.	MOTOR
	β0.5/3000
A	60 mm (2.36 in)
S	$3^{+0}_{-0.025}$ (0.1181/0.1191)
H	$1.2^{+0}_{-0.125}$ (0.0472/0.0423)
AJ (dia.)	70 (2.76)
BF (dia.)	5.5 (.2165)

NOTES

1. Shaft diameter runout = 0.02 mm max (0.00079 in).
2. Flange surface runout = 0.06 mm max (0.00236 in).
3. Maximum radial load for output shaft is 20 kgf (44 lb).

Dim.	MOTOR	
	β0.5/3000	β0.5/3000 with brake
BB	3 mm (.118 in)	3 mm (.118 in)
XD	20 (.787)	20 (.787)
AK	$50^{+0}_{-0.025}$ (1.9685/1.9675)	$50^{+0}_{-0.025}$ (1.9685/1.9675)
U	$9^{+0}_{-0.009}$ (0.3543/0.3539)	$9^{+0}_{-0.009}$ (0.3543/0.3539)
G	6 (.236)	6 (.236)
AH	25 (.984)	25 (.984)
L	100 (3.94)	128 (5.04)
M	~ 300 (11.81)	~ 300 (11.81)

Figure 31. β0.5/3000 motor, front and side views

13.4.2 β 2/3000, β 6/2000, and α C12/2000 motors, front view

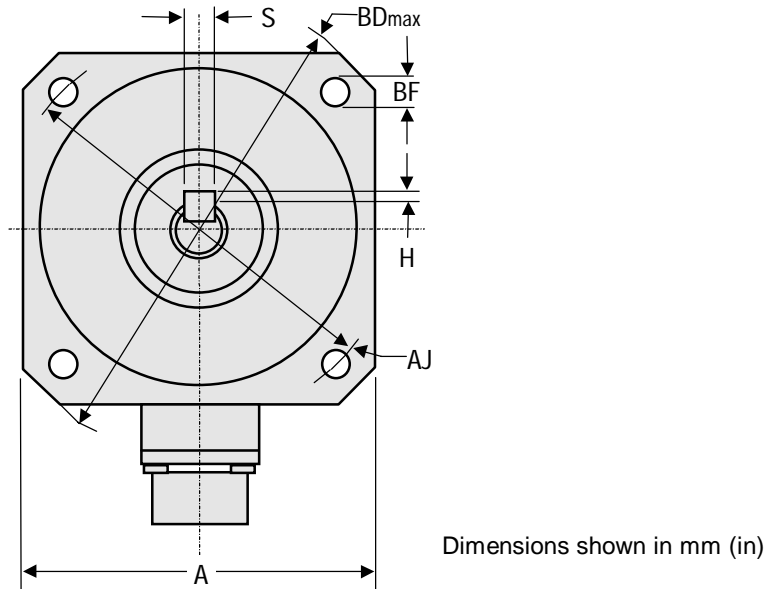

Dimension	MOTOR		
	β 2/3000	β 6/2000	α C12/2000
A	105 mm(4.13 in)	142 mm(5.59 in)	174 mm (6.85 in)
S	$5^{+0}_{-0.03}$ (.1969/.1957)	$6^{+0}_{-0.03}$ (.236/.235)	$10^{+0}_{-0.036}$ (.394/.392)
H	$2^{+0}_{-0.13}$ (.0787/.0736)	$2.5^{+0}_{-0.13}$ (.0984/.0933)	$3^{+0}_{-0.29}$ (.118/.107)
AJ (dia.)	115 (4.53)	165 (6.50)	200 (7.87)
BF (dia.)	9 (.354)	11 (.433)	13.5 (.532)
BD	134 (5.38)	190 (7.48)	240 (9.45)

NOTES FOR ALL VIEWS (see Section 13.4.3 for side view)

1. See the β Connection section (p. 88) for more information about motor cables.
2. Shaft diameter runout = 0.02 mm max (0.00079 in) for β 2/3000 and β 6/2000; 0.05 mm (0.00197 in) for α C12/2000.
3. Flange surface runout = 0.06 mm max (0.00236 in) for β 2/3000 and β 6/2000; 0.10 mm (0.00394 in) for α C12/2000.
4. Maximum radial load for output shaft is 25 kgf (55 lb) for β 2/3000; 70 kgf (154 lb) for β 6/2000; 450 kgf (990 lb) for α C12/2000.

Figure 32. β 2/3000, β 6/2000, and α C12/2000 motors, front view

13.4.3 β2/3000, β6/2000, and αC12/2000 motors, side view

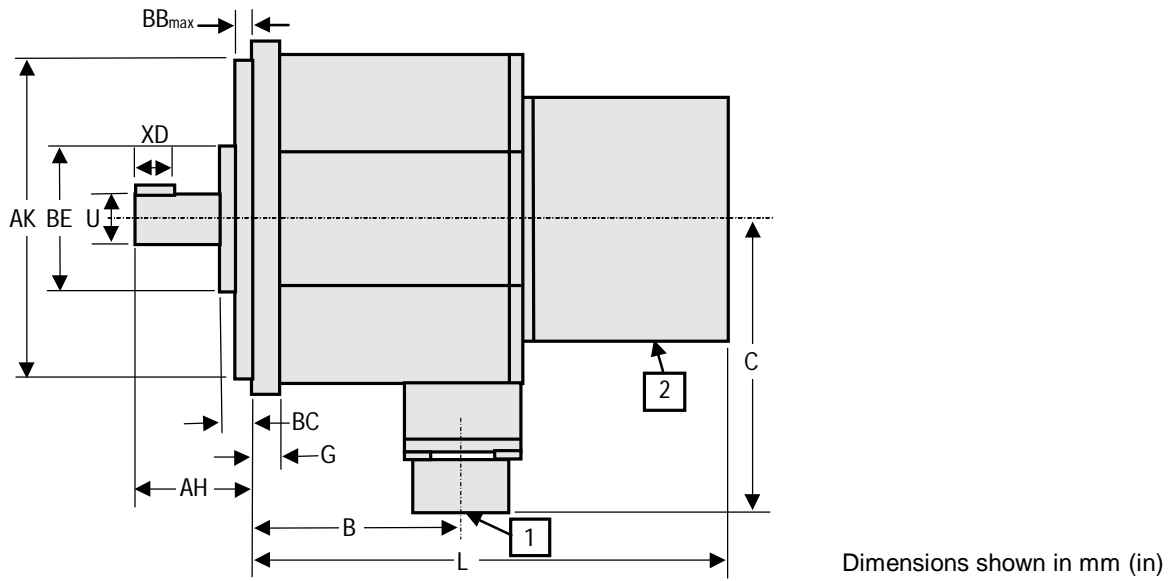

Dimension	MOTOR		
	β2/3000	β6/2000	αC12/2000
BB	5 mm (.196 in)	5 mm (.196 in)	3.2 mm (.126 in)
XD	20 (0.787)	28 (1.10)	70 (2.76)
AK	95 ⁺⁰ _{-0.035} (3.740/3.739)	130 ⁺⁰ _{-0.035} (5.118/5.117)	114.3 ⁺⁰ _{-0.025} (4.50/4.499)
U	14 ⁺⁰ _{-0.011} (0.5512/0.5507)	19 ⁺⁰ _{-0.013} (0.7480/0.7475)	35 ^{+0.01} ₋₀ (1.3783/1.3780)
BC	10 (0.394)	12 (0.472)	N/A
C	88 (3.46)	110 (4.33)	122 (4.80)
G	8 (0.315)	10 (0.394)	18 (0.709)
AH	36 (1.42)	46 (1.81)	79 (3.11)
B	93 (3.66)	117 (4.61)	166 (6.54)
L	174 (6.85)	203 (7.99)	240 (9.45)
BE	43 (1.69)	90 (3.54)	N/A

Connector	Description
1	Motor AC Power
2	Motor Encoder Feedback

Figure 33. β2/3000, β6/2000, and αC12/2000 motors, side view

13.4.4 β2/3000, β6/2000, and αC12/2000 Motors with Brake

(Front view same as β2/3000, β6/2000, and αC12/2000 without brake)

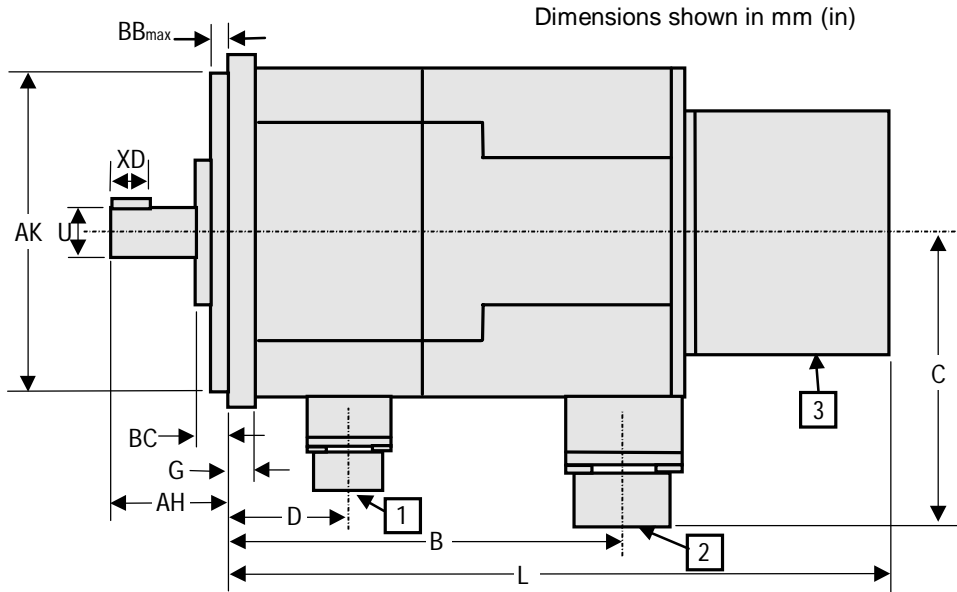

Dimension	MOTOR		
	β2/3000	β6/2000	αC12/2000
BB	5 mm (0.196 in)	5 mm (0.196 in)	3.2 mm (0.126 in)
XD	20 (0.787)	28 (1.10)	70 (2.76)
AK	95 ⁺⁰ _{-0.035} (3.740/3.739)	130 ⁺⁰ _{-0.035} (5.118/5.117)	114.3 ⁺⁰ _{-0.025} (4.50/4.499)
U	14 ⁺⁰ _{-0.011} (0.5512/0.5507)	19 ⁺⁰ _{-0.013} (0.74801/0.74751)	35 ^{+0.01} ₋₀ (1.37831/1.3780)
BC	11 (0.433)	12 (0.472)	N/A
C	88 (3.46)	110 (4.33)	122 (4.80)
G	8 (0.315)	10 (0.394)	18 (0.709)
AH	36 (1.42)	46 (1.81)	79 (3.11)
D	31 (1.22)	28 (1.10)	65 (2.56)
B	149 (5.87)	169 (6.65)	238 (9.37)
L	230 (9.06)	255 (10.04)	312 (12.28)

Tables continued on next page...

Figure 34. β2/3000, β6/2000, and αC12/2000 motors with brake, side view

Connector	Description
1	Brake
2	Motor AC Power
3	Motor Encoder Feedback

NOTES

1. See the Connection section of the manual (p. 88) for more information about motor cables.
2. Shaft diameter runout = 0.02 mm max (0.00079 in) for β 2/3000 and β 6/2000; 0.05 mm (0.00197 in) for α C12/2000.
3. Flange surface runout = 0.06 mm max (0.00236 in) for β 2/3000 and β 6/2000; 0.10 mm (0.00394 in) for α C12/2000.
4. Maximum radial load for output shaft is 25 kgf (55 lb) for β 2/3000; 70 kgf (154 lb) for β 6/2000; 450 kgf (990 lb) for α C12/2000.

13.5 SHAFT LOADING

The allowable load of the motor shaft is as follows:

Table 34. Allowable motor shaft load

Motor Model	Radial Load	Axial Load	Front Bearing (type reference)
β 0.5/3000	20 kg (44 lb)	5 kg (11 lb)	6902
β 2/3000	25 kg (55 lb)	8 kg (17.6 lb)	6003 (without brake)
			6202 (with brake)
β 6/2000	70 kg (154 lb)	20kg (44 lb)	6205
α C12/2000	450 kg (990 lb)	135 kg (297 lb)	6208

NOTES:

- The allowable radial load is the value when a load is applied to the shaft end. It indicates the total continuous force applied to the shaft in some methods of mounting (for example, belt tension) and the force by load torque (for example, moment/pulley radius).
- The belt tension is critical particularly when a timing belt is used. Belts that are too tight may cause breakage of the shaft or premature bearing failure. Belt tension must be controlled so as not to exceed the limits calculated from the permissible radial load indicated above.
- In some operating conditions, the pulley diameter or gear size needs to be checked. For example, when using the model β 6/2000 with a pulley/gear with a radius of 1.5 inches (3.8 cm) or less, the radial load when 230 in-lb of peak torque is provided by the motor will exceed the 154 lb maximum rating. In the case of the timing belt, the belt tension is added to this value, making it necessary to support the shaft end.
- When using a timing belt, shaft failure or bearing overload can be minimized by positioning the pulley as close to the bearing as possible.

- Since a standard single row, deep-groove ball bearing is used for the motor bearing, a very large axial load cannot be used. Particularly when using a worm gear and a helical gear, it is necessary to provide another bearing to isolate the thrust load from the gearing.
- The motor bearing is generally fixed with a C-snap ring, and there is a small play in the axial direction. When this play influences the positioning in the case of using a worm gear and a helical gear, for example, it is necessary to use an additional bearing support.

13.6 β SERIES AMPLIFIERS DIMENSIONS

The β Series amplifiers are panel mounted devices with dimensions as shown in Figure 35. When installing the amplifiers make sure the clearances as shown in Section 13.3.

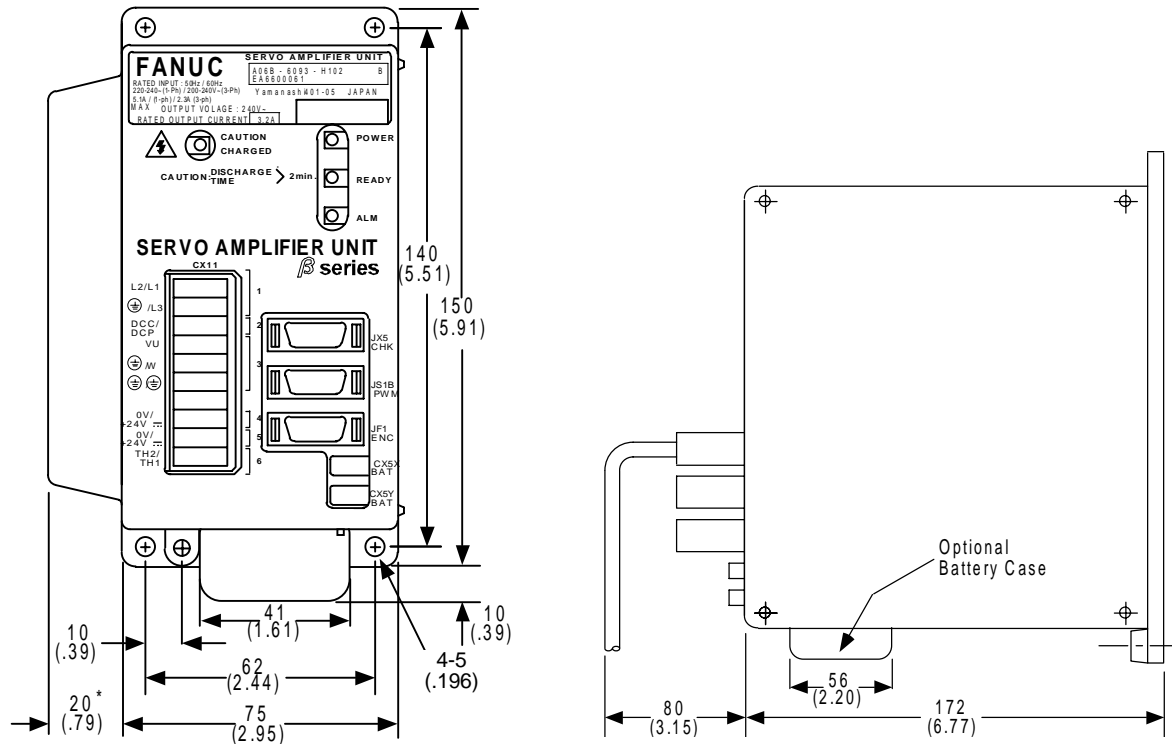

* Measurement applies to the β20 amplifier only. The β12 amplifier does not include the heat sink extension. Dimensions shown in mm (in).

Figure 35. β Series servo amplifier unit, front and side views

13.7 NOISE PROTECTION

13.7.1 Separation of Signal and Power Lines

When routing signal and power lines, the signal lines must be separated from the power lines to ensure best noise immunity. The table below lists the types of cables used:

Table 35. Servo amplifier signal line separation

Group	Signal	Action
A	Amplifier input power line, motor power line, MCC drive coil	Separate these cables from those of group B by bundling them separately* or by means of electromagnetic shielding**. Attach a noise preventer or suppressor, such as a spark arrester, to the MCC drive coil.
B	Cable connecting control unit with servo amplifier and serial encoder feedback cable	Separate these cables from those of group A by bundling them separately or by means of electromagnetic shielding**. In addition, shielding must be provided.

* The bundle of group A cables must be separated from the bundle of group B cables by at least 10 cm.

** Electromagnetic shielding involves shielding groups from each other by means of a grounded metal (steel) plate.

13.7.2 Grounding

A typical machine has three separate grounds:

- **Signal Ground:** Provides the reference potential (0 V) for the electrical signal system.
- **Frame Ground:** Ensures safety and shields external and internal noise.
- **System Ground:** Connects each unit and the inter-unit frame ground system to earth ground.

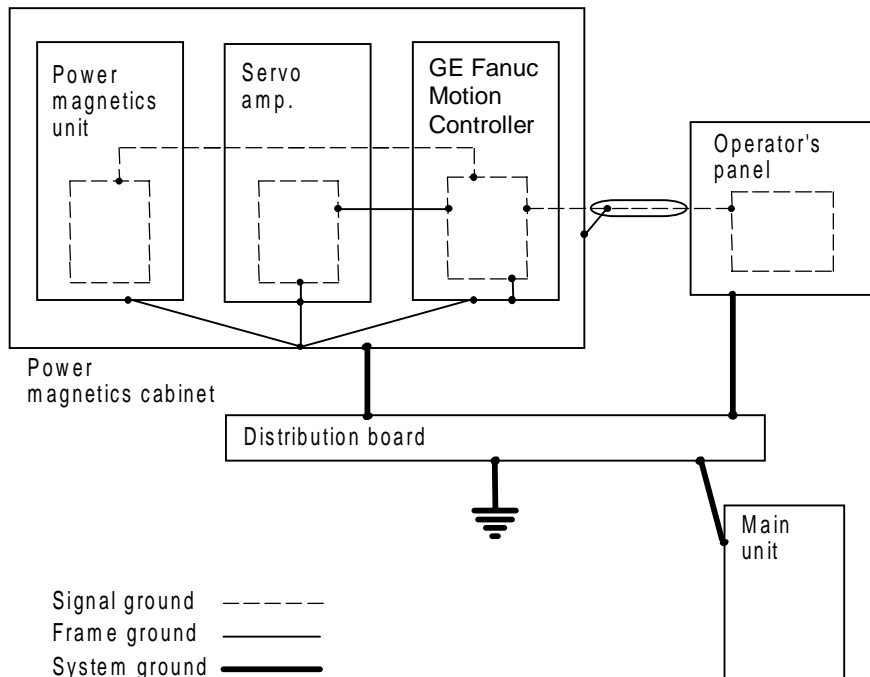

Figure 36. Ground system

Notes on the ground system wiring:

- The ground resistance of the system ground must not exceed 100 ohms (Class-3 ground).
- System ground connection cables must have a sufficiently large cross-sectional area to enable them to safely carry the current that will arise in the event of a problem such as a short-circuit (in general, a cross-sectional area no less than that of the AC power line must be provided).
- The system ground connection cable must be integrated with the AC power line such that power cannot be supplied if the ground wire is disconnected.
- The CX11-3 grounding connector is supplied to provide the servo motor frame ground connection and should always be installed. A separate 1 meter long cable for this connection is included with the optional GE Fanuc prefinished motor power cables.

13.8 COMMAND CABLE GROUNDING

The GE Fanuc controller cables that require shielding should be clamped by the method shown below. This cable clamp treatment provides both cable support (strain relief) and proper grounding of the shield. To ensure table system operation, the cable clamp method is recommended. Partially peel back the cable sheath to expose the shield. Push the clamp (A99L-0035-0001) over the exposed shield and insert the clamp hooks into slots on the grounding bar (44B295864-001). Tighten the clamp to secure cable and complete the ground connection. The grounding bar must be attached to a low impedance earth ground.

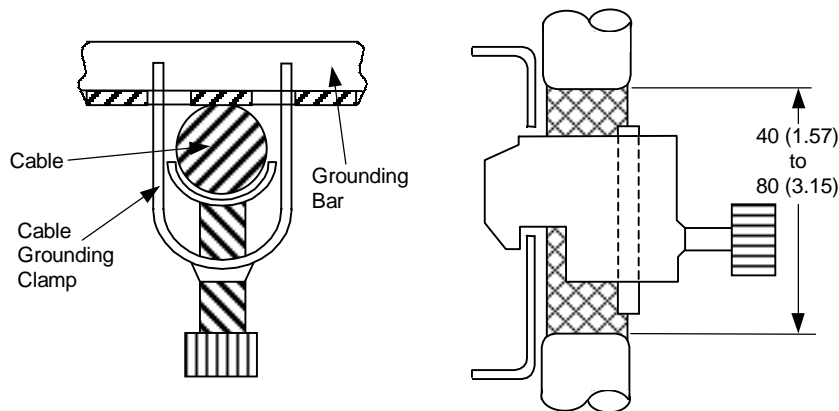

Figure 37. Cable grounding clamp detail

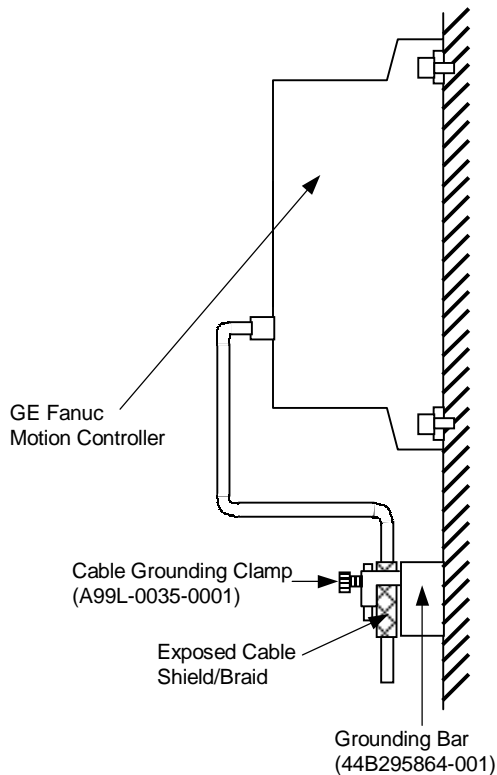

Figure 38. Command cable shield grounding system

13.9 SELECTING A GROUND FAULT INTERRUPTER

The β Series servo amplifier drives a motor by means of the transistor-based PWM inverter method, in which a high-frequency leakage current flows to ground through the stray capacitance of the motor windings, power cable, and amplifier. A ground fault interrupter or leakage-protection relay, which is typically installed on the power supply side, can malfunction if such a leakage current should flow. Therefore, you should select an inverter-compatible ground fault interrupter with the following ratings to protect against the occurrence of this malfunction:

- **β 0.5/3000, β 2/3000, β 6/2000:** choose a 1.8 mA commercial frequency component.
- **α C12/2000:** choose a 2.0 mA commercial frequency component.

Section 14: β Servo System Power Requirements

This section provides information about AC and DC amplifier power as well as the discharge of regenerative power.

14.1 POWER LINE PROTECTION

A circuit breaker, electromagnetic contactor, and AC line filter or transformer should be installed as part of your β Series Servo system. GE Fanuc provides the AC line filter as an option. The transformer, circuit breaker, and electromagnetic contactor, however, are user-supplied components. In European countries where power sources are 380 to 400 VAC and neutral grounded, it is necessary to install a transformer or supply single-phase power.

The same incoming AC control components can be used to provide power to multiple amplifiers, as long as the components are rated for the current and power drawn by the sum of all of the amplifiers.

14.2 AC LINE FILTER

An AC line filter is recommended to suppress the influences of high-frequency input line noise on the drive power supply. When an isolation-type power transformer is used because a power supply voltage within the specified range is not available, an AC line filter is not required.

If two or more servo amplifiers are connected to one AC line filter, the total continuous output rating of all connected servo amplifiers should be kept below the continuous output rating of the AC line filter. The continuous output rating for the various servos are shown below.

Table 36. β Servo Motor Continuous Output Rating

Motor	Cont. Output Rating
β0.5/3000	0.2 kW
β2/3000	0.5 kW
β6/2000	0.9 kW
αC12/2000	1.0 kW

If your installation must be EMC compliant, verify that the use of an AC line filter fully satisfies the EMC requirements. You may need to select and install a user-supplied noise filter in order to meet EMC requirements.

Two AC line filters are available:

- 5.4 kW, 3-phase (A81L-0001-0083#3C)
- 10.5 kW, 3-phase (A81L-0001-0101#C)

For AC line filter specifications and dimension drawings, refer to Section 6.2.

14.3 CIRCUIT BREAKER SELECTION

To provide proper protection for the amplifier, use a circuit breaker rated at no more than 20 Amps (10A for VDE 1601 compliance for CE marking). Table 37 will help you select the appropriate circuit breaker for your motion application.

Table 37. Currents Drawn at Continuous Rated Output

Motor	Input Current 3-phase	Input Current single phase
β0.5/3000	1.9 A (rms)	3.2 A (rms)
β2/3000	3.2 A (rms)	5.1 A (rms)
β6/2000	6.3 A (rms)	10.1 A (rms)
αC12/2000	6.3 A (rms)	10.1 A (rms)

NOTE

When multiple amplifiers are connected to a single circuit breaker, select a breaker by multiplying the sum of the currents listed in Table 37 by 0.6.*

Example: Connecting two β6/2000 motors operating on 3-phase power:

$$(6.3 + 6.3) \times 0.6 = 7.6 \text{ Arms}$$

A standard 10 Amp circuit breaker can be used.

During rapid motor acceleration, a peak current that is three times the continuous rating flows. Select a circuit breaker that does not trip when a current that is three times the continuous rating flows for two seconds.

*This factor attempts to compensate for applications where all axes are not demanding full power at the same time. In applications where all axes are running continuously or with high duty cycles, this factor must be increased by 1.

14.4 ELECTROMAGNETIC CONTACTOR RATING

To prepare for incoming AC power, you must also select and install an appropriate electromagnetic contactor, based on the peak currents for the motors in your system. When multiple amplifiers are connected to a single circuit breaker, select a breaker based on the sum of the currents in Table 37.

14.5 INCOMING AC POWER

Table 38. AC Power

Specification	Description
Voltage: 3-phase 1-phase*	200 VAC to 240 VAC 220 VAC to 240 VAC
Frequency	50 Hz, 60Hz \pm 2 Hz
Voltage fluctuation during acceleration/deceleration	7% or less

* Single-phase operation reduces the lifetime of the servo amplifier. For β 6/2000 and α C12/2000 motors with acceleration/deceleration duty cycles greater than once every 20 seconds, 3-phase power is recommended.

14.5.1 AC Power Ratings

The power supply rating required when using multiple servo motors can be determined by summing the requirements of the individual motors.

The power supply ratings listed in Table 39 are sufficient as continuous ratings. Note, however, that servo motor acceleration causes a current to momentarily flow that is approximately three times the continuous current rating.

When the power is turned on, a surge current of about 37A (when 264VAC is applied) flows for 20 msec.

Table 39. Three-Phase Power Supply Ratings

Motor	Power Supply Rating
β 0.5/3000	0.4kVA
β 2/3000	0.77kVA
β 6/2000	1.4kVA
α C12/2000	1.6kVA

14.6 INCOMING DC POWER

The amplifier requires a 24 VDC power supply for amplifier control power. This DC power supply must be supplied by the user.

The information in Table 40 below will help you select the appropriate DC power supply for your motion application.

The same external DC power supply can be used to provide power to multiple amplifiers as long as the supply is rated for the sum of power drawn by all of the amplifiers. To daisy chain the amplifiers, add connection K13 between amplifiers (see the connection diagram in Section 15.3 for more details).

Table 40. DC Amplifier Control Power Specifications

Specification	Description
Input voltage	24V DC ($\pm 10\%$)
Power supply rating (per amplifier)	0.4 amps

NOTE

The 24 VDC input is fused to protect the amplifier. The fuse labeled F600 is located below the CX11 connector when the amplifier plastic cover is removed. The replacement fuse part number is A06B-6073-K250 (Manufacturer: Daito LM32, DC48V, F3.2A).

A spare fuse is included with each β amplifier package (IC800BPK012 or IC800BPK020)

14.7 DISCHARGING REGENERATIVE ENERGY

Regenerative energy is normally created in applications with a high load inertia or frequent acceleration and deceleration. When decelerating a load, the stored kinetic energy of the load causes generator action in the motor causing energy to be returned to the β Series amplifier. For light loads and low acceleration rates, the amplifier may be able to absorb this energy. Otherwise, an optional external regenerative discharge unit must be installed.

Two separate 30 Ohm regenerative discharge units are available with ratings of 100 W and 20 W. The 100 W unit (A06B-6093-H402) is panel-mounted, whereas the 20 W unit (A06B-6093-H401) mounts to the tapped holes on the side of the amplifier heat sink. Calculations shown later in this section can be used to determine the need for an external unit.

If the regenerative discharge unit overheats, a built-in thermostat is tripped, the external overheat alarm is issued, and the motor is stopped. If an external regenerative discharge unit is required, a separate unit must be installed for each amplifier. This component cannot be daisy-chained. The dimensions for these units are shown in the following drawings. Connections are shown for cables K7 and K8 in Section 15.3 of this document.

14.7.1 Calculating the Average Regenerative Energy

Use the following calculation to determine the average regenerative energy that will be released in your application (ambient temperature is assumed not to exceed 55°C). Based on the calculations select either the 20 W or 100 W regeneration resistor. The wattage rating of the selected resistor must exceed the average calculated regenerative energy from the equation below:

$$\begin{array}{l} \text{Average} \\ \text{Regenerative} \\ \text{Energy (Joules)} \end{array} = \begin{array}{l} \text{Rotational Energy to} \\ \text{be Released during} \\ \text{Deceleration} \\ \text{(STEP 1)} \end{array} - \begin{array}{l} \text{Energy to be} \\ \text{Consumed Through} \\ \text{Axis Friction} \\ \text{(STEP 2)} \end{array} + \begin{array}{l} \text{(only in vertical axis operation)} \\ \text{Vertical Energy to be Released} \\ \text{During Downward Motion} \\ \text{(STEP 3)} \end{array}$$

STEP 1: Rotational Energy to be Released during Deceleration

$$= (6.19 \times 10^{-4}) \times (J_m + J_L) \times \omega_m^2 \text{ Joules}$$

where:

J_m	Motor rotor inertia	(lb-in-s ²)
	$\beta 0.5 = 0.00016$	
	$\beta 2 = 0.00581$	
	$\beta 6 = 0.0347$	
	$\alpha C12 = 0.0555$	
J_L	Load inertia converted to motor shaft inertia	(lb-in-s ²)
ω_m	Maximum motor speed at time of deceleration	(rpm)

STEP 2: Energy to be Consumed through Axis Friction

$$= (5.91 \times 10^{-3}) \times t_a \times \omega_m \times T_L \text{ where:}$$

ω_m	Motor speed during rapid traverse	(rpm)
t_a	Acceleration/deceleration duration during rapid traverse	(sec)
T_L	Axis friction torque (converted to motor shaft torque)	(lb-in)

STEP 3: Vertical Energy to be Released During Downward Motion

(This term applies only in vertical axis operation)

$$= (1.182 \times 10^{-2}) \times T_h \times \omega_m \times \frac{D}{100} \text{ where:}$$

T_h	Upward supporting torque applied by the motor during downward rapid traverse	(lb-in)
ω_m	Motor speed during rapid traverse	(rpm)
D	Duty cycle of downward vertical operation during rapid traverse	(%)

(Note: the maximum value of D is 50%. D assumes a smaller value)

STEP 4: Determine if a Regenerative Discharge Unit Is Required

Determine the Average Regenerative Energy using the equation in the beginning of this section.

When the average regenerative energy produced never exceeds the amounts that is indicated in Table 41 below, a separate regenerative discharge unit is **not** required:

Table 41. Maximum Allowable Regenerative Energy for Amplifiers

Amplifier	Max. Allowable Regen. Energy	Used with Motors
βSVU-12	13 Joules	β0.5, β2
βSVU-20	16 Joules	β6, αC12

If the calculated value exceeds the storage capability of the amplifier, then an external regenerative discharge unit is required (see Step 5).

STEP 5: Selecting a Regenerative Discharge Unit

If a separate regenerative discharge unit is required, the following calculation will determine whether the 20 W or 100 W unit is required:

Average Regenerative Power (W) = Average Regenerative Energy (Joules) x $\frac{1}{F}$ where:

F = Deceleration duty (seconds) Example: deceleration once per 5 second cycle, F=5

Select a regenerative resistor with a rating that exceeds the average regenerative power. If this value is greater than 100 W, contact GE Fanuc for assistance.

Example:

Assume a horizontal axis using a β2 motor ($J_m = 0.00581 \text{ lb-in-s}^2$) that decelerates once every 6 seconds (F) for 0.2 seconds (t_a) with a maximum speed of 2000 RPM (ω_m). The machine inertia (J_L) is 0.0139 lb-in-s².

STEP 1: Rotational Energy = $(6.19 \times 10^{-4}) \times (0.00581 + 0.0139) \times 2000^2 = 54.4 \text{ Joules}$

STEP 2: Assuming $T_L = 10 \text{ in-lb}$:
Friction Energy = $(5.91 \times 10^{-3}) \times 0.2 \times 2000 \times 10 = 23.64 \text{ Joules}$

Therefore:

STEP 4: Average Regenerative Energy = $54.4 - 23.64 = 30.76 \text{ Joules}$
Because the 30.76 Joules required is more than the 13 Joules allowed by the βSVU-12 amplifier used with the β2 motor, a regenerative resistor is required.

STEP 5: Since the application requires decelerations every 6 seconds, $\frac{1}{F} = \frac{1}{6}$

Average Regenerative Power = $30.76 \text{ Joules} / 6 \text{ seconds} = 5.13 \text{ W}$
Therefore, the 20 W resistor (A06B-6093-H401) is adequate for this application.

Section 15: β Servo System Connection

When planning your system, it is important to determine how the different parts of the system connect together. Cable reference numbers K1 through K15 on the Beta Servo Connection Diagram on p. 90. Details for each connection are shown in Section 15.3.

15.1 SYSTEM CONNECTIONS

β Series motor and amplifier connectors required for the system are available from GE Fanuc.

GE Fanuc supplies connectors in order to allow you to manufacture cables to the specific length required by your system design. GE Fanuc does offer finished cables as options for many connections. See the Cable Connections chart on p. 88 for more information.

A (Part number A06B-6093-K301) and E-Stop connector (A02B-0120-K321) are shipped with each β Series servo amplifier package. Kit components are not sold separately. The contents of the connector kit are described below: .

Table 42. β Connector Kit Contents (A06B-6093-K301)

Qty.	Part Number	Description
3	A63L-0001-0460/025KD	CX11-3 (Ground), CX11-4, -5 (24 VDC) single wide connectors
2	A63L-0001-0460/045KD	CX11-1 (Power), CX11-3 (Motor Power) double wide connectors
10	A63L-0001-0456/ASL	CX11 contacts
4	A63L-0001-0456/ASM	CX11 contacts
1	A660-8011-T604	CX11-6 prewired jumper for discharge resistor thermal switch (must be used when external discharge resistor is not installed)

Optional connectors are also available for the various motor power and feedback cables.

Table 43. Available Motor Power and Feedback Cable Connectors for β Servo Systems

Part Number	Description
A06B-6050-K119	Motor Power Connector Kit, β0.5/3000
44A730464-G18	Motor Power Connector Kit, β2/3000 and β6/2000
A06B-6050-K120	Motor Encoder Connector Kit, β0.5/3000
A06B-6050-K115	Motor Encoder Connector Kit, β2/3000 and β6/2000
A06B-6050-K214	β Series Amplifier Encoder Feedback Connector Kit (JF1)
44A730464-G26	Motor Brake Connector Kit (not required for β0.5 motor with brake)

β and α Series Servo Product Specifications Guide

Table 44. Cable Connections.

Ref.	Connects	Prefinished Cable Part Number	Connection Type	When Required
K1	DSM302 to Amplifier (JS1B)	IC800CBL001 (1m) IC800CBL002 (3m)	Servo Command Signal	always
K1	All Other GE Fanuc Controllers to Amplifier (JS1B)	IC800CBL003 (2m)	Servo Command Signal	
K2	Built in Serial Motor Encoder to Amplifier (JF1)	IC800CBL022 severe duty, 14 m (β0.5/3000) IC800CBL023 severe duty, 14 m (β2/3000, β6/2000) IC800CBL021 severe duty, 14 m (αC12/2000)	Motor Encoder Feedback	always
K3	AC Power Components to Amplifier	N/A	3 Phase Servo Power	always
K4	Amplifier to Motor (Prefinished cable includes separate cable to connect motor frame ground to customer's earth ground.)	IC800CBL064, 14 m (β0.5/3000) IC800CBL065, 14 m (β2/3000, β6/2000) IC800CBL066, 14 m (αC12/2000)	Motor Power	always
K5	Servo Amplifier Emergency Stop Input (JX5) to Machine E-Stop Contact	N/A	Emergency Stop	always
K7	Amplifier to Regenerative Discharge Unit	N/A (included with regenerative discharge unit)	Regenerative Power Discharge	in most cases ¹
K8	Regenerative Discharge Unit Over Temperature Switch to Amplifier	N/A (included with regenerative discharge unit)	Regenerative Power Discharge	in most cases ¹
K9	Amplifier (CX5) to Backup Battery Holder	N/A	Absolute Encoder Battery	with battery option ²
K10	Control to MCC Coil	N/A	Emergency Stop/Power Enable	control-dependent; consult your control documentation
K12	External 24 VDC Power Supply to Amplifier	N/A	24 VDC Amplifier Power	always
K13	Amplifier to Second Amplifier	N/A	24 VDC Amplifier Power	when daisy chaining amplifiers
K14	90 VDC Brake Power Supply to Motor Brake	44C742238-004. 14m (β2/3000, β6/2000, αC12/2000)	Motor Brake Power	with brake option ³
K15	MCC Contact to Control	N/A	Control Enable	always

¹ See Discharging Regenerative Energy in Section 14.7

² Prefinished cable is provided as a part of a battery pack option

³ Prefinished motor power cables supplied by GE Fanuc for β 0.5/3000 motor includes brake wiring.

15.2 β SERIES CONNECTION DIAGRAM

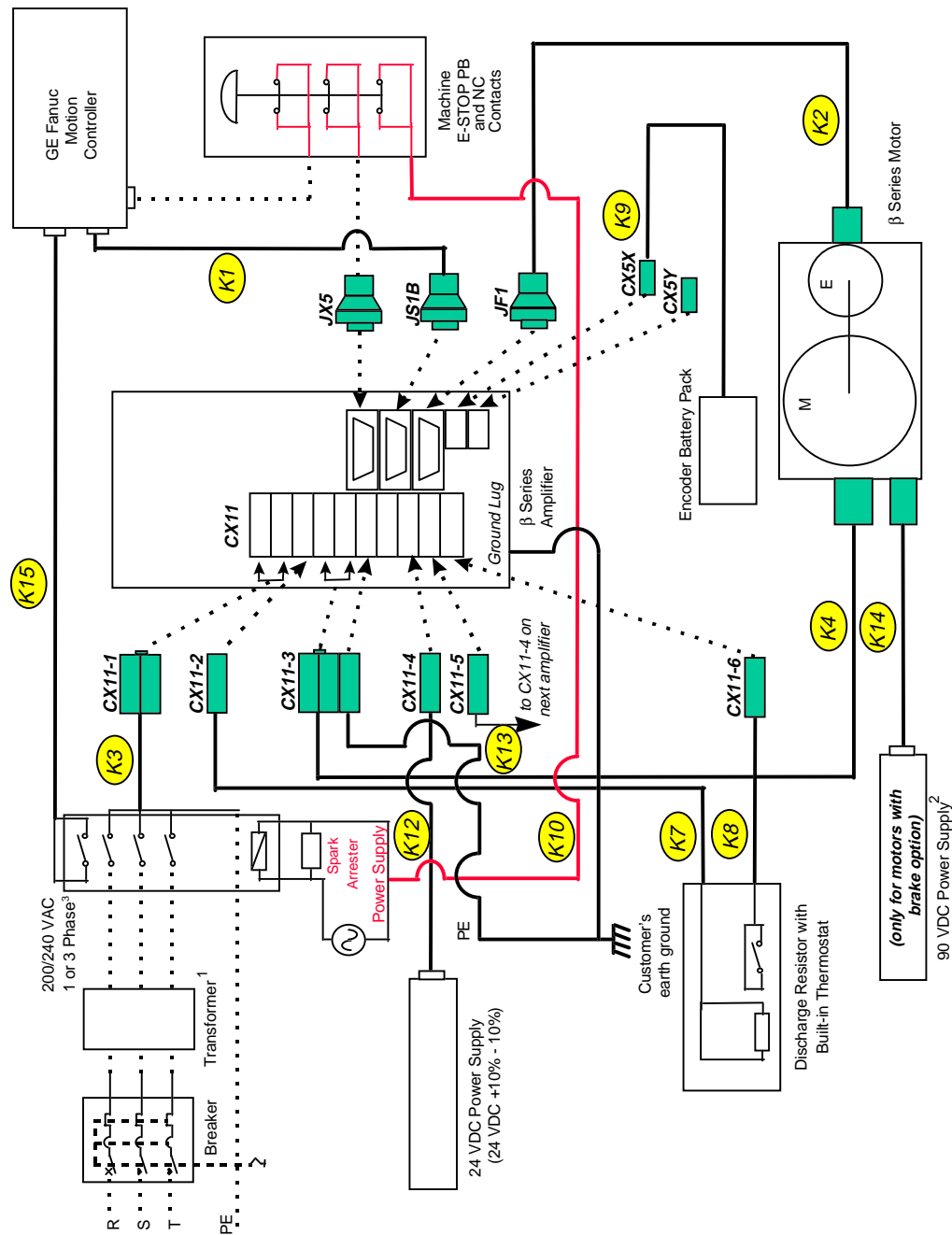

KEY:

- available GE Fanuc cable
- user-supplied cable

Figure 39. Cable connection diagram

¹ Line filter and lightning surge absorber can be used in place of a transformer when 200–240 VAC is available to the cabinet.

² Refer to the note in Section 10.3 regarding the motor holding brake.

³ For single-phase operation, AC line phase T is not connected. Refer to the Servo System Specifications in Section 11: for output current derating.

15.3 CONNECTION DETAILS

K1— Servo Command Signal Cable (β0.5/3000, β2/3000, β6/2000, αC12/2000)

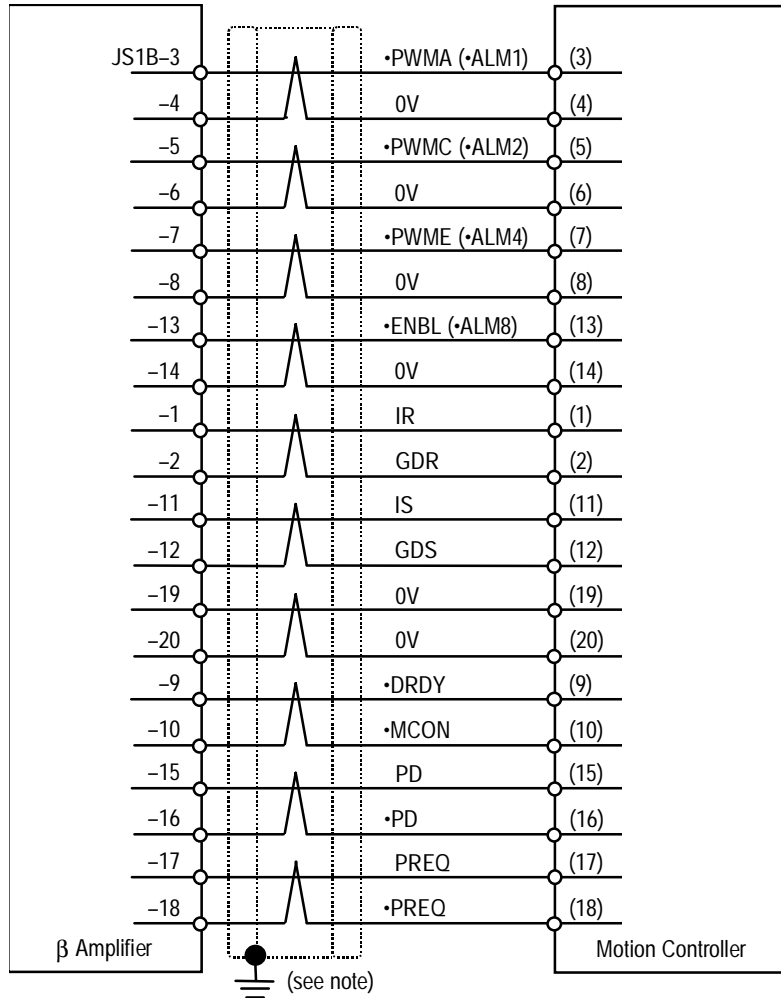

NOTES

The servo command cables for the DSM300 Series controller (IC800CBL001 and IC800CBL002) must be purchased from GE Fanuc. Proper tooling is required to assemble the connectors. For custom length cables, contact your GE Fanuc Distributor or GE Fanuc Sales Engineer.

Grounding the cable shield using the grounding bar (44B295864-001) and cable grounding clamp (A99L-0035-0001) will provide greater noise immunity.

- Wire: 0.08mm² twisted pair group shielded cable (10 pairs). The following wire is recommended for the K1 cable: 28 AWG x 10 pairs (20 conductors).

α and β Series Servo Product Specifications Guide

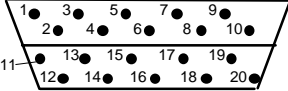
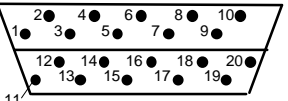
Cable (K1)	GE Fanuc Part No.	Connector Manufacturer
DSM302 to Servo Amplifier (JS1B)	IC800CBL001 (1 meter) IC800CBL002 (3 meter)	Cable must be purchased from GE Fanuc (connectors not sold separately)*
GE Fanuc controller other than DSM302 to Servo Amplifier (JS1B)	IC800CBL003 (2 meter)	<p>Hirose Electric Co., Ltd.</p>  <p>Honda Tsushin Kogyo Co., Ltd. (PCR-E20FA)</p>  <p><i>Connectors viewed from back (solder/crimp side).</i></p>

***NOTE:** DSM302 cables cannot be customer-manufactured and uses a 36-pin connector on its end. The DSM302 module requires IC693ACC355 Axis Terminal Board and either IC693CBL324 (1 meter) or IC693CBL325 (3 meter) Terminal Board Cable to access axis I/O such as Home Switch Input, Over Travel Inputs, or Strobe (registration) Inputs.

K2—Motor Encoder Feedback Cable (β0.5/3000)

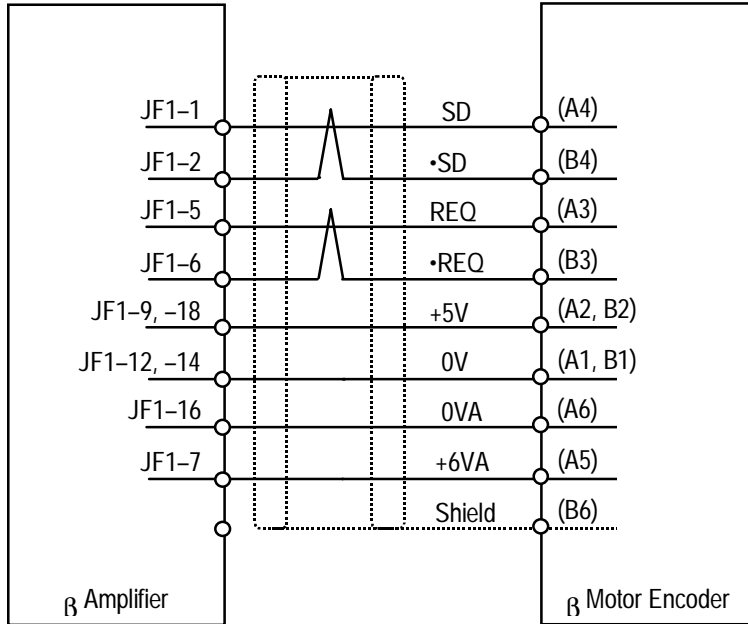

- Prefinished 14m Cable, Part number: IC800CBL022
- Wire: for +5V, 0V use two parallel conductors of 0.5mm² (20 AWG) or larger when the wire length does not exceed 14m. When the wire length exceeds 14m, wire gauge must be increased to ensure that the sum of the electrical resistance of 0V and 5V circuit does not exceed 0.5 ohms. For 6VA, 0VA use 0.5mm² (20 AWG) or larger; for SD, *SD, REQ, *REQ use 0.18mm² (24 AWG) or larger twisted pair with 60% braid shield.

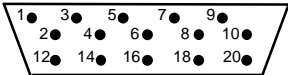
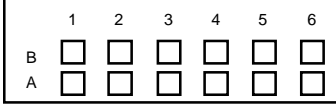
Connector	GE Fanuc Part No.	Manufacturer
Servo Amplifier (JF1)	A06B-0120-K301	Hirose Electric Co., Ltd. (connector:FI40-2015S) (connector cover: F1-20-CV)  <i>Connector viewed from back (solder/crimp) side.</i>
Servo Motor Encoder	A06B-6050-K120	SMP (connector: 178289-6 pin: AMP 1-175217-2) 

K2—Motor Encoder Feedback Cable (β2/3000, β6/2000)

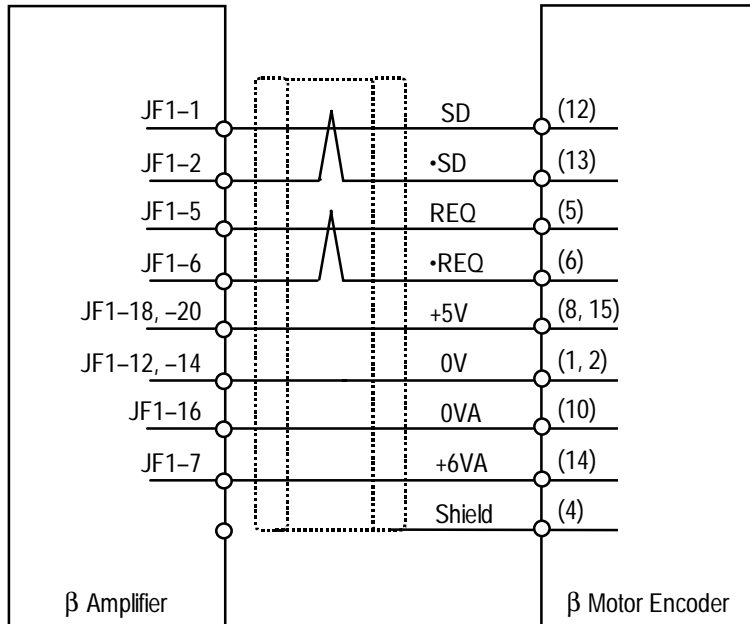

- Prefinished 14m Cable, Part number: IC800CBL023 (severe duty)
- Wire: for +5V, 0V use two parallel conductors of 0.5mm² (20 AWG) or larger when the wire length does not exceed 14m. When the wire length exceeds 14m, wire gauge must be increased to ensure that the sum of the electrical resistance of 0V and 5V circuit does not exceed 0.5 ohms. For 6VA, 0VA use 0.5mm² (20 AWG) or larger; for SD, *SD, REQ, *REQ use 0.18mm² (24 AWG) or larger twisted pair with 60% braid shield.

Connector	GE Fanuc Part No.	Manufacturer
Servo Amplifier (JF1)	A06B-0120-K303	Hirose Electric Co., Ltd. (connector: FI40-2015S) (connector cover: FI-20-CV)
Servo Motor Encoder	A06B-6050-K115	Hirose Electric Co., Ltd. (HDAB-15S) [connector cover: HDAW-15-CV (waterproof), HAD-CTH] <i>Connectors viewed from back (solder/crimp side).</i>

NOTE

Cable includes two M4 x 12mm screws and captive lock washers for securing connector to motor encoder housing.

K2—Motor Encoder Feedback Cable (αC12/2000)

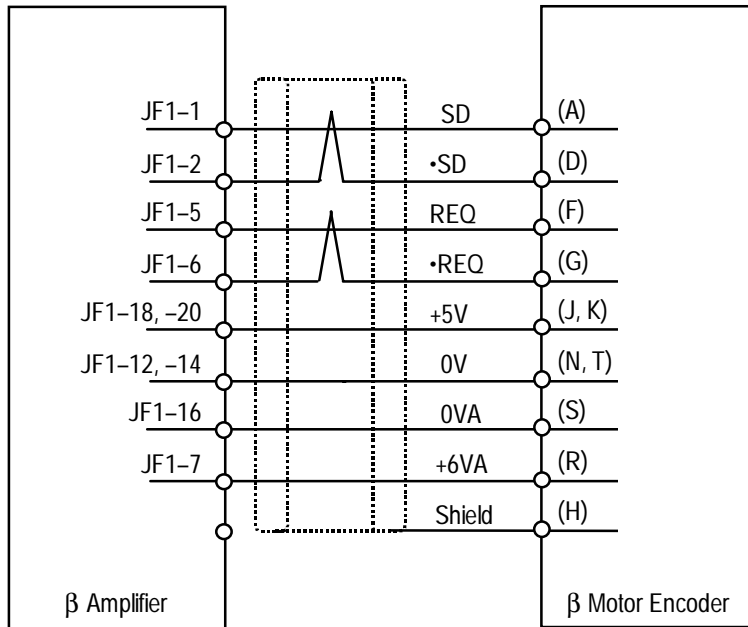

Prefinished 14m Cable, Part number:

IC800CBL021 (severe duty)

- Wire: for +5V, 0V use two parallel conductors of 0.5mm² (20 AWG) or larger when the wire length does not exceed 14m. When the wire length exceeds 14m, wire gauge must be increased to ensure that the sum of the electrical resistance of 0V and 5V circuit does not exceed 0.5 ohms. For 6VA, 0VA use 0.5mm² (20 AWG) or larger; for SD, *SD, REQ, *REQ use 0.18mm² (24 AWG) or larger twisted pair with 60% braid shield.

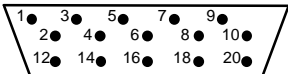
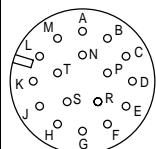
Connector	GE Fanuc Part No.	Manufacturer
Servo Amplifier (JF1)	A02B-0120-K303	Hirose Electric Co., Ltd. (F140-2015S) [connector cover: FI-20-CV]  Connector viewed from back (solder/crimp side).
Servo Motor Encoder	44A730464-G24 (CE EXT GND pin type)	Hirose Electric Co., Ltd. (MS3106A 20-29SW, straight) (MS3108B 20-29SW, elbow) 

K3—Three-Phase Servo Power Cable (user-supplied)

For a power supply voltage of 200/220/230/240 VAC 50/60 Hz (220 VAC minimum for single-phase)

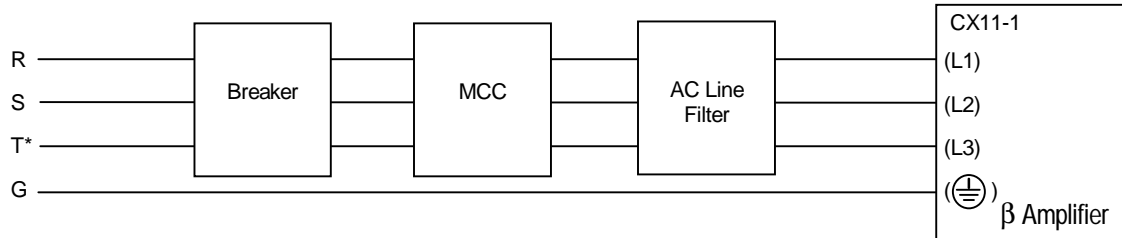

Main Power Supply

* For single-phase operation, phase T is not connected



- Wire: 600V, 4-conductor, 1.0mm² (18 AWG) or larger. For sourcing multiple amplifiers from the same AC supply, size conductors based on the sum of the current for all amplifiers (see specifications in Section 11:

Connector	GE Fanuc Part No.	Manufacturer
Servo Amplifier CX11-1	Part of Kit A06B-6093-K301	Nihon AMP (175363-1, 175363-1 Housing; 1-175218-2 Contact)

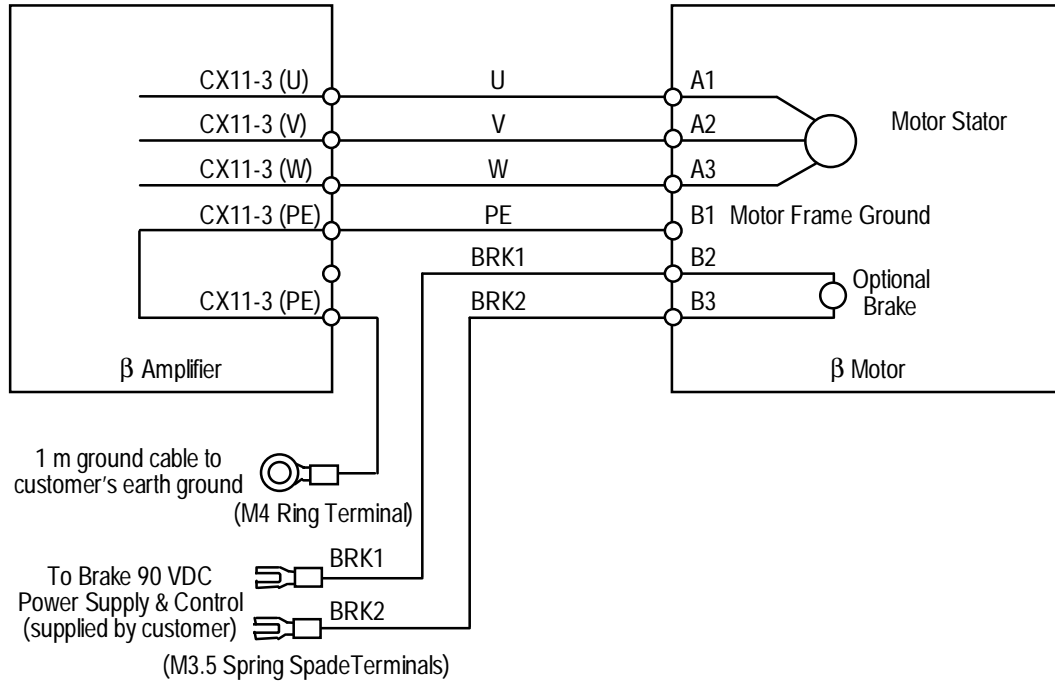
K4—Motor AC Power Cable (β0.5/3000)

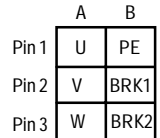

- Prefinished 14m Cable, Part number: IC800CBL064 (severe duty)
- Wire: 300V, 6-conductor, 20 AWG (finestrand) 80°C, polyurethane jacket with PVC conductors (nominal cross-sectional area 0.75mm²). Ground wire is 18 AWG, 300 V, 1-conductor, 80°C, PVC, green with yellow stripe.

Connector	GE Fanuc Part No.	Manufacturer
Servo Amplifier CX11-3 (motor power)	Part of Kit A06B-6093-K301	Nihon AMP (Housing: 175363-1; Contact: 1-175217-2) 
Servo Amplifier CX11-3 (ground)	Part of Kit A06B-6093-K301	Nihon AMP (Housing: 175362-1; Contact: 1-175218-2) 
Servo Motor	A06B-6050-K119	Nihon AMP (Housing: 3-178129-6; Contact: 1-175217-2) 

K4—Motor AC Power Cable (β2/3000, β6/2000)

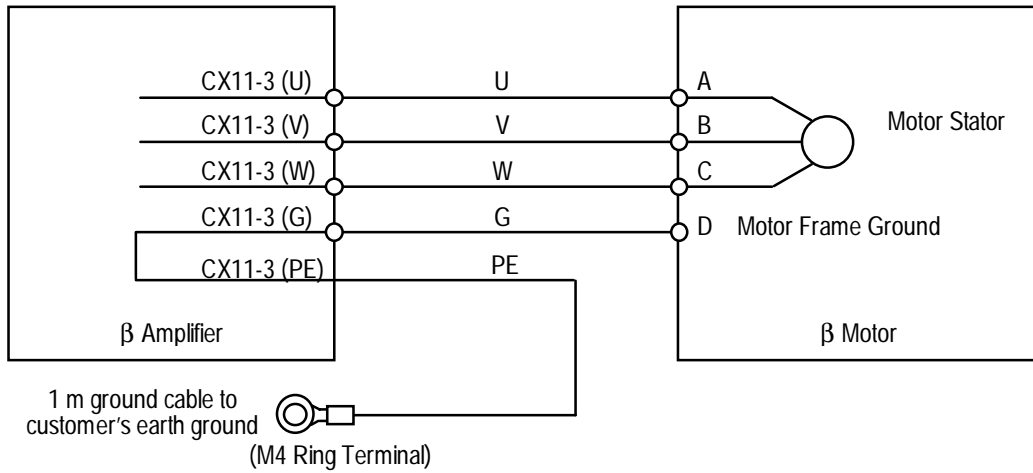

- Prefinished 14m Cable, Part number: IC800CBL065 (severe duty)
- Wire: 300V, 4-conductor, 18 AWG (finestrand) 80°C, polyurethane jacket (PUR) with PVC conductors (nominal cross-sectional area 0.75mm²). Ground wire is 18 AWG, 300 V, 1-conductor, 80°C, PVC, green with yellow stripe.

Connector	GE Fanuc Part No.	Manufacturer
Servo Amplifier CX11-3 (motor power)	Part of Kit A06B-6093-K301	Nihon AMP (Housing: 175363-1; Contact: 1-175218-2)
Servo Amplifier CX11-3 (ground)	Part of Kit A06B-6093-K301	Nihon AMP (Housing: 175362-1; Contact: 1-175218-2)
Servo Motor	Customer-made cable: 44A730464-G18 (CE EXT GND pin)	

K4—Motor AC Power Cable (αC12/2000)

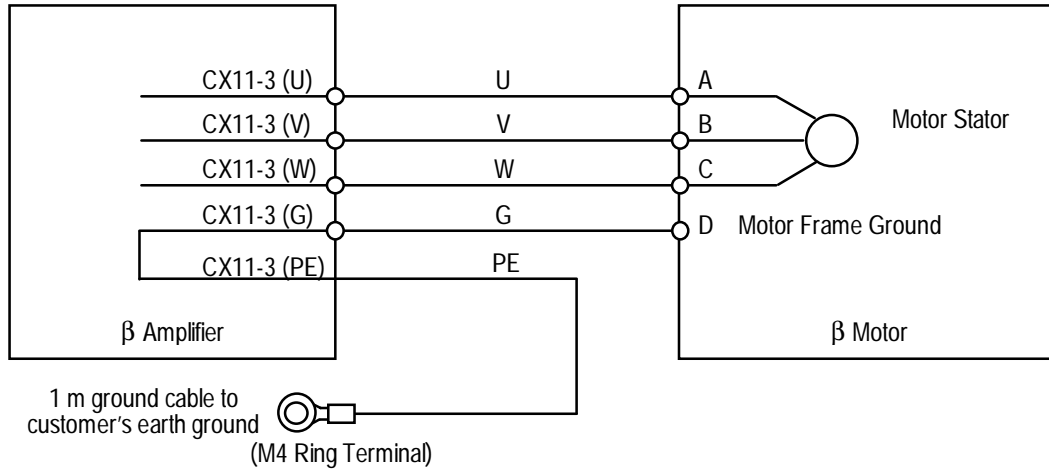

- Prefinished 14m Cable, Part number: IC800CBL066
- Wire: 300V, 4-conductor, 18 AWG (finestrand) 80°C, polyurethane jacket with PVC conductors (nominal sectional area 0.75mm²). Ground wire is 18 AWG, 300 V, 1-conductor, 80°C, PVC, green with yellow stripe.

Connector	Part No.	Maker
Servo Amplifier CX11-3 (motor power)	Part of Kit A06B-6093-K301	Nihon AMP (Housing: 175363-1; Contact: 1-175218-2)
Servo Amplifier CX11-3 (ground)	Part of Kit A06B-6093-K301	Nihon AMP (Housing: 175362-1; Contact: 1-175218-2)
Servo Motor	Customer-made cable: 44A730464-G20 (CE EXT GND pin)	

K5—Servo Amplifier Emergency Stop Connection

If two to six amplifier units are used in the same system, the emergency stop signal must be connected as shown below:

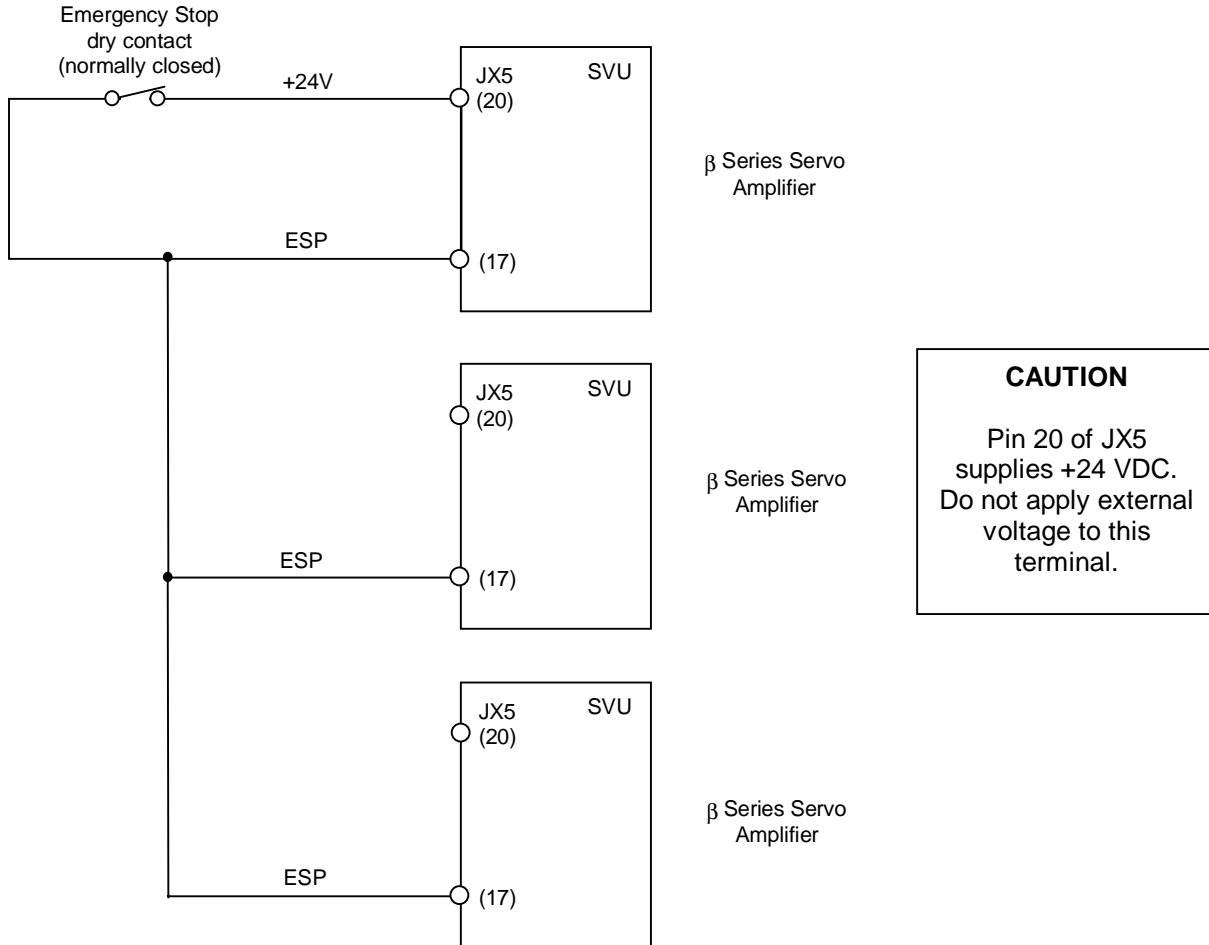

Connector	GE Fanuc Part No.	Manufacturer
JX5	A02B-0120-K301	<p>Hirose Electric Co., Ltd. (F140-2015S; F1-20-CV cover)</p> <p>Honda Tsushin Kogyo Co., Ltd. (PCR-E20FA)</p> <p>Connectors viewed from back (solder/crimp side).</p>

K7—Regenerative Power Discharge Cable (β2/3000, β6/2000, αC12/2000)

K8—Regenerative Power Discharge Thermal Protection Cable

(Resistor includes amplifier connectors and contacts)

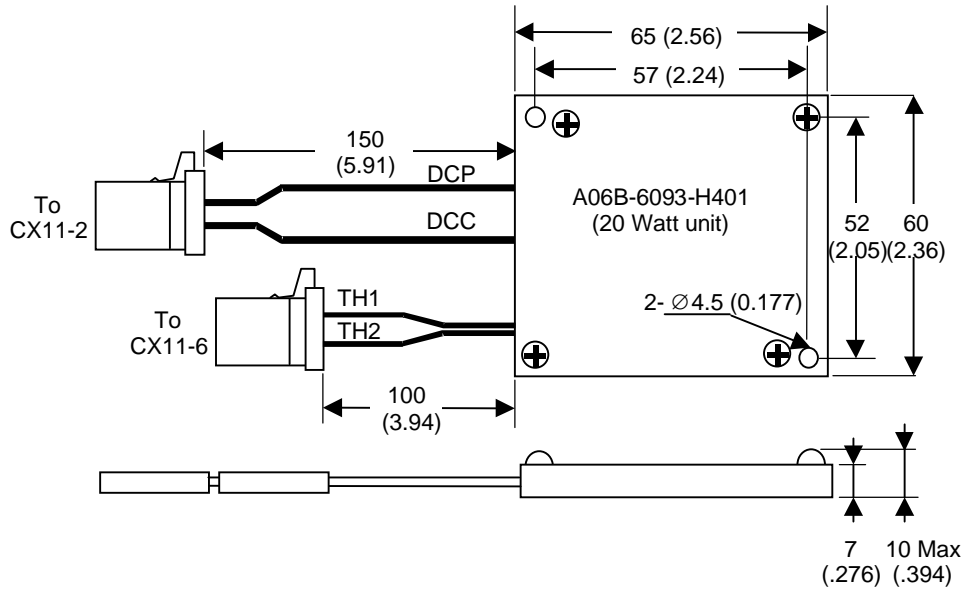
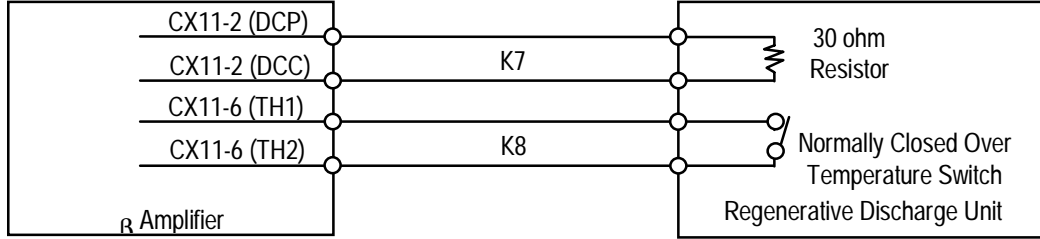

NOTE
Resistor kit contains two standoffs and mounting hardware

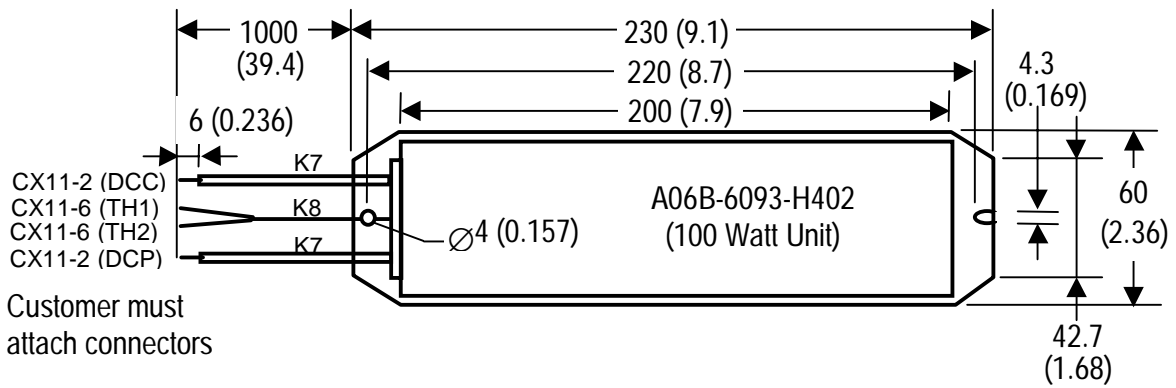

dimensions shown in mm (inches)

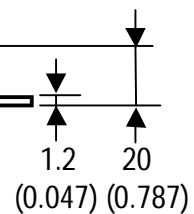

α and β Series Servo Product Specifications Guide

Connector	GE Fanuc Part No.	Manufacturer
Servo Amplifier CX11-2, -6	Part of Kit A06B-6093-K301	Nihon AMP (Housing: 175362-1; Contact: 1-175218-2) <div style="display: flex; justify-content: space-around; align-items: center;"> <div style="border: 1px solid black; padding: 2px; margin: 2px;">□ DCP</div> <div style="border: 1px solid black; padding: 2px; margin: 2px;">□ TH1</div> </div> <div style="display: flex; justify-content: space-around; align-items: center;"> <div style="border: 1px solid black; padding: 2px; margin: 2px;">DCC</div> <div style="border: 1px solid black; padding: 2px; margin: 2px;">TH2</div> </div>

K9—Absolute Encoder Battery Cable (β0.5/3000, β2/3000, β6/2000, αC12/2000)

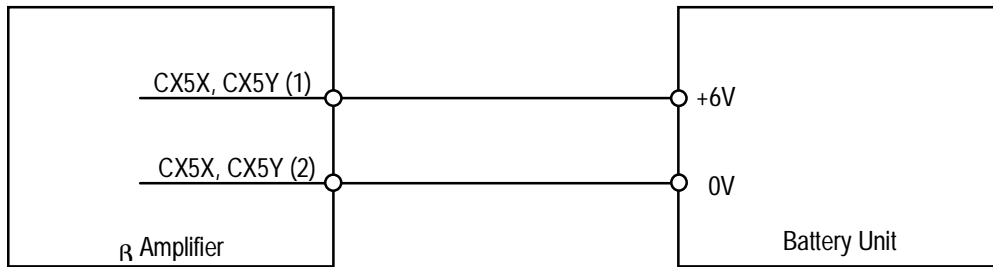

- Wire: Nominal sectional area 0.32mm² (24 AWG) or less

Connector	GE Fanuc Part No.	Manufacturer
Servo Amplifier (CX5X)	A06B-6093-K303	Japan Aviation Electronics Industry (Housing: IL-L2S-S3L-B(N); Contact: IL-C2-1-00001)

K10—Emergency Stop/Power Enable Cable (β0.5/3000, β2/3000, β6/2000, αC12/2000)

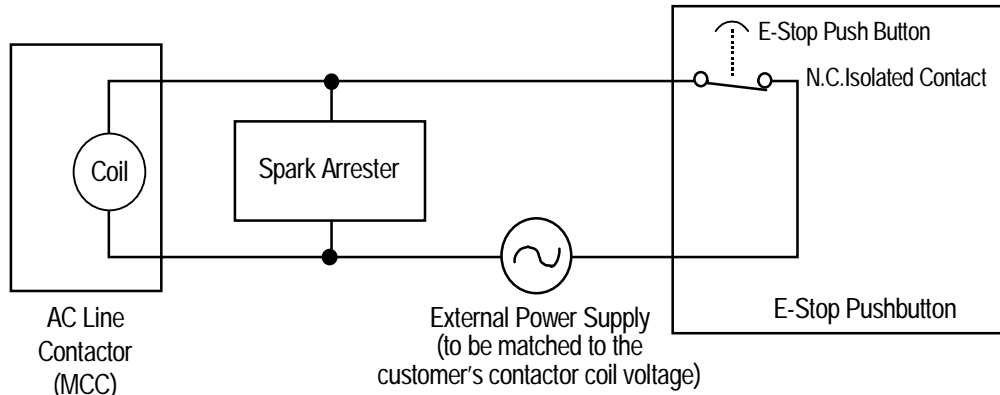

- Cable Specification: Heavy-duty vinyl power cord, 2-conductor 0.5mm² (20 AWG)
- Spark Arrester: To protect internal contacts, always use a spark arrester appropriate for the contactor you select.

K12—24 VDC Amplifier Power Cable (β0.5/3000, β2/3000, β6/2000, αC12/2000)

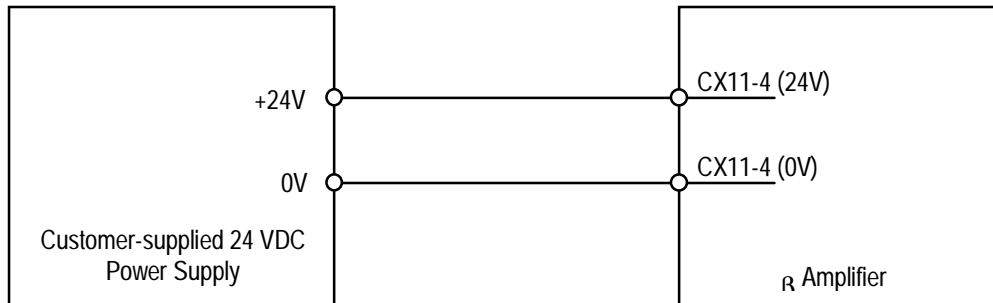

- Wire: Nominal sectional area 1.42mm² (16 AWG)–0.5mm² (20 AWG)

Connector	GE Fanuc Part No.	Manufacturer
DC Power Supply	N/A	N/A
Servo Amplifier CX11-4	Part of Kit A06B-6093-K301	Nihon AMP (Housing: 175362-1; Contact: 1-175218-2)

K13—24 VDC Amplifier Power Daisy Chain Cable (β0.5/3000, β2/3000, β6/2000, αC12/2000)



- Wire: Nominal sectional area 1.42mm² (16 AWG)–0.5mm² (20 AWG)

Connector	GE Fanuc Part No.	Manufacturer
DC Power Supply	N/A	N/A
Servo Amplifier CX11-5	Part of Kit A06B-6093-K301	Nihon AMP (Housing: 175362-1; Contact: 1-175218-2)

K14—Motor Brake Power Cable (β2/3000, β6/2000, αC12/2000)

(β0.5/3000 brake wiring is include in power cable K4)

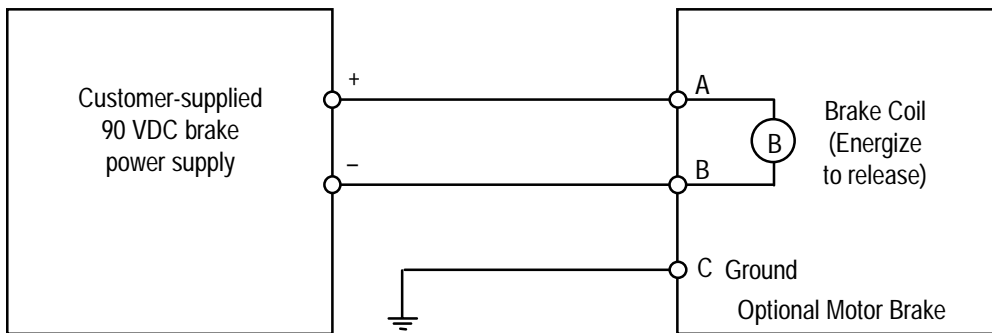

- Prefinished 14m Cable, Part number: 44C742238-004 (severe duty)
- Wire: 300V, 3-conductor, 20 AWG (0.5mm²), finstrand, 80 °C, polyurethane (PUR) jacket

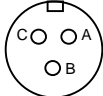
Connector	GE Fanuc Part No.	Manufacturer
Motor Brake	Customer-made cable: 44A730464-G26 GE Fanuc cable: 44A739012-G08	DDK CE Series (CE02-6A10SL-3CS) with Raychem Boot (222A-32-25142) 

15.4 β SERIES AMPLIFIER PROTECTION AND ALARM FUNCTIONS

The Servo Amplifier Unit can detect error conditions and provide alarm information.

The LEDs on the front of the amplifier provide a visual cue to the status of the system by indicating, for example, when the motor and amplifier are ready to function. The ALM LED is turned ON when an alarm condition is detected. When an alarm is detected, power is dropped and the motor is stopped by dynamic braking action. Alarm information is displayed as diagnostic data in the GE Fanuc controller. Table 45 details the alarm conditions the β Series Servo Amplifier System can detect.

Table 45. β Series Servo Amplifier Alarm System

Alarm Condition	Description
Over-voltage	Issued when the DC voltage in the main circuit power supply is abnormally high.
DC link under-voltage	Issued when the DC voltage in the main circuit power supply is abnormally low or when the circuit breaker has tripped.
Regenerative overheat	Issued when the average regenerative discharge energy is excessively high, such as when acceleration/deceleration is performed too frequently.
Overheat	Issued when the temperature inside the amplifier becomes so high that the thermostat trips.
Fan failure	Issued when the fan unit built into the amplifier fails.
Over-current	Issued when an abnormally high current is detected in the main circuit.

A

- Absolute Encoder Battery, 13, 70
- AC line filter, 82
- AC power, 32, 35, 82, 84
- Alarm Functions, 59, 105
- Alpha Servo System
 - Block Diagram, 5
 - Overview, 1
 - Package Options, 11
- Alpha Servo system specifications, 10
- Alpha SVU Series, 5
- Alpha SVU1 Amplifier Connections, 43
- Amplifier Control Power, 85
- Amplifier Package, Alpha Series, 9
- Amplifiers, 1
 - Alarm Functions, 24, 59, 77, 105
 - Alpha heat dissipation, 15
 - Beta heat dissipation, 72
 - Connector Kit, 88
 - Alpha Series, 44
 - Beta Series, 88
 - Environmental Requirements, 14, 71
 - Maintenance Clearances, 72
 - Models, 9, 67
- Axial Load, 24, 77

B

- Battery Packs, Encoder, 13
- Battery, Packs Encoder, 70
- Bearing, 24, 77
- Beta Servo System
 - Block Diagram, 63
 - Overview, 1
 - Package Options, 69
 - Specifications, 68
- Block diagram, 5, 63
- Brake, 12
 - Alpha Series motor, 8
 - Beta Series motor, 66
- Brake Power Supply, 8

C

- Cable Connections
 - Alpha Series, 45
- Cables, Alpha Series
 - K10-Emergency Stop/Power Enable Cable, 56
 - K11-Separate Regenerative Discharge Unit Fan Supply Cable, 57
 - K12-Motor Brake Power Connection, 57
 - K13-Cooling Fan Power Connection, 58
 - K1-Servo Command Signal Cable, 47
 - K2-Motor Encoder Feedback Cable, 49

- K3-Three-Phase Servo Power Cable, 50
- K4-Motor Power Cable (α 12/3000, α 22/2000), 50
- K4-Motor Power Cable (α 30/3000, α 40/2000), 52
- K4-Motor Power Cable (α 30/3000, α 40/2000), 51
- K5-Amplifier Stop Connection, 53
- K6-Amplifier Control Power Connection, 53
- K7-Separate Regenerative Discharge Unit Power Cable, 54
- K8-Separate Regenerative Discharge Unit Thermal Protection Cable, 54
- K9-Optional Absolute Encoder Battery Cable, 55
- Cables, Beta Series
 - K10-Emergency-Stop/Power Enable Cable, 103
 - K12-24 VDC Amplifier Power Cable, 103
 - K13-24 VDC Power Daisy Chain Cable, 104
 - K14-Motor Brake Power Cable, 104
 - K1-Servo Command Signal Cable, 91
 - K2-Motor Encoder Feedback Cable (β 0.5/3000), 93
 - K2-Motor Encoder Feedback Cable (β 2/3000, β 6/2000), 94
 - K3-Three-Phase Servo Power Cable, 96
 - K4-Motor AC Power Cable (β 2/3000, β 6/2000), 98
 - K4-Motor Power Cable (β 0.5/3000), 97
 - K4-Motor Power Cable (α C 12/2000), 99
 - K5-Emergency Stop Connection, 100
 - K7-Regenerative Discharge Cable, 101
 - K8-Regenerative Discharge Thermal Protection Cable, 101
 - K9-Absolute Encoder Battery Cable, 102
 - Motor Encoder Feedback Cable (α C12/2000), 95
- Cables, connection
 - Details, 47, 91
- Catalog Numbers
 - Alpha Series, 9
 - Beta Series, 67
- Circuit breaker, 34, 83
- Clearances
 - Amplifier, 15, 72
- Connection
 - Details, 47, 91
- Connectors
 - Alpha Series Motors, 44
 - Beta Series Motors, 88
- Contact rating, 34, 83
- Control Power, 35

D

- DC power, 85
- Dimensions
 - AC Line Filters, 33
 - Alpha Series amplifier Panel cutouts, 25
 - Alpha Series amplifiers, 25
 - Alpha Series Regenerative D.U., 40
 - Beta Series amplifier, 78
 - Discharge Resistor, 41

Motor, 65
Discharging regenerative energy, 36, 85
Dissipation
 Amplifier, 15, 72

E

Encoder
 Battery, 13, 70
Environmental requirements
 Alpha amplifiers, 14
 Alpha Series, 14
 Beta amplifiers, 71
 Beta Series, 71
 Motors, 14, 71

F

Feedback, 44

G

Ground fault interrupter
 Alpha Series, 31
 Beta Series, 81
Grounding
 Alpha Series, 29
 Beta Series, 79
Grounding Clamp, 30

H

Heat dissipation
 Alpha Series, 15
 Beta Series, 72
High Response Vector function, 7, 65

I

Installation Guidelines, 14, 71
International Standards, 1

L

Line Filter, 32, 82

M

Maintenance Clearances, 72
Motor Dimensions
 $\beta 0.5/3000$, 73
 $\alpha 12/3000$, 18
 $\beta 2/3000$, 74
 $\beta 2/3000$ w/brake, 76
 $\alpha 22/3000$, 18
 $\alpha 30/3000$, 18
 $\alpha 40/2000$, 21

$\beta 6/2000$, 74
 $\beta 6/2000$ w/brake, 76
 $\alpha 6/3000$, 16
 $\alpha C12/2000$, 74
 $\alpha C12/2000$ w/brake, 76
Motor Power, 44
Motors, 1, 12
 Beta Series, 65
 Brake, 8, 12, 66
 Environmental Requirements, 14, 71
 Speed-Torque Curves
 HRV function, 7, 65

N

Noise Protection
 Alpha Series, 29
 Beta Series, 79

O

Optional Connectors, 44
Options
 Alpha Series, 11
 Beta Series, 69
Overview, 1, 6, 64

P

Package Options, 11, 69
Part Numbers
 Alpha Series, 9
 Beta Series, 67
Power Line Protection, 32, 82
Power requirements
 AC power, 35, 84
 Alpha Series, 32
 Alpha Series Circuit Breakers, 34
 Alpha Series Discharging Regenerative Energy, 36
 Alpha Series Electromagnetic Contactor, 34
 Alpha Series Incoming AC Power, 32
 Beta Series, 82
 Beta Series AC Power, 82
 Beta Series Circuit Breakers, 83
 Beta Series Discharging Regenerative Energy, 85
 Beta Series Electromagnetic Contactor, 83
 Incoming DC Power, 85
Protection
 Alpha Series, 59
 Beta Series, 105
Pulse Width Modulated interface, 1

R

Radial Load, 24, 77
Regenerative Discharge Units
 Alpha Series, 36
 Beta Series, 85

Regenerative Energy, 36, 85
Regenerative Energy, Calculating for Alpha Series, 36
Regenerative Energy, Calculating for Beta Series, 86

S

Sealing Option, 12
Servo Motors, 1, 65
Servo package options, 11, 69
Shaft Loading
 Alpha Series, 24
 Beta Series, 77

Specifications
 Alpha Series, 10
 Beta Series, 68
Speed-Torque curves
 Alpha Series, 7
 Beta Series, 65
Standards, 1
Switch Settings, 28

T

Transformer, 32, 82