

YASKAWA AC Drive-A1000

Traverse Application

Custom Software Supplement

Software Number: VSA91019□

Drive Models: AU□A□□□□□□□

To properly use the product, read this manual thoroughly and retain for easy reference, inspection, and maintenance. Ensure the end user receives this manual.

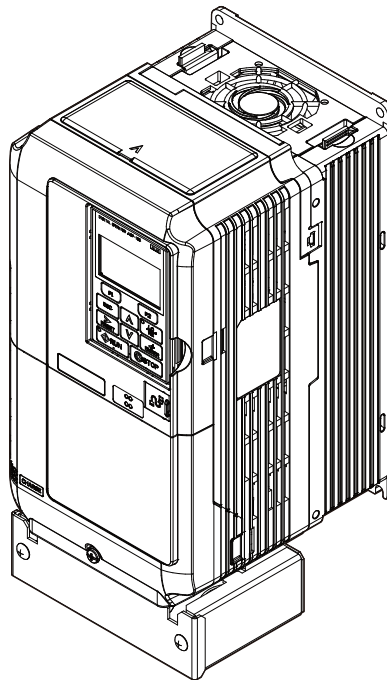

Table of Contents

- 1 PREFACE AND SAFETY5
- 2 PRODUCT OVERVIEW6
- 3 APPLICATION SELECTION7

Refer to the A1000 Technical Manual for content not described in this document.

Copyright © 2013 YASKAWA ELECTRIC CORPORATION

All rights reserved. No part of this publication may be reproduced, stored in a retrieval system, or transmitted, in any form or by any means, mechanical, electronic, photocopying, recording, or otherwise, without the prior written permission of Yaskawa. No patent liability is assumed with respect to the use of the information contained herein. Moreover, because Yaskawa is constantly striving to improve its high-quality products, the information contained in this manual is subject to change without notice. Every precaution has been taken in the preparation of this manual. Yaskawa assumes no responsibility for errors or omissions. Neither is any liability assumed for damages resulting from the use of the information contained in this publication.

This Page Intentionally Blank

1 Preface and Safety

Yaskawa manufactures products used as components in a wide variety of industrial systems and equipment. The selection and application of Yaskawa products remain the responsibility of the equipment manufacturer or end user. Yaskawa accepts no responsibility for the way its products are incorporated into the final system design. Under no circumstances should any Yaskawa product be incorporated into any product or design as the exclusive or sole safety control. Without exception, all controls should be designed to detect faults dynamically and fail safely under all circumstances. All systems or equipment designed to incorporate a product manufactured by Yaskawa must be supplied to the end user with appropriate warnings and instructions as to the safe use and operation of that part. Any warnings provided by Yaskawa must be promptly provided to the end user. Yaskawa offers an express warranty only as to the quality of its products in conforming to standards and specifications published in the Yaskawa manual. **NO OTHER WARRANTY, EXPRESS OR IMPLIED, IS OFFERED.** Yaskawa assumes no liability for any personal injury, property damage, losses, or claims arising from misapplication of its products

◆ Applicable Documentation

The following manuals are available for the A1000 Drive:

Custom Software Supplement

	Yaskawa AC Drive - Traverse Application A1000 Custom Software Supplement Manual No: TM.A1000SW.029
	Read this manual first. This supplement is an addendum to the A1000 Quick Start Guide and Technical Manual. It lists the effects of this custom software on the parameters in the drive and function descriptions in the manual. To obtain the supplement access this site: U.S: http://www.yaskawa.com

Yaskawa Drive

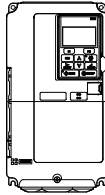
	Yaskawa AC Drive - A1000 Quick Start Guide	To obtain instruction manuals for Yaskawa products access these sites: U.S.: http://www.yaskawa.com Europe: http://www.yaskawa.eu.com Japan: http://www.e-mechatronics.com Other areas: contact a Yaskawa representative. For questions, contact the local Yaskawa sales office or the nearest Yaskawa representative.
	Yaskawa AC Drive - A1000 Technical Manual	

◆ Supplemental Safety Information

Read and understand this manual and the A1000 Quick Start Guide before installing, operating, or servicing this option unit. Install the drive according to the A1000 Quick Start Guide and local codes. Observe all cautions and warnings in this document and the standard drive technical manuals.

Refer to the A1000 Quick Start Guide and Technical Manual for safety information and to install and start-up the drive.

This document is a supplement to the standard drive technical manual. It describes the effects on the drive parameters and functions with the software installed.

- Custom software is provided to add functionality to a standard drive to enhance or enable use in a specific application.
- The software is loaded to the flash ROM area of the control board, and replaces the standard drive software.

◆ Obtaining Support

When seeking support for a drive with custom software, it is imperative to provide the unique part number shown on the drive nameplate. The software is flashed to the control board memory and the operation of parameters, functions, and monitors are different than the standard drive software, as described herein.

Refer to Yaskawa office locations listed on the back cover of this manual.

2 Product Overview

◆ About This Product

This custom software is designed specifically for use in Traverse applications.

◆ Applicable Models

This custom Traverse application software is available for the A1000 drive models listed in *Table 1*.

Table 1 Applicable Models

Voltage Class	Models	Software Version <1>
200 V Three-Phase	AU2A0004F□□ to 2A0211F□□, AU2A0250A□□ to 2A0415A□□	VSA91019□
400 V Three-Phase	AU4A0002F□□ to 4A0165F□□, AU4A0208A□□ to 4A0675A□□	VSA91019□
600 V Three-Phase	AU5A0003F□□ to 5A0099F□□, AU5A0125A□□ to 5A0242A□□	VSA91019□

<1> See “PRG” on the drive nameplate for the software version number.

3 Application Selection

◆ Traverse Anti-Phase

■ Overview

The Traverse Anti-Phase function controls the traverse arm of a winder in textile industry applications. This function generates a dithered disturbed waveform that is used as frequency reference for the traverse arm drive and also provides an anti-phase signal for output to a spindle slave drive for better winding.

■ Basic Concept

When the drive reaches the set frequency reference, the output frequency waveform is modulated in a triangle type pattern. This randomizes fiber overlap on the spindle, producing a tighter wrap and a higher quality wound package.

P1 parameters are used to set the attributes of a disturbed waveform, which is essentially a triangle wave with instantaneous jumps at the peak and trough. This triangle wave rides on top of the base frequency reference for the traverse drive.

The signal(s) output to control the slave spindle drive can be set to one of three new monitors:

- U7-02 - Absolute Slave Frequency
- U7-03 - Ripple Slave Frequency
- U7-04 - Slave Base Frequency

The Absolute and Ripple Slave Frequency monitors have an anti-phase component to them, outputting a disturbed waveform that is the inverse (anti-phase) of the master disturbed waveform. The anti-phase waveform ignores the jump portion of the master traverse disturbed waveform.

■ Limitations

- The following languages are supported: English, Japanese, Spanish, German, French, Italian, and Portuguese.
- Parameter L4-02, Speed Agree Detection Width, should be set to a small, nonzero value to avoid unintended jumps in the disturbed waveforms.
- When P1-04 and P1-05 are set to short slope times, set L4-02 to a value greater than 0.5 Hz to prevent inconsistent traverse operation.
- Step changes in frequency reference will result in unintended jumps in the disturbed waveforms. Disable the Traverse function using the 80h (Disturbed WF Off) digital input to prevent damage to the motor or connected equipment.
- The Traverse waveform can be configured to be smaller than the input resolution of the A1000 slave drive's frequency reference. Ensure that Master Frequency Reference \times P1-02 is significantly larger than (Slave Max Output Freq/2048) for proper control of the slave drive.

3 Application Selection

◆ Control Modes, Symbols, and Terms

The table below lists terms and symbols used in this section to indicate which parameters are available in which control modes.

	Description
All Modes	Parameter is available in all control modes.
V/f	Parameter is available when operating the drive with V/f Control.
V/f w PG	Parameter is available when operating the drive with V/f with PG Control.
OLV	Parameter is available when operating the drive with Open Loop Vector.
CLV	Parameter is available when operating the drive with Closed Loop Vector.
OLV/PM	Parameter is available when operating the drive with Open Loop Vector for PM monitors.
AOLV/PM	Parameter is available when operating the drive with Advanced Open Loop Vector for PM monitors.
CLV/PM	Parameter is available when operating the drive with Closed Loop Vector for PM monitors.

◆ Related Parameters and Functions

The following parameters are used to set up the drive for operation with the software. Available parameter settings are listed based upon which drive control modes are active, as listed in the Control Mode Access Level column in the following tables.

Confirm proper setting of the parameters beginning with [Table 2](#).

Table 2 Modified Parameters

No. (Addr. Hex)	Parameter Name Digital Operator Display	Description	Values	Change during Run	Control Mode Access Level
A1-00 (100h)	Language Selection Select Language	0: English 1: Japanese 2: German 3: French 4: Italian 5: Spanish 6: Portuguese	Default: 0 Range: 0 to 6	No	All Modes

Table 3 Additional Parameters

No. (Addr. Hex)	Parameter Name Digital Operator Display	Description	Values	Change during Run	Control Mode Access Level
P1-01 (600h)	Disturbed Waveform Selection Disturb WF Sel	Enables and disables the traverse disturbed waveform function. 0: Disabled 1: Enabled	Default: 0 Range: 0 to 1	Yes	V/f OLV OLV/PM
P1-02 (601h)	Disturbed Waveform Amplitude Disturb WF Amp	Sets the amplitude of the disturbed waveform as a percentage of the commanded frequency reference. Note: Setting this parameter to 0.0 disables the Transverse function.	Default: 0.0 Range: 0.0 to 20.0 %	Yes	V/f OLV OLV/PM
P1-03 (602h)	Disturbed Waveform Jump Disturb WF Jmp	Adds a notch or jump below the peak amplitude of the disturbed waveform when set to a non-zero value. Set as a percentage of the Disturbed Waveform Amplitude (P1-02).	Default: 0.0 Range: 0 to 50.0%	Yes	V/f OLV OLV/PM
P1-04 (603h)	Negative Slope Time Neg Slope Time	Sets the time for the disturbed waveform to decelerate from the maximum value (reference + P1 02) to the minimum value (reference - P1-02). Note: Setting this parameter to 0.0 seconds disables the Transverse function.	Default: 0.0 Range: 0.0 to 120.0 s	Yes	V/f OLV OLV/PM
P1-05 (604h)	Positive Slope Time Pos Slope Time	Sets the time for the disturbed waveform to accelerate from the minimum value (reference - P1 02) to the maximum value (reference + P1-02). Note: Setting this parameter to 0.0 seconds disables the Transverse function.	Default: 0.0 Range: 0.0 to 120.0 s	Yes	V/f OLV OLV/PM
P1-06 (605h)	Slave Scan Offset Slv Scan Offset	Monitor shift (U7-02, U7-03, and U7-04) in ms to compensate for systematic delays.	Default: 0 ms Range: -24 ~ 24 ms	Yes	V/f OLV OLV/PM

Table 4 Group Text

Function Group	Group Name Digital Operator Display
P	Traverse Group Traverse

3 Application Selection

Table 5 Function Text

Function Group	Function Name Digital Operator Display
P1	Disturbed Waveform Adjustment Disturb WF Adj

Table 6 Monitor Function Text

Function Group	Monitor Name Digital Operator Display
U7	Traverse Monitors Traverse

Table 7 Monitors

No. (Addr. Hex)	Monitor Name Digital Operator Display	Description	Analog Output Scaling	Unit	Control Mode Access Level
U7-02 (661h)	Absolute Slave Frequency Slv Abs Freq	Base frequency reference summed with the anti-phase dither.	10V: Maximum Frequency (E1-04)	0.01 Hz	<input type="button" value="V/f"/> <input type="button" value="OLV"/> <input type="button" value="OLV/PM"/>
U7-03 (662h)	Ripple Slave Frequency Slv Ripple Freq	Anti-phase dither alone.	10V: Maximum Frequency (E1-04)	0.01 Hz	<input type="button" value="V/f"/> <input type="button" value="OLV"/> <input type="button" value="OLV/PM"/>
U7-04 (663h)	Base Slave Frequency Slv Base Freq	Base frequency reference (before disturbed waveform is applied).	10V: Maximum Frequency (E1-04)	0.01 Hz	<input type="button" value="V/f"/> <input type="button" value="OLV"/> <input type="button" value="OLV/PM"/>

Table 8 Multi-function Input Settings (H1-□□)

Setting	Description	Control Mode Access Level
80h	Disturbed WF Off Open: Disturbed waveform enabled Closed: Disturbed waveform disabled	<input type="button" value="V/f"/> <input type="button" value="OLV"/> <input type="button" value="OLV/PM"/>

Table 9 Multi-function Output Settings (H2-□□)

Setting	Description	Control Mode Access Level
40h	Disturb UP Sts Open: The disturbed waveform frequency is decreasing Closed: The disturbed waveform frequency is increasing	<input type="button" value="V/f"/> <input type="button" value="OLV"/> <input type="button" value="OLV/PM"/>
41h	During Disturb Open: Disturbed waveform disabled Closed: Disturbed waveform being generated	<input type="button" value="V/f"/> <input type="button" value="OLV"/> <input type="button" value="OLV/PM"/>

■ Function Description

Machine Parameter Selection

The disturbed waveform begins once the drive reaches Speed Agree. The disturbed waveform rides on top of the base frequency reference for the traverse drive. The output will be the frequency reference waveform summed with the disturbed waveform if the frequency reference of the master drive is adjusted while the disturbed waveform is active.

The dithering is a triangle waveform with amplitude and slope set by P1-02, P1-04, and P1-05 parameters. The traverse drive also has a jump in the dithering wave form which is set by parameter P1-03.

The anti-phase output signal is the disturbed portion of the traverse frequency reference signal inverted. Only the triangle portion of the disturbed waveform is used for the anti-phase. The jump is ignored.

The Traverse application software has three monitors:

- Base Slave Frequency (U7-04)
U7-04, Base Slave Frequency, outputs the frequency reference of the master (traverse) before the disturbed waveform is applied.
- Ripple Slave Frequency (U7-03)
U7-03, Ripple Slave Frequency, outputs the anti-phase of the disturbed portion of the waveform.
- Absolute Slave Frequency (U7-02)
U7-02, Absolute Slave Frequency, outputs the anti-phase of the disturbed portion of the waveform summed with U7-04.

To compensate for system delays, U7-02, U7-03, and U7-04 monitors can be set to lead or lag the traverse control output by up to 24 scans (24 ms), set by P1-06.

All three monitors can be set to analog outputs. U7-02 or U7-03 would generally be used as an analog output going to the slave (spindle) for its frequency reference. U7-02 provides the slave a complete reference signal. U7-03 is used as a dither reference if the slave is to use its own base frequency reference as shown in *Figure 1*.

3 Application Selection

■ Application Example

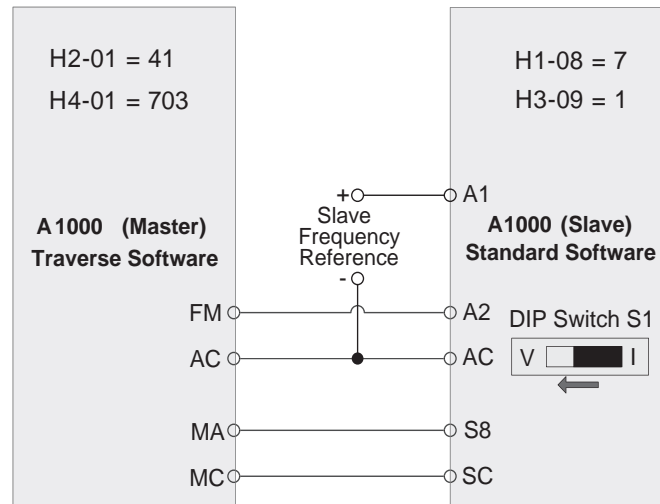

Figure 1 Software and Hardware Configuration for A1000 Traverse

Master Parameter Changes

- H2-01 = 41h: Provide during disturb status output to slave.
- H4-01 = 703: Provide disturbed frequency ripple to slave.
- H4-07 = 1: Provide a bipolar analog output signal.
- P1-01 = 1: Enable Traverse functionality.
- P1-02 ~ P1-05 = application requirements: Define the characteristics of the disturbed frequency.
- P1-06 = application requirement: Define scan offset to account for system delays.

Slave Parameter Changes

- C1-03 = 0.0 sec: Set acceleration time 2 to 0.0 seconds.
- C1-04 = 0.0 sec: Set deceleration time 2 to 0.0 seconds.
- H1-08 = 7: Switch between accel/decel time 1/2 based on During Disturb output.
- P1-01 = 1: Enable Traverse functionality.
- DIP Switch S1 = V: Enable voltage input to A2.
- H3-09 = 1: Set A2 to a -10V to +10V bipolar input.

■ Implementation

Situation 1: Standard Operation

When programmed with the settings as shown in [Table 10](#), the Traverse software produces output waveforms similar to the ones in [Figure 2](#). Using these settings and a reference frequency of 45 Hz, the master drive operates based on the triangle waveform with 9 Hz (peak-peak) amplitude. Because the waveform is centered on the 45 Hz reference frequency, the master waveform oscillates between 36 and 54 Hz while in Traverse mode.

Table 10 Sample Operating Parameters

Parameter	Name	Setting
P1-01	Disturbed Waveform Selection	1
P1-02	Disturbed Waveform Amplitude	20.0%
P1-03	Disturbed Waveform Jump	50.0%
P1-04	Negative Slope Time	5.0 s
P1-05	Positive Slope Time	4.0 s
P1-06	Slave Scan Offset	0 ms

U7-02, Slave Absolute Frequency, (available as an output to the slave by setting parameter H4-01 to 702), has the same amplitude of 9 Hz (calculated by $P1-02 \times \text{Reference Frequency}$). U7-02 is anti-phase to the master waveform and is centered around U7-04, the Slave Base Frequency. Since the Slave Base Frequency is 45 Hz, U7-02 varies from 36 to 54 Hz while in Traverse mode. Before entering Traverse mode, the Slave Absolute Frequency will rest at 48 Hz, as represented by the equation in [Figure 2](#).

U7-03, Slave Ripple Frequency, is the same as the U7-02 waveform without the Slave Base Frequency component. Slave Ripple Frequency U7-03 is a bipolar waveform centered at 0 Hz. The output varies from 21 to 39 Hz during operation. The Slave Ripple Frequency will rest at 3 Hz before entering Traverse mode as represented by the equation in [Figure 2](#).

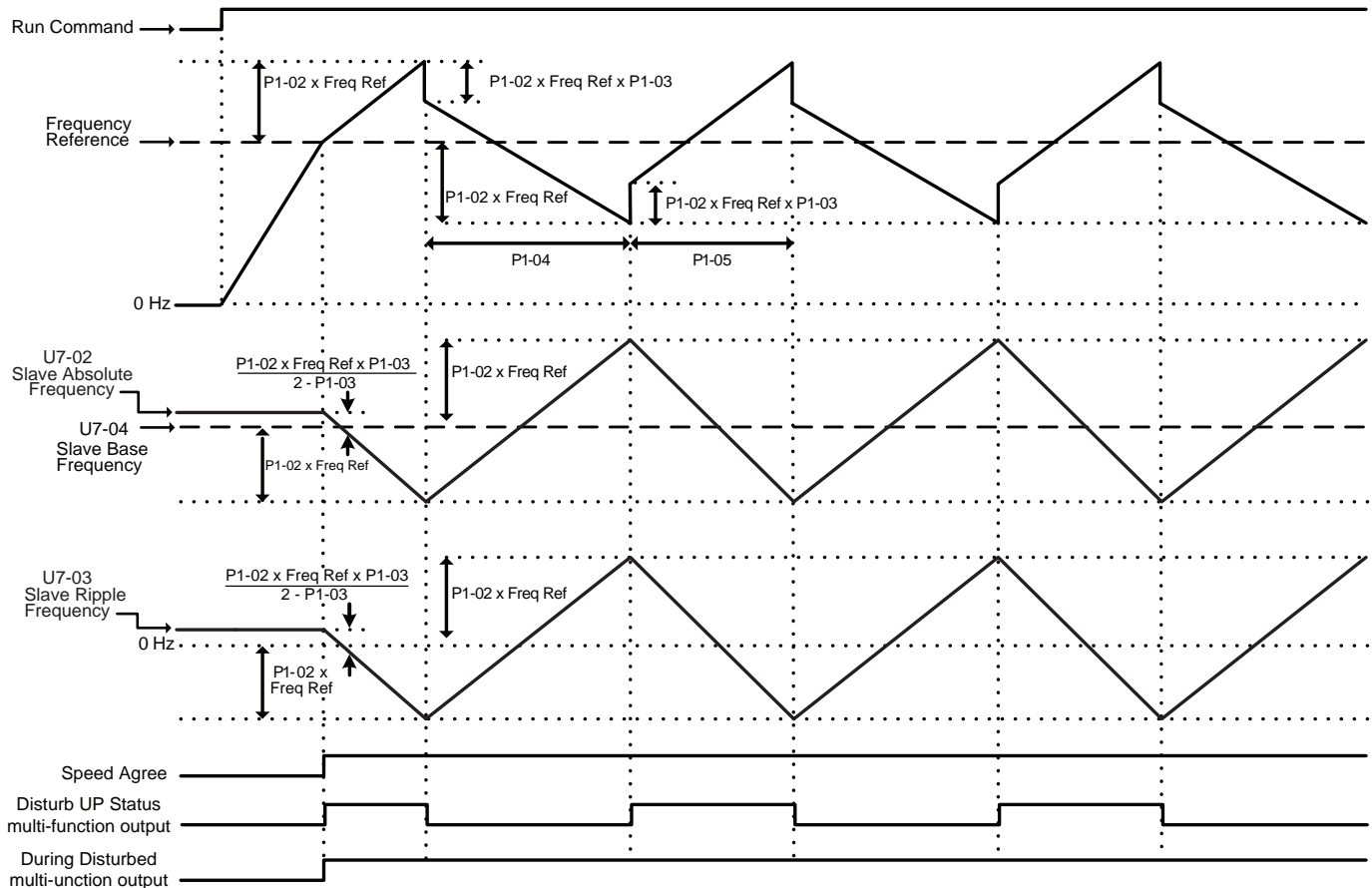

Figure 2 Master and Slave Output Diagram: Standard Operation

3 Application Selection

Situation 2: Traverse Operation Exceeds Maximum Output Frequency

Using the same parameter settings in [Table 10](#) and a reference frequency of 52 Hz, the Traverse software will produce output waveforms similar to the ones in [Figure 3](#). The Traverse software, with an amplitude of 10.4 Hz, will produce a triangle output that varies from 41.6 to 62.4 Hz. Setting the drive parameter E1-04 to 60.0 Hz caps the triangle waveform when the traverse frequency exceeds the Maximum Output Frequency of 60 Hz.

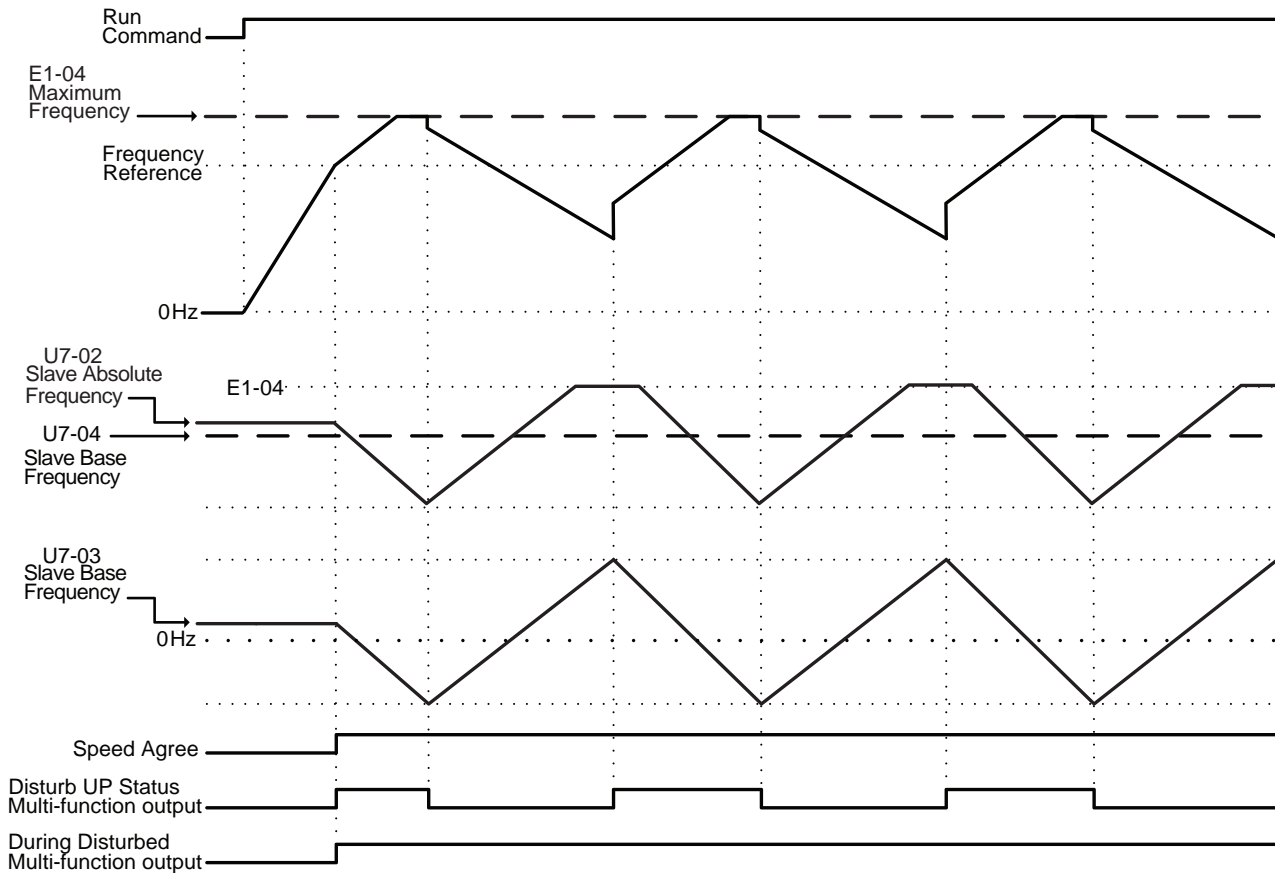

Figure 3 Traverse Mode Operation Outside of Max Output Frequency Parameter E1-04 / E3-04

Situation 3: Changing Reference Frequency

Using the parameter settings found in [Table 10](#) and a reference frequency that changes from 20 Hz to 30 Hz, the Traverse software will produce output waveforms similar to those in [Figure 4](#). Using the 20 Hz frequency reference, the master drive oscillates between 16 and 24 Hz. When the reference frequency increases to 30 Hz, the drive exits Traverse mode and accelerates using the default acceleration time set in parameter C1-01. When the drive reaches the new frequency reference, it re-enters Traverse mode and the master drive oscillates between 24 and 36 Hz.

Initially, U7-02, Slave Absolute Frequency, rests at 21.33 Hz. When the drive enters Traverse mode, U7-02 oscillates between 16 and 24 Hz. When the reference frequency changes, the drive exits Traverse mode and the Slave Absolute Frequency rises to 32 Hz until the drive re-enters Traverse mode. Once resuming traverse mode, the new waveform oscillates between 24 and 36 Hz.

U7-03, Slave Ripple Frequency, operates similar to U7-02, except that its waveform remains centered at 0 Hz.

Step changes in frequency reference will result in unintended jumps in the disturbed waveforms. Disable the Transverse function using the 80h, (Disturbed WF Off), to prevent damage to the motor or connected equipment before making large changes in the frequency reference.

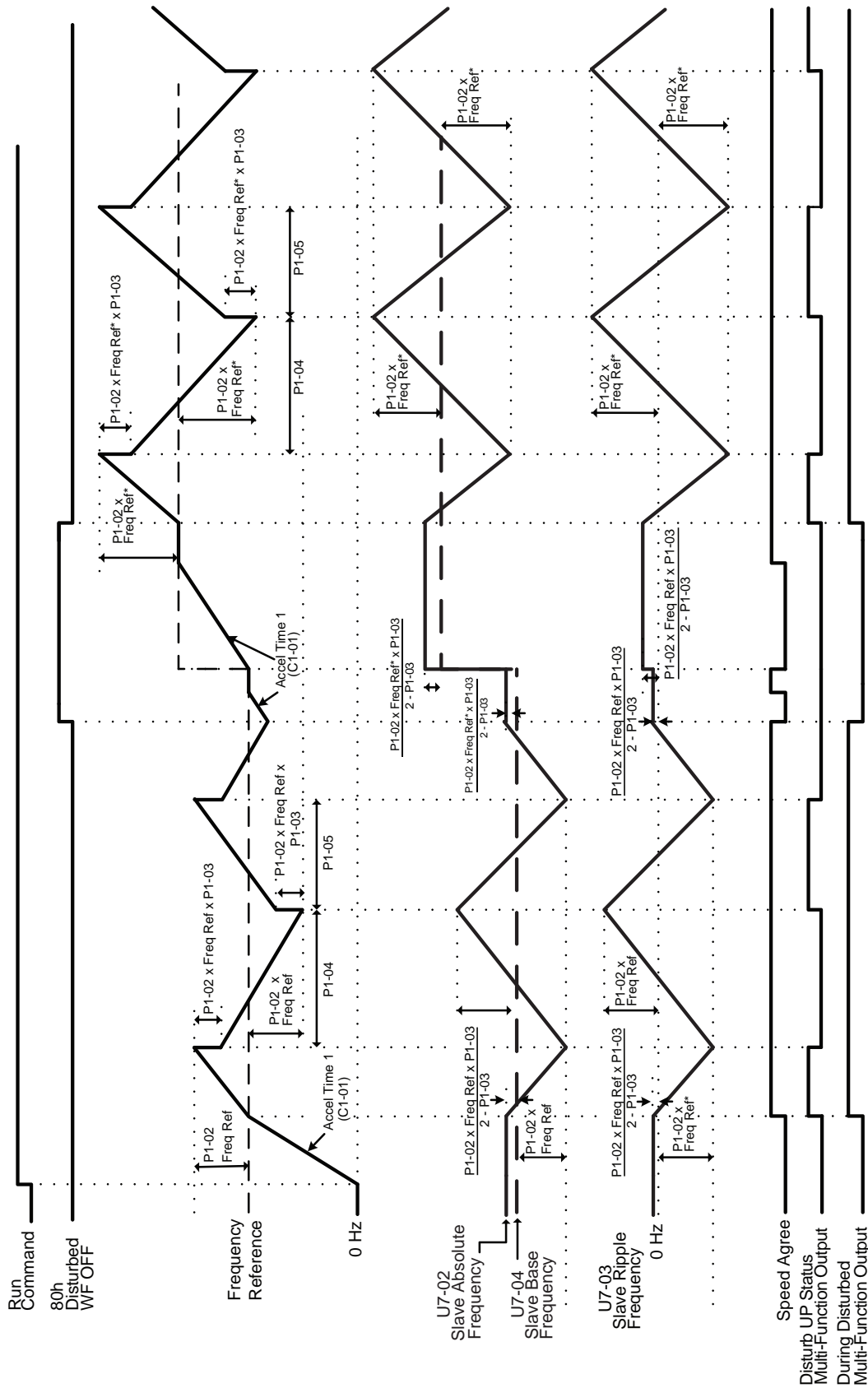



Figure 4 Traverse Mode Operation with Changing Frequency Reference

3 Application Selection

◆ Revision History

The revision dates and the numbers of the revised manuals appear on the bottom of the back cover.

MANUAL NO. TM.A1000SW.029

Published in U.S.A. April 2013 10-4 

└─ Date of publication

└─ Date of original publication

└─ Revision number

Date of Publication	Revision Number	Software Number	Revised Content
April 2013	-	VSA910190	First release

YASKAWA AC Drive-A1000

Traverse Application

Custom Software Supplement

YASKAWA AMERICA, INC.

2121 Norman Drive South, Waukegan, IL 60085, U.S.A.
Phone: (800) YASKAWA (927-5292) or 1-847-887-7000 Fax: 1-847-887-7310
<http://www.yaskawa.com>

DRIVE CENTER (INVERTER PLANT)

2-13-1, Nishimiyaichi, Yukuhashi, Fukuoka, 824-8511, Japan
Phone: 81-930-25-3844 Fax: 81-930-25-4369
<http://www.yaskawa.co.jp>

YASKAWA ELECTRIC CORPORATION

New Pier Takeshiba South Tower, 1-16-1, Kaigan, Minatoku, Tokyo, 105-6891, Japan
Phone: 81-3-5402-4502 Fax: 81-3-5402-4580
<http://www.yaskawa.co.jp>

YASKAWA ELÉTRICO DO BRASIL LTDA.

Avenda Fagundes Filho, 620 Bairro Saude, São Paulo, SP04304-000, Brasil
Phone: 55-11-3585-1100 Fax: 55-11-5581-8795
<http://www.yaskawa.com.br>

YASKAWA EUROPE GmbH

Hauptstrasse 185, 65760 Eschborn, Germany
Phone: 49-6196-569-300 Fax: 49-6196-569-398
<http://www.yaskawa.eu.com>

YASKAWA ELECTRIC UK LTD.

1 Hunt Hill Orchardton Woods, Cumbernauld, G68 9LF, United Kingdom
Phone: 44-1236-735000 Fax: 44-1236-458182
<http://www.yaskawa.co.uk>

YASKAWA ELECTRIC KOREA CORPORATION

7F, Doore Bldg. 24, Yeoido-dong, Yeongdungpo-gu, Seoul, 150-877, Korea
Phone: 82-2-784-7844 Fax: 82-2-784-8495
<http://www.yaskawa.co.kr>

YASKAWA ELECTRIC (SINGAPORE) PTE. LTD.

151 Lorong Chuan, #04-01, New Tech Park, 556741, Singapore
Phone: 65-6282-3003 Fax: 65-6289-3003
<http://www.yaskawa.com.sg>

YASKAWA ELECTRIC (SHANGHAI) CO., LTD.

No. 18 Xizang Zhong Road, 17F, Harbour Ring Plaza, Shanghai, 200001, China
Phone: 86-21-5385-2200 Fax: 86-21-5385-3299
<http://www.yaskawa.com.cn>

YASKAWA ELECTRIC (SHANGHAI) CO., LTD. BEIJING OFFICE

Room 1011, Tower W3 Oriental Plaza, No. 1 East Chang An Ave.,
Dong Cheng District, Beijing, 100738, China
Phone: 86-10-8518-4086 Fax: 86-10-8518-4082

YASKAWA ELECTRIC TAIWAN CORPORATION

9F, 16, Nanking E. Rd., Sec. 3, Taipei, 104, Taiwan
Phone: 886-2-2502-5003 Fax: 886-2-2505-1280



YASKAWA AMERICA, INC.

In the event that the end user of this product is to be the military and said product is to be employed in any weapons systems or the manufacture thereof, the export will fall under the relevant regulations as stipulated in the Foreign Exchange and Foreign Trade Regulations. Therefore, be sure to follow all procedures and submit all relevant documentation according to any and all rules, regulations and laws that may apply.

Specifications are subject to change without notice for ongoing product modifications and improvements.

© 2013 YASKAWA AMERICA, INC. All rights reserved.



TM.A1000SW.029

MANUAL NO. TM.A1000SW.029

Published in U.S.A. April 2013 04-13